

First edition
2009-05-15

**Materials for the production of primary
aluminium — Dense refractory bricks —
Determination of cryolite resistance**

*Matériaux pour la production de l'aluminium de première fusion —
Briques réfractaires denses — Détermination de la résistance de la
cryolite*



Reference number
ISO 20292:2009(E)

© ISO 2009

PDF disclaimer

This PDF file may contain embedded typefaces. In accordance with Adobe's licensing policy, this file may be printed or viewed but shall not be edited unless the typefaces which are embedded are licensed to and installed on the computer performing the editing. In downloading this file, parties accept therein the responsibility of not infringing Adobe's licensing policy. The ISO Central Secretariat accepts no liability in this area.

Adobe is a trademark of Adobe Systems Incorporated.

Details of the software products used to create this PDF file can be found in the General Info relative to the file; the PDF-creation parameters were optimized for printing. Every care has been taken to ensure that the file is suitable for use by ISO member bodies. In the unlikely event that a problem relating to it is found, please inform the Central Secretariat at the address given below.



COPYRIGHT PROTECTED DOCUMENT

© ISO 2009

All rights reserved. Unless otherwise specified, no part of this publication may be reproduced or utilized in any form or by any means, electronic or mechanical, including photocopying and microfilm, without permission in writing from either ISO at the address below or ISO's member body in the country of the requester.

ISO copyright office
Case postale 56 • CH-1211 Geneva 20
Tel. + 41 22 749 01 11
Fax + 41 22 749 09 47
E-mail copyright@iso.org
Web www.iso.org

Published in Switzerland

Contents

Page

Foreword	iv
1 Scope	1
2 Principle.....	1
3 Sampling.....	1
4 Reagents.....	1
5 Apparatus	1
6 Procedure	3
7 Precision statement	5
8 Test report.....	6
Bibliography.....	7

Foreword

ISO (the International Organization for Standardization) is a worldwide federation of national standards bodies (ISO member bodies). The work of preparing International Standards is normally carried out through ISO technical committees. Each member body interested in a subject for which a technical committee has been established has the right to be represented on that committee. International organizations, governmental and non-governmental, in liaison with ISO, also take part in the work. ISO collaborates closely with the International Electrotechnical Commission (IEC) on all matters of electrotechnical standardization.

International Standards are drafted in accordance with the rules given in the ISO/IEC Directives, Part 2.

The main task of technical committees is to prepare International Standards. Draft International Standards adopted by the technical committees are circulated to the member bodies for voting. Publication as an International Standard requires approval by at least 75 % of the member bodies casting a vote.

Attention is drawn to the possibility that some of the elements of this document may be the subject of patent rights. ISO shall not be held responsible for identifying any or all such patent rights.

ISO 20292 was prepared by Technical Committee ISO/TC 226, *Materials for the production of primary aluminium*.

Materials for the production of primary aluminium — Dense refractory bricks — Determination of cryolite resistance

1 Scope

This International Standard covers materials for the production of primary aluminium.

This International Standard specifies a method for the determination of the resistance of dense refractory bricks to cryolite melt with excess sodium fluoride.

2 Principle

A mixture of fine powders ($< 100 \mu\text{m}$) of cryolite and sodium fluoride are allowed to react at $950 \text{ }^\circ\text{C}$ in a furnace for 24 h in air, on a crucible-shaped test piece made of the dense refractory brick material to be tested.

Reacted and/or infiltrated areas of brick material are calculated. Together with the calculation, a visual description of the reaction extent is recommended and photographs should also be used to illustrate the attack.

3 Sampling

Take a number of different bricks from within the batch to be tested. Take a minimum of two sample bricks to prepare test pieces. The test pieces are taken from different bricks.

4 Reagents

4.1 Cryolite (Na_3AlF_6) powder, with a minimum purity of 97 % mass fraction and a particle size $< 100 \mu\text{m}$.

4.2 Sodium fluoride (NaF) powder, with a minimum purity of 99 % mass fraction and a particle size $< 100 \mu\text{m}$.

IMPORTANT — The electrolyte used in aluminium electrolysis will penetrate through the carbon block materials and then into the refractory. It is essential that this electrolyte penetration be stopped by reaction with the refractory. It is hence important to test the different refractory materials for resistance towards penetration. This test correlates well with penetration in industrial cells.

5 Apparatus

5.1 Diamond saw, with water cooling.

5.2 Core drilling apparatus, standard drilling machine with water cooling.

5.3 Three drill pieces, to be mounted on the drilling machine:

- a) a 50 mm diamond core drill that gives a (57 ± 1) mm hole;
- b) a 30 mm core drill;
- c) a 48 mm to 50 mm steel disk mounted on a stem, where pieces from a diamond core drill, that are 3 mm high with the same radius of curvature as the disk, are glued on underneath (see Figure 1).

5.4 Furnace, capable of heating the test crucibles as required to (950 ± 5) °C.

5.5 Thermocouples, at least three, capable of measuring temperatures of 950 °C.

5.6 Drying cabinets, capable of drying the test crucibles as required at (110 ± 5) °C.

5.7 Photocopy machine.

5.8 Photocopy paper.

5.9 Balance, accurate to 0,01 g.

SAFETY PRECAUTIONS — During exposure, fluoride gas will be generated. The corrosive gasses will react and accumulate in the refractory lining in the furnace. The laboratory performing this test should preferably have a special (gastight) furnace for this test method. There is also a risk of the fluoride melt penetrating through the crucible and into the bottom lining of the furnace. The furnace should be placed in a well-ventilated room or be equipped with a spot extraction fan.

Dimensions in millimetres

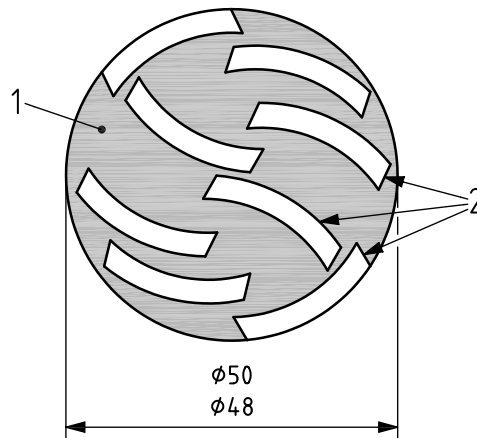

Key

- 1 steel base
- 2 pieces from a diamond core drill

Figure 1 — Underside of the steel disk for bottom smoothing

6 Procedure

6.1 Preparation of test crucibles

Cut the sample bricks with the watercooled diamond saw (5.1) into test pieces with sides of length approximately 110 mm and height approximately 65 mm. Produce test crucibles with a borehole of diameter (57 ± 1) mm and a depth of (40 ± 1) mm in the middle of each test piece (see Figure 2).

The borehole is produced using the core drilling apparatus (5.2) in the following way. Use the 30 mm core drill (see 5.3) to make a hole in the middle of the test piece. Do not drill the hole all the way down to 40 mm. Pry the core loose. Then, apply the 50 mm core drill outside the first hole and remove the inside material. The disk with the mounted diamond pieces is used to smooth the bottom and obtain the proper depth (see Figure 2). Use water cooling during all operations.

Dimensions in millimetres

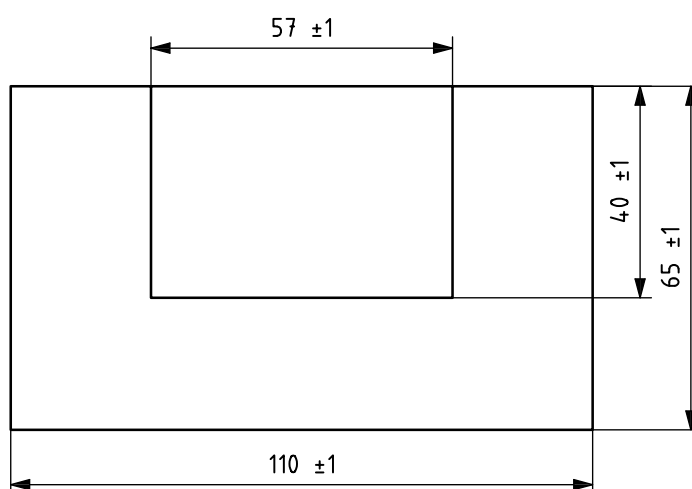

Figure 2 — Dimensions of test piece

Cut the sample bricks with the diamond saw (5.1) into lids of suitable size and 10 mm thick to cover the borehole.

Dry the test crucibles for at least 8 h at (110 ± 5) °C before the experiment.

6.2 Verification of suitability of furnace

Verify the suitability of the furnace (5.4) to ensure that the test piece experiences a uniform temperature at (950 ± 5) °C as follows. Define and mark a sample location in the furnace. Place a test piece in the sample location. Place at least three thermocouples in the furnace, two positioned at opposite sides and one on the top of the test piece. Read the furnace temperatures from the thermocouples. At steady state (soaking), the temperature difference between the three thermocouples shall not exceed 8 °C. To ensure completely identical test conditions, only one test piece is exposed at a time.

6.3 Test procedure

Prepare a powder mixture consisting of 60 % mass fraction cryolite (4.1) and 40 % mass fraction sodium fluoride (4.2). Stir the mixture thoroughly with a glass rod for 1 min and place 150 g of it in the borehole. Cover with the 10 mm lid (see third paragraph of 6.1) of the same material as the testing material. The lid should rest on the brick surface.

Place the test crucibles in the furnace at the marked sample location (see 6.2).

Raise the temperature of the furnace at a heating rate of 300 °C/h up to 900 °C. Then, continue heating from 900 °C to 950 °C at a heating rate of 50 °C/h to prevent the furnace temperature overshooting. Keep the sample at (950 ± 5) °C for 24 h. The test is carried out in air. The fluoride mixture will be liquid at 950 °C.

After completion of the 24 h stage at 950 °C, switch off the furnace and allow it to cool.

Remove the cooled crucible and saw through it diagonally (see Figure 3) in such a way that one cut plane includes the axis of the drilled hole. To ease the subsequent calculation of the reacted and infiltrated area, it is recommended to draw a pencil line along the diagonal of the sample. The diamond-saw cut should be made along this line in such a way that the original dimension of the borehole is not changed during the cutting and remains as $57 \text{ mm} \pm 1 \text{ mm}$ (see Figure 3).

Examine this part of the test piece.

Dimensions in millimetres

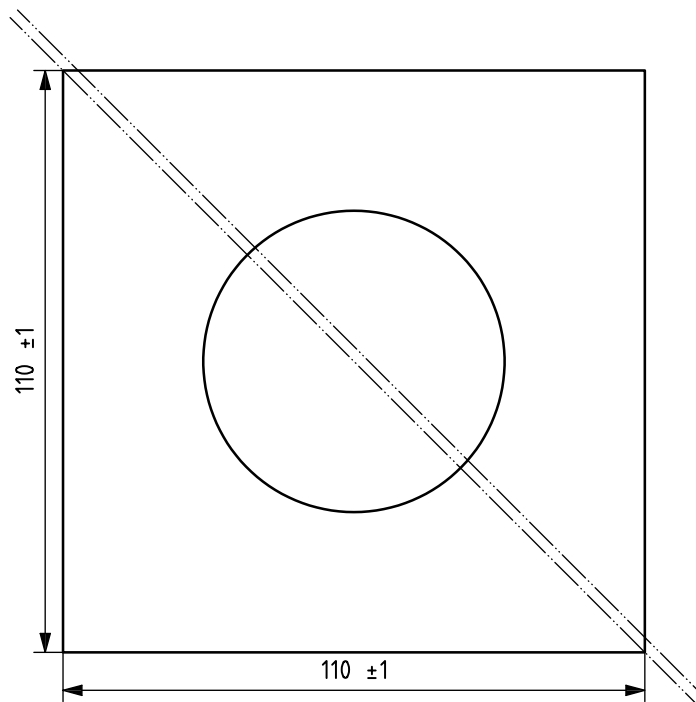

Figure 3 — Cutting of test piece

6.4 Evaluation

6.4.1 Calculation of reacted area

Place the cut face of the test crucible in the photocopier (5.7) on a transparent plastic foil (to protect the machine). Take a paper photocopy of the cut face.

From the paper photocopy image, cut out the area corresponding to the dissolved area and weigh the paper piece (m_1) to the nearest 0,01 g (see Figure 4). From the same paper, cut out 100 cm^2 and weigh to find the mass equivalent to 1 cm^2 (m_2).

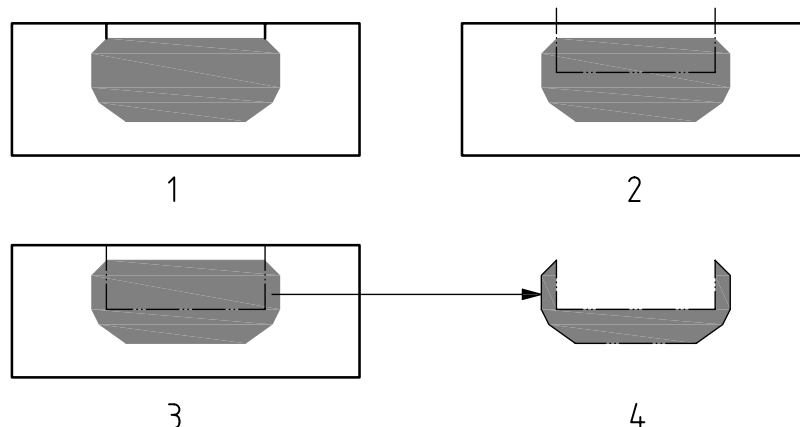

Key

- 1 photocopy of tested brick after cutting
- 2 marking of original borehole dimensions
- 3 extracting the area for cryolite resistance determination (by cutting the paper with scissors)
- 4 reacted and infiltrated area used to determine cryolite resistance of tested brick

Figure 4 — Procedure to determine reacted area

Calculate the dissolved area, A , in square centimetres (cm²), from the following equation:

$$A = \frac{m_1}{m_2}$$

where

A is the reacted area that has been dissolved, in square centimetres;

m_1 is the mass, in grams, of the paper representing the dissolved area;

m_2 is the mass per square centimetre of the photocopy paper.

Image-analysis equipment may also be used.

In some cases, the electrolyte runs through the sample. This should only be given as a qualitative result.

6.4.2 Infiltrated area

Usually the electrolyte reacts with the refractory. In some cases, an additional infiltration without reaction is observed. A remark should be made if this is the case and the infiltrated area estimated.

The same method as described in 6.4.1 can be used for calculating the infiltrated area. (Infiltration of a fluoride melt in refractory bricks is usually diffuse and not clearly defined, which makes the calculations less accurate.)

7 Precision statement

7.1 Repeatability

The results obtained with the same method on identical test pieces in the same test or measuring facility by the same operator using the same equipment within short intervals of time shall, in not less than 95 % of cases, differ by less than 0,7 cm².

7.2 Reproducibility

The results obtained with the same method on identical test pieces in different test or measurement facilities with different operators using different equipment shall, in not less than 95 % of cases, differ by less than 1,5 cm².

The precision is independent of the measured level of cryolite resistance in the range 2,0 cm² to 6,0 cm².

8 Test report

The test report shall include the following information:

- a) a reference to this International Standard;
- b) the place and date of testing;
- c) details necessary for the identification of the material tested (e.g. client, manufacturer, type, dimensions, etc.);
- d) number of crucible-shaped test pieces, dimensions of crucible and borehole;
- e) origin of the cryolite and sodium fluoride;
- f) type of furnace used for the experiment, dimensions of the furnace chamber;
- g) number of crucibles tested;
- h) test temperature;
- i) description of the crucible halves after the test, i.e. the appearance of the dissolved area and of the possibly infiltrated area;
- j) photocopies of the cut face;
- k) calculated areas of dissolved and possibly infiltrated areas, in square centimetres, to the nearest 0,1 cm.

Bibliography

- [1] SILJAN, OLE-JACOB; SCHONING, CHRISTIAN and GRANDE, TOR: *State-of-the-Art Alumino-Silicate Refractories for Al Electrolysis Cell*, JOM, Vol. 54, No. 5, May 2002, pp. 46-54; 63.

ICS 71.060.50; 71.100.10

Price based on 7 pages