**Resistance welding — Locking tapers
for electrode holders and electrode
caps**

*Soudage par résistance — Cônes de serrage pour porte-électrodes et
pointes d'électrodes*



COPYRIGHT PROTECTED DOCUMENT

© ISO 2016, Published in Switzerland

All rights reserved. Unless otherwise specified, no part of this publication may be reproduced or utilized otherwise in any form or by any means, electronic or mechanical, including photocopying, or posting on the internet or an intranet, without prior written permission. Permission can be requested from either ISO at the address below or ISO's member body in the country of the requester.

ISO copyright office
Ch. de Blandonnet 8 • CP 401
CH-1214 Vernier, Geneva, Switzerland
Tel. +41 22 749 01 11
Fax +41 22 749 09 47
copyright@iso.org
www.iso.org

Contents

Page

Foreword	iv
1 Scope	1
2 Normative references	1
3 Terms and definitions	1
4 Dimensions and tolerances	2
4.1 General	2
4.2 Electrode holders	2
4.3 Electrode caps	2
5 Designation	3
5.1 Electrode holders	3
5.2 Electrode caps	3
6 Material	3
7 Marking	3
Bibliography	4

Foreword

ISO (the International Organization for Standardization) is a worldwide federation of national standards bodies (ISO member bodies). The work of preparing International Standards is normally carried out through ISO technical committees. Each member body interested in a subject for which a technical committee has been established has the right to be represented on that committee. International organizations, governmental and non-governmental, in liaison with ISO, also take part in the work. ISO collaborates closely with the International Electrotechnical Commission (IEC) on all matters of electrotechnical standardization.

The procedures used to develop this document and those intended for its further maintenance are described in the ISO/IEC Directives, Part 1. In particular the different approval criteria needed for the different types of ISO documents should be noted. This document was drafted in accordance with the editorial rules of the ISO/IEC Directives, Part 2 (see www.iso.org/directives).

Attention is drawn to the possibility that some of the elements of this document may be the subject of patent rights. ISO shall not be held responsible for identifying any or all such patent rights. Details of any patent rights identified during the development of the document will be in the Introduction and/or on the ISO list of patent declarations received (see www.iso.org/patents).

Any trade name used in this document is information given for the convenience of users and does not constitute an endorsement.

For an explanation on the meaning of ISO specific terms and expressions related to conformity assessment, as well as information about ISO's adherence to the World Trade Organization (WTO) principles in the Technical Barriers to Trade (TBT) see the following URL: www.iso.org/iso/foreword.html.

The committee responsible for this document is ISO/TC 44, *Welding and allied processes*, Subcommittee SC 6, *Resistance welding and allied mechanical joining*.

Requests for official interpretations of any aspect of this document should be directed to the Secretariat of ISO/TC 44/SC 6 via your national standards body. A complete listing of these bodies can be found at www.iso.org.

Resistance welding — Locking tapers for electrode holders and electrode caps

1 Scope

This document specifies the dimensions and tolerances for electrode holders and of spot welding electrode caps, where a locking taper is used.

2 Normative references

The following documents are referred to in the text in such a way that some or all of their content constitutes requirements of this document. For dated references, only the edition cited applies. For undated references, the latest edition of the referenced document (including any amendments) applies.

ISO 5182, *Resistance welding — Materials for electrodes and ancillary equipment*

ISO 5821, *Resistance welding — Spot welding electrode caps*

3 Terms and definitions

For the purposes of this document, the terms and definitions given in ISO 17677-1 and the following apply.

ISO and IEC maintain terminological databases for use in standardization at the following addresses:

- IEC Electropedia: available at <http://www.electropedia.org/>
- ISO Online browsing platform: available at <http://www.iso.org/obp>

3.1

locking taper

taper allowing for a tight fit between an electrode holder and the electrode cap as their taper angles differ by $0^{\circ} 2' 60''$, ensuring the electrode cap engagement point is at the skirt of the cap and electrode holder

Note 1 to entry: See [Figure 1](#).

Note 2 to entry: Traditionally called “Fisher taper”.

Note 3 to entry: During welding, the electrode cap tightens further on the electrode holder.

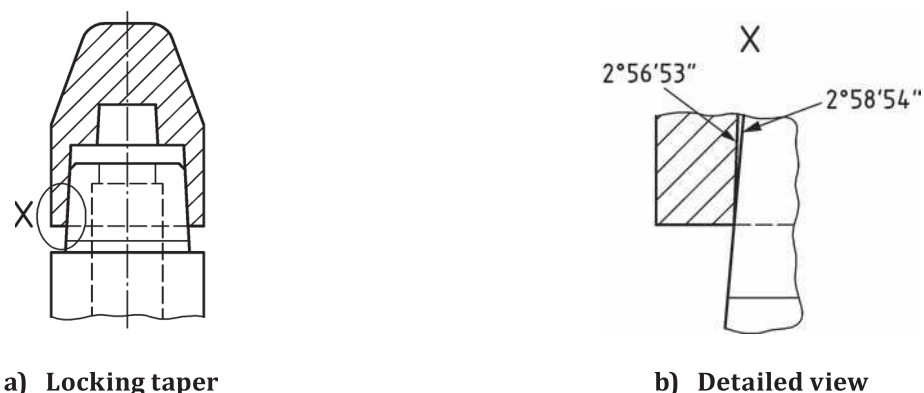

Figure 1 — Principle of a locking taper

4 Dimensions and tolerances

4.1 General

Table 1 gives the dimensions for three typically used electrode cap and holder sizes: 13 mm, 16 mm and 20 mm.

The taper angles of electrode caps and holders are to be verified by the use of certified ring gauges and plugs.

4.2 Electrode holders

The taper of the electrode holders shall be $2^{\circ} 58' 54''$ in accordance with Figure 2.

4.3 Electrode caps

The taper of the electrode caps shall be $2^{\circ} 56' 53''$ in accordance with Figure 2.

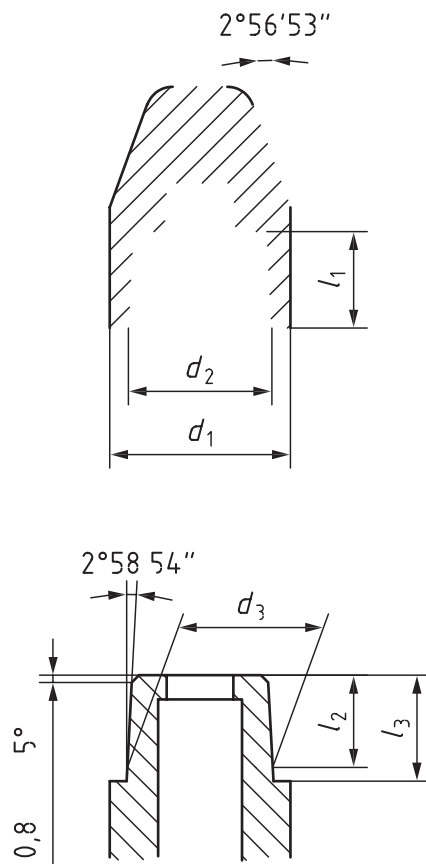

Key

- | | | | |
|-------|--|-------|---|
| l_1 | electrode cap locking taper length | d_1 | outside diameter of electrode cap |
| l_2 | electrode holder locking taper length | d_2 | inside diameter of electrode cap (at base of locking taper) |
| l_3 | total length of electrode holder taper | d_3 | diameter of electrode holder at base of locking taper |

Figure 2 — Dimensions for electrode holder and electrode cap with locking taper

Table 1 — Tolerances for the dimensions for electrode holders and electrode caps with locking tapers

Dimensions in millimetres

d_1 Nominal size of electrode cap and holder	d_2 +0,05 0	d_3 0 -0,05	l_1 +0,5 0	l_2 +0,5 0	l_3 +0,5 0
13	10,01	10,21	8,81	8,84	10,36
16	12,56	12,75	9,63	9,65	11,18
20	15,88	16,08	10,69	10,19	11,71

5 Designation

5.1 Electrode holders

Electrode holders shall be designated in accordance with this document and nominal diameter, d_1 .

EXAMPLE A spot welding electrode holder, with nominal diameter 20 mm is designated as follows:

ISO 20168:2016 - 20

5.2 Electrode caps

Electrode caps shall be designated in accordance with ISO 5821, except the number of this document shall be used to indicate that the cap has a locking taper.

EXAMPLE A spot welding electrode cap type B0, width $d_1 = 16$ mm, length $l_1 = 20$ mm, $d_2 = 8$ mm and $a = 45^\circ$, is designated as follows:

ISO 20168:2016-B0 - 16 - 20 - 8 - 45

6 Material

The materials used shall be in accordance with ISO 5182.

7 Marking

The packaging shall be marked with the full designation and material used.

Bibliography

- [1] ISO 286-2, *Geometrical product specifications (GPS) — ISO code system for tolerances on linear sizes — Part 2: Tables of standard tolerance classes and limit deviations for holes and shafts*
- [2] ISO 1119, *Geometrical product specifications (GPS) — Series of conical tapers and taper angles*
- [3] ISO 5822, *Spot welding equipment — Taper plug gauges and taper ring gauges*
- [4] ISO 17677-1, *Resistance welding — Vocabulary — Part 1: Spot, projection and seam welding*

