**Agricultural vehicles — Mechanical
connections on towed vehicles —
Dimensions for hitch rings**

*Véhicules agricoles — Liaisons mécaniques sur véhicules remorqués —
Dimensions des anneaux d'attelage*



PDF disclaimer

This PDF file may contain embedded typefaces. In accordance with Adobe's licensing policy, this file may be printed or viewed but shall not be edited unless the typefaces which are embedded are licensed to and installed on the computer performing the editing. In downloading this file, parties accept therein the responsibility of not infringing Adobe's licensing policy. The ISO Central Secretariat accepts no liability in this area.

Adobe is a trademark of Adobe Systems Incorporated.

Details of the software products used to create this PDF file can be found in the General Info relative to the file; the PDF-creation parameters were optimized for printing. Every care has been taken to ensure that the file is suitable for use by ISO member bodies. In the unlikely event that a problem relating to it is found, please inform the Central Secretariat at the address given below.

© ISO 2001

All rights reserved. Unless otherwise specified, no part of this publication may be reproduced or utilized in any form or by any means, electronic or mechanical, including photocopying and microfilm, without permission in writing from either ISO at the address below or ISO's member body in the country of the requester.

ISO copyright office
Case postale 56 • CH-1211 Geneva 20
Tel. + 41 22 749 01 11
Fax + 41 22 749 09 47
E-mail copyright@iso.ch
Web www.iso.ch

Printed in Switzerland

Foreword

ISO (the International Organization for Standardization) is a worldwide federation of national standards bodies (ISO member bodies). The work of preparing International Standards is normally carried out through ISO technical committees. Each member body interested in a subject for which a technical committee has been established has the right to be represented on that committee. International organizations, governmental and non-governmental, in liaison with ISO, also take part in the work. ISO collaborates closely with the International Electrotechnical Commission (IEC) on all matters of electrotechnical standardization.

International Standards are drafted in accordance with the rules given in the ISO/IEC Directives, Part 3.

Draft International Standards adopted by the technical committees are circulated to the member bodies for voting. Publication as an International Standard requires approval by at least 75 % of the member bodies casting a vote.

Attention is drawn to the possibility that some of the elements of this International Standard may be the subject of patent rights. ISO shall not be held responsible for identifying any or all such patent rights.

International Standard ISO 20019 was prepared by Technical Committee ISO/TC 23, *Tractors and machinery for agriculture and forestry*, Subcommittee SC 4, *Tractors*.

This first edition of ISO 20019 cancels and replaces ISO 5692:1979, which has been technically revised.

Agricultural vehicles — Mechanical connections on towed vehicles — Dimensions for hitch rings

1 Scope

This International Standard specifies dimensional requirements for the attachment of agricultural, non-balanced trailers and implements by means of hitch rings to the rear of towing vehicles equipped with a hook specified in ISO 6489-1. Its purpose is to ensure the interchangeability of the mechanical connections on agricultural towed vehicles.

This International Standard is applicable to rings whose coupling point is below the centre-line of the rear axle and the power take-off (PTO) of the tractor.

NOTE Other International Standards are to be developed for rings above the PTO coupling.

2 Normative reference

The following normative document contains provisions which, through reference in this text, constitute provisions of this International Standard. For dated references, subsequent amendments to, or revisions of, any of these publications do not apply. However, parties to agreements based on this International Standard are encouraged to investigate the possibility of applying the most recent editions of the normative document indicated below. For undated references, the latest edition of the normative document referred to applies. Members of ISO and IEC maintain registers of currently valid International Standards.

ISO 6489-1:2001, *Agricultural vehicles — Mechanical connections between towed and towing vehicles — Part 1: Dimensions of hitch hooks*

3 Interchangeability dimensions

3.1 General

The hitch ring and shank shall have the dimensions given in Figures 1 to 3. Interchangeability is ensured provided that the attachment on the towing vehicle is in accordance with ISO 6489-1.

3.2 Trailer shank travel angles

When the trailer shank fitted with the specified hitch ring is fixed to the tractor attachment, the shank shall be free to turn so that the angles formed with the horizontal situated in the tractor's plane of symmetry and passing through the coupling point have the following minimum values.

- **Angle of yaw:** rotation around a vertical axis passing through the coupling point, minimum value of 60° on both sides.
- **Angle of pitch:** rotation around a horizontal axis passing through the coupling point and perpendicular to the vehicle's longitudinal plane of symmetry, minimum value of 20° top and bottom.

Allowance should be made for the towing vehicle being up to $\pm 3^\circ$ from the horizontal, due to the front or rear tyre sizes.

- **Angle of roll:** rotation around a horizontal axis passing through the coupling point and located in the vehicle's plane of symmetry, minimum value of 20° top and bottom.

4 Construction

Hitch rings in accordance with this International Standard shall be substantially toroidal and shall be manufactured by forging. Shanks shall be forged or machined or both.

The hitch ring shall be fixed on the shank. The hitch hook on the tractor shall be designed to allow for the travel angles specified in 3.2.

In addition to these requirements, relating to fixed hitch rings for towed vehicles, only the towed member (i.e. hitch ring and shank) shall have the option of providing rotational freedom of up to 360° around the shank's horizontal longitudinal axis (roll). Limitation of rotation away from horizontal, or bias towards the hitch ring remaining horizontal, is optional.

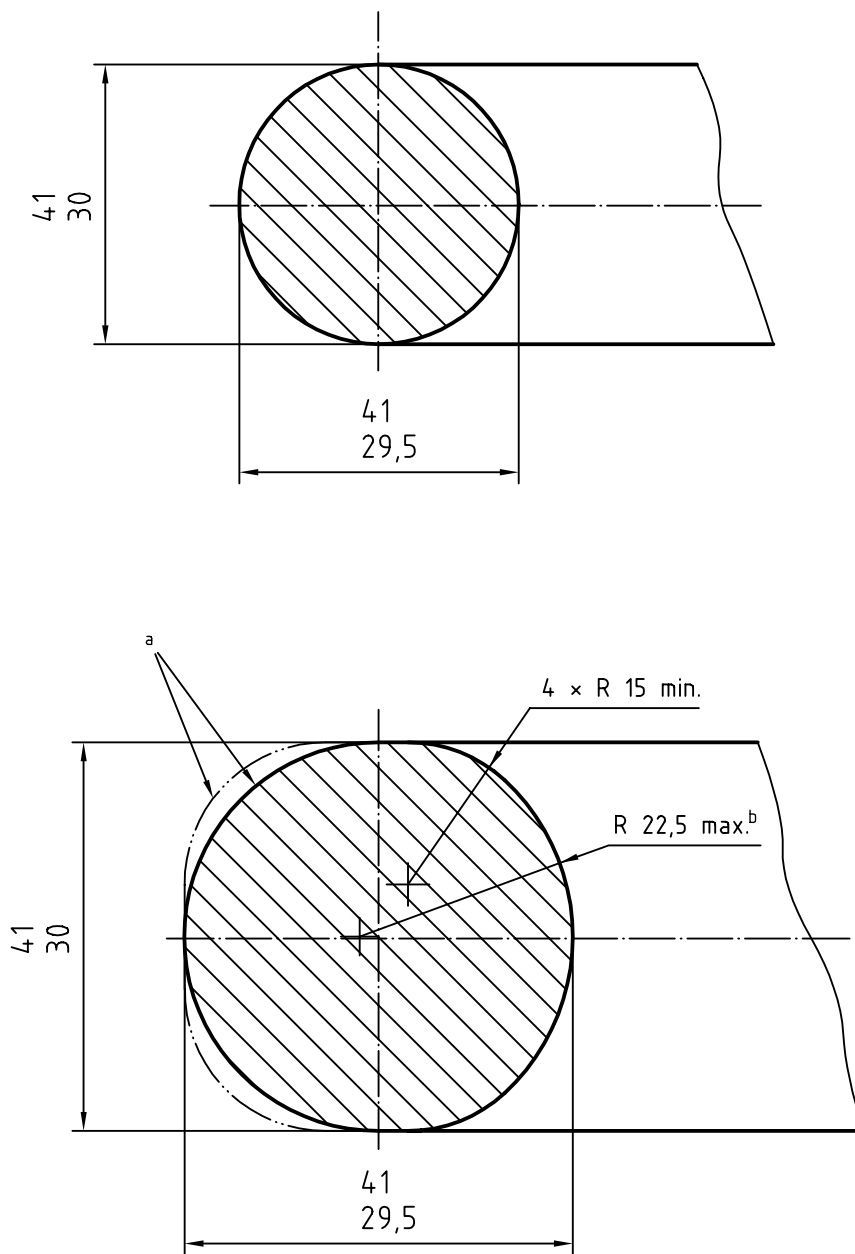

^a Alternative outer contour: outer radius 22.5 max. and 15 min. blend radius top and bottom, or min. top and bottom blend radius to flat outer surface.

^b Internal contour.

Figure 1 — Hitch ring — Section options

Dimensions in millimetres

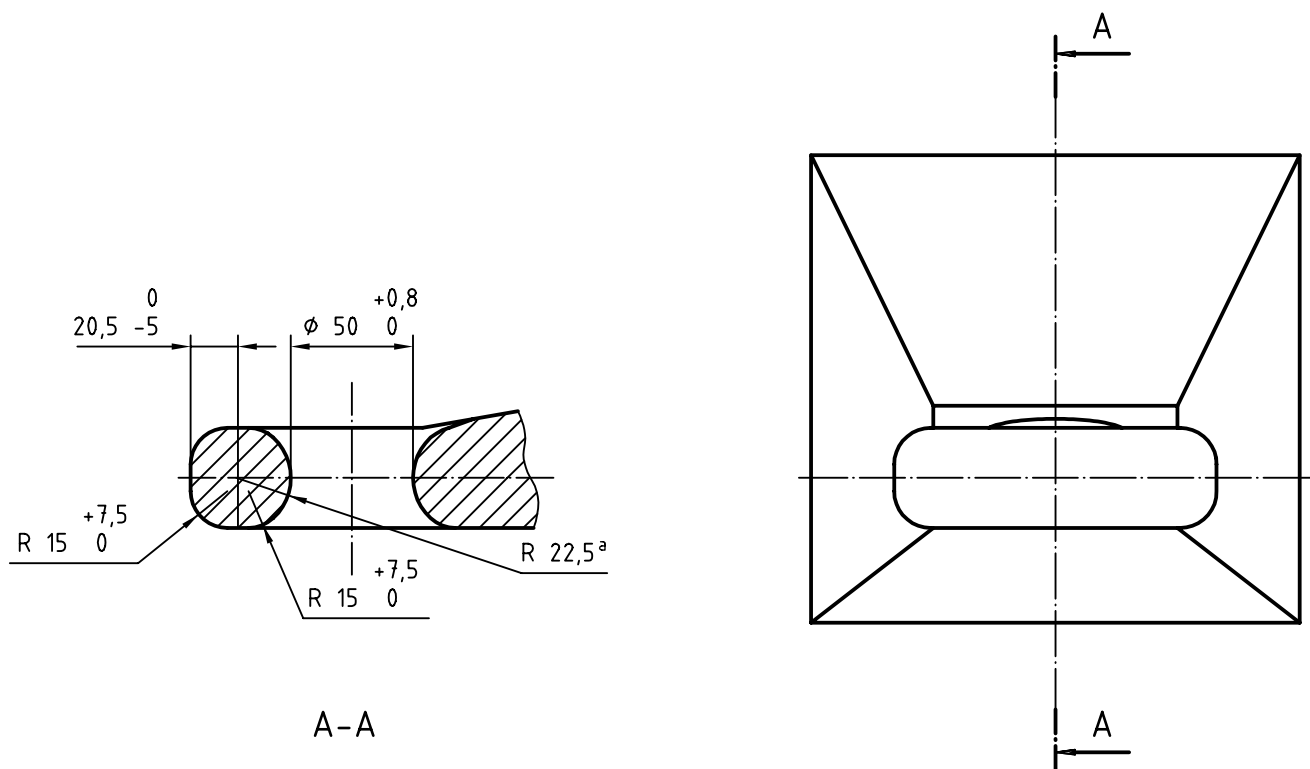

^a Internal contour.

Figure 2 — Hitch ring dimensions

Dimensions in millimetres

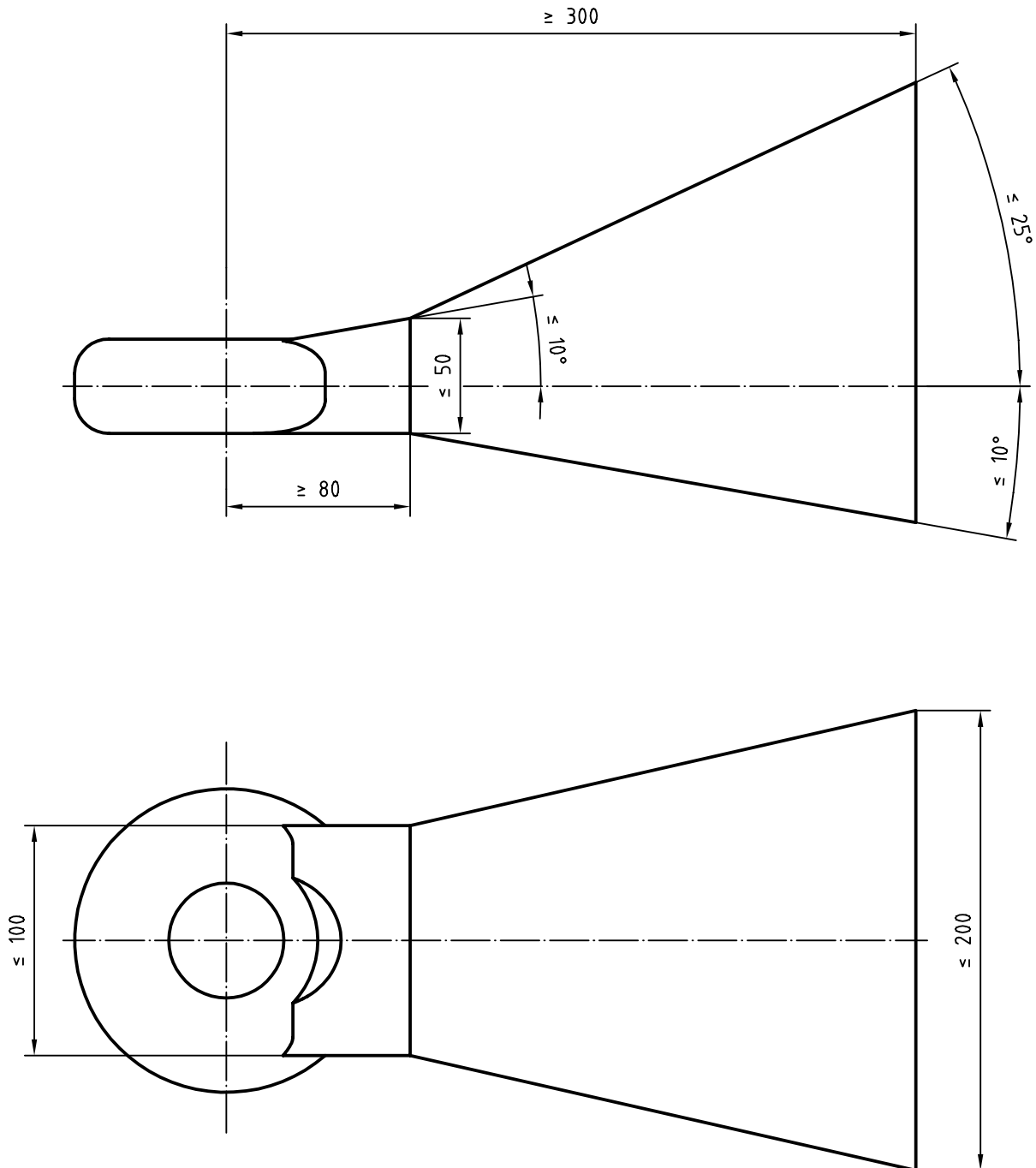

Figure 3 — Hitch shank dimensions

