

TECHNICAL
SPECIFICATION

ISO/TS
22113

IDF/RM
204

First edition
2012-07-01

Milk and milk products — Determination of the titratable acidity of milk fat

*Lait et produits laitiers — Détermination de l'acidité titrable de la matière
grasse laitière*



Reference numbers
ISO/TS 22113:2012(E)
IDF/RM 204:2012(E)

© ISO and IDF 2012



COPYRIGHT PROTECTED DOCUMENT

© ISO and IDF 2012

All rights reserved. Unless otherwise specified, no part of this publication may be reproduced or utilized in any form or by any means, electronic or mechanical, including photocopying and microfilm, without permission in writing from either ISO or IDF at the respective address below.

ISO copyright office
Case postale 56 • CH-1211 Geneva 20
Tel. + 41 22 749 01 11
Fax + 41 22 749 09 47
E-mail copyright@iso.org
Web www.iso.org

International Dairy Federation
Silver Building • Boulevard Auguste Reyers 70/B • B-1030 Brussels
Tel. + 32 2 733 98 88
Fax + 32 2 733 04 13
E-mail info@fil-idf.org
Web www.fil-idf.org

Published in Switzerland

Contents	Page
Foreword	iv
1 Scope	1
2 Principle	1
3 Reagents	1
4 Apparatus	3
5 Sampling	4
6 Preparation of test samples	4
6.1 Storage and preservation	4
6.2 Pretreatment of test sample	4
7 Procedure	4
7.1 Separation of fat	4
7.2 Titration	5
8 Calculation and expression of results	5
8.1 Calculation	5
8.2 Expression of results	6
9 Precision	6
9.1 Interlaboratory test	6
9.2 Repeatability	6
10 Test report	6
Annex A (informative) Models for the fat separation tubes	7
Annex B (informative) Typical titration device for consecutive titration of several samples in one volume of fat solvent	8
Annex C (informative) Guidelines for the preparation and implementation of reference fat samples for the follow-up of the titration procedure	9
Annex D (informative) Interlaboratory trial	13
Bibliography	14

Foreword

ISO (the International Organization for Standardization) is a worldwide federation of national standards bodies (ISO member bodies). The work of preparing International Standards is normally carried out through ISO technical committees. Each member body interested in a subject for which a technical committee has been established has the right to be represented on that committee. International organizations, governmental and non-governmental, in liaison with ISO, also take part in the work. ISO collaborates closely with the International Electrotechnical Commission (IEC) on all matters of electrotechnical standardization.

International Standards are drafted in accordance with the rules given in the ISO/IEC Directives, Part 2.

The main task of technical committees is to prepare International Standards. Draft International Standards adopted by the technical committees are circulated to the member bodies for voting. Publication as an International Standard requires approval by at least 75 % of the member bodies casting a vote.

In other circumstances, particularly when there is an urgent market requirement for such documents, a technical committee may decide to publish other types of document:

- an ISO Publicly Available Specification (ISO/PAS) represents an agreement between technical experts in an ISO working group and is accepted for publication if it is approved by more than 50 % of the members of the parent committee casting a vote;
- an ISO Technical Specification (ISO/TS) represents an agreement between the members of a technical committee and is accepted for publication if it is approved by 2/3 of the members of the committee casting a vote.

An ISO/PAS or ISO/TS is reviewed after three years in order to decide whether it will be confirmed for a further three years, revised to become an International Standard, or withdrawn. If the ISO/PAS or ISO/TS is confirmed, it is reviewed again after a further three years, at which time it must either be transformed into an International Standard or be withdrawn.

Attention is drawn to the possibility that some of the elements of this document may be the subject of patent rights. ISO shall not be held responsible for identifying any or all such patent rights.

ISO/TS 22113|IDF/RM 204 was prepared by Technical Committee ISO/TC 34, *Food products*, Subcommittee SC 5, *Milk and milk products*, and the International Dairy Federation (IDF). It is being published jointly by ISO and IDF.

Foreword

IDF (the International Dairy Federation) is a non-profit organization representing the dairy sector worldwide. IDF membership comprises National Committees in every member country as well as regional dairy associations having signed a formal agreement on cooperation with IDF. All members of IDF have the right to be represented on the IDF Standing Committees carrying out the technical work. IDF collaborates with ISO in the development of standard methods of analysis and sampling for milk and milk products.

The main task of Standing Committees is to prepare International Standards. Draft International Standards adopted by the Standing Committees are circulated to the National Committees for endorsement prior to publication as an International Standard. Publication as an International Standard requires approval by at least 50 % of IDF National Committees casting a vote.

In other circumstances, particularly when there is an urgent market requirement for such documents, a Standing Committee may decide to publish an other type of normative document which is called by IDF: *Reviewed method*. Such a method represents an agreement between the members of a Standing Committee and is accepted for publication if it is approved by at least 50 % of the committee members casting a vote. A *Reviewed method* is equal to an ISO/PAS or ISO/TS and will, therefore, also be published jointly under ISO conditions.

Attention is drawn to the possibility that some of the elements of this document may be the subject of patent rights. IDF shall not be held responsible for identifying any or all such patent rights.

ISO/TS 22113|IDF/RM 204 was prepared by the International Dairy Federation (IDF) and Technical Committee ISO/TC 34, *Food products*, Subcommittee SC 5, *Milk and milk products*. It is being published jointly by IDF and ISO.

All work was carried out by Joint ISO-IDF Project Group (C01) on *Determination of titratable acidity of fat (BDI method)* of the *Standing Committee on Analytical Methods for Composition (SCAMC)* under the aegis of its project leader, P. Trossat (FR).

Milk and milk products — Determination of the titratable acidity of milk fat

1 Scope

This Technical Specification specifies a routine method for determining the titratable acidity of milk fat.

The method is applicable to milk fat obtained from:

- a) raw milk;
- b) heat-treated milk;
- c) milk reconstituted from milk powder;
- d) cream with any fat content, provided the product is diluted so as to obtain a mass fraction of between 4 % and 6 % fat.

The method is not applicable to fermented milk or milk that has undergone bacterial or enzymatic damage.

NOTE 1 The titration procedure can also be applied to fat separated from several other dairy products.

NOTE 2 This Technical Specification is designed for batches of test samples of between five and several hundred test portions per day.

2 Principle

An amount of sample is thoroughly mixed with a solution containing sodium tetrphosphate and a surface-active agent. The mixture is heated in a boiling water bath to obtain separation of fat. A known quantity of extracted fat is dissolved in an organic solvent and titrated with alcoholic alkali.

3 Reagents

Use only reagents of recognized analytical grade, unless otherwise specified, and distilled or demineralized water or water of equivalent purity.

3.1 Phosphoric acid solution, $c(\text{H}_3\text{PO}_4) \approx 1 \text{ mol/l}$.

3.2 BDI¹⁾ reagent. Dissolve 70 g of sodium tetrphosphate in about 700 ml distilled water without additional warming and mix.

1) The acronym "BDI" stands for Bureaux of Dairy Industries; this organization first developed this method.

Add 30 g of octylphenylpoly(ethyleneglycol)²⁾ and mix again. Adjust the pH to 6,6 with phosphoric acid solution (3.1), if needed. Dilute to 1 l with water and mix. If necessary, readjust the pH with phosphoric acid solution (3.1).

If stored in a refrigerator and in the dark, the BDI reagent is stable for 1 month.

NOTE Sodium tetrphosphate is a polyphosphate containing sodium tetrphosphate (NaPO_3)₄ as the main component besides some other polyphosphates.

3.3 Thymol blue solution, $c(\text{C}_{27}\text{H}_{30}\text{O}_5\text{S}) = 0,1 \text{ g/l}$ in propan-2-ol.

Dissolve 0,1 g sodium salt of thymol blue in 100 ml of propan-2-ol to prepare a stock solution. Directly before use, dilute one volume of the stock solution with nine volumes of propan-2-ol.

3.4 Fat solvent solution. Mix one volume of thymol blue solution (3.3) with four volumes light petroleum with a boiling range between 60 °C and 80 °C.

The fat solvent solution can be stored in the dark for up to 1 month.

3.5 Potassium hydrogen phthalate solution, $c(\text{KHC}_8\text{H}_4\text{O}_4) = 0,01 \text{ mol/l}$.

Dissolve 1,021 1 g of potassium hydrogen phthalate in a 500 ml one-mark volumetric flask (4.11). Dilute to the 500 ml mark with water and mix.

3.6 Tetra-*n*-butylammonium hydroxide solution, $c(\text{C}_{16}\text{H}_{37}\text{NO}) = 0,01 \text{ mol/l}$ in a propan-2-ol and methanol mixture.

Dilute one volume of tetra-*n*-butylammonium hydroxide, $c[(\text{C}_4\text{H}_9)_4\text{NOH}] = 0,1 \text{ mol/l}$ in a propan-2-ol and methanol mixture, with nine volumes of propan-2-ol to obtain a final concentration of $c(\text{C}_{16}\text{H}_{37}\text{NO}) = 0,01 \text{ mol/l}$.

The concentration of the tetra-*n*-butylammonium hydroxide solution may change on storage and when being transferred to the burette. For these reasons, determine the actual concentration of the solution to four decimal places before use by titration against a standard solution of potassium hydrogen phthalate (3.5) using the thymol blue solution (3.3) as indicator.

If the burette is fitted with a facility to exclude the entry of carbon dioxide, the concentration is stable for 1 month.

3.7 Pilot fat and reference fat.

3.7.1 Pilot fat. Melt some anhydrous milk fat (e.g. 1 000 g) having a fat acidity level of between 0,5 mmol/100 g and 1,0 mmol/100 g of fat. Divide the melted anhydrous milk fat sample into subsamples (e.g. of 5 g each).

If stored in a freezer at -20 °C or below, the pilot fat subsamples can be kept for at least 2 years.

The pilot fat samples can be used for checking the reproducibility of the results obtained by the titration procedure (7.2), either during a single work session or between work sessions over a long period of time (several months to years).

3.7.2 Reference fat. Reference fat samples consist of milk fat of low fat acidity (basic fat) spiked with increasing levels of palmitic acid (C_{16}) within the range 0,5 mmol/100 g to 1,5 mmol/100 g per 100 g fat.

2) Triton X-100 is an example of a suitable product available commercially. This information is given for the convenience of users of this document, and does not constitute an endorsement by ISO and IDF of this product.

The accuracy of the titration procedure can be checked by using the regression Equation (1):

$$b(C_{16}) = \alpha + \beta \Delta b \quad (1)$$

where

$b(C_{16})$ is the amount of palmitic acid, expressed in mmol per 100 g fat, added to the basic fat;

Δb is the BDI value of the spiked samples decreased by the BDI value of the basic fat (blank).

The preparation and the guidelines for use of these reference fat samples are described in Annex C.

4 Apparatus

Usual laboratory equipment and, in particular, the following.

4.1 Delivery pipettes or syringes, capacities 10 ml, 25 ml, and 50 ml.

4.2 Fat separation tubes, consisting of a bulk vat surmounted by a narrow stem for collecting the small quantity of fat extracted from the reagent mixture. The diameter of the stem shall be large enough to allow the calibrated syringe (4.5) to take a fat sample. Models of fat separation tubes are given in Annex A. Butyrometers according to ISO 3432|IDF 221^[3] can also be used.

NOTE The fat separation is enhanced by centrifugation, especially in tubes with narrow stems.

4.3 Water bath, capable of maintaining a temperature of $45\text{ }^{\circ}\text{C} \pm 1\text{ }^{\circ}\text{C}$.

4.4 Boiling water bath, capable of maintaining a temperature of $\geq 95\text{ }^{\circ}\text{C}$.

4.5 Calibrated syringe, adjustable and capable of delivering a known quantity of milk fat of about 0,25 g at $45\text{ }^{\circ}\text{C}$, being accurate to 2 mg of milk fat.

NOTE From experience, transfer of a quantity of fat can be done accurately and conveniently by using a positive displacement pipette.

4.6 Titration vessel, capacity of between 10 ml and 100 ml depending on the volumes of test samples to be titrated in one titration run, provided with a stirring device.

4.7 Microburette, graduated in divisions of at least 0,002 ml.

4.8 Nitrogen supply, free of carbon dioxide.

4.9 Gas washbottle, containing light petroleum with a boiling range of $60\text{ }^{\circ}\text{C}$ to $80\text{ }^{\circ}\text{C}$, connected to the nitrogen supply (4.8) and the titration vessel (4.6).

4.10 Colorimeter, with dip-probe, suitable for measuring at a wavelength of between 600 nm and 620 nm, connectable to the titration vessel (4.6).

4.11 One-mark volumetric flasks, capacities 100 ml to 500 ml, ISO 1042,^[2] class A.

NOTE 1 The titration vessel (4.6), the microburette (4.7) for delivering the non-aqueous titrant tetra-*n*-butylammonium hydroxide (3.6), the nitrogen supply (4.8) through a gas washbottle (4.9) and the dip-probe connected to the colorimeter (4.10) are assembled in a typical device (see Annex B) for consecutive titration of several samples in one and the same volume of fat solvent.

NOTE 2 A simpler device for manual titration and visual determination of the endpoint of titration can be set up without a colorimeter with dip-probe.

5 Sampling

Sampling is not part of the method specified in this Technical Specification. A recommended sampling method is given in ISO 707|IDF 50.^[1]

It is important the laboratory receive a truly representative sample which has not been damaged or changed during transport or storage.

6 Preparation of test samples

6.1 Storage and preservation

The milk or cream test samples shall have been stored and transported at 0 °C to 4 °C (milk powder can be stored at ambient temperature) and be analysed within 36 h.

For prolonged storage or storage in a refrigerator at ~5 °C, it is recommended that test samples be preserved by means of hydrogen peroxide at a final concentration of 0,2 g/l H₂O₂. In this case, the test samples can be stored for 4 days.

6.2 Pretreatment of test sample

6.2.1 Milk sample

Mix gently by inverting the test sample several times, without increasing its temperature.

6.2.2 Cream sample

Dilute cream sample using the corresponding skim milk or water to obtain a mass fraction of between 4 % and 6 % fat.

Using water to dilute cream results in an underestimation of the free fatty acid (FFA) level compared to the parent milk. In these cases, use a correction programme to obtain accurate results (see Reference [8]).

6.2.3 Milk powder sample

Dissolve around 13 g of milk powder in a 100 ml one-mark volumetric flask (4.11). Add 60 ml of water and mix using a mixer at room temperature for 70 min. Dilute to the 100 ml mark with water and mix.

7 Procedure

7.1 Separation of fat

Mix 3,5 parts (± 3 %) of test sample (milk, cream diluted or reconstituted milk powder) (6.2) to 1 part ($\pm 1,5$ %) of BDI reagent (3.2) in the tube for fat separation using the following amounts:

- when using a MONED tube (4.2), mix 31 ml \pm 1 ml of test sample (6.2) and 8,9 ml \pm 0,1 ml of BDI reagent (3.2);
- when using a Van Gulik butyrometer (4.2), mix 16,0 ml \pm 0,5 ml of test sample (6.2) and 4,5 ml \pm 0,1 ml of BDI reagent (3.2);
- when using other tubes, mix volume fractions of the test sample (6.2) and the BDI reagent in ratio 3,5 + 1 using volumes such that a fat column exists in the stem of the extraction tube (4.2).

Immediately after filling, close the fat separation tube and mix its content.

For a test sample taken from raw milk, mix gently by inverting the tube several times. For test samples taken from heat-treated milk or reconstituted milk powder, shake more intensively in order to achieve good separation of the fat.

As soon as possible, but within 5 min, place the tube in the boiling water bath (4.4) maintained at a temperature of ≥ 95 °C for 15 min. Take care that the temperature of the water bath stays above 95 °C and its water level above the upper level of the tube content.

For tubes with narrow stems and milk samples other than raw milk, it can prove necessary to centrifuge the tubes to achieve better fat separation.

In the case of a bad fat separation, place the tubes in a refrigerator to solidify the fat. After reheating in the boiling water bath, fat separation is enhanced. In any case, the fat shall be limpid and free from any particles.

Once the fat extraction is achieved, put the tube in the water bath (4.3) at 45 °C. Ensure that its water level remains above the upper level of the tube content.

7.2 Titration

Perform the titration in the titration vessel (4.6) under a carbon dioxide-free atmosphere. Connect the titration vessel to the nitrogen supply (4.8) coming from the gas washbottle (4.9). Regularly fill the gas washbottle to compensate for the evaporation of the petroleum ether.

Transfer a suitable volume of fat solvent (3.4) and 0,25 g of pilot fat (3.7.1) into the titration vessel (4.6) being free from carbon dioxide by nitrogen flushing (4.8).

Control the wavelength setting of the colorimeter. Adjust the colorimeter scale at 0 % (dark) and at 100 % (fat solvent with fat sample) transmission.

Adjust the endpoint of the titration at 70 % on the transmission scale. Neutralize the fat solvent with the tetra-*n*-butylammonium hydroxide solution (3.6).

Using the calibrated syringe (4.5), add a known quantity of about 0,25 g of the pilot fat and titrate. Always repeat the procedure five times to fulfil the requirements mentioned for repeatability (9.2).

If the results obtained for the pilot fat are out of the range of the repeatability limits, check the titration device (Annex B) and the titration procedure.

Using the calibrated syringe (4.5), transfer a test portion of about 0,25 g of the prepared fat sample (7.1) to the titration vessel and titrate.

Replace the fat solvent with fresh solvent when three titrations have been carried out per 2 ml fat solvent (e.g. 60 titrations in a volume of 40 ml fat solvent).

When titrating a small number of test samples only, the endpoint titration can be estimated by visual observation of the change in colour (yellow to faint greenish). At least two titrations can be carried out in 5 ml fat solvent.

8 Calculation and expression of results

8.1 Calculation

Calculate the fat acidity of the test sample, b_{H^+} , expressed in millimoles per 100 g of fat, by using Equation (2):

$$b_{H^+} = \frac{V_c}{m} \times 100 \quad (2)$$

where

- V is the volume, in millilitres, expressed to three decimal places, of the tetra-*n*-butylammonium hydroxide solution (3.6) used in the titration;
- c is the exact concentration, in moles per litre, expressed to four decimal places, of the tetra-*n*-butylammonium hydroxide solution (3.6);
- m is the mass, in grams, expressed to three decimal places, of fat transferred with the calibrated syringe into the titration vessel.

8.2 Expression of results

Express the test results to two decimal places.

9 Precision

9.1 Interlaboratory test

The values for the repeatability derived from this interlaboratory test were determined in accordance with ISO 5725-1^[4] and ISO 5725-2.^[5] However, only three laboratories participated in the test.

The values obtained, therefore, should only be considered as being indicative. Details of the interlaboratory test on the precision of the method are given in Annex D.

9.2 Repeatability

The absolute difference between two individual single test results, obtained with the same method on identical test material in the same laboratory by the same operator using the same equipment within a short interval of time, will indicatively in not more than 5 % of cases be greater than 0,072 mmol/100 g.

10 Test report

The test report shall contain at least the following information:

- a) all information necessary for the complete identification of the sample;
- b) the sampling method used, if known;
- c) the test method used, together with reference to this Technical Specification (ISO/TS 22113|IDF/RM 204:2012);
- d) all operating details not specified in this Technical Specification, or regarded as optional, together with details of any incidents which may have influenced the test result(s);
- e) the test result(s) obtained;
- f) if the repeatability has been checked, the final quoted result obtained.

Annex A (informative)

Models for the fat separation tubes

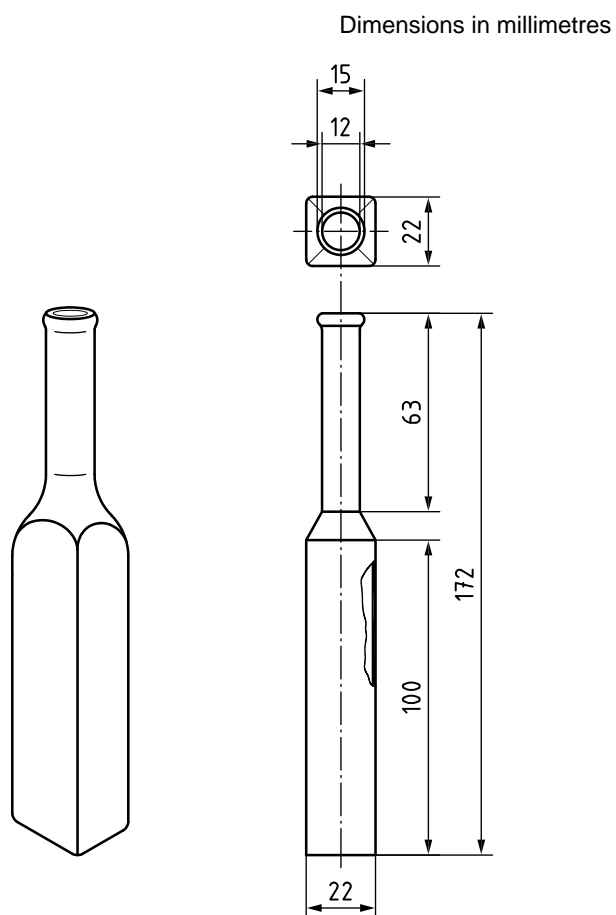
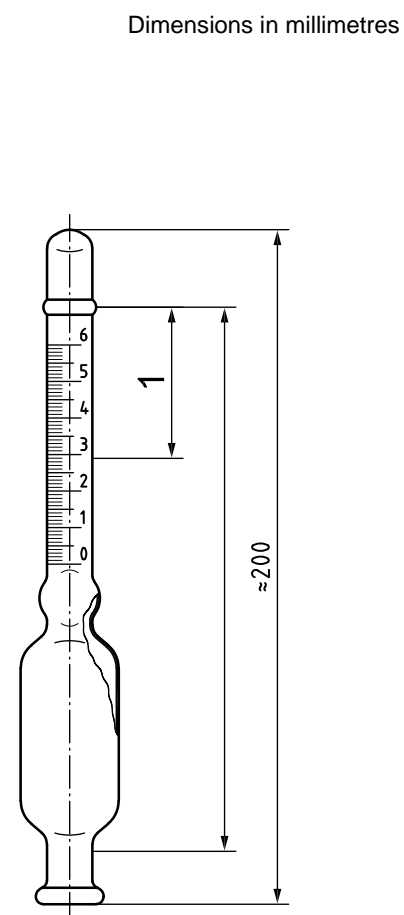

Figure A.1 — MONED tube



Key

- 1 extracted fat

Figure A.2 — General model of a fat extraction tube

Annex B (informative)

Typical titration device for consecutive titration of several samples in one volume of fat solvent

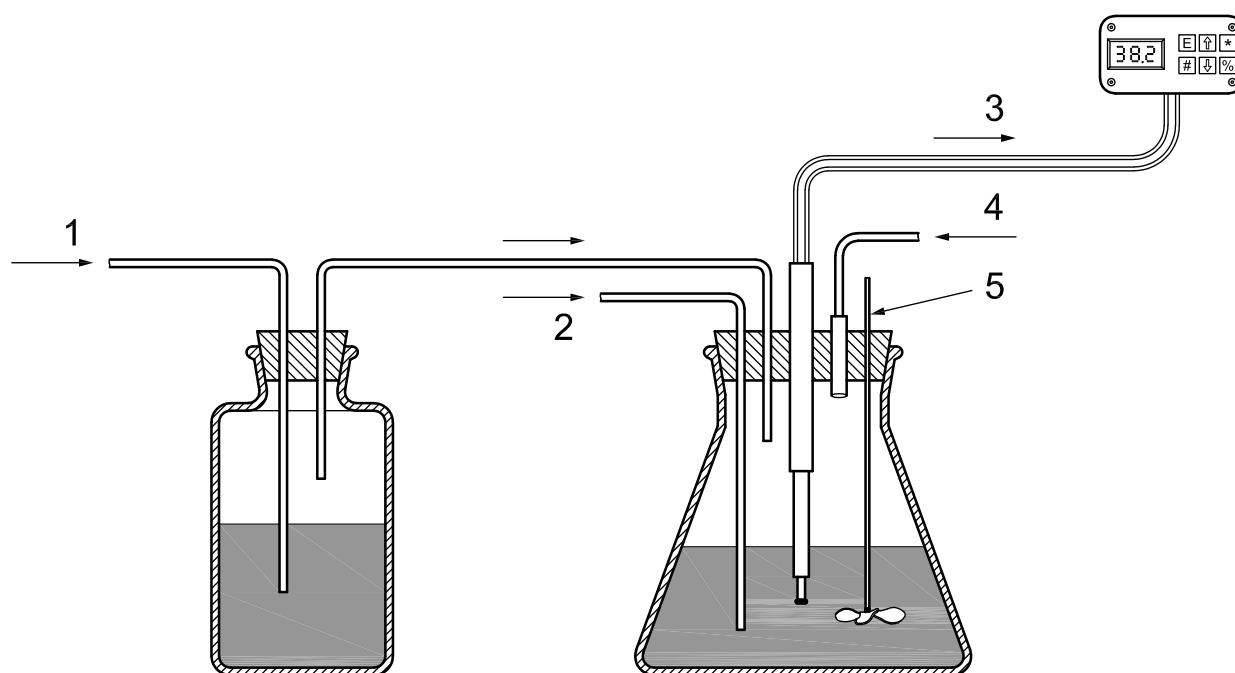

Key

- 1 nitrogen supply through a gas washbottle containing petroleum ether
- 2 inlet for basic non-aqueous titrant tetra-*n*-butylammonium hydroxide
- 3 optical probe connected to a colorimeter
- 4 inlet for the introduction of the fat solvent and the fat samples
- 5 stirring device

Figure B.1 — Typical titration device for consecutive titration

Annex C (informative)

Guidelines for the preparation and implementation of reference fat samples for the follow-up of the titration procedure

C.1 Preparation of the reference fat samples

C.1.1 Basic milk fat

Obtain an adequate amount of milk fat of low fat acidity. Melt it at 38 °C.

C.1.2 Preparation of reference fats spiked with palmitic acid (C₁₆)

C.1.2.1 Reference fat A, spiked with 1,25 mmol of palmitic acid per 100 g fat.

Weigh to the nearest 0,1 mg, 0,962 g ± 0,001 g of palmitic acid. Dissolve the palmitic acid in about 300 g of basic milk fat (C.1.1) and mix.

Weigh, to the nearest 0,01 g, the total mass of the thus prepared reference fat A.

In general, palmitic acid is not 100 % pure. The purity, therefore, has to be taken into account when weighing the palmitic acid. For instance, by implementing palmitic acid containing “at least 98 %”, the mass of palmitic to be weighed shall be about 0,962/0,98 = 0,982 g instead of 0,962 g.

Calculate the level, $b(C_{16})_{1,25}$ of the palmitic acid in the reference fat A, in millimoles per 100 g, by using Equation (C.1):

$$b(C_{16})_{1,25} = \frac{wm_1 \times 10^5}{m_2 M} \quad (C.1)$$

where

w is the numerical value of the purity, as a mass fraction, of the palmitic acid (w normally is between 0,98 and 1,00);

m_1 is the mass, in grams, of palmitic acid for the preparation of reference fat A;

m_2 is the mass, in grams, of the total amount of prepared reference fat A;

M is the molecular mass, in grams, of palmitic acid ($M = 256,43$ g/mol).

C.1.2.2 Reference fat B, spiked with 1,00 mmol of palmitic acid per 100 g fat.

Weigh, to the nearest 0,01 g, 80 g ± 0,01 g of reference fat A (C.1.2.1). Dissolve the reference fat in 20 g ± 0,01 g of basic milk fat (C.1.1) and mix.

Weigh to the nearest 0,01 g, the mass of the reference fat B thus prepared.

Calculate the level, $b(C_{16})_{1,00}$, of the palmitic acid in the reference milk fat B, expressed in millimoles per 100 g, by using Equation (C.2):

$$b(C_{16})_{1,00} = b(C_{16})_{1,25} \frac{m_3}{m_4} \quad (C.2)$$

where

m_3 is the mass, in grams, of the reference fat A dissolved in the basic milk fat;

m_4 is the mass, in grams, of the total amount of prepared reference fat B.

C.1.2.3 Reference fat C, spiked with 0,75 mmol of palmitic acid per 100 g fat.

Weigh, to the nearest 0,01 g, $60 \text{ g} \pm 0,01 \text{ g}$ of reference fat A (C.1.2.1). Dissolve the reference fat A in about $40 \text{ g} \pm 0,01 \text{ g}$ of basic milk fat (C.1.1) and mix.

Weigh to the nearest 0,01 g, the mass of the reference fat C thus prepared.

Calculate the level, $b(C_{16})_{0,75}$, of the palmitic acid in the reference milk fat C, expressed in millimoles per 100 g, by using Equation (C.3):

$$b(C_{16})_{0,75} = b(C_{16})_{1,25} \frac{m_5}{m_6} \quad (C.3)$$

where

m_5 is the mass, in grams, of the reference fat A dissolved in the basic milk fat;

m_6 is the mass, in grams, of the total amount of prepared reference fat C.

C.1.2.4 Reference fat D, spiked with 0,50 mmol of palmitic acid per 100 g fat.

Weigh, to the nearest 0,01 g, $40 \text{ g} \pm 0,01 \text{ g}$ of reference fat A. Dissolve reference fat A in $60 \text{ g} \pm 0,01 \text{ g}$ of basic milk fat (C.1.1) and mix.

Weigh, to the nearest 0,01 g, the mass of the reference fat D thus prepared.

Calculate the level, $b(C_{16})_{0,50}$, of the palmitic acid in the reference milk fat D, expressed in millimoles per 100 g, by using Equation (C.4):

$$b(C_{16})_{0,50} = b(C_{16})_{1,25} \frac{m_7}{m_8} \quad (C.4)$$

where

m_7 is the mass, in grams, of the reference fat A dissolved in the basic milk fat;

m_8 is the mass, in grams, of the total amount of prepared reference fat D.

C.2 Implementation of the reference fat samples

C.2.1 Determination of the fat acidity of the reference fat

According to the procedure (7.2), determine the fat acidity of the basic milk fat (C.1.1) (blank), b_0 , and the fat acidity values, $b_{1,25}$, $b_{1,00}$, $b_{0,75}$, and $b_{0,50}$, of the four reference fat samples.

C.2.2 Calculations and assessment of the results

Table C.1 — Calculations

Sample identity	Level of palmitic acid in the reference fat samples $b(C_{16})_{i, \text{ref}}$	BDI value determined according to 7.2	Δb_N $(b_i - b_0)$	Ratio $\Delta b_N / b(C_{16})_{i, \text{ref}}$
Basic fat (blank)		b_0		
Reference fat A	$b(C_{16})_{1,25}$	$b_{1,25}$	Δb_A	$[\Delta b_A / b(C_{16})_{1,25}]_A$
Reference fat B	$b(C_{16})_{1,00}$	$b_{1,00}$	Δb_B	$[\Delta b_B / b(C_{16})_{1,00}]_B$
Reference fat C	$b(C_{16})_{0,75}$	$b_{0,75}$	Δb_C	$[\Delta b_C / b(C_{16})_{0,75}]_C$
Reference fat D	$b(C_{16})_{0,50}$	$b_{0,50}$	Δb_D	$[\Delta b_D / b(C_{16})_{0,50}]_D$

To recapitulate the quantities shown in Table C.1:

- column 2 lists the levels of palmitic acid in reference fats A, B, C, and D;
- column 3 lists the BDI values of reference fats A, B, C, and D, determined according to the titration procedure (7.2);
- column 4 lists the values Δb_A , Δb_B , Δb_C , and Δb_D , calculated by subtracting the BDI value of the basic fat, b_0 , from the BDI values of reference fats A, B, C, and D.

For each of the reference fat samples, calculate the ratios: $\Delta b_N / b(C_{16})_{i, \text{ref}}$, where N is A, B, C, and D, and i is 1,25, 1,00, 0,75, and 0,50, respectively.

Calculate also the residual standard deviation, $s_{b(C_{16})_{p,b}}$, of the regression Equation (C.5):

$$b(C_{16})_p = \alpha + \beta b \quad (\text{C.5})$$

where

$b(C_{16})_p$ represents the predicted palmitic acid level in the reference fat samples (C.1.1);

b represents the BDI value of the reference fat samples (C.1.2).

If either one or more of the ratios $\Delta b_N / b(C_{16})_{i, \text{ref}}$ are out of the range: $1,00 \pm 0,05$ (i.e. if results deviate more than 5 % from the predicted values) or if the residual standard deviation $s_{b(C_{16})_{p,b}} > 0,02$ mmol / 100 g fat, check the titration solution (3.6), the titration device (Annex B) and the titration procedure (7.2).

ISO/TS 22113:2012(E)
IDF/RM 204:2012(E)

After these verifications, if good repeatability of the titration results on pilot fat (3.7.1) and reference fat samples (3.7.2) is confirmed, but deviations are still outside the range $1,00 \pm 0,05$, a systematic but reproducible deviation of the results of titration exists. This problem first has to be solved in order to obtain reliable results.

NOTE This systematic error is most probably due to an error in the estimation of the volumes actually delivered by the calibrated syringe (4.5) or by the microburette (4.7).

Annex D (informative)

Interlaboratory trial

An interlaboratory double blind collaborative test involving three laboratories was carried out on six test samples. Included in the test were:

- a) two fluid milk test samples (S1 and S2);
- b) two dried milk test samples (S3 and S4);
- c) two cream test samples (S5 and S6).

The test samples were prepared and distributed by Cecalait, Poligny (FR), which also performed the statistical analysis as shown in Table D.1.

Table D.1 — Results of the trial

Parameter	Sample						Mean
	S1	S2	S3	S4	S5	S6	
No. participating laboratories	3	3	3	3	3	3	
Mean value, mmol/100 g fat	1,273	0,674	0,593	0,484	0,331	0,257	
Standard deviation of repeatability, s_r , mmol/100 g fat	0,031	0,018	0,043	0,019	0,021	0,010	0,026
Repeatability limit, $r (= 2,8s_r)$, mmol/100 g fat	0,086	0,051	0,118	0,052	0,058	0,028	0,072
Standard deviation, s , mmol/100 g fat	0,064	0,037	0,062	0,004	0,011	0,036	

Bibliography

- [1] ISO 707|IDF 50, *Milk and milk products — Guidance on sampling*
- [2] ISO 1042, *Laboratory glassware — One-mark volumetric flasks*
- [3] ISO 3432|IDF 221, *Cheese — Determination of fat content — Butyrometer for van Gulik method*
- [4] ISO 5725-1, *Accuracy (trueness and precision) of measurement methods and results — Part 1: General principles and definitions*
- [5] ISO 5725-2, *Accuracy (trueness and precision) of measurement methods and results — Part 2: Basic method for the determination of repeatability and reproducibility of a standard measurement method*
- [6] CARTIER, P., CHILLIARD, Y., CHAZAL, M.P. Dosage de l'activité lipasique et des acides gras libres du lait par titration automatique colorimétrique [Determination of milk lipase activity and milk free fatty acid content using colorimetric automatic titration]. *Lait* 1984, **64**, pp. 340–355
- [7] DRIESSEN, F.M., JELLEMA, A., VAN LUIN, F.J.P., STADHOUDERS, J., WOLBERS, G.J.M. The estimation of the fat acidity in raw milk. An adaptation of the BDI method, suitable for routine assays. *Neth. Milk Dairy J.* 1977, **31**, pp. 40–55
- [8] EVERS, J.M., LUCKMAN, S., PALFREYMAN, K.R. The BDI method — Part 1: Determination of free fatty acids in cream and whole milk powder. *Austral. J. Dairy Technol.* 2000, **55**, pp. 33–36
- [9] EVERS, J.M. Determination of free fatty acids in milk using the BDI method — Some practical and theoretical aspects. *Int. Dairy J.* 2003, **13**, pp. 111–121
- [10] JELLEMA, A. *Automatische titratie met behulp van een colorimeter bij the bepaling van de zuurtegraad van het vet. Verslag van een oriënterend onderzoek* [Automatic titration with the aid of a colorimeter in the determination of the degree of fat acidity. Report of an exploratory study]. MOC in Wageningen, in cooperation with Instrument Trading "South Holland" v/h A. Höfelt BV in The Hague, 1979-11
- [11] JELLEMA, A., OGER, R., VAN REUSEL, A. Milk fat products and butter — Determination of fat acidity. Collaborative study by Joint IDF/ISO/AOAC Group E39. *Bull. IDF* 1988, (235), pp. 81–91
- [12] KUZDZAL-SAVOIE, S. Determination of free fatty acids in milk and milk products. *Bull. IDF* 1980, (118), pp. 53–66
- [13] PERRIN, D.R., PERRIN, D.D. The determination of free fatty acids in milk. *J. Dairy Res.* 1958, **25**, pp. 221–227
- [14] *Standard methods for the examination of dairy products*, 17th edition. New York, NY: American Public Health Association, 2004
- [15] VAN REUSEL, A. *Contribution à l'étude de la détermination des acides gras libres dans le lait et les produits laitiers*. [Contribution to the study of the determination of free fatty acids in milk and dairy products]. Gembloux: Centre de Recherches Agronomiques de l'Etat, 1989. (Mémoire n° 12.)

ICS 67.100.10

Price based on 14 pages