

First edition
2003-03-15

**Road vehicles — Drawbar couplings,
drawbar eyes, fifth wheel kingpins, hook
couplings and toroidal eyes — Wear
limits for in-use mechanical couplings**

*Véhicules routiers — Chapes d'attelage, anneaux de remorquage,
pivots d'attelage, attelages à crochet et anneaux de timon toriques —
Limites d'usure pour les dispositifs d'attelage mécaniques en service*



Reference number
ISO/TS 20825:2003(E)

© ISO 2003

PDF disclaimer

This PDF file may contain embedded typefaces. In accordance with Adobe's licensing policy, this file may be printed or viewed but shall not be edited unless the typefaces which are embedded are licensed to and installed on the computer performing the editing. In downloading this file, parties accept therein the responsibility of not infringing Adobe's licensing policy. The ISO Central Secretariat accepts no liability in this area.

Adobe is a trademark of Adobe Systems Incorporated.

Details of the software products used to create this PDF file can be found in the General Info relative to the file; the PDF-creation parameters were optimized for printing. Every care has been taken to ensure that the file is suitable for use by ISO member bodies. In the unlikely event that a problem relating to it is found, please inform the Central Secretariat at the address given below.

© ISO 2003

All rights reserved. Unless otherwise specified, no part of this publication may be reproduced or utilized in any form or by any means, electronic or mechanical, including photocopying and microfilm, without permission in writing from either ISO at the address below or ISO's member body in the country of the requester.

ISO copyright office
Case postale 56 • CH-1211 Geneva 20
Tel. + 41 22 749 01 11
Fax + 41 22 749 09 47
E-mail copyright@iso.org
Web www.iso.org

Published in Switzerland

Contents

Page

Foreword	iv
Introduction	v
1 Scope	1
2 Normative references	1
3 Checking worn components	2
3.1 40 mm and 50 mm drawbar couplings	2
3.2 40 mm and 50 mm drawbar eyes	2
3.3 50 mm and 90 mm fifth wheel kingpins	4
3.4 Hook couplings	4
3.5 Toroidal eyes	4
4 Limit dimensions for worn components	5
4.1 40 mm drawbar couplings and eyes	5
4.2 50 mm drawbar couplings and eyes	6
4.3 50 mm fifth wheel kingpins	6
4.4 90 mm fifth wheel kingpins	7
4.5 Hook couplings and toroidal eyes	7

.....

Foreword

ISO (the International Organization for Standardization) is a worldwide federation of national standards bodies (ISO member bodies). The work of preparing International Standards is normally carried out through ISO technical committees. Each member body interested in a subject for which a technical committee has been established has the right to be represented on that committee. International organizations, governmental and non-governmental, in liaison with ISO, also take part in the work. ISO collaborates closely with the International Electrotechnical Commission (IEC) on all matters of electrotechnical standardization.

International Standards are drafted in accordance with the rules given in the ISO/IEC Directives, Part 2.

The main task of technical committees is to prepare International Standards. Draft International Standards adopted by the technical committees are circulated to the member bodies for voting. Publication as an International Standard requires approval by at least 75 % of the member bodies casting a vote.

In other circumstances, particularly when there is an urgent market requirement for such documents, a technical committee may decide to publish other types of normative document:

- an ISO Publicly Available Specification (ISO/PAS) represents an agreement between technical experts in an ISO working group and is accepted for publication if it is approved by more than 50 % of the members of the parent committee casting a vote;
- an ISO Technical Specification (ISO/TS) represents an agreement between the members of a technical committee and is accepted for publication if it is approved by 2/3 of the members of the committee casting a vote.

An ISO/PAS or ISO/TS is reviewed after three years in order to decide whether it will be confirmed for a further three years, revised to become an International Standard, or withdrawn. If the ISO/PAS or ISO/TS is confirmed, it is reviewed again after a further three years, at which time it must either be transformed into an International Standard or be withdrawn.

Attention is drawn to the possibility that some of the elements of this document may be the subject of patent rights. ISO shall not be held responsible for identifying any or all such patent rights.

ISO/TS 20825 was prepared by Technical Committee ISO/TC 22, *Road vehicles*, Subcommittee SC 15, *Interchangeability of components of commercial vehicles and buses*.

Introduction

This Technical Specification is intended to provide limits to the wear of standardized mechanical couplings mounted on heavy commercial vehicles, in order to ensure their safe on-road operation.

This Technical Specification has been considered necessary because the lack of any compulsory requirement applicable to the allowable wear of mechanical couplings has meant that the competent authorities, when checking in-use vehicles, make reference only to the design dimensions of standardized mechanical couplings. Nor have they been taking into consideration the wear limits indicated by each mechanical coupling manufacturer on the instructions for use and maintenance of the coupling.

This Technical Specification is addressed to all parties involved in the safe use of heavy commercial vehicles, i.e. the owner, any competent person who conducts the periodical maintenance and the competent authorities conducting the periodical inspection and check of in-use vehicles.

© 2005 International Organization for Standardization

Road vehicles — Drawbar couplings, drawbar eyes, fifth wheel kingpins, hook couplings and toroidal eyes — Wear limits for in-use mechanical couplings

1 Scope

This Technical Specification specifies the maximum allowable wear and the limit dimensions of worn components of in-use mechanical couplings, which, when respected, will ensure the safe operation on the road of heavy commercial vehicles fitted with such couplings.

It is applicable to the following standardized mechanical couplings:

- 40 mm and 50 mm drawbar couplings (see ISO 3584);
- 40 mm and 50 mm drawbar eyes (see ISO 8755 and ISO 1102);
- 50 mm and 90 mm fifth wheel kingpins (see ISO 337 and ISO 4086);
- hook couplings and toroidal eyes (see ECE Regulation No. 55).

2 Normative references

The following referenced documents are indispensable for the application of this document. For dated references, only the edition cited applies. For undated references, the latest edition of the referenced document (including any amendments) applies.

ISO 337:1981, *Road vehicles — 50 semi-trailer fifth wheel coupling pin — Basic and mounting/interchangeability dimensions*

ISO 1102:2001, *Commercial road vehicles — 50 mm drawbar eye — Interchangeability*

ISO 3584:2001, *Road vehicles — Drawbar couplings — Interchangeability*

ISO 4086:2001, *Road vehicles — 90 semi-trailer fifth wheel kingpin — Interchangeability*

ISO 8755:2001, *Commercial road vehicles — 40 mm drawbar eye — Interchangeability*

ECE Regulation No. 55, Revision 1:2001, *Uniform Provisions Concerning the Approval of Mechanical Coupling Components of Combinations of Vehicles*

3 Checking worn components

3.1 40 mm and 50 mm drawbar couplings

3.1.1 During normal operation, mechanical contact between the drawbar coupling pin and the drawbar eye bush generates wear of the pin surface. It is generally noted that this results in an elliptical section of the pin on the horizontal symmetry plane, the minimum dimension being in the longitudinal axis direction (Figure 1 shows the dimension to be checked).

3.1.2 Check worn coupling pins either by direct measurement or using special gauges.

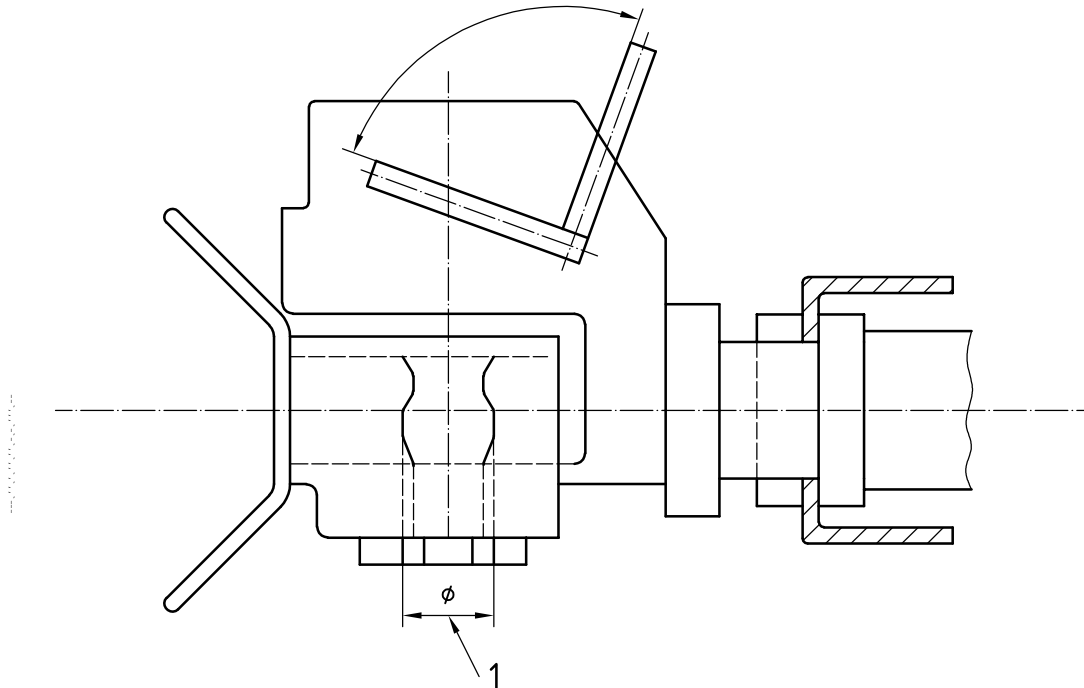

Key

1 dimension to be checked

Figure 1 — Dimension to be checked on 40 mm and 50 mm drawbar couplings

3.2 40 mm and 50 mm drawbar eyes

3.2.1 During normal operation, mechanical contact between the drawbar eye bush and the drawbar coupling pin generates wear of the bush surface. It is generally noted that this results in an elliptical section of the bush on the horizontal symmetry plane, the maximum dimension being in the longitudinal axis direction (Figures 2 and 3 show the dimension to be checked).

3.2.2 During normal operation, mechanical contact between the drawbar eye and the drawbar coupling jaw generates wear of the upper and lower surfaces of the drawbar eye. It is generally noted that this results in a reduced drawbar eye thickness on both sides of the eye centre. This may lead to the sleeve moving away from its normal working position (Figures 2 and 3 show the dimension to be checked).

3.2.3 Check worn drawbar eyes either by direct measurement or using special gauges.

3.2.4 Check the thickness of drawbar eyes on each side of the longitudinal median plane.

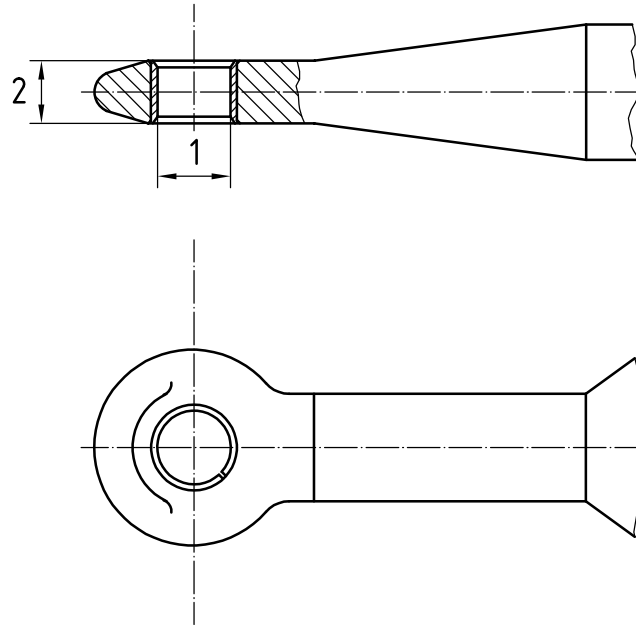

Key

- 1 dimension to be checked, eye bush
- 2 dimension to be checked, thickness

Figure 2 — Dimensions to be checked on 40 mm drawbar eyes

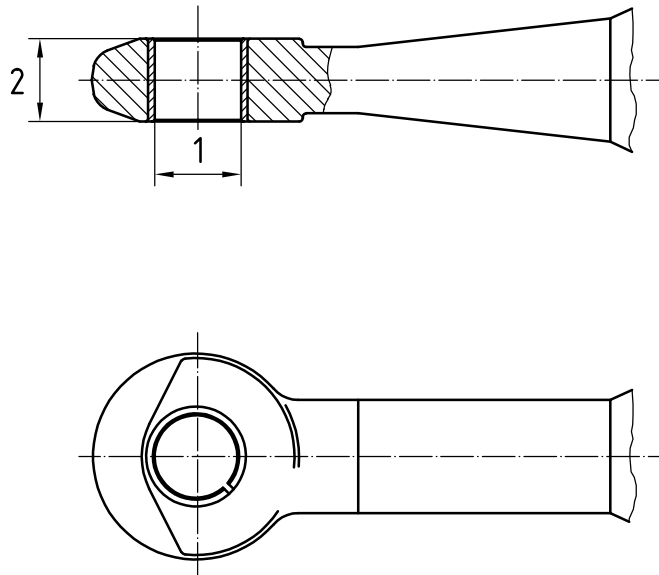

Key

- 1 dimension to be checked, eye bush
- 2 dimension to be checked, thickness

Figure 3 — Dimensions to be checked on 50 mm drawbar eyes

3.3 50 mm and 90 mm fifth wheel kingpins

3.3.1 During normal operation, mechanical contact between the kingpin and the fifth wheel locking jaw generates wear of the kingpin. It is generally noted that this results in an elliptical section of the kingpin, in its two upper cylinders, on the horizontal symmetry plane, the minimum dimensions being in the longitudinal axis direction (Figure 4 shows the dimensions to be checked).

3.3.2 Check worn kingpins either by direct measurement or using special gauges.

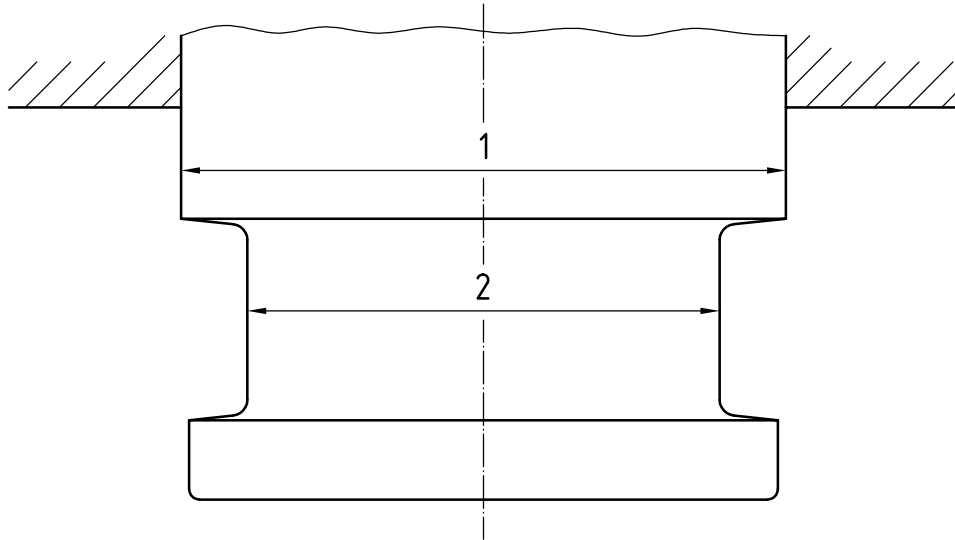

Key

- 1 dimension to be checked, upper diameter
- 2 dimension to be checked, inner diameter

Figure 4 — Dimensions to be checked on 50 mm and 90 mm fifth wheel kingpins

3.4 Hook couplings

3.4.1 During normal operation, mechanical contact between the hook coupling and the toroidal eye generates wear of the inner surface of the hook. It is generally noted that this results in a widening of the inner clearance in the longitudinal axis direction (Figure 5 shows the dimension to be checked).

3.4.2 Check worn hook couplings either by direct measurement or using special gauges.

3.5 Toroidal eyes

3.5.1 During normal operation, mechanical contact between the toroidal eye and the hook coupling generates wear of the torus at the foremost extremity of the eye. It is generally noted that this results in a minimum thickness of the torus that does not necessarily have to be in the horizontal or vertical axis direction (Figure 6 shows the dimension to be checked).

3.5.2 Check worn toroidal eyes either by direct measurement or using special gauges.

3.5.3 Check the thickness of the foremost extremity of the torus at the weakest spot of the torus section, which may be measured in any axis direction of the torus.

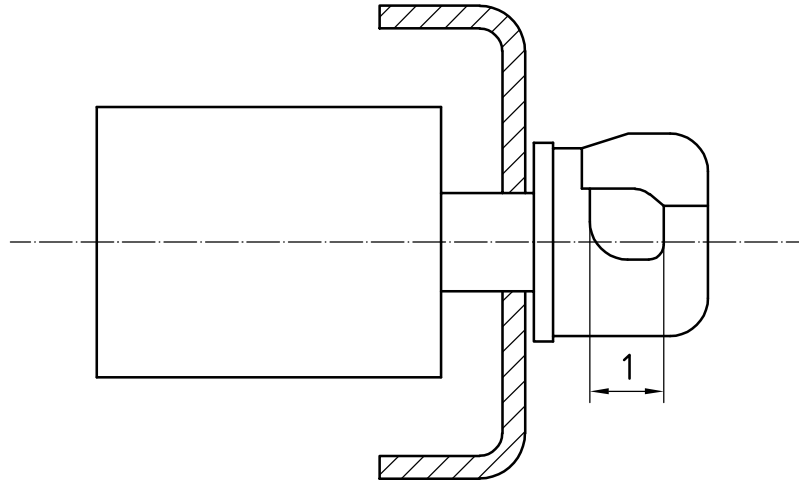

Key

- 1 dimension to be checked

Figure 5 — Dimension to be checked on hook couplings

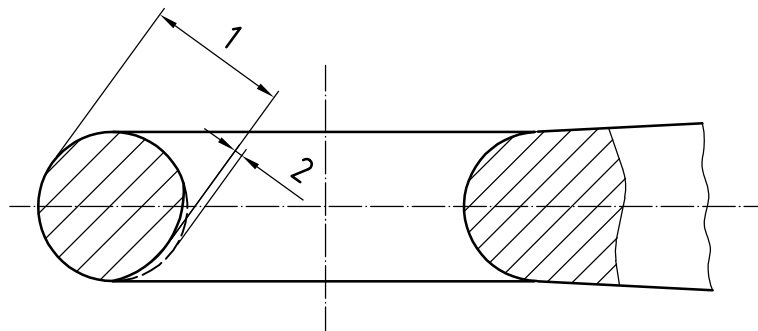

Key

- 1 dimension to be checked
- 2 wear

Figure 6 — Dimension to be checked on toroidal eyes

4 Limit dimensions for worn components

4.1 40 mm drawbar couplings and eyes

Limit dimensions for worn 40 mm drawbar couplings and eyes, checked in accordance with 3.1 and 3.2, are given in Table 1.

Table 1 — Limit dimensions for worn 40 mm drawbar couplings and eyes

Dimensions in millimetres

Mechanical coupling	In-use limit dimension
40 mm drawbar coupling pin ^a	$\geq 36,5$
40 mm drawbar eye bush ^b	$\leq 41,5$
40 mm drawbar eye thickness ^c	≥ 28
^a Outer diameter of the pin: standard design dimension is as shown in ISO 3584:2001, Figure 7, side view. ^b Inner diameter of the bush: standard design dimension is as shown in ISO 8755:2001, Figures 2 and 3. ^c Thickness of the eye: standard design dimension is as shown in ISO 8755:2001, Figure 1, Section C-A.	

4.2 50 mm drawbar couplings and eyes

Limit dimensions for worn 50 mm drawbar couplings and eyes, checked in accordance with 3.1 and 3.2, are given in Table 2.

Table 2 — Limit dimensions for worn 50 mm drawbar couplings and eyes

Dimensions in millimetres

Mechanical coupling	In-use limit dimension
50 mm drawbar coupling pin ^a	$\geq 46,5$
50 mm drawbar eye bush ^b	$\leq 51,5$
50 mm drawbar eye thickness ^c	$\geq 41,5$
^a Outer diameter of the pin: standard design dimension is as shown in ISO 3584:2001, Figure 7, side view. ^b Inner diameter of the bush: standard design dimension is as shown in ISO 1102:2001, Figures 2 and 3. ^c Thickness of the eye: standard design dimension is as shown in ISO 1102:2001, Figure 1, side view.	

4.3 50 mm fifth wheel kingpins

Limit dimensions for worn 50 mm fifth wheel kingpins, checked in accordance with 3.3, are given in Table 3.

Table 3 — Limit dimensions for worn 50 mm fifth wheel kingpins

Dimensions in millimetres

Mechanical coupling	In-use limit dimension
50 mm fifth wheel kingpin, upper cylinder ^a	≥ 71
50 mm fifth wheel kingpin, median cylinder ^b	≥ 49
^a Outer diameter of the upper cylinder: standard design dimension is as shown in ISO 337:1981, Figure 1. ^b Outer diameter of the median cylinder: standard design dimension is as shown in ISO 337:1981, Figure 1.	

4.4 90 mm fifth wheel kingpins

Limit dimensions for worn 90 mm fifth wheel kingpins, checked in accordance with 3.3, are given in Table 4.

Table 4 — Limit dimensions for worn 90 mm fifth wheel kingpins

Dimensions in millimetres

Mechanical coupling	In-use limit dimension
90 mm fifth wheel kingpin, upper cylinder ^a	≥ 112
90 mm fifth wheel kingpin, median cylinder ^b	≥ 86
^a Outer diameter of the upper cylinder: standard design dimension is as shown in ISO 4086, Figure 1. ^b Outer diameter of the median cylinder: standard design dimension is as shown in ISO 4086, Figure 1.	

4.5 Hook couplings and toroidal eyes

Limit dimensions for worn 68 mm and 76 mm toroidal eyes, and the relevant hook couplings, checked in accordance with 3.4 and 3.5, are given in Table 5.

Table 5 — Limit dimensions for worn hook couplings and toroidal eyes

Dimensions in millimetres

Mechanical coupling	In-use limit dimension
hook coupling ^a	≤ 49
68 mm and 76 mm toroidal eye ^b	≥ 37
^a Inner longitudinal clearance of the hook: standard design dimension is as shown in Regulation No. 55, Revision 1, Figure 19. ^b Outer diameter of the torus: standard design dimension is as shown in Regulation ECE:2001 No. 55, Revision 1, Figure 14.	

1

ICS 43.040.70

Price based on 7 pages