

INTERNATIONAL STANDARD

ISO 19956

First edition
2004-09-15

Footwear — Test methods for heels — Fatigue resistance

*Chaussures — Méthodes d'essai relatives aux talons — Résistance à
la fatigue*



Reference number
ISO 19956:2004(E)

© ISO 2004

PDF disclaimer

This PDF file may contain embedded typefaces. In accordance with Adobe's licensing policy, this file may be printed or viewed but shall not be edited unless the typefaces which are embedded are licensed to and installed on the computer performing the editing. In downloading this file, parties accept therein the responsibility of not infringing Adobe's licensing policy. The ISO Central Secretariat accepts no liability in this area.

Adobe is a trademark of Adobe Systems Incorporated.

Details of the software products used to create this PDF file can be found in the General Info relative to the file; the PDF-creation parameters were optimized for printing. Every care has been taken to ensure that the file is suitable for use by ISO member bodies. In the unlikely event that a problem relating to it is found, please inform the Central Secretariat at the address given below.

© ISO 2004

All rights reserved. Unless otherwise specified, no part of this publication may be reproduced or utilized in any form or by any means, electronic or mechanical, including photocopying and microfilm, without permission in writing from either ISO at the address below or ISO's member body in the country of the requester.

ISO copyright office
Case postale 56 • CH-1211 Geneva 20
Tel. + 41 22 749 01 11
Fax + 41 22 749 09 47
E-mail copyright@iso.org
Web www.iso.org

Published in Switzerland

Foreword

ISO (the International Organization for Standardization) is a worldwide federation of national standards bodies (ISO member bodies). The work of preparing International Standards is normally carried out through ISO technical committees. Each member body interested in a subject for which a technical committee has been established has the right to be represented on that committee. International organizations, governmental and non-governmental, in liaison with ISO, also take part in the work. ISO collaborates closely with the International Electrotechnical Commission (IEC) on all matters of electrotechnical standardization.

International Standards are drafted in accordance with the rules given in the ISO/IEC Directives, Part 2.

The main task of technical committees is to prepare International Standards. Draft International Standards adopted by the technical committees are circulated to the member bodies for voting. Publication as an International Standard requires approval by at least 75 % of the member bodies casting a vote.

Attention is drawn to the possibility that some of the elements of this document may be the subject of patent rights. ISO shall not be held responsible for identifying any or all such patent rights.

ISO 19956 was prepared by the European Committee for Standardization (CEN) in collaboration with Technical Committee ISO/TC 216, *Footwear*, in accordance with the Agreement on technical cooperation between ISO and CEN (Vienna Agreement).

Throughout the text of this document, read “...this European Standard...” to mean “...this International Standard...”.

Contents

page

Foreword.....	v
1 Scope	1
2 Terms and definitions	1
3 Apparatus and material	1
4 Sampling and conditioning.....	3
5 Test method.....	3
6 Expression of results	4
7 Test report	4

Foreword

This document (EN ISO 19956:2004) has been prepared by Technical Committee CEN /TC 309 "Footwear", the secretariat of which is held by AENOR, in collaboration with Technical Committee ISO/TC 216 "Footwear".

This European Standard shall be given the status of a national standard, either by publication of an identical text or by endorsement, at the latest by March 2005, and conflicting national standards shall be withdrawn at the latest by March 2005.

According to the CEN/CENELEC Internal Regulations, the national standards organizations of the following countries are bound to implement this European Standard: Austria, Belgium, Cyprus, Czech Republic, Denmark, Estonia, Finland, France, Germany, Greece, Hungary, Iceland, Ireland, Italy, Latvia, Lithuania, Luxembourg, Malta, Netherlands, Norway, Poland, Portugal, Slovakia, Slovenia, Spain, Sweden, Switzerland and United Kingdom.

1 Scope

This European Standard specifies a test method for determining the ability of heels of ladies' shoes to withstand the repeated small impacts imposed by normal walking. Although intended primarily for plastics heels, the procedure is also usable for testing steel heel dowels on their own.

NOTE While the test method is applicable to all types of high heels of any construction, it is particularly useful for injection-moulded plastics heels which incorporate a steel dowel reinforcement. The shape of some heels is such that they have a high fatigue resistance. It is usually considered unnecessary to test such heels for fatigue resistance.

2 Terms and definitions

For the purposes of this European Standard, the following term and definition apply.

fatigue resistance

resistance of a heel, under specified conditions, to repeated loading cycles.

3 Apparatus and material

3.1 The following apparatus and material shall be used:

3.2 Heel fatigue-testing apparatus, incorporating a motor-driven pendulum which can deliver blows to a test specimen assembly, each blow having an energy of 0,68 J, at the rate of one blow per second. The apparatus is clamped either on to a solid built-in bench, or on to a rigid free-standing frame anchored to the floor (see NOTE). An example of a suitable apparatus is shown in Figure 1.

NOTE If the apparatus is not firmly mounted, there is a partial loss of energy on impact, thereby producing false results.

The apparatus shall include the following:

3.2.1 Pendulum, consisting of a circular steel bob of diameter $57 \text{ mm} \pm 1 \text{ mm}$ and thickness $20 \text{ mm} \pm 1 \text{ mm}$, which is fixed by a circular shaft of diameter $12,5 \text{ mm} \pm 1,0 \text{ mm}$ to a hub on the bearing axle. The distance from the centre of the bob to the centre of the hub is $152 \text{ mm} \pm 2 \text{ mm}$. The moment of the pendulum when is held horizontally is $0,68 \text{ N}\cdot\text{m} \pm 0,02 \text{ N}\cdot\text{m}$.

3.2.2 Striker head, consisting of a strip of metal $6,0 \text{ mm} \pm 0,5 \text{ mm}$ thick, $20 \text{ mm} \pm 1 \text{ mm}$ wide and $35 \text{ mm} \pm 2 \text{ mm}$ long with the striking edge rounded to a radius of $3,0 \text{ mm} \pm 0,5 \text{ mm}$. The head is fixed rigidly to the pendulum bob so that the striker tip and centre of the bob lie on the same circle of swing of the pendulum and are $63,5 \text{ mm} \pm 2 \text{ mm}$ apart.

3.2.3 Rebound damper, for the pendulum.

3.2.4 Base clamp, for holding the metal mounting tray (3.3) and for adjusting it vertically and horizontally to achieve correct alignment of the heel tip.

3.2.5 Counter, for recording the number of blows.

3.2.6 Overshoot cut-out device, which operates when the pendulum overshoots a broken heel stem at complete failure.

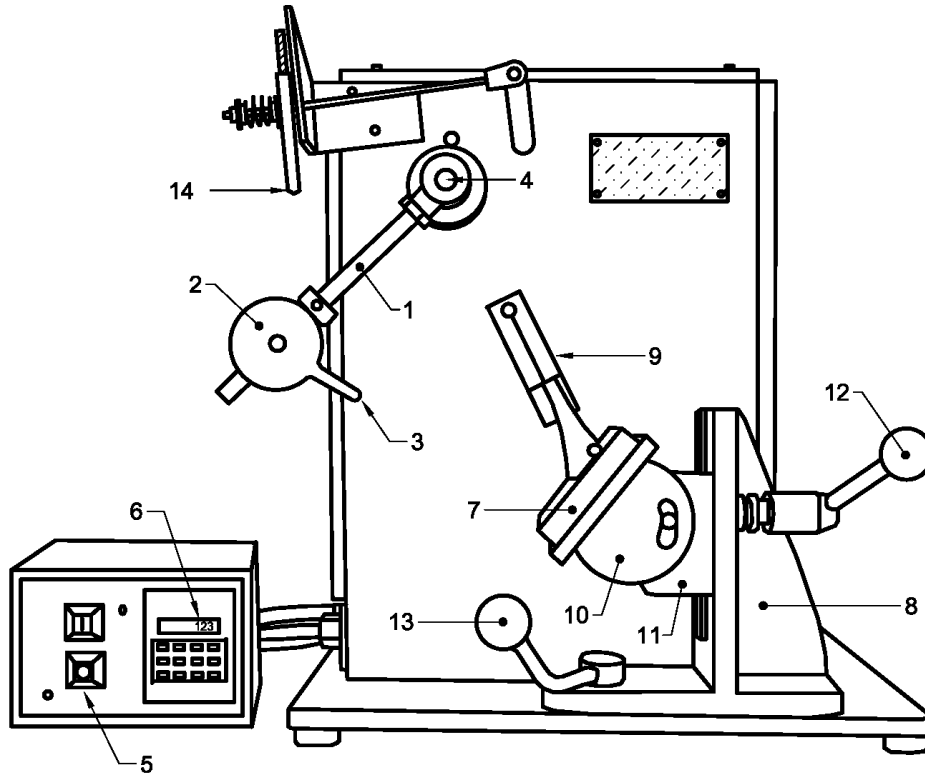

Key

- 1 Pendulum
- 2 Pendulum bob
- 3 Striker head
- 4 Hub
- 5 Power supply switch
- 6 Counter
- 7 Test specimen assembly
- 8 Vertical locking plate
- 9 Sighting plate for aligning the heel
- 10 Base clamp for rotation orientation
- 11 Clamp for vertical orientation
- 12 Device for locking 10 and 11 against 8
- 13 Horizontal locking device
- 14 Rebound damper, for the pendulum

Figure 1 — Heel fatigue-testing apparatus

3.3 Metal mounting trays. An example of a suitable apparatus is shown in Figure 2. Each to contain a heel set in low melting point metal alloy (3.4).

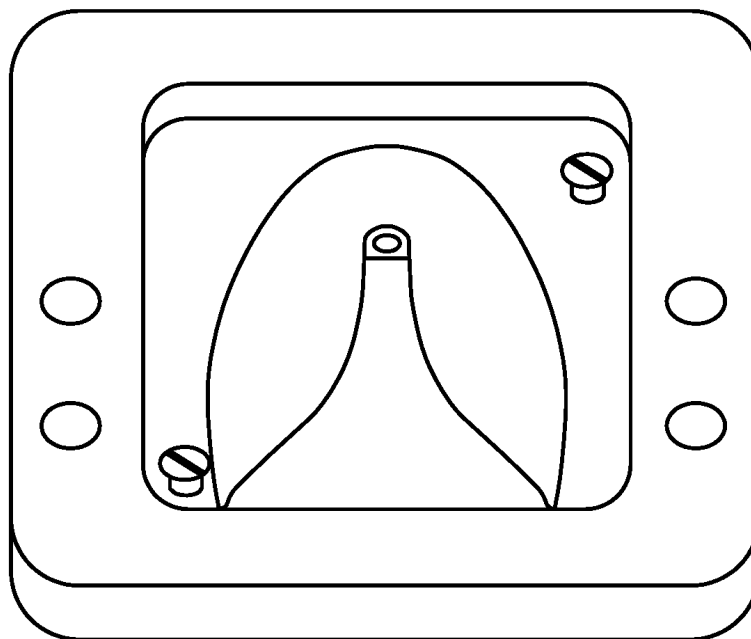

Figure 2 — Metal mounting tray with heel in position before addition of molten metal alloy

3.4 Metal alloy, melting point between 100 °C and 150 °C.

4 Sampling and conditioning

4.1 Take three heels and set each heel in a dry metal mounting tray (3.3), using the procedure described in 4.2, to obtain a test specimen assembly.

4.2 Place the heel centrally in the tray so that the seat breast edge is against a flat end of the tray and heel tip points upwards (see Figure 2). Heat the metal alloy (3.4) until it is at the lowest temperature at which it will flow into all parts of the tray. Pour it into the tray filling the space around the heel to within 3 mm from the top of the tray. Allow the metal alloy to cool and set, thereby providing a rigid mounting for the heel.

5 Test method

5.1 Principle

A heel is subjected to blows, each of specified energy, delivered by a pendulum once a second. Testing continues until failure of the heel takes place, or until satisfactory fatigue resistance is obvious.

5.2 Procedure

5.2.1 With the pendulum in the rest position, insert the test specimen assembly in the inclined part of the base clamp (3.2.4) of the heel fatigue-testing apparatus (3.2) with the back of the heel facing the pendulum. Set the test specimen assembly at suitable angle to the horizontal so that the blow will be applied approximately at right angles to the heel stem.

Adjust the position of the test specimen assembly in the base clamp until the striker (3.2.2) barely contacts the heel 6 mm below the heel tip. Set the counter (3.2.5) to “zero” (or note the riding), and start the machine ensuring that the overshoot cut-out device is activated.

5.2.2 At intervals of 60 min check whether any damage has developed that still allows the pendulum to continue in motion. If it has, record the number of blows shown by the machine counter and describe the type of damage.

5.2.3 If damage develops and becomes so severe that the overshoot cut-out device stops the machine (termed “complete failure”), record the number of blows and describe the type of damage.

5.2.4 If a complete failure is not occurred after 20 000 blows (approximately 5 h 30 min) discontinue the test and describe any damage that has developed.

5.2.5 Damage involving fracture or cracking of the heel at the point of impact of the striker is regarded as invalid in this test, since it is due to the effect of the striker acting as a chisel rather than fracture of the heel due to impact at the heel as in wear. If such damage occurs, report it together with this explanation.

5.2.6 Repeat the test with the other two test specimen assemblies by following the same procedure.

6 Expression of results

Express the result for each test specimen assembly in one or more of the following ways, as appropriate:

- a) the number of blows at which damage was first detected, as described in 5.2.2;
- b) the number of blows at which complete failure occurred, as described in 5.2.3;
- c) the fact that no complete failure occurred within 20 000 blows, as described in 5.2.4;
- d) the fact that damage involving fracture or cracking of the heel at the point of impact occurred, as described in 5.2.5.

7 Test report

The test report shall include the following information:

- a) the result for each heel, expressed in accordance with clause 6;
- b) description of the damage or completely failure corresponding to test results expressed according to 6 a), 6 b), 6 c) and/or 6 d), as applicable;
- c) a full description of the samples tested, including commercial styles codes, colours, nature, etc.;
- d) reference of this method of test;
- e) date of testing;
- f) any deviation from this test method.

ICS 61.060

Price based on 4 pages