

---

---

**Road vehicles — M10 × 1 compact  
spark-plugs with flat seating and 16 mm  
hexagon and their cylinder head  
 housings**

*Véhicules routiers — Bougies d'allumage M10 × 1 «compactes» à siège  
plat et à hexagone de 16 mm et leurs logements dans la culasse*



**PDF disclaimer**

This PDF file may contain embedded typefaces. In accordance with Adobe's licensing policy, this file may be printed or viewed but shall not be edited unless the typefaces which are embedded are licensed to and installed on the computer performing the editing. In downloading this file, parties accept therein the responsibility of not infringing Adobe's licensing policy. The ISO Central Secretariat accepts no liability in this area.

Adobe is a trademark of Adobe Systems Incorporated.

Details of the software products used to create this PDF file can be found in the General Info relative to the file; the PDF-creation parameters were optimized for printing. Every care has been taken to ensure that the file is suitable for use by ISO member bodies. In the unlikely event that a problem relating to it is found, please inform the Central Secretariat at the address given below.

© ISO 2006

All rights reserved. Unless otherwise specified, no part of this publication may be reproduced or utilized in any form or by any means, electronic or mechanical, including photocopying and microfilm, without permission in writing from either ISO at the address below or ISO's member body in the country of the requester.

ISO copyright office  
Case postale 56 • CH-1211 Geneva 20  
Tel. + 41 22 749 01 11  
Fax + 41 22 749 09 47  
E-mail [copyright@iso.org](mailto:copyright@iso.org)  
Web [www.iso.org](http://www.iso.org)

Published in Switzerland

## Foreword

ISO (the International Organization for Standardization) is a worldwide federation of national standards bodies (ISO member bodies). The work of preparing International Standards is normally carried out through ISO technical committees. Each member body interested in a subject for which a technical committee has been established has the right to be represented on that committee. International organizations, governmental and non-governmental, in liaison with ISO, also take part in the work. ISO collaborates closely with the International Electrotechnical Commission (IEC) on all matters of electrotechnical standardization.

International Standards are drafted in accordance with the rules given in the ISO/IEC Directives, Part 2.

The main task of technical committees is to prepare International Standards. Draft International Standards adopted by the technical committees are circulated to the member bodies for voting. Publication as an International Standard requires approval by at least 75 % of the member bodies casting a vote.

Attention is drawn to the possibility that some of the elements of this document may be the subject of patent rights. ISO shall not be held responsible for identifying any or all such patent rights.

ISO 19812 was prepared by Technical Committee ISO/TC 22, *Road vehicles*, Subcommittee SC 1, *Ignition equipment*.

.....

# Road vehicles — M10 × 1 compact spark-plugs with flat seating and 16 mm hexagon and their cylinder head housings

## 1 Scope

This International Standard specifies characteristics of M10 × 1 compact spark-plugs with flat seating and 16 mm hexagon, and of their cylinder head housing, for use with spark-ignition engines.

## 2 Normative references

The following referenced documents are indispensable for the application of this document. For dated references, only the edition cited applies. For undated references, the latest edition of the referenced document (including any amendments) applies.

ISO 68-1, *ISO general purpose screw threads — Basic profile — Part 1: Metric screw threads*

ISO 261, *ISO general purpose metric screw threads — General plan*

ISO 965-1, *ISO general-purpose metric screw threads — Tolerances — Part 1: Principles and basic data*

ISO 965-3, *ISO general purpose metric screw threads — Tolerances — Part 3: Deviations for constructional screw threads*

ISO 14508, *Road vehicles — Spark-plugs — Terminals*

## 3 Terminals

The spark-plug terminal may be either the solid post or the threaded type as described in ISO 14508. A spark-plug with threaded terminal on which a nut is applied shall respect the dimensions specified for spark-plugs with solid post terminals (see Figures 1 and 2).

## 4 Dimensions and threads

### 4.1 Spark-plug reach

Spark-plug reach shall be according to Table 1.

Table 1 — Spark-plug reach

Dimensions in millimetres

Type of reach	<i>A</i> ± 0,2	<i>B</i> max.	<i>Y</i> + 0,3 – 0,8
Short	9,5	16	9
Normal	12,7	19	11,7

## 4.2 Gasket

When the spark-plugs have been tightened with a torque of 15 N · m, on threads that are clean, smooth and dry, the gaskets shall be 1 mm to 1,6 mm thick. If the gasket thicknesses are different, a corresponding adjustment to dimensions *A*, *B* and *Y* shall be made.

Non-captive gaskets may be used in special cases.

## 4.3 Threads for spark-plugs and cylinder heads

### 4.3.1 General

The threads of M10 × 1 spark-plugs and the corresponding tapped holes in the cylinder head shall conform to ISO 68-1, ISO 261, ISO 965-1 and ISO 965-3. Their limiting dimensions and their tolerance classes are specified in 4.3.2 and 4.3.3 respectively.

### 4.3.2 Limiting dimensions

The limiting dimensions are given in Table 2.

Table 2 — Limiting dimensions

Dimensions in millimetres

Dimension		Plug thread (on finished plug)	Tapped hole in cylinder head
Major diameter	max.	9,974	Not specified
	min.	9,794	10
Pitch diameter	max.	9,324	9,50
	min.	9,212	9,35
Minor diameter	max.	8,747	9,153
	min.	8,563 <sup>a</sup>	8,917

<sup>a</sup> With a root radius  $\geq 0,1$  mm (0,1 *P*).

### 4.3.3 Tolerance classes

The thread tolerance classes of finished M10 × 1 compact spark-plugs and of the corresponding tapped holes in the cylinder head are:

- 6g for spark-plugs (see Note 1);
- 6H for tapped holes in the cylinder head.

NOTE 1 In order that spark-plugs complying with this International Standard can be fitted in existing cylinder heads also in extreme cases, the value for the maximum truncation of the minor diameter of the spark-plug base has been slightly reduced with respect to the ISO value. This maximum value of the minor diameter is calculated from a distance of  $H/6$  for the maximum truncation instead of the value given by the formula in ISO 965-1:1998, Clause 11, according to the formula given below:

$$\begin{aligned} \text{Minor diameter, maximum} &= d_1 - es - 2(H/4 - H/6) \\ &= (8,917 - 0,026 - 0,144) \text{ mm} \\ &= (8,917 - 0,170) \text{ mm} = 8,747 \text{ mm} \end{aligned}$$

The value for the basic profile remains the same as for the ISO thread  $(8,917 - 0,026) \text{ mm} = 8,891 \text{ mm}$ .

NOTE 2 The initial clearance  $e = 0,026 \text{ mm}$  between the pitch diameters of the thread and of the tapped hole is intended to prevent the possibility of seizure, as a result of combustion deposits on the bare threads, when removing the spark-plugs. This clearance is also intended to enable spark-plugs with threads in accordance with this International Standard to be fitted in existing tapped holes.

## 5 Other dimensions of spark-plugs and their cylinder head housings

The other dimensions shall be as indicated in Figures 1 to 5.

The contour of the insulator is optional; however, between the reference planes defined for spark-plugs with solid post terminal and ribbed insulator by the dimensions 17 mm and 21 mm, and for spark-plugs with threaded terminal and ribbed insulator by the dimensions 15,5 mm and 19,5 mm, its largest diameter shall be  $10,5 \text{ mm} \pm 0,3 \text{ mm}$ .

The number and shape of ribs is optional.

The length of the cylinder head housing  $Z$  shall be sufficient to ensure that the end of the spark-plug thread does not project into the combustion chamber at any point when the gasket is tightened to maximum specified torque.

Details not specified are left to the manufacturer's choice.





Dimensions in millimetres

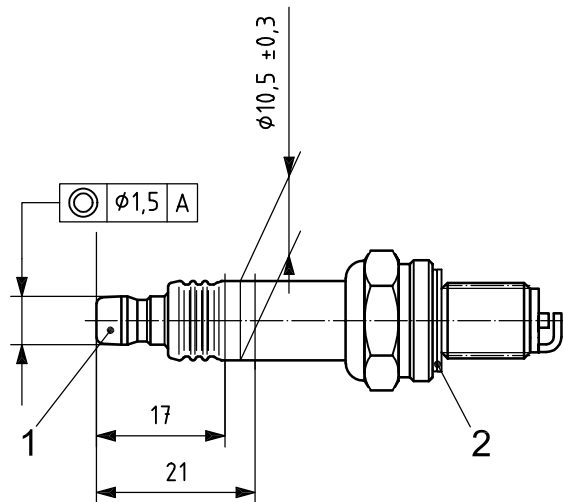

**Key**

- 1 solid post terminal (ISO 14508)
- 2 captive gasket

**Figure 2 — M10 × 1 spark-plug with solid post terminal (traditional design with ribbed insulator)**

Dimensions in millimetres

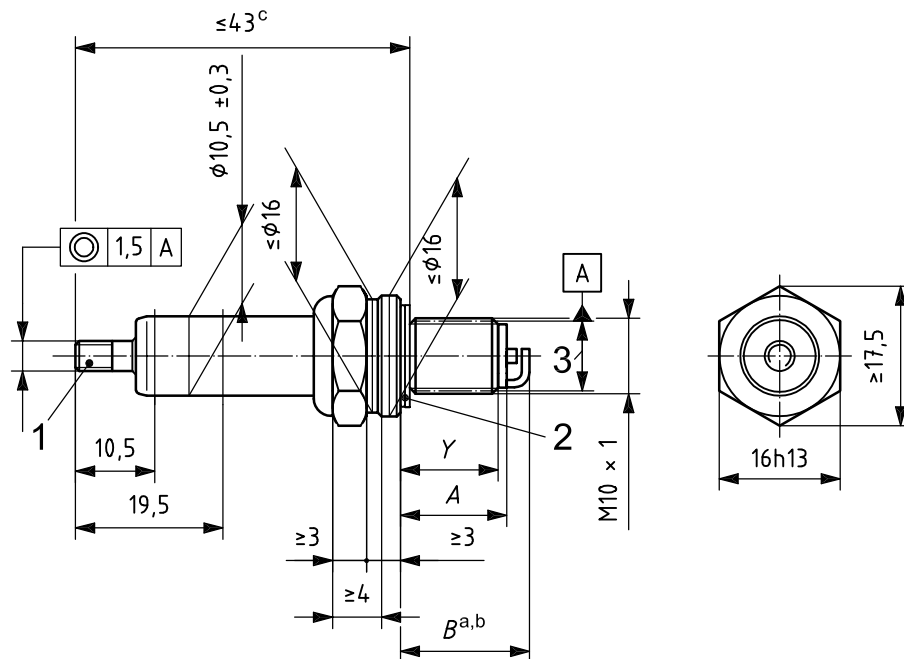

**Key**

- 1 threaded terminal (ISO 14508)
- 2 captive gasket
- 3 pitch diameter

a See Clause 4.

b Dimension B is the maximum protrusion of any part of the spark-plug into the combustion chamber, measured from the spark-plug seat, not including the gasket.

c Dimension after spark-plug has been tightened with a torque of 15 N · m.

**Figure 3 — M10 × 1 spark-plug with threaded terminal (preferred design with non-ribbed insulator)**

Dimensions in millimetres

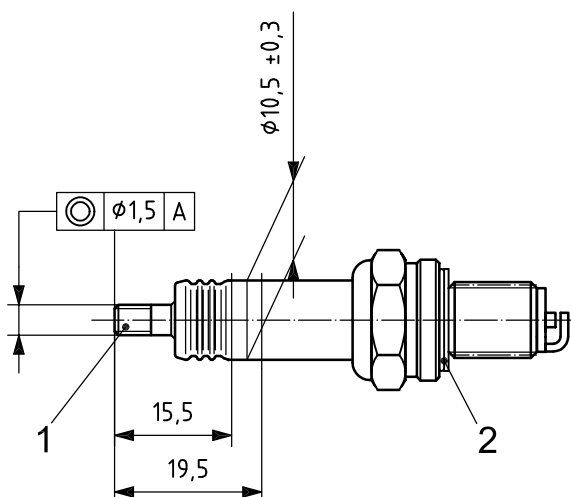

**Key**

- 1 threaded terminal (ISO 14508)
- 2 captive gasket

**Figure 4 — M10 × 1 spark-plug with threaded terminal (traditional design with ribbed insulator)**

Dimensions in millimetres

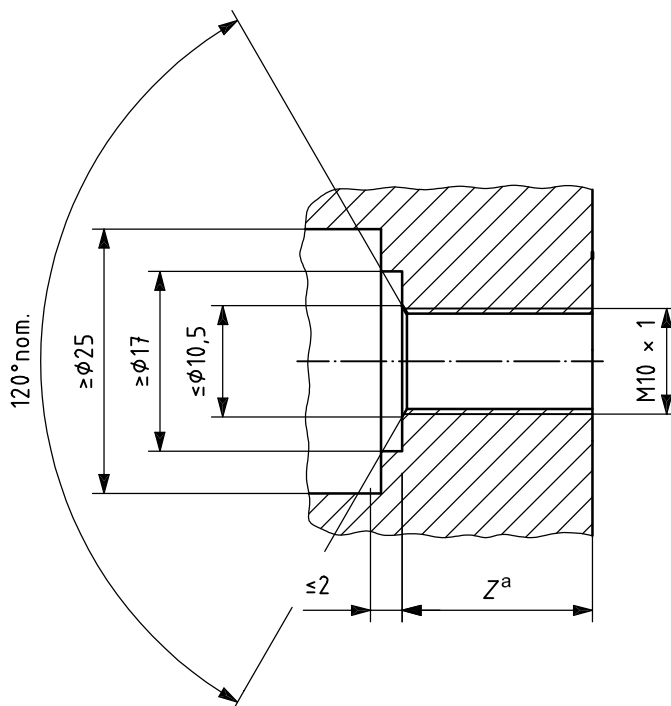

<sup>a</sup> See Clause 5.

**Figure 5 — Cylinder head housing**

## 6 Installation tightening torque

The installation torque values apply to new spark-plugs without lubricant on the threads. If threads are lubricated, the torque value shall be reduced by approximately one-third to avoid overstressing.

Spark-plugs shall be tightened with a torque of 10 N · m to 15 N · m in aluminium alloy and cast iron cylinder heads.

Engine manufacturers may specify a different torque for the first spark-plug installation.

Vertical line of small characters or a barcode-like artifact.

---

---

**ICS 43.060.50**

Price based on 7 pages