**Transport packaging — Small load
container systems —**

Part 1:
**Common requirements and test
methods**

*Emballage de transport — Systèmes de transport de petites
charges —*

Partie 1: Exigences communes et méthodes d'essai





COPYRIGHT PROTECTED DOCUMENT

© ISO 2016, Published in Switzerland

All rights reserved. Unless otherwise specified, no part of this publication may be reproduced or utilized otherwise in any form or by any means, electronic or mechanical, including photocopying, or posting on the internet or an intranet, without prior written permission. Permission can be requested from either ISO at the address below or ISO's member body in the country of the requester.

ISO copyright office
Ch. de Blandonnet 8 • CP 401
CH-1214 Vernier, Geneva, Switzerland
Tel. +41 22 749 01 11
Fax +41 22 749 09 47
copyright@iso.org
www.iso.org

Contents

	Page
Foreword	iv
Introduction	v
1 Scope	1
2 Normative references	1
3 Terms and definitions	1
4 Module capacity	2
5 SLC system elements designation	2
6 Loads	3
7 Requirements	3
7.1 Quality conditions	3
7.2 Stack stability	4
7.3 Base deflection in the condition as delivered	4
8 Material	5
9 Marking and labelling	5
9.1 Marking	5
9.2 Labelling	6
Annex A (normative) Testing	8
Annex B (informative) Applications	15
Annex C (normative) UV stabilization and cleaning	17
Bibliography	18

Foreword

ISO (the International Organization for Standardization) is a worldwide federation of national standards bodies (ISO member bodies). The work of preparing International Standards is normally carried out through ISO technical committees. Each member body interested in a subject for which a technical committee has been established has the right to be represented on that committee. International organizations, governmental and non-governmental, in liaison with ISO, also take part in the work. ISO collaborates closely with the International Electrotechnical Commission (IEC) on all matters of electrotechnical standardization.

The procedures used to develop this document and those intended for its further maintenance are described in the ISO/IEC Directives, Part 1. In particular the different approval criteria needed for the different types of ISO documents should be noted. This document was drafted in accordance with the editorial rules of the ISO/IEC Directives, Part 2 (see www.iso.org/directives).

Attention is drawn to the possibility that some of the elements of this document may be the subject of patent rights. ISO shall not be held responsible for identifying any or all such patent rights. Details of any patent rights identified during the development of the document will be in the Introduction and/or on the ISO list of patent declarations received (see www.iso.org/patents).

Any trade name used in this document is information given for the convenience of users and does not constitute an endorsement.

For an explanation on the meaning of ISO specific terms and expressions related to conformity assessment, as well as information about ISO's adherence to the World Trade Organization (WTO) principles in the Technical Barriers to Trade (TBT) see the following URL: www.iso.org/iso/foreword.html.

The committee responsible for this document is ISO/TC 122, *Packaging*.

A list of all parts in the ISO 19709 series can be found on the ISO website.

Introduction

The exchange of goods between national and international partners is increasingly dependent upon “just-in-time” shipments, total quality requirements and across-the-border delivery organizations.

In order to rationalize the flow of products, it is necessary to use a restricted number of harmonized, standard, durable and reusable containers, which are coordinated in modular fashion with the modulus 1 200 × 800, 1 200 × 1 000 (1 219 × 1 016) and 1 100 × 1 100. These represent universally usable, poolable systems and are especially designed to meet customer and supplier needs, as well as the technical and environmental requirements of the logistic chain.

One of the main goals is to create and promote an overall open system for packaging and equipment for unit loads to facilitate free border crossing exchange of goods.

This leads to the condition of the more restricted use of standardized packages and unit loads as the main elements of the transportation and distribution of goods and unit loads, “the modular system”.

This document specifies the elements of Small Load Container (SLC) modular systems which are designed to promote reusable primary and transport packaging to protect the environment.

It has to be recognized that a single overall system is unlikely to cover all aspects of distribution chain. For this reason, this document specifies different systems which are dependent on different specification requirements.

Handling and transportation technologies are taken into account by specifying different types of SLC systems.

These containers and the other system elements are designed for handling, storage and transport operations in order to meet the requirements of the transportation chain most efficiently.

This document is based on performance requirements and thus, does not include specific design features. However, it includes essential requirements to allow for third-party assessment and certification of the products if required.

Transport packaging — Small load container systems —

Part 1: Common requirements and test methods

1 Scope

This document specifies the essential characteristics and the common requirements and test methods for SLC systems used in the handling, transport and storage for the automotive industry. The application of such systems is described in [Annex B](#).

These containers are based on the modular area 600 mm × 400 mm, 550 mm × 366 mm and 600 mm × 500 mm and subdivisions according to ISO 3394 and ISO 3676.

This document is designed to be read in conjunction with the particular part which specifies the chosen system.

2 Normative references

The following documents are referred to in the text in such a way that some or all of their content constitutes requirements of this document. For dated references, only the edition cited applies. For undated references, the latest edition of the referenced document (including any amendments) applies.

ISO 2234, *Packaging — Complete, filled transport packages and unit loads — Stacking tests using a static load*

ISO 2248, *Packaging — Complete, filled transport packages — Vertical impact test by dropping*

ISO 3676, *Packaging — Complete, filled transport packages and unit loads — Unit load dimensions*

IEC 61340-2-3, *Electrostatics — Part 2-3: Methods of test for determining the resistance and resistivity of solid materials used to avoid electrostatic charge accumulation*

3 Terms and definitions

For the purposes of this document, the terms and definitions given in ISO 21067, ISO/TS 19709-2, ISO/TS 19709-3 and the following apply.

ISO and IEC maintain terminological databases for use in standardization at the following addresses:

- IEC Electropedia: available at <http://www.electropedia.org/>
- ISO Online browsing platform: available at <http://www.iso.org/obp>

3.1

ends

two shortest vertical walls of an *SLC* ([3.5](#))

ISO 19709-1:2016(E)

3.2

nominal load

recommended maximum mass of container contents, lowest safe load value for the specified support conditions, independent of the type of load (excluding concentrated loads)

[SOURCE: ISO 445:2013, 2.2, modified, “recommended maximum mass of container contents” added, Note 1 and Note 2 removed.]

3.3

nominal stacking load

recommended maximum mass applied to the top of the lowest *SLC* (3.5) in a stack

3.4

sides

two longest vertical walls of an *SLC* (3.5)

3.5

small load container

SLC

open-topped durable, reusable, rigid, rectangular modular container which can be handled manually and/or mechanically and is the central element of a *SLC* system

3.6

system

entity consisting of interdependent components

[SOURCE: ISO 3676:2012, 3.2]

4 Module capacity

These *SLC* systems are based on the area module 600 mm × 400 mm according to ISO 3394. They shall be compatible with the international standardized unit load sizes 1 200 mm × 800 mm and/or 1 200 mm × 1 000 mm according to ISO 3676.

NOTE The *SLC* patterns identified for 1 000 × 1 200 will also be accommodated by a 1 016 × 1 219 pallet (North American standard GMA size). The ideal pallet size to transport the containers with an area module of 550 mm × 366 mm is 1 100 mm × 1 100 mm.

The plan view dimensions of the system elements specified shall be subdivisions or multiples of the area module with the following nominal sizes, for example:

- 300 mm × 200 mm, 400 mm × 300 mm, 600 mm × 400 mm;
- 550 mm × 366 mm, 366 mm × 275 mm, 366 mm × 183 mm;
- 600 mm × 500 mm, 500 mm × 300 mm, 300 mm × 250 mm.

Carrying handles and label frames are separated. Exceptions are BSS-*SLC* and CSS-*SLC* with height 147,5 mm, for which the label frame on the end face is integrated in the carrying handle.

5 *SLC* system elements designation

- *SLC* is an open container (with footprint up to 600 mm × 400 mm) for receiving bulk goods and components.
- CSS-*SLC* is an adaptation or system extension to meet the requirements of new supply chains (see [Figure 1](#)). Features are single-walled *SLC* design, rigid, filling mass up to 20 kg and flat base (see ISO/TS 19709-2).

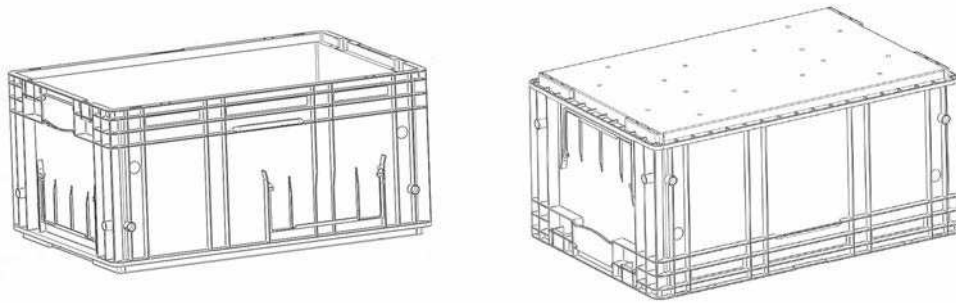

Figure 1 — View of a CSS-SLC 6280

EXAMPLE 6280 SLC means a SLC with the following dimensions: length 600 mm, width 400 mm and height 280 mm.

- BSS-SLC is an adaptation or system extension to meet the requirements of new supply chains (see [Figure 2](#)). Features are single-walled SLC design, rigid, filling mass up to 20 kg and composite base (see ISO/TS 19709-3).

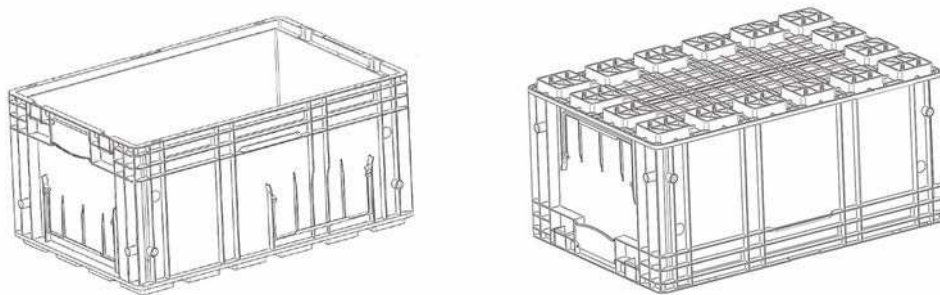

Figure 2 — View of a BSS-SLC 6429

EXAMPLE 6429 SLC means a SLC with the following dimensions: length 600 mm, width 400 mm and height 280 mm.

6 Loads

The maximum loads per SLC may not exceed 20 kg.

7 Requirements

7.1 Quality conditions

The SLC system elements shall have uniform, matte colouring and smooth surfaces that are free of foreign objects, cavities, cracks, webbing and other defects. Minor shallow, processing-related unevenness and pockmarks are permissible if they do not impair fitness for use. Test methods to determine fitness for purpose of SLCs shall be conducted in accordance with [Annex A](#).

7.2 Stack stability

There shall be no risk of stacked SLC units collapsing when operated either in unit loads or single stack columns. This applies both to static and dynamic situations.

When tested in accordance with [A.2.2](#):

- a) the stack formed by the three SLCs shall keep its stability during and after the test;
- b) the deflection over the height of the stack under load is defined as the average value of the reduction between the first and second measurement and shall be less than 2 % of the height;
- c) the residual deflection over the height of the stack is defined as the average value of the reduction between the first and third measurement and shall be less than 1 % of the height.

7.3 Base deflection in the condition as delivered

The following specified dimensional tolerances for base deflection shall be maintained and apply for $(23 \pm 2) \text{ }^\circ\text{C}$ (see [Figure 3](#) and [Table 1](#)). These apply while empty, as delivered from the manufacturer, before use.

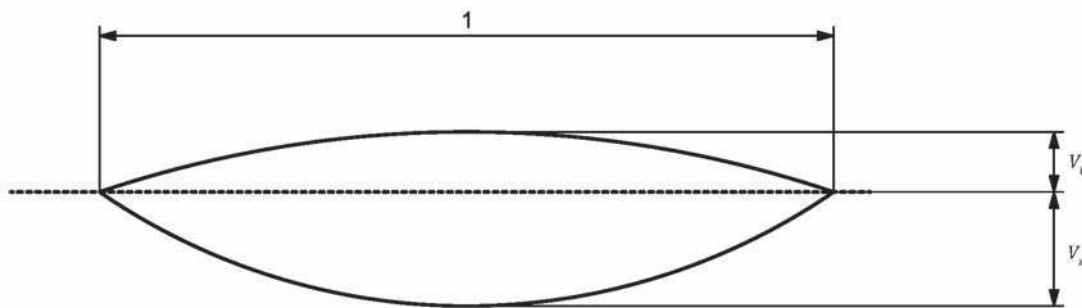

Key

- 1 long side
- V_i inward deflection
- V_a outward deflection

Figure 3 — Base deflection using the example CSS-SLC, 400 mm × 300 mm

Table 1 — Base deflection condition on delivery

Dimension in millimetres

	Modulus 600 × 400 550 × 366 600 × 500		Modulus 400 × 300 366 × 275 500 × 300		Modulus 300 × 200 366 × 183 300 × 250	
	V_a	V_i	V_a	V_i	V_a	V_i
BSS-SLC	1	4	1	3	0	5
CSS-SLC	0	7	0	5	0	5

NOTE In each case, the measuring point is the middle of the container base.

8 Material

The material used shall be recoverable.

The user and the supplier shall agree that the operating temperature and the resistance to chemicals, e.g. acids, oils, coolants, brake fluids, and especially to washing agents, are compatible with the element material specified.

The SLC manufacturer shall ensure that any colouring agent used is compatible with the raw material.

NOTE Information on the use of colour as a means of identification is given in ISO/TS 19709-2 and ISO/TS 19709-3.

SLC manufacturers pledge to use only polypropylene copolymers for all SLC system elements in order to maintain consistent quality. The use of foamed plastics is prohibited.

This document does not cover test conditions for raw materials. However, the finished SLCs shall fulfil the quality and test requirements set out in this document.

The colour tolerances in delivered condition are checked by colour measurements. See ISO/TS 19709-2 and ISO/TS 19709-3 for details.

All plastics shall be UV-stabilized. See [Annex C](#) for details.

SLCs shall be able to withstand washing processes and cleaning agents in accordance with the details provided in [Annex C](#).

9 Marking and labelling

9.1 Marking

The following data is engraved on BSS-SLC and CSS-SLC tools during manufacturing (see [Table 2](#)). In [Table 2](#) and [Table 3](#):

- “n” means numeric;
- “an” means alphanumeric;
- “n4” means numeric with a 4 digit range;
- “MMYY” means a two-digit month, followed immediately by a two-digit year.

Table 2 — Label on BSS-SLC and CSS-SLC during manufacturing

Data content	Format	Arrangement
BSS-SLC type no.	n4 e.g. 6429	On both long sides
CSS-SLC type no.	n4 e.g. 6280	On both long sides
Tare mass	n3 expressed in kilograms format: x,xx kg, e.g. 2,97 kg	On both long sides
NOTE 1 The recycling symbol according to ISO 14021:2016, 5.10.2.1 relates only to the SLC, not to the content of the SLC.		
NOTE 2 If unique labelling is required, ISO/IEC 15459-5 can be used.		

Table 2 (continued)

Data content	Format	Arrangement
SLC manufacturer name	an1..50 name or company logo	At least once, preferably on a long side
Date of manufacture	n4 format: MMY	At least once preferably on a long side
Environment and recycling symbol	In accordance with ISO 14021:2016, 5.10.2.1 in (see Note 1)	At least once, on a long or short side
NOTE 1 The recycling symbol according to ISO 14021:2016, 5.10.2.1 relates only to the SLC, not to the content of the SLC.		
NOTE 2 If unique labelling is required, ISO/IEC 15459-5 can be used.		

The following data is engraved on the SLC lid tool during manufacturing (see [Table 3](#)).

Table 3 — Information on SLC lid during manufacturing

Data content	Form	Arrangement
Lid type	an3 e.g. D65 ^a	Top side
Tare	n3 expressed in kilograms, format: x,xx kg e.g. 0,52 kg	Bottom side
SLC manufacturer name	an1..50 name or company logo	Bottom side
Date of manufacture	n4 format: MMY	Bottom side
Environment and recycling symbol	In accordance with ISO 14021:2016, 5.10.2.1 (see Note 1 in Table 2)	Bottom side
^a For example, D 65 means lid for 600 mm × 400 mm containers.		

9.2 Labelling

SLCs shall be provided with at least one label holder. The location of the labels shall be such as to permit scanning and automatic affixing (see [Figure 4](#)).

NOTE Label size and location are specified in ISO/TS 19709-2 and ISO/TS 19709-3.

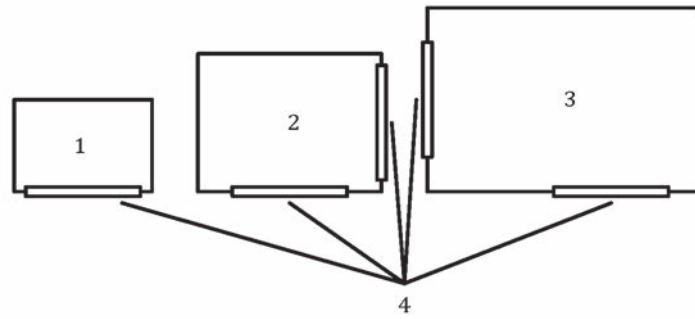
**Key**

- 1 SLC 3...
- 2 SLC 4...
- 3 SLC 6...
- 4 label frame

Figure 4 — Schematic depiction of label frame locations

Annex A **(normative)**

Testing

A.1 Requirements before testing

A.1.1 General

All tests shall be conducted on new unused SLC system elements.

Test shall be conducted not earlier than 72 h after the manufacture of the element.

SLC system elements shall exhibit a uniform, matte colouring and smooth surfaces, which shall be free from foreign objects, blowholes, cracks, webbing and other defects. Minor shallow, processing-related unevenness and pock marks are permissible if they do not impair fitness for use. Further quality conditions are described in the following subclauses.

A.1.2 Conditioning before testing

SLC elements submitted for testing shall be preconditioned for at least 24 h at (23 ± 2) °C. Unless otherwise specified, the tests shall be conducted under the preconditioning conditions.

A.1.3 Dimensions

Dimensions and dimensional tolerances of containers are given in ISO/TS 19709-2 and ISO/TS 19709-3.

When measured on three elements sampled at random, the dimensional and tare mass requirements specified in the relevant part shall be met.

A.1.4 Masses

12 each empty, dry SLC system elements shall be weighed individually.

The tare mass of any SLC system element may not deviate from the target mass for that element by more than ± 1 %.

A.1.5 Test load

The test load shall be the nominal load or the nominal stacking load multiplied by the safety factor.

The safety factor shall be at least 1,5 (apply only for stacking test).

A.1.6 Test ballast

Any test ballast required for a particular test shall create a uniformly spread test load occupying more than 80 % of the container capacity. It shall be composed either of the actual product with which the SLC element under test is to be used or of either of two types of fabric or plastic film test bags as follows.

Type A:

- Flat dimensions of empty bag: 150 mm × 200 mm.
- Load: 500 g of plastic granules.

Type B:

- Flat dimensions of empty bag: 100 mm × 100 mm.
- Load: 500 g of steel balls having a diameter of 5 mm to 8 mm.
- Where both types of ballast are used in a container, ballast B is placed first in the base of the container and then ballast A above.
- When the actual product is used as a test load, the approval shall only be valid for that product.

A.2 Test methods

A.2.1 Drop test

A.2.1.1 Method

The drop tests on individual empty SLCs shall be performed in accordance with ISO 2248 using the test parameters shown in [Table A.1](#). The drop test shall be performed on individual SLCs in the orientations as shown in [A.2.1.2](#).

Table A.1 — Drop test conditions

Number of test	Pre-conditioning °C	Test load	Drop height m	Number of repetitions
1	-18 ± 2	—	2,50	5
2	23 ± 2	—	4,0	5
3	50 ± 2	—	4,0	5

All tests are conducted at (23 ± 2) °C immediately after preconditioning. When the test procedure exceeds 4 min, the SLCs shall be reconditioned for a minimum period of 30 min. Each drop test series (see [A.2.1.2](#) a) to d)) is conducted on a new SLC.

A.2.1.2 Sequence

The sequence of drops for every test shall be as follows:

- a) impact on to whole SLC base;
- b) impact on to lower longitudinal edge;
- c) impact on to lower lateral edge;
- d) impact on to one lower corner of the SLC base.

The container shall be positioned as if suspended from the opposite corner, edge or side to be tested (see [Figure A.1](#)).







	Longitudinal view	Lateral view
a) Impact on to whole container base		
b) Example: impact on to lower longitudinal edge		
c) Example: impact on to lower lateral edge		
d) Example: impact on to one lower corner to lower diagonal line of the container base		

Figure A.1 — Drop test sequence

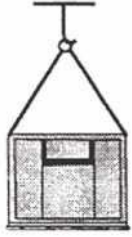
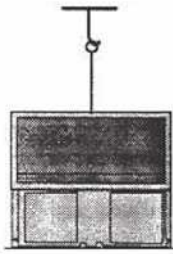
A.2.2 Stacking test using static load

A.2.2.1 Test parameters

The following parameters shall be used:

- a) temperature of test: $(23 \pm 2) \text{ }^\circ\text{C}$;
- b) number of repetitions: three tests using three new SLCs per test (total number: 9 SLCs);
- c) loading:
 - 1) first: 10 % of the test load (pre-load);

- 2) second: 100 % of the test load;
- 3) third: 10 % of the test load (pre-load).

A.2.2.2 Test method

The test shall be carried out in accordance with ISO 2234 and the test method chosen shall be recorded.

Stack three empty SLCs. Place a test load via a flat rigid surface on the top SLC (see [Figure A.2](#)).

Take measurements (expressed in millimetres) at each corner of the stack between the placement level and the surface of application of the test load:

- a) first measurement with 10 % of the test load (pre-load) at $(23 \pm 2) ^\circ\text{C}$;
- b) second measurement with 100 % of the test load after 96 h at $(23 \pm 2) ^\circ\text{C}$;
- c) relaxation: the test load is reduced to the pre-load and the stack is placed at $(23 \pm 2) ^\circ\text{C}$ for 24 h;
- d) third measurement with 10 % of the test load (pre-load) at $(23 \pm 2) ^\circ\text{C}$.

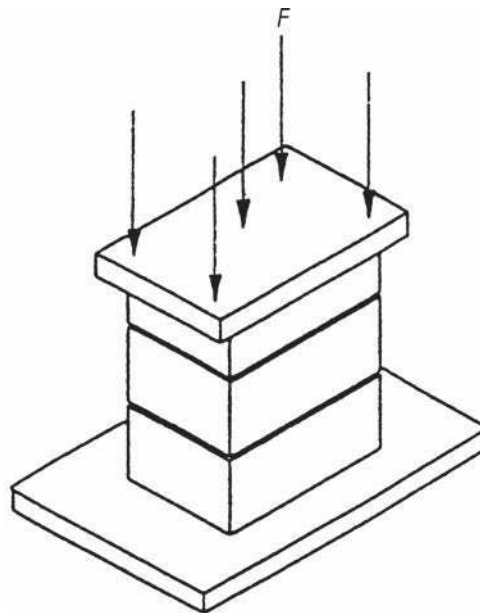

Figure A.2 — Static test using static load

A.2.3 Crush pressure tests in accordance with ISO 12048

A.2.3.1 Test parameters

Precondition SLC samples at $(23 \pm 2) ^\circ\text{C}$ for not less than 24 h.

SLCs shall be tested empty.

Test machine plate speed shall be 12,5 mm/min.

Record break force for each SLC and calculate average.

Minimum break loads for various SLC models are shown in [Table A.2](#).

Table A.2 — Minimum break loads for various SLC models

SLC model	Nominal dimensions L × W × H mm	Minimum break load daN
3147/3215	300 × 200 × 147	2 000
4147/4315	400 × 300 × 147	3 600
4280/4329	400 × 300 × 280	2 900
6147/6415	600 × 400 × 147	3 000
6280/6429	600 × 400 × 280	2 600

A.2.3.2 Test method

The SLCs shall be conditioned at the temperatures stated below for 24 h before each test.

Three SLCs stacked on top of each other are subjected to pressure until they break and/or recognizable deformation or a distinct decrease in the applied force is observed, and the crush strength is determined.

In order to determine the crushing pressure at the breaking load, the empty SLCs shall be placed between the pressure plates of a pressure testing machine and subjected to pressure by moving the plates towards each other.

The test is performed three times with three new test specimens each time, and the average value is then calculated.

A.2.4 Base deflection test

A.2.4.1 General

This test is performed to determine the permanent deformation of the base surface due to loading in a crossways position on angle rails. Permanent deformation of the base may affect the stackability of the containers.

A.2.4.2 Test parameters

The following parameters shall be used:

- a) temperature of test: (23 ± 2) °C;
- b) number of samples: 3 SLCs;
- c) bulk loading: 20 kg (see [A.1.6](#)).

A.2.4.3 Test method

- a) First measurement at (23 ± 2) °C with a ballast of 10 % of the test load (pre-load).
- b) Second measurement after 96 h at (23 ± 2) °C, with a ballast of 100 % of the test load.
- c) Relaxation: reduce the ballast to the pre-load of 10 % and maintain the SLC, still remaining on its support (either an identical SLC or a support assembly) at (23 ± 2) °C.
- d) Third measurement at (23 ± 2) °C with ballast of 10 % of the test load (pre-load).

Type of test:

The SLC shall be filled uniformly with bulk goods and stored for 96 h on its stacking edge, in crossways position, on angle rails. The edge width resting on the angle rails is 10 mm (see [Figure A.3](#)).

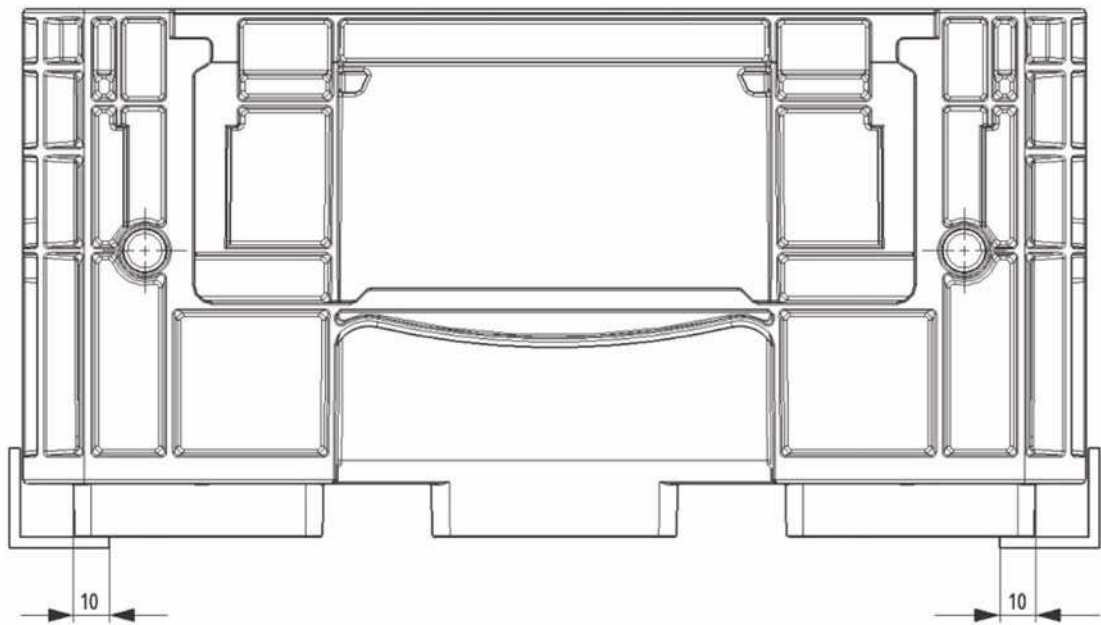
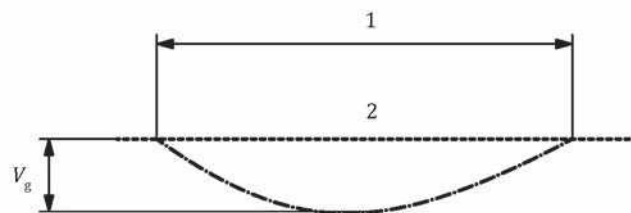

Figure A.3 — Positioning of container during testing

The deformation, V_g , of the base 24 h after removal of the load may not exceed the maximum value of V_g (relative to the zero line) specified in [Table 1](#) (see [Figure A.4](#)).



Key

1 long side

2 zero line

V_g maximum residual deflection relative to the zero line after removal of load

Figure A.4 — Base deformation and zero line using the example CSS-SLC, 400 mm × 300 mm

Table A.3 — Base deformation condition after testing

Dimension in millimetres

	Modulus 600 × 400 550 × 366 600 × 500	Modulus 400 × 300 366 × 275 500 × 300	Modulus 300 × 200 366 × 183 300 × 250
	V_g	V_g	V_g
BSS-SLC	5	3	3
CSS-SLC	7	5	5

NOTE In each case, the measuring point is the middle of the container base.

A.2.5 Surface electrical resistance test of BSS-SLC system elements (Electrostatic discharge, ESD)

The surface electrical resistant test is carried out in accordance with IEC 61340-2-3. The Surface electrical resistance shall be measured at the bottom of the containers. Here, the measuring points shall be at least 250 mm away from each other (excepting areas of joint lines). An exception is given for BSS-SLC 3115 (ESD). Here, the electrodes should be positioned as far as possible in the corner regions.

Before measurement, SLC shall be conditioned as follows:

- qualification: standard conditions (23 °C ± 2 °C), relative humidity (12 % ± 3 %) for 48 h;
- verification: room temperature and 50 % ± 3 % humidity for 12 h.

The measurement surface shall be free of dust. The measured average surface electrical resistance, x , shall be $1 \times 10^4 \Omega \leq x \leq 5 \times 10^{10} \Omega$.

Annex B (informative)

Applications

B.1 General

The use of standard modular areas for unit loads in transport packaging is an important element of dimensional coordination in the distribution chain. The overall aim is to ensure that all links in the chain (e.g. shelves, transport packaging, unit loads, pallets, containers, transport vehicles loading and unloading equipment, storage facilities) are dimensionally coordinated and therefore compatible with one another.

SLCs, as central elements of transportation chains, have a wide range of interactions with other sub-systems, e.g. loads, operator ergonomics, environmental parameters, transport systems, organization-information-control systems, production and handling systems, conveyer and storage systems, and dimensional coordination makes a significant contribution to the efficiency of an entire distribution system.

For SLC systems, preference is given to transport packaging which fits into the standard 600 mm × 400 mm, 550 mm × 366 mm or 600 mm × 500 mm area module or one of their sub-multiples (ranging from 600 mm × 400 mm to 300 mm × 200 mm, 550 mm × 366 mm to 366 mm × 186 mm or 600 mm × 500 mm to 300 mm × 250 mm).

There are two principal types of SL system: the column stackable system (CSS) and the bond stackable system (BSS), which are specified in ISO/TS 19709-2 and ISO/TS 19709-3, respectively.

B.2 Transport system

All containers of an SLC system are suitable to form unit loads on modular unit load sizes, but they may also be handled as single delivery units. All SLCs can be stacked in columns to form unit loads (homogeneous unit loads).

It is essential that maximum applied loads be respected while forming unit loads. Maximum loads and applied loads are given in ISO/TS 19709-2 and ISO/TS 19709-3.

The “standard unit load” includes pallets, stacks of containers and lids and/or covers, if required.

Different containers of a system or the combination of elements of several systems form a “mixed unit load”. (See ISO/TS 19709-2 and ISO/TS 19709-3.)

Securing a unit load may be accomplished by straps shrink or stretch wrapping or by self-securing.

With stackable systems, the transport volume of components is the same whether they are filled or empty.

B.3 Handling system

All SLCs are designed for manual and mechanical handling (e.g. conveying and lifting devices).

For handling by grippers, the characteristics of holes and grooves are specific to each system, and are specified in ISO/TS 19709-2 and ISO/TS 19709-3.

B.4 Conveyer system

All containers with flat and plain bases can be moved on all roller-, ball-, multi-directional rollers, roll tables, chain- or belt conveyers.

Containers with other base configurations need accessories or conveyers as specified in ISO/TS 19709-2 and ISO/TS 19709-3.

Annex C **(normative)**

UV stabilization and cleaning

C.1 Control of UV stabilization

If new PP copolymers are used, UV stabilization shall be performed, such that the delivered products contain at least 0,1 % of low-molecular-weight hindered amine light stabilizer (HALS) and 0,1 % of high-molecular-weight HALS.

If recycled PP copolymers are used, suitable measures shall be taken to ensure that the above-mentioned HALS values are achieved.

C.2 Cleaning SLCs

The following conditions shall be ensured in the cleaning of SLCs:

The combination of the detergent and the washing parameters shall not have an aggressive effect on the SLCs. Washing temperatures up to 60 °C shall not cause problems. At higher temperatures, tests shall be performed with various combinations of detergent, dwell time and nozzle pressure.

Drying temperatures up to 60 °C shall not cause problems. At higher temperatures, tests with various dwell times shall be performed.

Bibliography

- [1] ISO 445, *Pallets for materials handling — Vocabulary*
- [2] ISO 18616-1,¹⁾ *Transport packaging — Reusable, rigid plastics distribution boxes — Part 1: General purpose application*
- [3] ISO 18616-2,²⁾ *Transport packaging — Reusable, rigid plastics distribution boxes — Part 2: General specifications for testing*
- [4] ISO 21067, *Packaging — Vocabulary*
- [5] ISO/IEC 15459-5, *Information technology — Automatic identification and data capture techniques — Unique identification — Part 5: Individual returnable transport items (RTIs)*
- [6] RAL 5003, RAL-colour codes
- [7] RAL 5005, RAL-colour codes
- [8] ISO 3394, *Packaging — Complete, filled transport packages and unit loads — Dimensions of rigid rectangular packages*
- [9] ISO 12048, *Packaging — Complete, filled transport packages — Compression and stacking tests using a compression tester*
- [10] ISO 14021:2016, *Environmental labels and declarations — Self-declared environmental claims (Type II environmental labelling)*
- [11] ISO/TS 19709-2, *Transport packaging — Small load container systems — Part 2: Column Stackable System (CSS)*
- [12] ISO/TS 19709-3, *Transport packaging — Small load container systems — Part 3: Bond Stackable System (BSS)*

1) To be published.

2) To be published.

