

---

---

**Metallic and other inorganic  
coatings — Measurement of Young's  
modulus of thermal barrier coatings  
by beam bending**

*Revêtements métalliques et autres revêtements inorganiques —  
Mesurage du module de Young des revêtements barrières thermiques  
par flexion de poutre*



**COPYRIGHT PROTECTED DOCUMENT**

© ISO 2016, Published in Switzerland

All rights reserved. Unless otherwise specified, no part of this publication may be reproduced or utilized otherwise in any form or by any means, electronic or mechanical, including photocopying, or posting on the internet or an intranet, without prior written permission. Permission can be requested from either ISO at the address below or ISO's member body in the country of the requester.

ISO copyright office  
Ch. de Blandonnet 8 • CP 401  
CH-1214 Vernier, Geneva, Switzerland  
Tel. +41 22 749 01 11  
Fax +41 22 749 09 47  
copyright@iso.org  
www.iso.org

# Contents

Page

Foreword .....	iv
Introduction .....	v
<b>1 Scope .....</b>	<b>1</b>
<b>2 Normative references .....</b>	<b>1</b>
<b>3 Terms and definitions .....</b>	<b>1</b>
<b>4 Principle .....</b>	<b>2</b>
<b>5 Apparatus for measuring Young's modulus .....</b>	<b>2</b>
5.1 Testing machine .....	3
5.2 Four-point bending jig .....	3
5.3 Strain measuring equipment .....	4
<b>6 Specimen .....</b>	<b>4</b>
<b>7 Measuring procedure .....</b>	<b>5</b>
7.1 Specimen dimension .....	5
7.2 Force-strain diagram .....	5
<b>8 Calculation of Young's modulus .....</b>	<b>8</b>
<b>9 Test report .....</b>	<b>9</b>
<b>Annex A (informative) Measurement method of Young's modulus of TBC specimen with significant porosity .....</b>	<b>11</b>
<b>Bibliography .....</b>	<b>14</b>

## Foreword

ISO (the International Organization for Standardization) is a worldwide federation of national standards bodies (ISO member bodies). The work of preparing International Standards is normally carried out through ISO technical committees. Each member body interested in a subject for which a technical committee has been established has the right to be represented on that committee. International organizations, governmental and non-governmental, in liaison with ISO, also take part in the work. ISO collaborates closely with the International Electrotechnical Commission (IEC) on all matters of electrotechnical standardization.

The procedures used to develop this document and those intended for its further maintenance are described in the ISO/IEC Directives, Part 1. In particular the different approval criteria needed for the different types of ISO documents should be noted. This document was drafted in accordance with the editorial rules of the ISO/IEC Directives, Part 2 (see [www.iso.org/directives](http://www.iso.org/directives)).

Attention is drawn to the possibility that some of the elements of this document may be the subject of patent rights. ISO shall not be held responsible for identifying any or all such patent rights. Details of any patent rights identified during the development of the document will be in the Introduction and/or on the ISO list of patent declarations received (see [www.iso.org/patents](http://www.iso.org/patents)).

Any trade name used in this document is information given for the convenience of users and does not constitute an endorsement.

For an explanation on the meaning of ISO specific terms and expressions related to conformity assessment, as well as information about ISO's adherence to the World Trade Organization (WTO) principles in the Technical Barriers to Trade (TBT) see the following URL: [www.iso.org/iso/foreword.html](http://www.iso.org/iso/foreword.html).

The committee responsible for this document is ISO/TC 107, *Metallic and other inorganic coatings*.

## Introduction

Thermal barrier coatings are highly advanced material systems, generally applied to surfaces of hot-section components made of nickel or cobalt-based superalloys, such as combustors, blades, and vanes of power-generation gas turbines in thermal power plants and aero-engines operated at elevated temperatures.

The function of these coatings is to protect metallic components for extended periods at elevated temperatures by employing thermally insulating materials which can sustain an appreciable temperature difference between load bearing alloys and coating surfaces. These coatings permit the high-temperature operation by shielding these components, thereby extending their lives.

Although Young's modulus is an important property of thermal barrier coatings, the existing ISO standard only describes a method for measuring the Young's modulus of monolithic ceramics.

This International Standard specifies a method for measuring the Young's modulus of thermal barrier coatings that consist of multilayers formed on substrate by thermal spraying.

The measuring procedure of this International Standard is applicable for the measurement of the Young's modulus of various thermally sprayed coatings.



# Metallic and other inorganic coatings — Measurement of Young's modulus of thermal barrier coatings by beam bending

## 1 Scope

This International Standard specifies a method for measuring the in-plane Young's modulus, at room temperature, of thermal barrier coatings formed on substrates by thermal spraying.

## 2 Normative references

The following documents, in whole or in part, are normatively referenced in this document and are indispensable for its application. For dated references, only the edition cited applies. For undated references, the latest edition of the referenced document (including any amendments) applies.

ISO 1463, *Metallic and oxide coatings — Measurement of coating thickness — Microscopical method*

ISO 3611, *Geometrical product specifications (GPS) — Dimensional measuring equipment: Micrometers for external measurements — Design and metrological characteristics*

ISO 4287, *Geometrical Product Specifications (GPS) — Surface texture: Profile method — Terms, definitions, and surface texture parameters*

ISO 13385 (all parts), *Geometrical product specifications (GPS) — Dimensional measuring equipment*

ISO 7500-1, *Metallic materials — Calibration and verification of static uniaxial testing machines — Part 1: Tension/compression testing machines — Calibration and verification of the force-measuring system*

ISO 14188, *Metallic and other inorganic coatings — Test methods for measuring thermal cycle resistance and thermal shock resistance for thermal barrier coatings*

## 3 Terms and definitions

For the purposes of this document, the terms and definitions given in ISO 14188 and the following apply.

### 3.1

#### **thermal barrier coating**

#### **TBC**

two-layer coating consisting of a metallic bond coat (BC) and a ceramic top coat (TC), in order to reduce heat transfer from outside of the top coat through the coating to the substrate

Note 1 to entry: See [Figure 1](#).

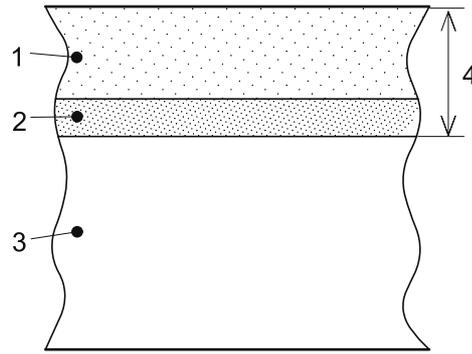

**Key**

- 1 TC
- 2 BC
- 3 substrate
- 4 TBC

**Figure 1 — Diagrammatic view of a section of TBC**

[SOURCE: ISO 14188:2012, 3.1, modified — a different note to entry and figure has been used.]

**3.2**

**composite beam**

beam consisting of multiple layers

**4 Principle**

The fundamental procedures for measuring the Young's moduli of the substrate, BC, and TC consist of the measurement of the force-strain diagram of three types of specimens (substrate, substrate with BC, and substrate with TBC) by a four-point bending method and of calculations according to the theory of composite beam.<sup>[1][2][3][4][5]</sup>

**5 Apparatus for measuring Young's modulus**

An example of the apparatus for measuring the Young's modulus is schematically shown in [Figure 2](#).

The apparatus consists of four-point bending jig, testing machine, and strain measuring equipment.

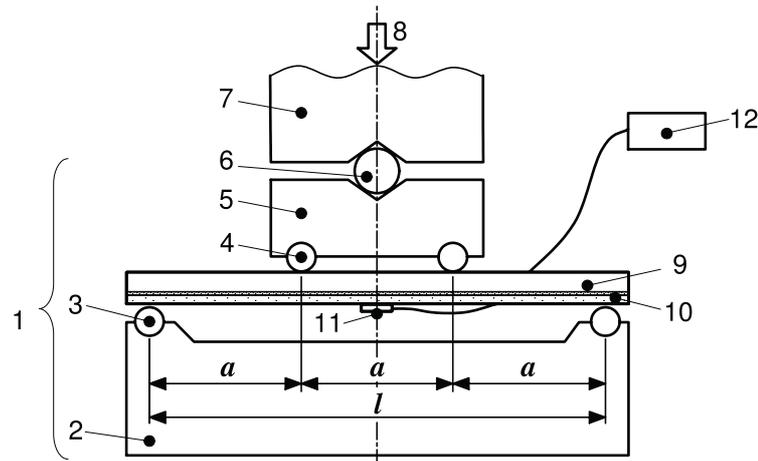

### Key

1	four-point bending jig	9	specimen
2	support bed	10	TBC
3	support roller	11	strain gauge
4	load roller	12	strain measuring equipment
5	load bed	<i>a</i>	distance between load rollers
6	ball	<i>l</i>	distance between support rollers
7	testing machine		
8	force		

**Figure 2 — Typical apparatus for measuring the Young's modulus (in the case that the tensile force is applied to the TBC)**

### 5.1 Testing machine

The testing machine is specified according to ISO 7500-1.

### 5.2 Four-point bending jig

The four-point bending jig consists of the load bed, load roller, support bed, support roller, and ball, as follows.

- The load bed, load roller, support bed, support roller, and ball shall have sufficient rigidity to prevent their plastic deformation during testing.
- The width of load bed, load roller, support bed, and support roller shall be larger than that of specimen.
- The distance between load rollers shall be between 15 mm and 30 mm.
- The distance between support rollers shall be three times the distance between load rollers.
- The radii of support rollers and load rollers shall be the same and shall be between 2,0 mm and 3,0 mm.
- The surface roughness of rollers shall be  $\leq 0,4 \mu\text{m Ra}$  according to ISO 4287.
- The ball is used to ensure that the force is distributed evenly between the left and right load rollers.

### 5.3 Strain measuring equipment

The strain measuring equipment shall be specified as follows.

- a) The strain measuring equipment shall be capable of identifying, to the accuracy of  $\pm 1\%$ , the strain to be measured with the strain gauge.
- b) The strain gauge length should normally be  $\leq 5$  mm.

## 6 Specimen

The specimens shall be specified as follows.

- a) The three types of specimens, the substrate, BC, and TBC specimens shall be used.
- b) The specimen shape is a beam type (see [Figure 3](#)) and the dimensions of the specimen shall be as given in [Table 1](#).

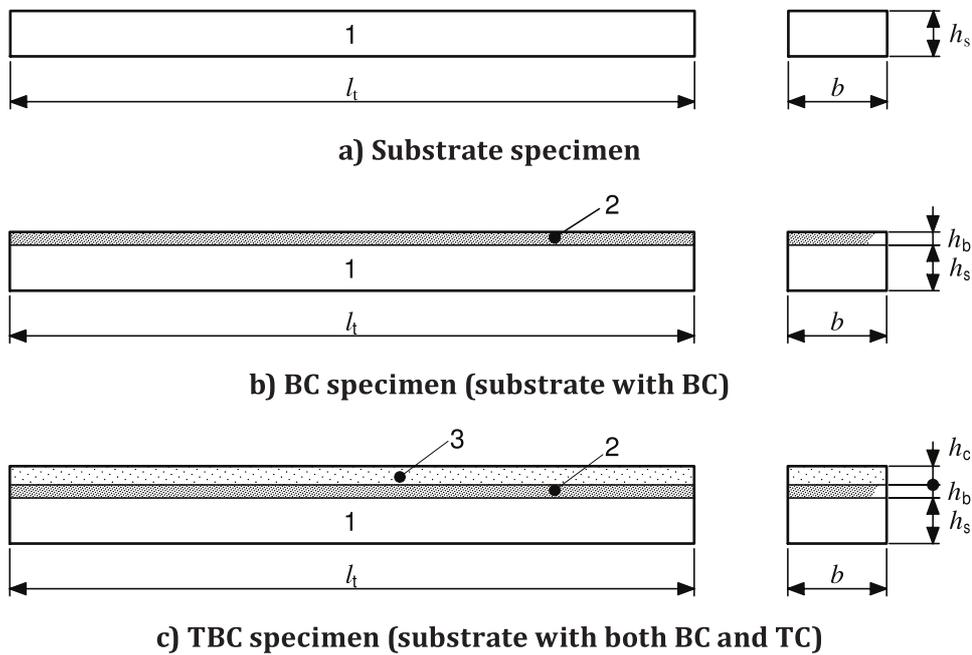

#### Key

- 1 substrate
- 2 BC
- 3 TC
- $l_t$  total length
- $b$  width
- $h_s$  substrate thickness
- $h_b$  BC thickness
- $h_c$  TC thickness

Figure 3 — Shape of specimens

Table 1 — Dimensions of specimen

Symbol	Designation	Dimension
$l$ (mm)	distance between support rollers	$3 a$
$l_t$ (mm)	total length	$l + 6 \leq l_t$
$b$ (mm)	width	$4 \leq b \leq (1/6) l$
$h_s$ (mm)	substrate thickness	$1,5 \leq h_s \leq 3,0$
$h_b$ (mm)	BC thickness	$0,10 \leq h_b$ and $h_s / 20 \leq h_b$ for BC specimen
$h_c$ (mm)	TC thickness	$0,20 \leq h_c$ and $(h_s + h_b) / 10 \leq h_c$ for TBC specimen

- c) The thickness tolerance of the substrate shall be  $\pm 0,01$  mm.
- d) The side surface of the BC and TBC specimens shall be polished to remove the coating deposited on the side surface. The polishing shall be done cautiously so that it does not damage the coating.

## 7 Measuring procedure

### 7.1 Specimen dimension

The dimensions of the specimen shall be measured as follows.

- a) The total length of the specimen shall be measured according to ISO 13385.
- b) The width of the specimen shall be measured according to ISO 3611.
- c) The thickness of the substrate shall be measured according to ISO 3611.
- d) The thickness of BC and TC shall be measured on an image of the coating cross section according to ISO 1463.

### 7.2 Force-strain diagram

- a) The strain gauge shall be attached to the coating surface for the BC and TBC specimens.
- b) The strain gauge shall be attached at the middle portion of the specimen, parallel to the longitudinal direction, as shown in [Figure 4](#).

For the TBC specimen with significant porosity, where adhesive for fixing the strain gauge might significantly penetrate into the coating, measurement should be done according to [Annex A](#).

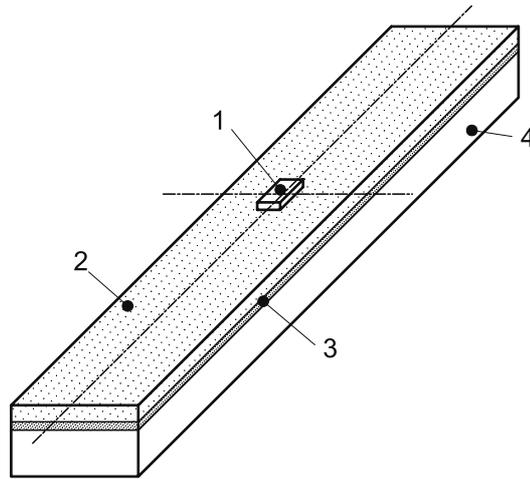

- Key**
- 1 strain gauge
  - 2 TC
  - 3 BC
  - 4 substrate

**Figure 4 — Position of strain gauge**

- c) The specimen shall be placed into the four-point bending jig, as shown in [Figure 5 a\)](#), when tensile force is applied to the coating or as in [Figure 5 b\)](#) when compressive force is applied. The direction of the force applied to the coating shall be decided according to the agreement between parties involved in the transaction.

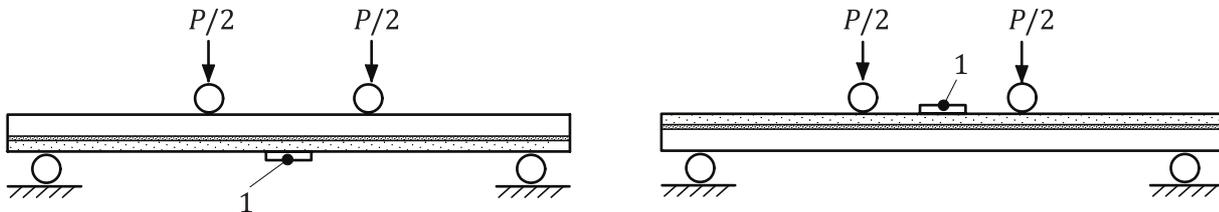

**a) Tensile force**

**b) Compressive force**

- Key**
- 1 strain gauge
  - $P$  force applied to specimen

**Figure 5 — Direction of force applied to the coating by four-point bending**

- d) The test speed shall be  $\leq 0,5$  mm/min.
- e) For the BC and TBC specimens, the force range shall be low enough to prevent damage to the coating and to prevent plastic deformation of the substrate.
- f) The strain range applied to the coating shall be decided according to the agreement between parties involved in the transaction.
- g) The force shall be applied to the specimen repeatedly until the force-strain diagram is stable within the specified force range.

- h) For the substrate specimen, the force–substrate strain diagram shall be measured and its slope determined (see [Figure 6](#)). The measurement shall be carried out three times on one specimen. The average of their slopes shall be used in the calculation of Young’s modulus. This measurement shall be carried out for three specimens prepared using the same procedures.

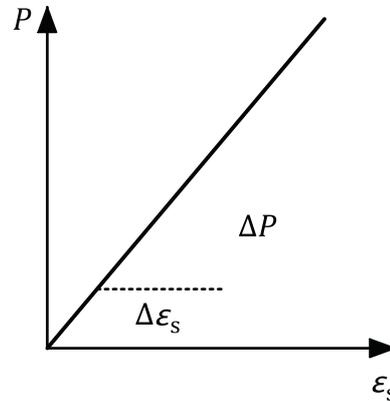

**Key**

$\varepsilon_s$	substrate strain
$P$	force (N)
$\Delta\varepsilon_s$	increment of substrate strain
$\Delta P$	increment of force
$\Delta P/\Delta\varepsilon_s$	slope of force–substrate strain diagram

**Figure 6 — Force–substrate strain diagram**

- i) For the BC specimen, the force–BC strain diagram shall be measured and its slope determined (see [Figure 7](#)). The measurement shall be carried out three times on one specimen. The average of their slopes shall be used in the calculation of Young’s modulus. This measurement shall be carried out for three specimens prepared using the same procedures.

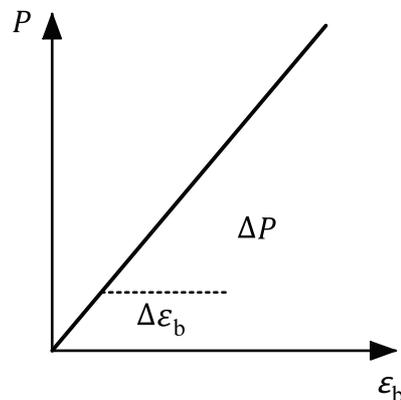

**Key**

$\varepsilon_b$	BC strain
$P$	force (N)
$\Delta\varepsilon_b$	increment of BC strain
$\Delta P$	increment of force
$\Delta P/\Delta\varepsilon_b$	slope of force–BC strain diagram

**Figure 7 — Force–BC strain diagram**

j) For the TBC specimen, the force–TC strain diagram shall be measured and its slope determined (see [Figure 8](#)). The measurement shall be carried out three times on one specimen. The average of their slopes shall be used in the calculation of Young’s modulus. This measurement shall be carried out for three specimens prepared using the same procedures.

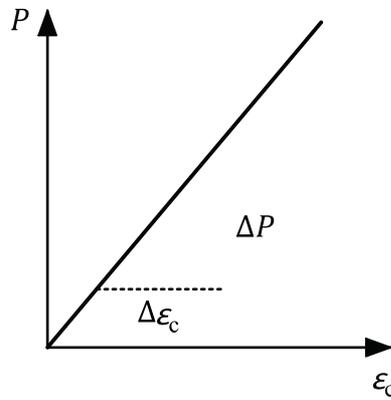

**Key**

- $\epsilon_c$  TC strain
- $P$  force (N)
- $\Delta\epsilon_c$  increment of TC strain
- $\Delta P$  increment of force
- $\Delta P/\Delta\epsilon_c$  slope of force–TC strain diagram

**Figure 8 — Force–TC strain diagram**

**8 Calculation of Young’s modulus**

The Young’s moduli of substrate, BC, and TC shall be calculated as follows.

a) Young’s modulus of the substrate

The Young’s modulus  $E_s$  of substrate shall be calculated according to [Formula \(1\)](#) on the basis of the slope of force–substrate strain diagram measured using the substrate specimen:

$$E_s = \frac{3a}{bh_s^2} \left| \frac{\Delta P}{\Delta \epsilon_s} \right| \tag{1}$$

b) Young’s modulus of BC

The Young’s modulus  $E_b$  of BC shall be calculated according to [Formula \(2\)](#) on the basis of the slope of force–BC strain diagram measured using the BC specimen and  $E_s$  obtained in [Formula \(1\)](#):

$$E_b = \frac{-B + \sqrt{B^2 - 4AC}}{2A} \tag{2}$$

where

$$\left. \begin{aligned} A &= bh_b^4 \\ B &= 2bE_s h_b h_s (2h_b^2 + 3h_b h_s + 2h_s^2) - 3ah_b^2 \left| \frac{\Delta P}{\Delta \varepsilon_b} \right| \\ C &= E_s h_s \left\{ bE_s h_s^3 - 3a \left| \frac{\Delta P}{\Delta \varepsilon_b} \right| (2h_b + h_s) \right\} \end{aligned} \right\}$$

c) Young's modulus of TC

The Young's modulus  $E_c$  of TC shall be calculated according to [Formula \(3\)](#) on the basis of the slope of force–TC strain diagram measured using the TBC specimen,  $E_s$  obtained in [Formula \(1\)](#) and  $E_b$  obtained in [Formula \(2\)](#):

$$E_c = \frac{-B + \sqrt{B^2 - 4AC}}{2A} \quad (3)$$

where

$$\left. \begin{aligned} A &= bh_c^4 \\ B &= 2bE_b h_c h_b (2h_c^2 + 3h_c h_b + 2h_b^2) + 2bE_s h_c h_s \{2h_c^2 + 3h_c h_s + 2h_s^2 + 6h_b (h_c + h_b + h_s)\} - 3ah_c^2 \left| \frac{\Delta P}{\Delta \varepsilon_c} \right| \\ C &= b \left\{ E_b^2 h_b^4 + 2E_b E_s h_b h_s (2h_b^2 + 3h_b h_s + 2h_s^2) + E_s^2 h_s^4 \right\} - 3a \left| \frac{\Delta P}{\Delta \varepsilon_c} \right| \left\{ E_b h_b (2h_c + h_b) + E_s h_s (2h_c + 2h_b + h_s) \right\} \end{aligned} \right\}$$

## 9 Test report

The test report shall contain the following items:

- a) specimen:
  - 1) material of substrate;
  - 2) materials and spraying conditions of BC and TC;
  - 3) shape and dimensions of substrate;
  - 4) thickness of substrate, BC, and TC;
  - 5) width of specimen;
- b) measurement conditions:
  - 1) strain gauge length;
  - 2) distance between load rollers of four-point bending jig;
  - 3) applied force range and strain range applied to coating;
  - 4) test speed;

- 5) direction of force applied to coating;
- c) results of measurement
  - 1) force-strain diagrams of the substrate, BC, and TBC specimens;
  - 2) Young's moduli of substrate, BC, and TC.

## Annex A (informative)

### Measurement method of Young's modulus of TBC specimen with significant porosity

#### A.1 Force–substrate strain method

##### a) TBC specimen

The TC thickness shall be specified in [Table A.1](#). For all other conditions of the specimen, see [Clause 6](#).

**Table A.1 — Dimensions of TBC specimen**

Symbol	Designation	Dimension
$h_c$ (mm)	TC thickness	$0,30 \leq h_c$ and $(3/20)(h_s + h_b) \leq h_c$

##### b) Measuring procedure

- 1) The strain gauge shall be attached to the substrate surface ([Figure A.1](#)). The force–substrate strain diagram shall be measured and its slope determined. The measurement shall be carried out three times on one specimen. The average of their slopes shall be used in the calculation of Young's modulus. This measurement shall be carried out for three specimens prepared using the same procedures.

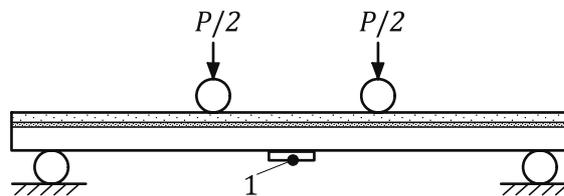

#### Key

- 1 strain gauge to measure the strain ( $\epsilon_s$ ) of substrate  
 P force applied to specimen

**Figure A.1 — Force–substrate strain method**

- 2) The Young's modulus  $E_c$  of TC shall be calculated according to [Formula \(A.1\)](#) on the basis of the slope of the force–substrate strain diagram measured using the TBC specimen,  $E_s$  obtained in [Formula \(1\)](#) and  $E_b$  obtained from [Formula \(2\)](#):

$$E_c = \frac{-B + \sqrt{B^2 - 4AC}}{2A} \quad (\text{A.1})$$

where

$$\left. \begin{aligned} A &= bh_c^4 \\ B &= 2bE_b h_c h_b (2h_c^2 + 3h_c h_b + 2h_b^2) + 2bE_s h_c h_s \{2h_c^2 + 3h_c h_s + 2h_s^2 + 6h_b (h_c + h_b + h_s)\} - 3ah_c \left| \frac{\Delta P}{\Delta \varepsilon_s} \right| (h_c + 2h_b + 2h_s) \\ C &= b \{E_b^2 h_b^4 + 2E_b E_s h_b h_s (2h_b^2 + 3h_b h_s + 2h_s^2) + E_s^2 h_s^4\} - 3a \left| \frac{\Delta P}{\Delta \varepsilon_s} \right| \{E_b h_b (h_b + 2h_s) + E_s h_s^2\} \end{aligned} \right\}$$

where

$\Delta \varepsilon_s$  is increment of substrate strain of TBC specimen;

$\Delta P$  is increment of force;

$\Delta P/\Delta \varepsilon_s$  is slope of force–substrate strain diagram.

## A.2 Force–deflection method

a) TBC specimen

See [A.1 a\)](#).

b) Measuring procedure

- 1) The displacement sensor shall be placed at the middle portion of the specimen ([Figure A.2](#)). The force–deflection ( $y_m$ ) diagram shall be measured and its slope determined. The measurement shall be carried out three times on one specimen. The average of their slopes shall be used in the calculation of Young’s modulus. This measurement shall be carried out for three specimens prepared using the same procedures.

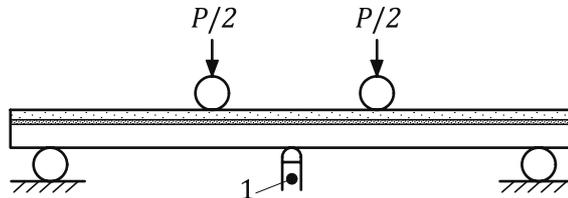

### Key

- 1 displacement sensor
- P force applied to specimen

**Figure A.2 — Force–deflection method**

- 2) The Young’s modulus  $E_c$  of TC shall be calculated according to [Formula \(A.2\)](#) on the basis of the slope of force–deflection diagram measured using the TBC specimen,  $E_s$  obtained in [Formula \(1\)](#) and  $E_b$  obtained in [Formula \(2\)](#):

$$E_c = \frac{-B + \sqrt{B^2 - 4AC}}{2A} \tag{A.2}$$

where

$$\left. \begin{aligned} A &= 4bh_c^4 \\ B &= 8bE_b h_c h_b (2h_c^2 + 3h_c h_b + 2h_b^2) + 8bE_s h_c h_s \{2h_c^2 + 3h_c h_s + 2h_s^2 + 6h_b (h_c + h_b + h_s)\} - 23a^3 h_c \left| \frac{\Delta P}{\Delta y_m} \right| \\ C &= 4b \left\{ E_b^2 h_b^4 + 2E_b E_s h_b h_s (2h_b^2 + 3h_b h_s + 2h_s^2) + E_s^2 h_s^4 \right\} - 23a^3 \left| \frac{\Delta P}{\Delta y_m} \right| (E_b h_b + E_s h_s) \end{aligned} \right\}$$

where

$\Delta y_m$  is increment of deflection of TBC specimen;

$\Delta P$  is increment of force;

$\Delta P/\Delta y_m$  is slope of force–deflection diagram.

## Bibliography

- [1] BEGHINI M., BERTINI L., FRENO F. Measurement of Coatings' Elastic Properties by Mechanical Methods: Part 1. Consideration on Experimental Errors. *Exp. Mech.* 2001 December, **41** (4) pp. 293–304
- [2] BEGHINI M., BENAMATI G., BERTINI L., FRENO F. Measurement of Coating's Elastic Properties by Mechanical Methods: Part 2. Application to Thermal Barrier Coatings. *Exp. Mech.* 2001 December, **41** (4) pp. 305–311
- [3] WAKI H., FUJIOKA H., HARADA Y., OKAZAKI M., KAWASAKI A. Young's Modulus of Thermal Barrier Coating and Oxidation Resistant Coating Bonded to Stainless Substrate by Four-Point Bending. *Journal of Solid Mechanics and Materials Eng.* 2010, **4** (2) pp. 274–285
- [4] HAMAMOTO R., KATO M., AKEBONO H., SUGETA A., KOJIMA Y. Influence of Specimen Twisting on Young's Modulus of Thermal Barrier Coating Measured by Four Points Bending Test, *Proc. the 5th Asian Thermal Spray Conference*, 2012, pp. 161–162
- [5] WAKI H., OIKAWA A., KATO M., TAKAHASHI S., KOJIMA Y., ONO F. Evaluation of the Accuracy of Young's Moduli of Thermal Barrier Coatings Determined on the Basis of Composite Beam Theory. *J. Therm. Spray Technol.* 2014, **23** (8) pp. 1291–1301



