

---

---

**Ships and marine technology —  
Lifesaving and fire protection — Point-  
type resettable flame detectors for  
ships**

*Navires et technologie maritime — Sauvetage et protection contre le  
feu — Détecteurs de flamme ponctuels réglables pour navires*





**COPYRIGHT PROTECTED DOCUMENT**

© ISO 2014

All rights reserved. Unless otherwise specified, no part of this publication may be reproduced or utilized otherwise in any form or by any means, electronic or mechanical, including photocopying, or posting on the internet or an intranet, without prior written permission. Permission can be requested from either ISO at the address below or ISO's member body in the country of the requester.

ISO copyright office  
Case postale 56 • CH-1211 Geneva 20  
Tel. + 41 22 749 01 11  
Fax + 41 22 749 09 47  
E-mail [copyright@iso.org](mailto:copyright@iso.org)  
Web [www.iso.org](http://www.iso.org)

Published in Switzerland

# Contents

	Page
<b>Foreword</b> .....	<b>iv</b>
<b>Introduction</b> .....	<b>v</b>
<b>1 Scope</b> .....	<b>1</b>
<b>2 Normative references</b> .....	<b>1</b>
<b>3 Terms and definitions</b> .....	<b>1</b>
<b>4 General requirements</b> .....	<b>2</b>
<b>5 Marine test requirements</b> .....	<b>2</b>
5.1 General.....	2
5.2 Dry heat (operational).....	2
5.3 Cold (operational).....	3
5.4 Damp heat.....	5
5.5 Salt mist.....	6
5.6 Vibration, sinusoidal (operational).....	7
5.7 High voltage.....	8
5.8 Variation in supply parameters.....	9
5.9 Electrical power-supply failure.....	10
5.10 Insulation resistance.....	10
5.11 Electrostatic discharge immunity.....	11
5.12 Radiated radio-frequency immunity.....	12
5.13 Conducted low-frequency immunity.....	12
5.14 Conducted high-frequency immunity.....	13
5.15 Burst/fast response transient immunity.....	14
5.16 Surge immunity.....	15
5.17 Radiated emission.....	17
<b>Bibliography</b> .....	<b>19</b>

## Foreword

ISO (the International Organization for Standardization) is a worldwide federation of national standards bodies (ISO member bodies). The work of preparing International Standards is normally carried out through ISO technical committees. Each member body interested in a subject for which a technical committee has been established has the right to be represented on that committee. International organizations, governmental and non-governmental, in liaison with ISO, also take part in the work. ISO collaborates closely with the International Electrotechnical Commission (IEC) on all matters of electrotechnical standardization.

The procedures used to develop this document and those intended for its further maintenance are described in the ISO/IEC Directives, Part 1. In particular the different approval criteria needed for the different types of ISO documents should be noted. This document was drafted in accordance with the editorial rules of the ISO/IEC Directives, Part 2 (see [www.iso.org/directives](http://www.iso.org/directives)).

Attention is drawn to the possibility that some of the elements of this document may be the subject of patent rights. ISO shall not be held responsible for identifying any or all such patent rights. Details of any patent rights identified during the development of the document will be in the Introduction and/or on the ISO list of patent declarations received (see [www.iso.org/patents](http://www.iso.org/patents)).

Any trade name used in this document is information given for the convenience of users and does not constitute an endorsement.

For an explanation on the meaning of ISO specific terms and expressions related to conformity assessment, as well as information about ISO's adherence to the WTO principles in the Technical Barriers to Trade (TBT) see the following URL: [Foreword - Supplementary information](#)

The committee responsible for this document is ISO/TC 8, *Ships and marine technology*, Subcommittee SC 1, *Lifesaving and fire protection*.

## Introduction

The 1974 International Convention for the Safety of Life at Sea (SOLAS 1974), as amended, and its associated International Code for Fire Safety Systems (FSS Code) require certain ships to be fitted with fixed fire detection and fire alarm systems, and provide general requirements for such systems.

This International Standard has been developed to supplement the provisions of SOLAS 1974 and the FSS Code by specifying detailed performance criteria and test methods for point-type resettable flame detectors for use in fire detection on ships.

This International Standard has been prepared by Sub-committee ISO/TC 8/SC 1 for point-type, resettable flame detectors on board ships to replace Annex A of ISO 7240-10:2007. This International Standard is based on the performance standards for terrestrial flame detectors in ISO 7240-10 and provides alternative requirements for flame detectors for use in marine applications.



# Ships and marine technology — Lifesaving and fire protection — Point-type resettable flame detectors for ships

## 1 Scope

This International Standard specifies requirements, test methods, and performance criteria for point-type, resettable flame detectors that operate using radiation from a flame, for use in fire detection systems installed on ships. This International Standard references ISO 7240-10 for requirements common to both terrestrial and marine applications and adds the requirements applicable to installations in the shipboard environment.

## 2 Normative references

The following documents, in whole or in part, are normatively referenced in this document and are indispensable for its application. For dated references, only the edition cited applies. For undated references, the latest edition of the referenced document (including any amendments) applies.

ISO 7240-1, *Fire detection and alarm systems — Part 1: General and definitions*

ISO 7240-10:2012, *Fire detection and alarm systems — Part 10: Point-type flame detectors*

IEC 60068-2-1, *Environmental testing — Part 2-1: Tests — Test A: Cold*

IEC 60068-2-2, *Environmental testing — Part 2-2: Tests — Test B: Dry heat*

IEC 60068-2-6, *Environmental testing — Part 2-6: Tests — Test Fc: Vibration (sinusoidal)*

IEC 60068-2-30, *Environmental testing — Part 2-30: Tests — Test Db and guidance: Damp heat, cyclic (12 + 12-hour cycle)*

IEC 60068-2-52, *Environmental testing — Part 2-52: Tests — Test Kb: Salt mist, cyclic (sodium, chloride solution)*

IEC 61000-4-2, *Ed. 1.2:2001 (b) Electromagnetic compatibility (EMC) — Part 4-2: Testing and measurement techniques — Electrostatic discharge immunity test*

IEC 61000-4-4:2004, *Electromagnetic compatibility (EMC) — Part 4-4: Testing and measurement techniques — Electrical fast transient/burst immunity test*

IEC 61000-4-5:2005, *Electromagnetic compatibility (EMC) — Part 4-5: Testing and measurement techniques — Surge immunity test*

IEC 61000-4-6:2006, *Electromagnetic compatibility (EMC) — Part 4-6: Testing and measurement techniques — Immunity to conducted disturbances, induced by radio-frequency fields*

CISPR 16-1, *Specification for radio disturbance and immunity measurement apparatus and methods — Part 1-1: Radio disturbance and immunity measuring apparatus — Measuring apparatus*

CISPR 16-2, *Specification for radio disturbance and immunity measurement apparatus and methods — Part 2-1: Methods of measurement of disturbance and immunity — Conducted disturbance measurements*

## 3 Terms and definitions

For the purposes of this document, the terms and definitions given in ISO 7240-1 and ISO 7240-10 apply.

## 4 General requirements

The apparatus shall comply with all of the requirements of ISO 7240-10:2012 with the exception of 5.7 to 5.17 and Annex D. In lieu of 5.7 to 5.17 of ISO 7240-10:2012, point-type flame detectors for ships shall meet the requirements of [Clause 5](#) of this International Standard.

## 5 Marine test requirements

### 5.1 General

Flame detectors classified for marine applications shall be tested according to the test schedule specified in [Table 1](#).

**Table 1 — Test schedule for marine applications**

Test	Subclause	Specimen number(s)
Reproducibility	ISO 7240-10:2012, 5.2	All specimens
Repeatability	ISO 7240-10:2012, 5.3	1
Directional dependence	ISO 7240-10:2012, 5.4	1
Fire sensitivity	ISO 7240-10:2012, 5.5	All specimens
Dazzling (operational)	ISO 7240-10:2012, 5.6	1
Dry heat (operational)	<a href="#">5.2</a>	2
Cold (operational)	<a href="#">5.3</a>	2
Damp heat	<a href="#">5.4</a>	6
Salt mist	<a href="#">5.5</a>	5
Vibration, sinusoidal (operational)	<a href="#">5.6</a>	4
High voltage	<a href="#">5.7</a>	7
Variation in supply parameters	<a href="#">5.8</a>	1
Electrical power-supply failure	<a href="#">5.9</a>	1
Insulation resistance <sup>a</sup>	<a href="#">5.10</a>	2, 6
Electrostatic discharge immunity	<a href="#">5.11</a>	1
Radiated radio-frequency immunity	<a href="#">5.12</a>	3
Conducted low-frequency immunity	<a href="#">5.13</a>	3
Conducted high-frequency immunity	<a href="#">5.14</a>	3
Burst/fast response transient immunity	<a href="#">5.15</a>	3
Surge immunity	<a href="#">5.16</a>	8
Radiated emission	<a href="#">5.17</a>	1

<sup>a</sup> Measurements shall be performed before and after the relevant environmental tests.

### 5.2 Dry heat (operational)

#### 5.2.1 Object of test

The object of the test is to demonstrate the ability of the specimen to function correctly at high ambient temperatures appropriate to the anticipated service environment.



## 5.2.2 Test procedure and apparatus

### 5.2.2.1 General

The test apparatus and procedure specified in IEC 60068-2-2, Test Bb, and by [5.2.2.2](#) to [5.2.2.4](#) below shall be used.

### 5.2.2.2 State of the specimen during conditioning

Mount the specimen as specified in ISO 7240-10:2012, 5.1.3 and connect it to supply and monitoring equipment as specified in ISO 7240-10:2012, 5.1.2.

### 5.2.2.3 Conditioning

Apply the following conditioning:

- temperature: Starting at an initial air temperature of  $(23 \pm 5)$  °C, increase the air temperature to  $(70 \pm 2)$  °C;
- duration: Maintain the temperature for 2 h.

NOTE Test Bb specifies rates of change of temperature of  $\leq 1$  °C/min for the transitions to and from the conditioning temperature.

### 5.2.2.4 Measurements during conditioning

Monitor the specimen during the conditioning period to detect any alarm or fault signals. During the last 30 min of the conditioning, subject the specimen to the reduced functional test in accordance with ISO 7240-10:2012, 5.1.7.

### 5.2.2.5 Final measurements

After the recovery period of at least 1 h at standard atmospheric conditions, measure the response point of the specimen in accordance with ISO 7240-10:2012, 5.1.6.

Designate the greater of the response points measured in this test and that measured for the same specimen in the reproducibility test as  $D_{\max}$  and the lesser as  $D_{\min}$ .

## 5.2.3 Requirements

No alarm or fault signals shall be given during the transition to the conditioning temperature or during the conditioning.

The specimen shall give an alarm signal in response to the reduced function test.

The ratio point values  $D_{\max}: D_{\min}$  shall be not greater than 1,26.

## 5.3 Cold (operational)

### 5.3.1 Object of test

The object of the test is to demonstrate the ability of the specimen to function correctly at low ambient temperatures appropriate to the anticipated service temperature.

## 5.3.2 Test procedure

### 5.3.2.1 Reference

The test apparatus and procedure specified in IEC 60068-2-1, Test Ab, and by [5.3.2.2](#) to [5.3.2.4](#) below shall be used.

### 5.3.2.2 State of the specimen during conditioning

Mount the specimen as specified in ISO 7240-10:2012, 5.1.3 and connect it to supply and monitoring equipment as specified in ISO 7240-10:2012, 5.1.2.

Measure insulation resistance as specified in [5.10.2.3](#).

### 5.3.2.3 Conditioning

Apply the following conditioning:

- temperature:  $(5 \pm 3) \text{ }^\circ\text{C}$ ;
- duration: 2 h.

For detectors intended for installation on open decks or exposure to the outside weather, apply the following conditioning:

- temperature:  $(-25 \pm 3) \text{ }^\circ\text{C}$ ;
- duration: 2 h.

NOTE Test Ab specifies rates of change of temperature of  $\leq 1 \text{ }^\circ\text{C}/\text{min}$  for the transitions to and from the conditioning temperature.

### 5.3.2.4 Measurements during conditioning

Monitor the specimen during the conditioning period to detect any alarm or fault signals. During the last 30 min of the conditioning, subject the specimen to the reduced functional test in accordance with ISO 7240-10:2012, 5.1.7.

### 5.3.2.5 Final measurements

After the recovery period of at least 1 h at standard atmospheric conditions, measure the response point of the specimen in accordance with ISO 7240-10:2012, 5.1.6.

Designate the greater of the response points measured in this test and that measured for the same specimen in the reproducibility test as  $D_{\max}$  and the lesser as  $D_{\min}$ .

Measure insulation resistance as specified in [5.10.2.3](#).

## 5.3.3 Requirements

No alarm or fault signals shall be given during the transition to or the period at the conditioning temperature.

The specimen shall give an alarm signal in response to the reduced functional test.

The ratio  $D_{\max} : D_{\min}$  shall be not greater than 1,26.

The insulation resistance shall comply with [5.10.3](#).

## 5.4 Damp heat

### 5.4.1 Object of test

The object of the test is to demonstrate the ability of the specimen to function in an environment with high relative humidity where condensation on the equipment can occur.

### 5.4.2 Test procedure

#### 5.4.2.1 Reference

The test apparatus and procedure specified in IEC 60068-2-30, Test Db, and by [5.4.2.2](#) to [5.4.2.4](#) below shall be used.

#### 5.4.2.2 State of the specimen during conditioning

Mount the specimen as specified in ISO 7240-10:2012, 5.1.3.

During the first 12 h of the conditioning, connect the specimen to supply and monitoring equipment as specified in ISO 7240-10:2012, 5.1.2.

During the second 12 h of conditioning, do not supply the specimen with power.

NOTE Any self-test feature intended to monitor the transmission of the detector window can be disabled during this test.

Measure insulation resistance as specified in [5.10.2.3](#).

#### 5.4.2.3 Conditioning

The following severity of conditioning shall be applied:

- temperature:  $(55 \pm 2)$  °C;
- relative humidity:  $(95 \pm 5)$  %;
- duration: 24 h;
- number of cycles: 2.

#### 5.4.2.4 Measurements during conditioning

Monitor the specimen during the conditioning period to detect any alarm or fault signals. During the first 2 h of conditioning, subject the specimen to the reduced functional test described in ISO 7240-10:2012, 5.1.7.

During the last 2 h of conditioning, subject the specimen to the reduced functional test described in ISO 7240-10:2012, 5.1.7.

#### 5.4.2.5 Final measurements

After the recovery period of at least 1 h at standard atmospheric conditions, measure the response point of the specimen in accordance with ISO 7240-10:2012, 5.1.6.

Designate the greater of the response points measured in this test and that measured for the same specimen in the reproducibility test as  $D_{\max}$ , and the lesser as  $D_{\min}$ .

Measure insulation resistance as specified in [5.10.2.3](#).

### **5.4.3 Requirements**

No alarm or fault signals shall be given during the transition to or the period at the conditioning temperature.

The specimen shall give an alarm signal in response to the reduced functional tests.

The ratio  $D_{\max} : D_{\min}$  shall be not greater than 1,26.

The insulation resistance shall comply with [5.10.3](#).

## **5.5 Salt mist**

### **5.5.1 Object of test**

The object of the test is to demonstrate the ability of the specimen to withstand the corrosive effects of salt mist.

### **5.5.2 Test procedure**

#### **5.5.2.1 Reference**

The test apparatus and procedure specified in IEC 60068-2-52, Test Kb shall be used, but carry out the conditioning as specified in [5.5.2.3](#) below.

#### **5.5.2.2 State of the specimen during conditioning**

Mount the specimen as specified in ISO 7240-10:2012, 5.1.3. Do not supply it with power during the conditioning.

Measure insulation resistance as specified in [5.10.2.3](#).

#### **5.5.2.3 Conditioning**

Apply the following conditioning:

- NaCl spray solution: 2 h;
- standing time after spray: 7 d;
- number of cycles: four.

#### **5.5.2.4 Measurements during conditioning**

After the seventh day of each cycle, measure the response point as specified in ISO 7240-10:2012, 5.1.5.

#### **5.5.2.5 Final measurements**

Immediately after the conditioning, measure the response point as specified in ISO 7240-10:2012, 5.1.5.

Designate the greater of the response points measured in this test, and that measured for the same specimen in the reproducibility test as  $D_{\max}$ , and the lesser as  $D_{\min}$ .

Measure insulation resistance as specified in [5.10.2.3](#).

### **5.5.3 Requirements**

No fault signal attributable to the endurance conditioning shall be given on reconnection of the specimen.

The ratio  $D_{\max} : D_{\min}$  shall not be greater than 1,26.

The insulation resistance shall comply with [5.10.3](#).

NOTE The salt mist test is to be carried out for equipment installed in weather exposed areas.

## 5.6 Vibration, sinusoidal (operational)

### 5.6.1 Object of test

The object of the test is to demonstrate the immunity of the specimen to vibration at levels considered appropriate to the normal marine service environment.

### 5.6.2 Test procedure

#### 5.6.2.1 Reference

The test apparatus and procedure specified in IEC 60068-2-6, and in [5.6.2.2](#) to [5.6.2.5](#) below, shall be used.

#### 5.6.2.2 State of the specimen during conditioning

Mount the specimen on a rigid fixture as specified in ISO 7240-10:2012, 5.1.3 and connect it to its supply and monitoring equipment as specified in ISO 7240-10:2012, 5.1.2. Apply the vibration in each of three mutually perpendicular axes in turn so that one of the three axes is perpendicular to the normal mounting plane of the specimen.

#### 5.6.2.3 Conditioning

Apply the conditioning specified in [Table 2](#).

**Table 2 — Vibration test**

Frequency	Amplitude	Acceleration
2(+3/-0) Hz - 13,2 Hz	±1,0 mm	—
13,2 Hz - 100 Hz	—	±0,7 g

If resonance points do not exist, apply the vibration of acceleration  $\pm 0,7 g$  at 30 Hz for 90 min.

Where resonance points are found, either repeat the test with necessary provisions to avoid resonance or apply the vibration, using the same amplitude or acceleration of resonance point, at the resonance frequency for 90 min.

#### 5.6.2.4 Measurements during conditioning

Monitor the specimen during the conditioning period to detect any alarm or fault signals.

Monitor the specimen during the conditioning period for resonance points, at which the amplification factor is  $Q \geq 2$ .

#### 5.6.2.5 Final measurements

After the conditioning, visually inspect the specimen for mechanical damage both internally and externally. Then measure the response point as specified in ISO 7240-10:2012, 5.1.5.

Designate the greater of the response points measured in this test and that measured for the same specimen in the reproducibility test as  $D_{\max}$  and the lesser as  $D_{\min}$ .

### 5.6.3 Requirements

No alarm or fault signals shall be given during the conditioning. No mechanical damage either internally or externally shall result.

The maximum Q shall not exceed 5.

The ratio of the response points  $D_{\max}$ :  $D_{\min}$  shall not be greater than 1,26.

## 5.7 High voltage

### 5.7.1 Object of test

To demonstrate the immunity of the specimen to high voltage surges that can occur in a marine service environment.

### 5.7.2 Test procedure

#### 5.7.2.1 State of the specimen during conditioning

Mount the specimen as specified in ISO 7240-10:2012, 5.1.3, but do not supply it with power during conditioning.

Measure insulation resistance as specified in [5.10.2.3](#).

#### 5.7.2.2 Conditioning

Apply alternating current voltages specified in [Table 3](#) at a frequency of 50 Hz or 60 Hz between current-carrying parts and earth for 1 min.

**Table 3 — Test voltages**

Rated voltage $V_r$ V	Test voltage V
$V_r \leq 65$	$2V_r + 500$
$65 < V_r \leq 250$	1 500
$250 < V_r \leq 500$	2 000
$500 < V_r \leq 690$	2 500

For equipment containing circuits in which electronic apparatus is used and the application of the test voltage is not desirable, the circuits can be removed before applying the test voltages.

#### 5.7.2.3 Measurements during conditioning

Monitor the leakage current during the conditioning period to detect any rapid increase of the current.

#### 5.7.2.4 Final measurements

After the conditioning, measure the response point as specified in ISO 7240-10:2012, 5.1.5.

Designate the greater of the response points measured in this test and that measured for the same specimen in the reproducibility test as  $D_{\max}$  and the lesser as  $D_{\min}$ .

Measure insulation resistance as specified in [5.10.2.3](#).

**5.7.3 Requirements**

The ratio of the response points  $D_{max}$ :  $D_{min}$  shall not be greater than 1,26.

The insulation resistance shall comply with [5.10.3](#).

**5.8 Variation in supply parameters**

**5.8.1 Object of test**

To show that, within the specified range(s) of the supply parameters (e.g. voltage), the response point of the specimen is not unduly dependent on those parameters.

**5.8.2 Test procedure**

**5.8.2.1 State of the specimen during conditioning**

Mount the specimen as specified in ISO 7240-10:2012, 5.1.3 and connect it to supply and monitoring equipment as specified in ISO 7240-10:2012, 5.1.2.

**5.8.2.2 Conditioning**

Apply the supply variation parameters as specified in [Table 4](#).

**Table 4 — Electrical supply variation parameters**

Parameter	Variation from rated value %	
	Voltage	Frequency
Permanent a.c.		
Combination 1	+6	+5
Combination 2	+6	-5
Combination 3	-10	+5
Combination 4	-10	-5
Temporary a.c.		
Combination 5	+20 for 1,5 s	+10 for 5 s
Combination 6	-20 for 1,5 s	-10 for 5 s
d.c.		
For equipment not related to a battery	Tolerance (continuous) ±10 Cyclic variation 5 Ripple 10	—
For equipment related to a battery	-25, +30 for equipment connected to a battery during charging -25, +20 for equipment not connected to a battery during charging	

**5.8.2.3 Measurements during conditioning**

Measure the response point of the specimen as specified in ISO 7240-10:2012, 5.1.5 at the limits specified in [Table 5](#).

Designate the greater of the response points measured in this test and that measured for the same specimen in the reproducibility test as  $D_{max}$  and the lesser as  $D_{min}$ .

In the case of tests “Combination 5” and “Combination 6”, measurement of the response point may be omitted.

### 5.8.3 Requirements

No alarm or fault signals shall be given during the conditioning.

The ratio of the response points,  $D_{\max}:D_{\min}$ , shall not be greater than 1,26.

## 5.9 Electrical power-supply failure

### 5.9.1 Object of test

To demonstrate the ability of the specimen to operate normally following an interruption to the power supply.

### 5.9.2 Test procedure

#### 5.9.2.1 State of the specimen during conditioning

Mount the specimen as specified in ISO 7240-10:2012, 5.1.3 and connect it to supply and monitoring equipment as specified in ISO 7240-10:2012, 5.1.2.

#### 5.9.2.2 Conditioning

Disconnect the power supply to the specimen for a period of 30 s three times over 5 min.

#### 5.9.2.3 Final measurements

After the conditioning, measure the response point as specified in ISO 7240-10:2012, 5.1.5.

Designate the greater of the response points measured in this test and that measured for the same specimen in the reproducibility test as  $D_{\max}$  and the lesser as  $D_{\min}$ .

### 5.9.3 Requirements

No abnormality shall be observed after the power supply equipment is reconnected to the specimen. The equipment shall operate satisfactorily. The ratio of the response points  $D_{\max}:D_{\min}$  shall not be greater than 1,26.

## 5.10 Insulation resistance

### 5.10.1 Object of test

To demonstrate the integrity of the electrical insulation of the specimen before and after the tests in [5.3](#), [5.4](#), [5.5](#), and [5.7](#).

### 5.10.2 Test procedure

#### 5.10.2.1 State of the specimen during conditioning

Mount the specimen as specified in ISO 7240-10:2012, 5.1.3 but do not supply it with power during conditioning.

#### 5.10.2.2 Conditioning

Apply the voltages specified in [Table 5](#) to current carrying parts and between current-carrying parts and earth.



**Table 5 — Test voltages**

Rated voltage $V_r$ V	Test voltage V
$V_r \leq 65$	$2V_r$ and not less than 24
$V_r > 65$	500

For the equipment containing circuits in which electronic apparatus are used and the application of the test voltage is not desirable, apply the test voltage after removing the circuits.

### 5.10.2.3 Final measurements

Measure the insulation resistance between current carrying parts and between current-carrying parts and earth.

### 5.10.3 Requirements

The insulation resistance shall be not less than the value specified in [Table 6](#).

**Table 6 — Insulation resistance**

Rated voltage $V_r$ V	Insulation before environmental test M $\Omega$	Insulation after environmental test M $\Omega$
$V_r \leq 65$	10	1
$V_r > 65$	100	10

## 5.11 Electrostatic discharge immunity

### 5.11.1 Object of test

The object of the test is to demonstrate the immunity of the specimen to the effects of electrostatic discharge.

### 5.11.2 Test procedure

#### 5.11.2.1 Reference

The test procedure as specified in Level 3 of IEC 61000-4-2 shall be performed.

#### 5.11.2.2 State of the specimen during conditioning

Mount the specimen as specified in ISO 7240-10:2012, 5.1.3 and connect it to its supply and monitoring equipment as specified in ISO 7240-10:2012, 5.1.2.

#### 5.11.2.3 Conditioning

Apply the following conditioning to current carrying parts and between current-carrying parts and earth:

- contact discharge: 6 kV;
- air discharge: 8 kV;
- interval between single discharges: 1 s;
- number of pulses: 10/polarity.

#### 5.11.2.4 Final measurements

After the conditioning, measure the response point as specified in ISO 7240-10:2012, 5.1.5.

Designate the greater of the response points measured in this test and that measured for the same specimen in the reproducibility test as  $D_{\max}$  and the lesser as  $D_{\min}$ .

#### 5.11.3 Requirements

No alarm or fault signals shall be given during the conditioning. Degradation, loss of function, or performance, which is self-recoverable, is permissible, but no actual change in operating state or stored data shall occur.

The ratio of the response points,  $D_{\max}:D_{\min}$ , shall not be greater than 1,26.

### 5.12 Radiated radio-frequency immunity

#### 5.12.1 Object of test

The object of the test is to demonstrate the immunity of the specimen to radio-frequency interference.

#### 5.12.2 Test procedure

##### 5.12.2.1 State of the specimen during conditioning

Mount the specimen as specified in ISO 7240-10:2012, 5.1.3 and connect it to its supply and monitoring equipment as specified in ISO 7240-10:2012, 5.1.2.

##### 5.12.2.2 Conditioning

Apply the following conditioning:

- frequency range: 80 MHz to 2 GHz;
- modulation: 80 % AM at 1 kHz;
- field strength: 10 V/m;
- frequency sweep rate:  $\leq 1,5 \times 10^{-3}$  decades (or 1 %/3 s).

##### 5.12.2.3 Final measurements

After the conditioning, measure the response point as specified in ISO 7240-10:2012, 5.1.5.

Designate the greater of the response points measured in this test and that measured for the same specimen in the reproducibility test as  $D_{\max}$  and the lesser as  $D_{\min}$ .

#### 5.12.3 Requirements

No alarm or fault signals shall be given during the conditioning. No degradation or loss of function or performance as defined in the manufacturer's technical specification shall occur.

The ratio of the response points,  $D_{\max}:D_{\min}$ , shall not be greater than 1,26.

### 5.13 Conducted low-frequency immunity

#### 5.13.1 Object of test

The object of the test is to demonstrate the immunity of the specimen to low-frequency interference.

## 5.13.2 Test procedure

### 5.13.2.1 State of the specimen during conditioning

Mount the specimen as specified in ISO 7240-10:2012, 5.1.3 and connect it to its supply and monitoring equipment as specified in ISO 7240-10:2012, 5.1.2.

### 5.13.2.2 Conditioning

Apply the conditioning specified in [Table 7](#).

**Table 7 — Low-frequency immunity parameters**

Test voltage	Frequency <sup>a</sup>	Frequency <sup>b</sup>
10 % of a.c. supply voltage	60 Hz to 900 Hz	50 Hz to 750 Hz
10 % of a.c. supply voltage	900 Hz to 6 kHz	750 Hz to 5 kHz
1 % of a.c. supply voltage	6 kHz to 12 kHz	5 kHz to 10 kHz
10 % of d.c. supply voltage and at least 3 V	50 Hz to 10 kHz	50 Hz to 10 kHz
Maximum power	2 W	2 W
<sup>a</sup> Where rated frequency of the equipment is 60 Hz. <sup>b</sup> Where rated frequency of the equipment is 50 Hz.		

### 5.13.2.3 Final measurements

After the conditioning, measure the response point as specified in ISO 7240-10:2012, 5.1.5.

Designate the greater of the response points measured in this test and that measured for the same specimen in the reproducibility test as  $D_{\max}$  and the lesser as  $D_{\min}$ .

## 5.13.3 Requirements

No alarm or fault signals shall be given during the conditioning. No degradation or loss of function or performance as defined in the manufacturer's technical specification shall occur.

The ratio of the response points,  $D_{\max}: D_{\min}$ , shall not be greater than 1,26.

## 5.14 Conducted high-frequency immunity

### 5.14.1 Object of test

The object of the test is to demonstrate the immunity of the specimen to high-frequency interference.

### 5.14.2 Test procedure

#### 5.14.2.1 Reference

The test procedure as specified in Level 2 of IEC 61000-4-6 shall be performed.

#### 5.14.2.2 State of the specimen during conditioning

Mount the specimen as specified in ISO 7240-10:2012, 5.1.3 and connect it to its supply and monitoring equipment as specified in ISO 7240-10:2012, 5.1.2.

### 5.14.2.3 Conditioning

Apply the following conditioning:

- frequency range: 150 kHz to 80 MHz;
- modulation: 80 % amplitude modulation at 1 kHz;

(If tests of equipment require an input signal with a modulation frequency of 1 kHz, a modulation frequency of 400 Hz should be chosen.)

- amplitude: 3 V r.m.s.

### 5.14.2.4 Final measurements

After the conditioning, measure the response point as specified in ISO 7240-10:2012, 5.1.5.

Designate the greater of the response points measured in this test and that measured for the same specimen in the reproducibility test as  $D_{\max}$  and the lesser as  $D_{\min}$ .

### 5.14.3 Requirements

No alarm or fault signals shall be given during the conditioning. No degradation or loss of function or performance as defined in the manufacturer's technical specification shall occur.

The ratio of the response points,  $D_{\max} : D_{\min}$ , shall not be greater than 1,26.

## 5.15 Burst/fast response transient immunity

### 5.15.1 Object of test

The object of the test is to demonstrate the immunity of the specimen to fast bursts of electrical interference.

### 5.15.2 Test procedure

#### 5.15.2.1 State of the specimen during conditioning

Mount the specimen as specified in ISO 7240-10:2012, 5.1.3 and connect it to its supply and monitoring equipment as specified in ISO 7240-10:2012, 5.1.2.

#### 5.15.2.2 Reference

The test procedure as specified in Level 3 of IEC 61000-4-4 shall be performed.

#### 5.15.2.3 Conditioning

Apply the following conditioning:

- single pulse time: 5 ns (between 10 % and 90 % value);
- single pulse width: 50 ns (50 % value);
- amplitude for line on power supply port and earth: 2 kV;
- amplitude for line on I/O data control and signal lines: 1 kV;
- pulse period: 300 ms;
- burst duration: 15 ms;

— duration: 5 min/polarity.

#### 5.15.2.4 Final measurements

After the conditioning, measure the response point as specified in ISO 7240-10:2012, 5.1.5.

Designate the greater of the response points measured in this test and that measured for the same specimen in the reproducibility test as  $D_{\max}$  and the lesser as  $D_{\min}$ .

#### 5.15.3 Requirements

No alarm or fault signals shall be given during the conditioning. No degradation or loss of function, or performance as defined in the manufacturer's technical specification shall occur.

The ratio of the response points,  $D_{\max} : D_{\min}$ , shall not be greater than 1,26.

### 5.16 Surge immunity

#### 5.16.1 Object of test

The object of the test is to demonstrate the immunity of the specimen to electrical surges.

#### 5.16.2 Test procedure

##### 5.16.2.1 State of the specimen during conditioning

Mount the specimen as specified in ISO 7240-10:2012, 5.1.3 and connect it to its supply and monitoring equipment as specified in ISO 7240-10:2012, 5.1.2.

##### 5.16.2.2 Reference

The test procedure as specified in Level 2 of IEC 61000-4-5 shall be performed.

##### 5.16.2.3 Conditioning

Apply the following conditioning:

- pulse rise time: 1,2  $\mu\text{s}$  (between 10 % and 90 % value);
- single pulse width: 50  $\mu\text{s}$  (50 % value);
- amplitude between line and earth: 1 kV;
- amplitude between lines: 0,5 kV;
- repetition rate:  $\geq 1$  pulse/min;
- number of pulses: 5/polarity.

Where the power and signal lines are identical, the test procedure shall be in accordance with [Figure 1](#).

During the test, switch S1 to test positions 1 to 4, but not in the same position as S2.

During the test, switch S2 to test positions 1 to 4, but not in the same position as S1.

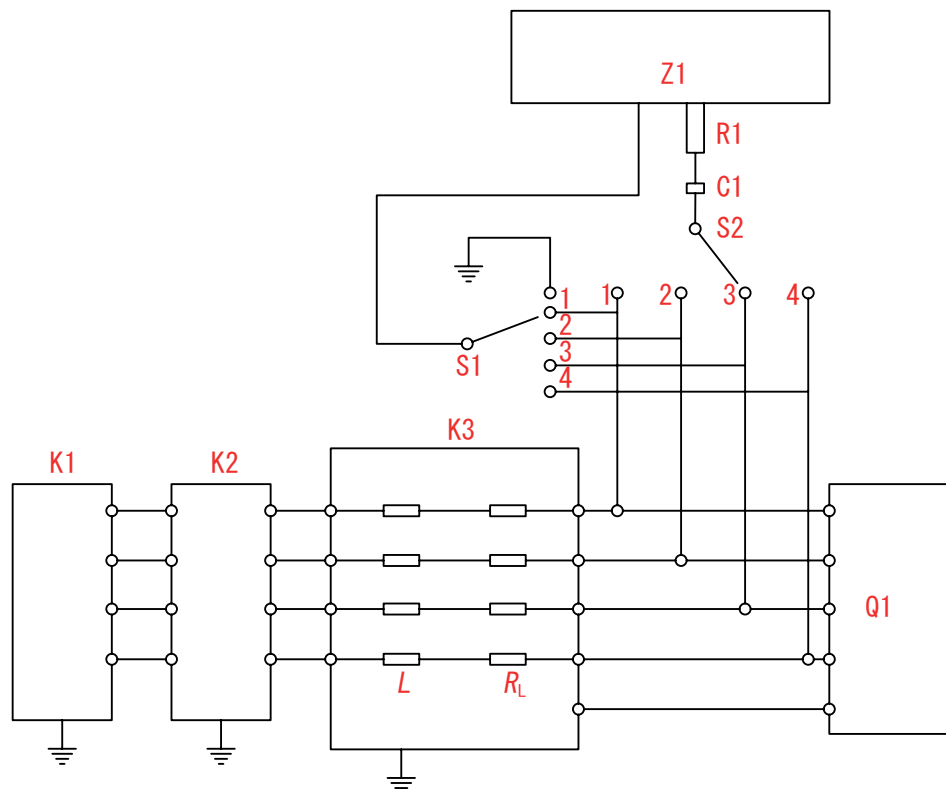

**Key**

- C1 capacitor with capacitance of 0,5  $\mu$ F
- K1 auxiliary equipment
- K2 protection equipment
- K3 decoupling network
- L inductor (L = 20 mH)
- Q1 equipment under test
- R1 resistor with resistance of 40  $\Omega$
- RL resistive part of inductor L
- S1 switch (line to earth: position 0; line to line: positions 1 to 4)
- S2 switch
- Z1 combination wave generator

**Figure 1 — Example of surge immunity test circuit**

**5.16.2.4 Final measurements**

After the conditioning, measure the response point as specified in ISO 7240-10:2012, 5.1.5.

Designate the greater of the response points measured in this test and that measured for the same specimen in the reproducibility test as  $D_{max}$  and the lesser as  $D_{min}$ .

**5.16.3 Requirements**

No alarm or fault signals shall be given during the conditioning. No degradation or loss of function or performance as defined in the manufacturer’s technical specification shall occur.

The ratio of the response points,  $D_{max}: D_{min}$ , shall not be greater than 1,26.

## 5.17 Radiated emission

### 5.17.1 Object of test

The object of the test is to measure any signals radiated by an equipment which can potentially disturb other equipment.

### 5.17.2 Test procedure

#### 5.17.2.1 Reference

The test procedure as specified in CISPR 16-1 and CISPR 16-2 shall be performed.

#### 5.17.2.2 State of the specimen during conditioning

During the test, the equipment under test is operated at its rated operational voltage  $U_e$ .

Radiated emission from enclosure ports are specified in [Table 8](#).

**Table 8 — Radiated emission from enclosure ports**

Site	Frequency range	Limits
Bridge and deck zone — EMC1	150 kHz to 300 kHz	80 dB $\mu$ V/m to 52 dB $\mu$ V/m
	300 kHz to 30 MHz	52 dB $\mu$ V/m to 34 dB $\mu$ V/m
	30 MHz to 2 GHz	54 dB $\mu$ V/m
	Except for 156 MHz to 165 MHz	24 dB $\mu$ V/m
General power distribution zone — EMC2	150 kHz to 30 MHz	80 dB $\mu$ V/m to 50 dB $\mu$ V/m
	30 MHz to 100 MHz	60 dB $\mu$ V/m to 54 dB $\mu$ V/m
	100 MHz to 2 GHz	54 dB $\mu$ V/m
	Except for 156 MHz to 165 MHz	24 dB $\mu$ V/m

#### 5.17.2.3 General instruction

The radiation limit at distance 3 m from the enclosure port over the frequency ranges shall be measured.

The quasi-peak measuring receivers specified in CISPR 16-1 shall be used. The receiver bandwidth in the frequency ranges 150 kHz to 30 MHz and 156 MHz to 165 MHz shall be 9 kHz, and in the frequency ranges 30 MHz to 156 MHz and 165 MHz to 2 GHz shall be 120 kHz.

For frequencies from 150 kHz to 30 MHz, measurements shall be made of the magnetic H-field.

The correction factor for the antenna shall include the factor +51,5 dB to convert the magnetic field strength to equivalent electric field strength.

For frequencies above 30 MHz, measurements shall be made of the magnetic E-field.

The test antenna shall be placed at a distance of 3 m from the EUT. The centre of the antenna shall be at least 1,5 m above the ground plane.

The E-field antenna shall be adjusted in height and the EUT shall be placed at the mid-point of a plane orthogonal to the test antenna and be rotated to achieve the maximum emission level.

5.17.3 Requirements

The radiation limit from the enclosure port shall not exceed the limits shown in [Figure 2](#).

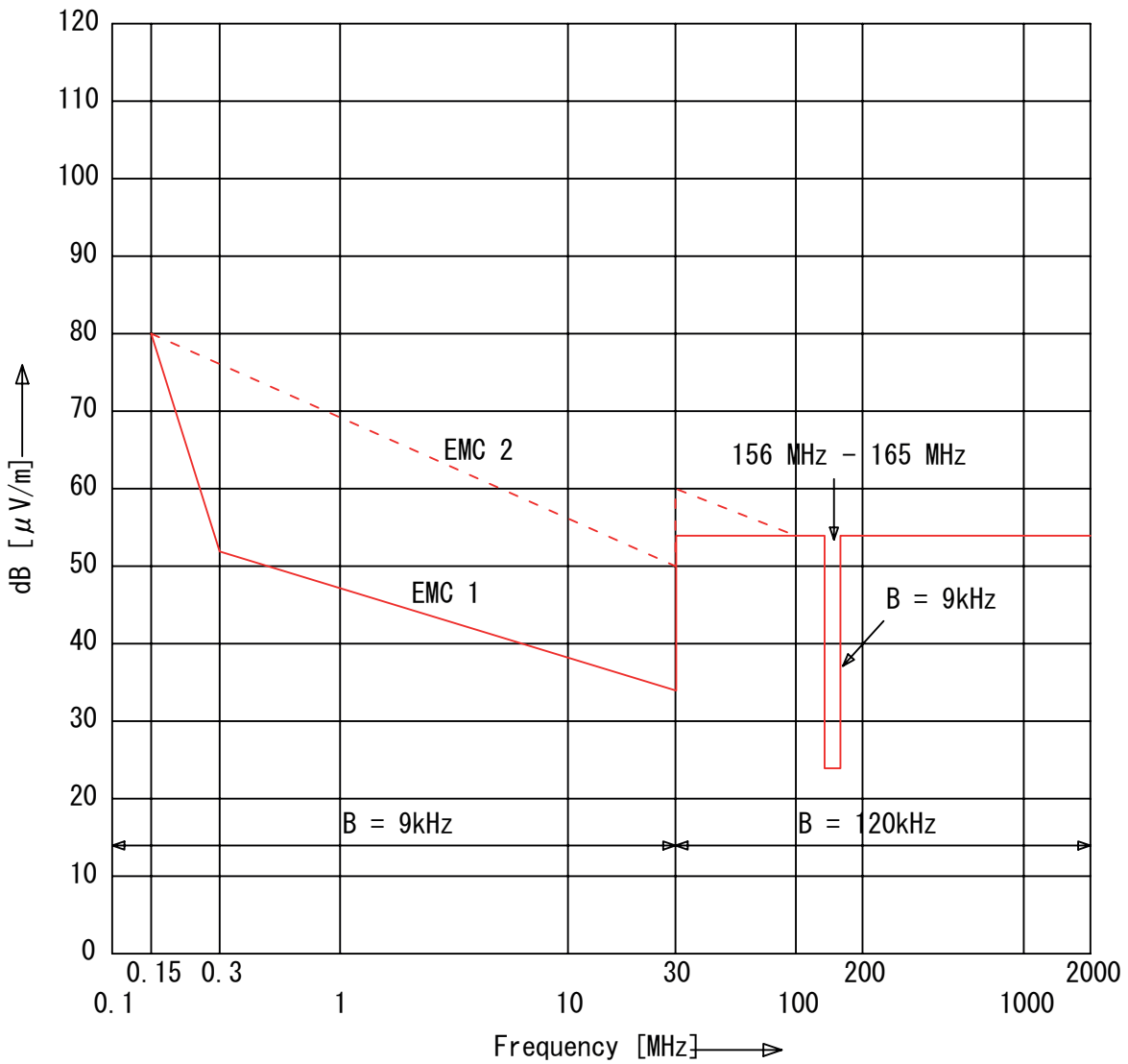

Key

B measuring receiver bandwidth

EMC1 bridge and deck zone

EMC2 general power distribution zone

NOTE Field strength E measured at 3 m.

Figure 2 — Limit values for radiated emissions from enclosure ports



## Bibliography

- [1] IEC 60092-504, *Ed. 3.0:2001 Electrical installations in ships — Part 504: Special features — Control and instrumentation* International
- [2] IEC/PAS 60092-510:2009, *Electrical installations in ships — Special features — High Voltage Shore Connection Systems (HVSC-Systems)*

