**Road vehicles — Connection interface
for pyrotechnic devices, two-way
and three-way connections —**

**Part 1:
Pocket interface definition**

*Véhicules routiers — Interface de raccordement pour dispositifs
pyrotechniques, deux voies et trois voies —*

Partie 1: Définition de l'interface du support allumeur



Reference number
ISO 19072-1:2007(E)

© ISO 2007

PDF disclaimer

This PDF file may contain embedded typefaces. In accordance with Adobe's licensing policy, this file may be printed or viewed but shall not be edited unless the typefaces which are embedded are licensed to and installed on the computer performing the editing. In downloading this file, parties accept therein the responsibility of not infringing Adobe's licensing policy. The ISO Central Secretariat accepts no liability in this area.

Adobe is a trademark of Adobe Systems Incorporated.

Details of the software products used to create this PDF file can be found in the General Info relative to the file; the PDF-creation parameters were optimized for printing. Every care has been taken to ensure that the file is suitable for use by ISO member bodies. In the unlikely event that a problem relating to it is found, please inform the Central Secretariat at the address given below.



COPYRIGHT PROTECTED DOCUMENT

© ISO 2007

All rights reserved. Unless otherwise specified, no part of this publication may be reproduced or utilized in any form or by any means, electronic or mechanical, including photocopying and microfilm, without permission in writing from either ISO at the address below or ISO's member body in the country of the requester.

ISO copyright office
Case postale 56 • CH-1211 Geneva 20
Tel. + 41 22 749 01 11
Fax + 41 22 749 09 47
E-mail copyright@iso.org
Web www.iso.org

Published in Switzerland

Foreword

ISO (the International Organization for Standardization) is a worldwide federation of national standards bodies (ISO member bodies). The work of preparing International Standards is normally carried out through ISO technical committees. Each member body interested in a subject for which a technical committee has been established has the right to be represented on that committee. International organizations, governmental and non-governmental, in liaison with ISO, also take part in the work. ISO collaborates closely with the International Electrotechnical Commission (IEC) on all matters of electrotechnical standardization.

International Standards are drafted in accordance with the rules given in the ISO/IEC Directives, Part 2.

The main task of technical committees is to prepare International Standards. Draft International Standards adopted by the technical committees are circulated to the member bodies for voting. Publication as an International Standard requires approval by at least 75 % of the member bodies casting a vote.

ISO 19072-1 was prepared by Technical Committee ISO/TC 22, *Road vehicles*, Subcommittee SC 3, *Electrical and electronic equipment*.

ISO 19072 consists of the following parts, under the general title *Road vehicles — Connection interface for pyrotechnic devices, two-way and three-way connections*:

- *Part 1: Pocket interface definition*
- *Part 2: Test methods and general performance requirements*

Introduction

Road vehicles integrate an increasing number of pyrotechnic devices contributing to occupant safety in vehicles, e.g. frontal and side air bag, safety belt pretensioner.

Various pocket definitions currently exist all over the world, a situation which is proving problematic for the different equipment makers. The goal of this part of ISO 19072 is therefore to define a common specification.

Annex A defines a sealed option of the pyrotechnic device/initiator harness connector assembly.

Annex B defines a variant without retainer of the pyrotechnic device/initiator harness connector assembly.

The International Organization for Standardization (ISO) draws attention to the fact that it is claimed that compliance with this document may involve the use of patents DE19939407, EP-B-1079474 and US-A-6,402,640.

ISO takes no position concerning the evidence, validity and scope of this patent right.

The holder of this patent right has assured ISO that he is willing to negotiate licences under reasonable and non-discriminatory terms and conditions with applicants throughout the world. In this respect, the statement of the holder of this patent right is registered with ISO. Information may be obtained from:

FCI
145, rue Yves Le-Coz
78000 Versailles
France

Attention is drawn to the possibility that some of the elements of this document may be the subject of patent rights other than those identified above. ISO shall not be held responsible for identifying any or all such patent rights.

Road vehicles — Connection interface for pyrotechnic devices, two-way and three-way connections —

Part 1: Pocket interface definition

1 Scope

This part of ISO 19072 defines a common specification of the pyrotechnic device pocket interface. It also defines a sealed variant of the design.

2 Normative references

The following referenced documents are indispensable for the application of this document. For dated references, only the edition cited applies. For undated references, the latest edition of the referenced document (including any amendments) applies.

ISO 8092-2, *Road vehicles — Connections for on-board electrical wiring harnesses — Part 2: Definitions, test methods and general performance requirements*

ASTM B488, *Standard Specification for Electrodeposited Coatings of Gold for Engineering Uses*

ASTM B735, *Standard Test Method for Porosity in Gold Coatings on Metal Substrates by Nitric Acid Vapor*

3 Terms and definitions

For the purposes of this document, the terms and definitions given in ISO 8092-2 and the following apply.

3.1

connector

assembly used to connect several conductors together or a single conductor to an appliance

NOTE A male (female) connector is a housing containing male (female) contacts and accessory items. A male connector can be permanently fixed to a wiring harness or to an appliance, e.g. an electronic control unit (ECU). A female connector is generally permanently fixed to a wiring harness.

3.2

housing

connector without its contacts

3.3

retainer

ring holding a shunt and providing coding and electrical insulation, generally made of plastic

3.4

squib holder

part of the pyrotechnic device, holding the initiator and the retainer

3.5

pocket

squib holder inner interface including male contacts

3.6

initiator

part of the pyrotechnical device holding the two male contacts

4 Dimensional features of squib holder interface including male contacts

The contact and short-circuit areas when male and female connectors are mated shall comply with Figure 1.

5 Material characteristics of contact and short-circuit areas of pins

Pin plating shall comply with the following characteristics:

- ASTM B488, type (coating purity) and class (coating thickness) to be agreed between customer and supplier, but not less than class 0,5;
- ASTM B735, porosity max. 2 pores/mm²;
- under layer material: nickel $\geq 1 \mu\text{m}$.

Dimensions in millimetres

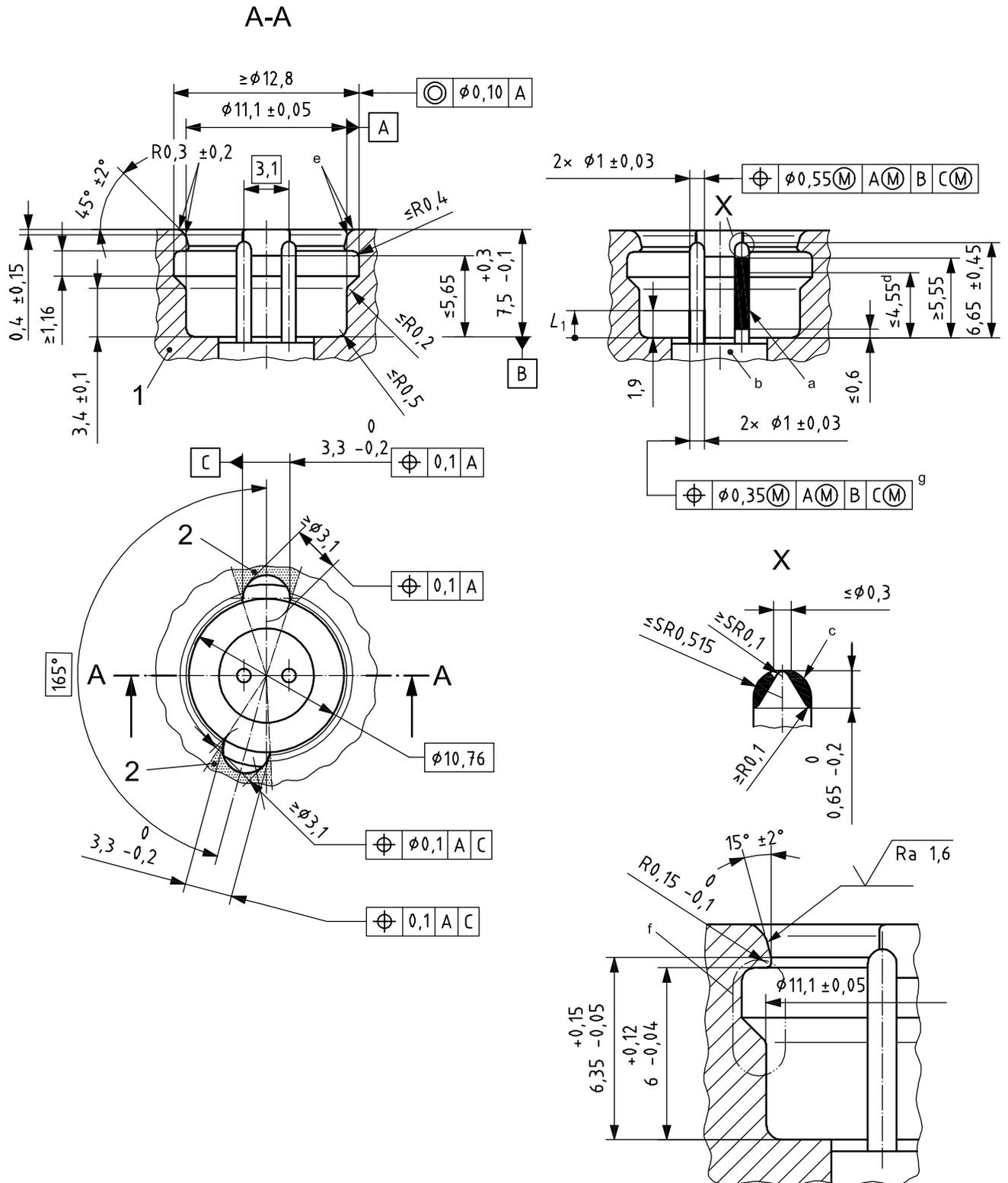

Key

- 1 squib holder
- 2 area in which any shape guaranteeing polarisation is acceptable

ISO 19072-1:2007(E)

- a Minimum plating contact and short-circuit areas in accordance with Clause 5; plating extends to the tip of the pin.
- b Any shape accepted where surface of initiator is flush with or below datum B and satisfies the connector/retainer function requirement.
- c Any convex or straight shape inside shaded area accepted at top of pin; smooth and burr free.
- d Maximum contact point; the female contact guarantees a minimum overlap of 1 mm in the contact area.
- e Rounded and burr free.
- f Undercut geometry is required to hold the connector and retainer inside the squib holder.
- g This dimension concerns only the length L_1 .

NOTE 1 Datum C depends on the style of the polarisation area (hole or slot).

NOTE 2 In the noted area, the undercut surface meets the dimensions as specified on this figure, but does not need to be a continuous 360° surface; it also meets the specified connector and retainer retention requirements and dimensions regardless of material.

Figure 1 — Squib holder interface with male contacts

Annex A (normative)

Sealed variant

Clauses 1 to 5 apply in their entirety for the sealed design.

For sealed connectors, a seal is inserted between the squib holder and the connector. The space to be left free for the seal shall comply with Figure A.1.

Dimensions in millimetres

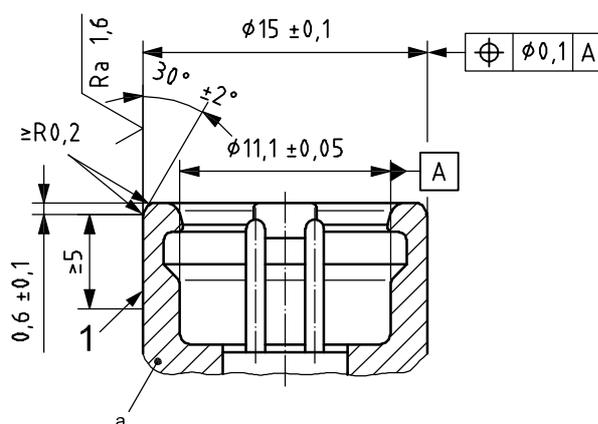

Key

- 1 surface reserved for sealing
- a All shapes accepted.

Figure A.1 — Sealing

Annex B (normative)

Variant without retainer of the pyrotechnic device/initiator harness connector assembly

Clauses 1 to 5 apply in their entirety for the design without retainer.

Without retainer, only the anti-rotational feature can exceed the squib holder bottom. The initiator and connector shall comply with Figure B.1.

Dimensions in millimetres

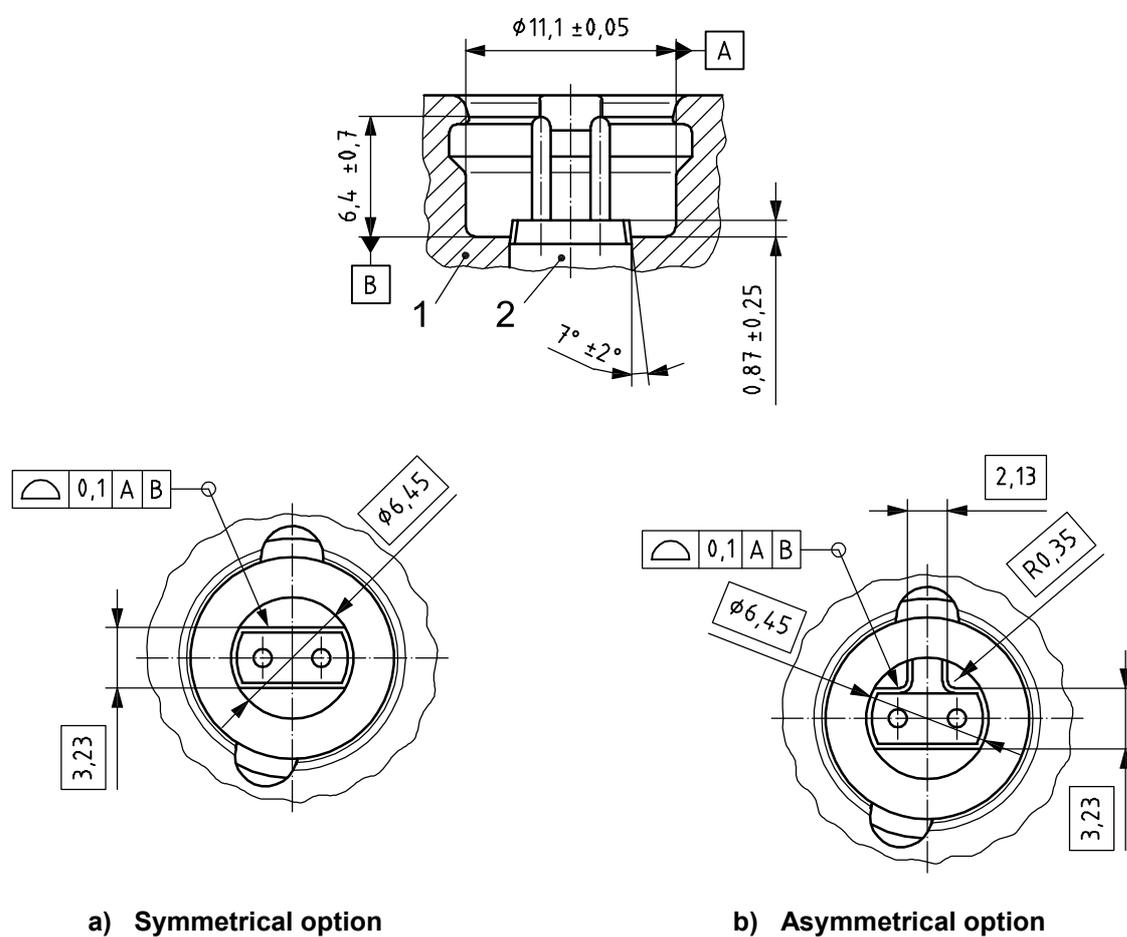

Key

- 1 squib holder as defined in Figure 1
- 2 anti-rotational feature for symmetrical and asymmetrical option

Figure B.1 — Pocket interface with male contacts

ICS 43.040.10

Price based on 6 pages