

---

---

**Accessible design — Information  
contents, figuration and display  
methods of tactile guide maps**

*Conception accessible — Sommaire des informations, méthodes de  
figuration et d'affichage des plans de guide tactile*



**COPYRIGHT PROTECTED DOCUMENT**

© ISO 2016, Published in Switzerland

All rights reserved. Unless otherwise specified, no part of this publication may be reproduced or utilized otherwise in any form or by any means, electronic or mechanical, including photocopying, or posting on the internet or an intranet, without prior written permission. Permission can be requested from either ISO at the address below or ISO's member body in the country of the requester.

ISO copyright office  
Ch. de Blandonnet 8 • CP 401  
CH-1214 Vernier, Geneva, Switzerland  
Tel. +41 22 749 01 11  
Fax +41 22 749 09 47  
copyright@iso.org  
www.iso.org

# Contents

Page

<b>Foreword</b> .....	<b>iv</b>
<b>Introduction</b> .....	<b>v</b>
<b>1 Scope</b> .....	<b>1</b>
<b>2 Normative references</b> .....	<b>1</b>
<b>3 Terms and definitions</b> .....	<b>1</b>
<b>4 Information contents to be displayed on tactile guide maps</b> .....	<b>2</b>
<b>5 Figuration of tactile guide maps</b> .....	<b>3</b>
<b>6 Display methods</b> .....	<b>6</b>
<b>7 Materials used for tactile guide maps</b> .....	<b>12</b>
<b>Annex A (informative) Japanese examples of tactile marks</b> .....	<b>14</b>
<b>Annex B (informative) German examples of tactile marks</b> .....	<b>18</b>
<b>Annex C (informative) Swedish examples of tactile marks</b> .....	<b>26</b>
<b>Bibliography</b> .....	<b>30</b>

## Foreword

ISO (the International Organization for Standardization) is a worldwide federation of national standards bodies (ISO member bodies). The work of preparing International Standards is normally carried out through ISO technical committees. Each member body interested in a subject for which a technical committee has been established has the right to be represented on that committee. International organizations, governmental and non-governmental, in liaison with ISO, also take part in the work. ISO collaborates closely with the International Electrotechnical Commission (IEC) on all matters of electrotechnical standardization.

The procedures used to develop this document and those intended for its further maintenance are described in the ISO/IEC Directives, Part 1. In particular the different approval criteria needed for the different types of ISO documents should be noted. This document was drafted in accordance with the editorial rules of the ISO/IEC Directives, Part 2 (see [www.iso.org/directives](http://www.iso.org/directives)).

Attention is drawn to the possibility that some of the elements of this document may be the subject of patent rights. ISO shall not be held responsible for identifying any or all such patent rights. Details of any patent rights identified during the development of the document will be in the Introduction and/or on the ISO list of patent declarations received (see [www.iso.org/patents](http://www.iso.org/patents)).

Any trade name used in this document is information given for the convenience of users and does not constitute an endorsement.

For an explanation on the meaning of ISO specific terms and expressions related to conformity assessment, as well as information about ISO's adherence to the WTO principles in the Technical Barriers to Trade (TBT) see the following URL: [Foreword - Supplementary information](#)

The committee responsible for this document is ISO/TC 173, *Assistive products for persons with disability*, Subcommittee SC 7, *Accessible design*.

## Introduction

As the number of older population and social participation of persons with disabilities is increasing, the improvement of the social infrastructure for these people is an urgent issue. Devices for mobility assistance to facilitate social participation of persons with seeing impairment and blindness have rapidly disseminated. Among others, a tactile guide map is a convenient tool for providing location information which is necessary for mobility of such people. Although the number of their installation has steadily increased, it has become obvious that, in the meantime, inappropriate or misleading tactile guide maps have been increasing, which has caused the users a big problem. To solve the problem, this International Standard provides the principal and standardized specifications concerning information contents, figuration and display methods of tactile guide maps.



# Accessible design — Information contents, figuration and display methods of tactile guide maps

## 1 Scope

This International Standard specifies information contents, figuration and display methods of tactile guide maps providing location information of buildings, including those for the general public, public transport and parks, and also the surroundings in the close vicinity, including access routes to them in order to enable persons with seeing impairment and blindness to move safely and smoothly in those facilities.

## 2 Normative references

The following documents, in whole or in part, are normatively referenced in this document and are indispensable for its application. For dated references, only the edition cited applies. For undated references, the latest edition of the referenced document (including any amendments) applies.

ISO 17049, *Accessible design — Application of braille on signage, equipment and appliances*

ISO 21542:2011, *Building construction — Accessibility and usability of the built environment*

## 3 Terms and definitions

For the purposes of this document, the following terms and definitions apply.

### 3.1

#### **tactile guide map**

information map that provides persons with seeing impairment and blindness with location information of inside and outside of buildings including those for the general public, public transport and parks, which is made recognizable using, for example, convex (raised) lines and/or convex or concave (engraved) surfaces, *tactile marks* (3.6), braille and/or *raised characters* (3.10), and/or large print, having two types: an installed type in facilities, etc. and a portable booklet format

### 3.2

#### **title**

concise text in braille and/or *raised characters* (3.10) indicating the content of a *tactile guide map* (3.1)

### 3.3

#### **commentary**

information in braille and/or *raised characters* (3.10) to give general description of a *tactile guide map* (3.1), cautions and usage of *tactile marks* (3.6)

### 3.4

#### **lettering**

letters, numbers, words, or a combination of them to label items of interest in a *tactile guide map* (3.1)

### 3.5

#### **legend**

index with explanation of *tactile marks* (3.6) and/or abbreviations of braille, and/or *raised characters* (3.10) used for *tactile figures* (3.7)

**3.6**

**tactile marks**

convex or concave marks used for a *tactile guide map* (3.1) to provide information on facilities and equipment

**3.7**

**tactile figure**

aggregated relief-like figure composed of convex lines and/or convex or concave surfaces, *tactile marks* (3.6), braille and/or *raised characters* (3.10)

**3.8**

**printed characters**

characters written in pencil, with a pen, and in print, not in Braille

**3.9**

**large print**

letters with high readability for people with residual vision

**3.10**

**raised characters**

specially designed raised/embossed characters composing letters and numbers readable by touch

**3.11**

**tactile readability**

ease of reading braille and other tactile information by touch

[SOURCE: ISO 17049:2013, 2.5]

**3.12**

**pictogram**

graphical composition that may include a symbol plus other graphic elements, such as a border, background pattern or colour that is intended to convey specific information

[SOURCE: ISO 17840-1:2015, 2.14]

**3.13**

**tactile walking surface indicator**

**TWSI**

standardized walking surface used for information by persons with seeing impairment and blindness

## **4 Information contents to be displayed on tactile guide maps**

### **4.1 Composition of a tactile guide map**

A tactile guide map shall be composed of the following contents:

a) title;

b) commentary;

A commentary can be omitted when a tactile guide map does not need any description of the content. For a tactile map in a booklet form, a commentary may be placed separately.

c) legend;

A legend can be omitted if a tactile guide map only contains common and easily recognizable tactile marks without need of explanation and does not use abbreviations in braille and raised characters.

d) tactile figures;



e) other information contents:

1) scale;

When appropriate, to facilitate navigation, a scale to indicate distances in the map should be added.

2) north direction.

When appropriate, north direction should be indicated.

## 4.2 Principles for information contents

**4.2.1** Tactile guide map shall be confined to the minimum information required to grasp the locality and/or path of travel.

The amount of information given in a tactile guide map will largely be determined by the purpose of the tactile map. The information given differs whether the map is for indicating a route of travel or to give an overview of an area. All information that does not serve the intended purpose of the tactile guide map shall be omitted.

**EXAMPLE** The information of the number of steps in each stairway is often given in the “orientation and mobility maps”, which are specialized for training of the persons with seeing impairment and blindness, while in the common tactile maps, such information is usually omitted.

**4.2.2** When selecting information to be displayed on the map, the contents which support safe and smooth movements of persons with seeing impairment and blindness shall be prioritized.

**4.2.3** Tactile readability shall be considered of prior consideration.

The tactile readability of tactile information in guide maps is influenced by a variety of factors, which shall be considered in their mutual interdependence, which, in turn, will widely influence the selection, size and shape of tactile figures and marks.

When a visual guide map displaying the identical range to a tactile guide map is available, the maps shall maintain mutual consistency, though the amount of information may be different.

**4.2.4** All types of tactile marks (whether tactile figures or lettering) contained in a tactile guide map shall be easily identifiable and be explained in the legend or by lettering in the respective area of the map.

**4.2.5** Pictograms commonly used for sighted people in technical drawings or in wayfinding signage shall be avoided because they are too complicated and finely structured to be read by finger touch.

**4.2.6** Printed characters may be also used along with tactile figures on a tactile guide map.

**4.2.7** Instead of lettering points of installed guide maps, electronic tags giving out audio information about the particular points in the map can be used.

**4.2.8** The date of production and the contact information should be displayed.

## 5 Figuration of tactile guide maps

### 5.1 Dimensions

The physical size of a tactile guide map shall correlate with the amount of information required for the purpose to be achieved by the tactile guide map in relation to the size of the location or area to be depicted in the map.

The size of an installed tactile guide map should be within 600 mm in grip distance for desk installation (see [Figure 1](#)) and for wall installation (see [Figure 2](#)). When a tactile guide map is prepared in a booklet form, extra attention should be paid so that the folds do not hinder tactile reading.

## 5.2 Location of installed tactile guide maps

For a tactile guide map installed on the wall, which is perpendicular to the floor, the centre line height should be preferably 1 400 mm from the floor level.

These dimensions do not apply to guide maps which are set horizontally to the floor or inclined to angles close to horizontal installation (see [Figure 1](#)). In either case, a location that does not hinder tactile readability shall be chosen.

The clearance of the lowest part of the desk installation shall be 900 mm to enable wheelchair users to access. See ISO 21542:2011, 40.14.

Great care shall be taken to ensure that people with seeing impairment and blindness can find the installed tactile guide maps, e.g. by using tactile walking surface indicator (TWSIs) or similarly appropriate tactile guidance and/or audio guidance to lead them there or by installing floor plans at fixed places next to elevators, stairs, etc.

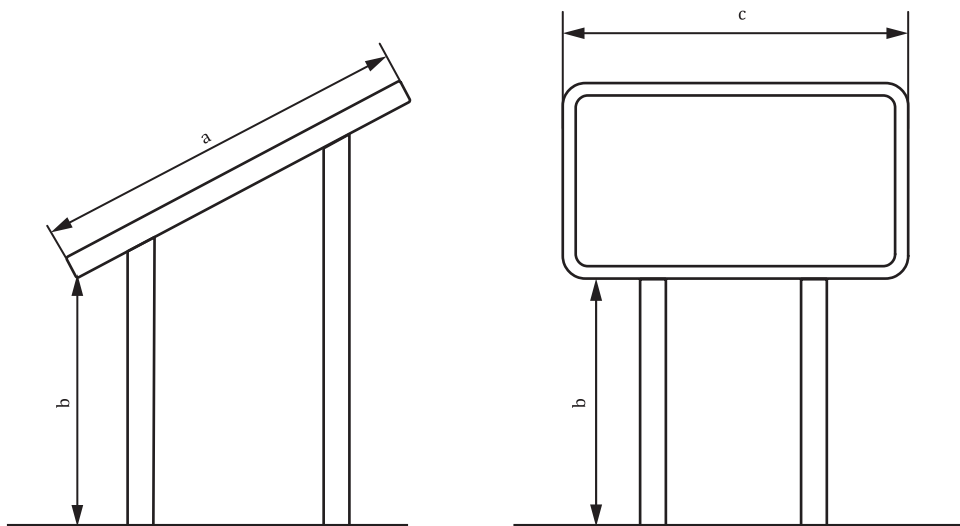

- a Within 600 mm.
- b 900 mm.
- c Approximately 1 000 mm.

**Figure 1 — Examples of figurations of desk installation type**

When deciding the height of installation, the target group for a particular map should be taken in consideration, which may lead to other decisions concerning installation height of the map (e.g. when the target group are children).

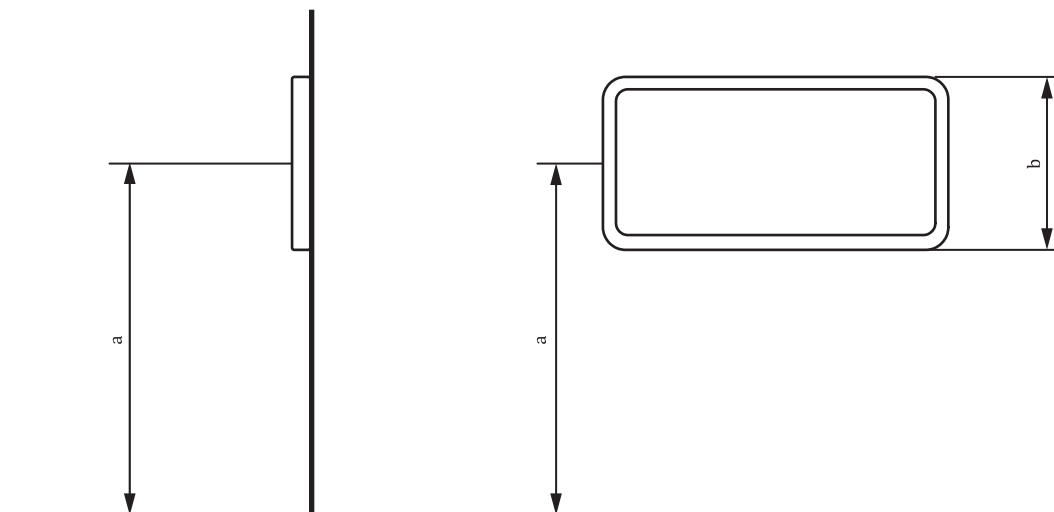

a Preferably 1 400 mm.

b Within 600 mm.

NOTE The frames of tactile guide maps are not included in the given measures of tactile maps.

**Figure 2 — Examples of figurations of wall installation type**

### 5.3 Directions of a tactile guide map

**5.3.1** When installing a guide map, marks of directional reference and present location indicated in a tactile guide map shall strictly comply with the actual directions and present location in the place where the map is to be installed. For example, locations of a particular office depicted in the map to the right-hand side in a building shall be found on the right-hand side of the actual building.

NOTE When tactile guide maps are placed at an angle (e.g. 180° or any other angle to the actual directions), blind people face problems since they cannot see other landmarks as, e.g. flights of stairs, lifts, etc., which would enable them to adjust the faulty direction given in the map. Some people have difficulties in turning the map round in the mind.

**5.3.2** Tactile guide maps for installation shall be placed in the way that a user can read the lettering and tactile figures well.

**5.3.3** For guide maps which contain information on spatially overlapping area, such as the first floor and the second floor of a building, and guide maps which display one large space using multiple maps, the scale size and the direction shall be unified. When the maps of each floor are to be installed on respective floors, each guide map should be placed in the same location of respective floors and in the same direction.

Presenting two levels of a building or a place on top of each other in one tactile guide map is not permissible, because the elements to each level cannot be assigned by the blind reader unambiguously. If in a multi-storey building, several storeys should be displayed for reason of different layout of rooms or for information on rooms, separate individual maps for each storey are required. If needed, a cross section in side view of the building could be added, comprising several storeys to indicate transfer routes from one storey to another, different room arrangements, halls rising over more than one storey, etc.

**5.3.4** Tactile guide maps in a booklet form may employ user-friendly directions, considering locations of doorways, flow-lines and so on.

**5.3.5** The starting position should be clearly indicated by a big dot or triangular sign.

## **6 Display methods**

### **6.1 General**

The display method will result from the purpose and the type of the tactile guide map, whether it is a sketch only, a portable map in a booklet, or whether it is a map installed indoors or outdoors or it is a model of a site (e.g. a building, an access route to a place, or an overview of a place, such as of a park or a garden).

To represent a large, complex building, the vicinity or park area around a building or a clear floor plan will require a different amount of information and hence, a different scale. Decisions to apply tactile figures or only marks should be made in accordance with the space available in the tactile map and the necessity to provide additional information for guiding or orientation (the need to give part of a path of travel in an extended scale, e.g. complex crossroads) or directions of stairs (e.g. going upward or downward), giving directions of a lift (when going to different parts of a building, etc.).

### **6.2 Title**

A title shall be displayed in the upper part of a tactile guide map.

### **6.3 Commentary**

Commentary should be placed close to the title or the legend.

### **6.4 Legend**

**6.4.1** The legend shall be placed where it can be easily understood, and when the legend comprises only of a few items, it should be preferably located to the left of tactile figures or the upper part of a map under the title. A legend clearly delimited by a line can be placed in the area of the map, where irrelevant parts of the original maps are cancelled. Commentary and a legend for maps in a booklet form can be combined and put in another page. A legend in a booklet type should not be placed on the back side of the map itself.

**6.4.2** The display of a legend shall be in the order of displaying “tactile marks” first and then “abbreviations of braille” in alphabetical order. Tactile marks shall be displayed in order of importance. When raised characters are used, they should be located left to the tactile marks and braille should be located right to the tactile marks. The display order of abbreviations of braille and/or raised characters shall be in alphabetical order. For installed maps, tactile marks of the present location should be the first item to be displayed.

**6.4.3** The dimensions and shapes of tactile marks displayed in the legend and the ones used as part of tactile figures in the map shall not be different, but dimensions, such as width of stairs, may deviate in accordance with the actual location/position of the map.

**6.4.4** Corresponding braille, abbreviations and tactile figures should be easily recognizable.

### **6.5 Present location and additional guiding information within the map**

**6.5.1** The tactile mark of the present location/starting point should be expressed higher than other marks in dome shape or triangle shape. Braille should be placed adjoining to the mark as near as possible (see [Annex A](#), EXAMPLE 1; [Annex C](#), EXAMPLE 8).

**6.5.2** In tactile guide maps, the present location shall be the most prominent mark in the map since it is the starting point for the user to organize orientation in the map. The starting point in the booklet type should be treated the same way as the present location in the installed type.

**6.5.3** For an installed guide map, the present location in the tactile figures shall be explained in the commentary or in the legend.

**6.5.4** The present location and destinations, such as other installation sites of the tactile guide map, should be explained by using a combination of the horizontally and vertically trisected area (see [Figure 3](#)) or by using coordinates (see [Figure 4](#)).

**6.5.5** For explaining the location by coordinates, tactile frames with notches can be used as graduations on axes with associated numbers or letters. Notches shall have an edge that will not cause harm when touched (see [Figure 4](#)).

upper left	upper middle	upper right
left	center	right
lower left	lower middle	lower right

NOTE The location expressed by a bullet in [Figure 3](#) is explained as “lower middle”.

**Figure 3 — Example of trisected area**

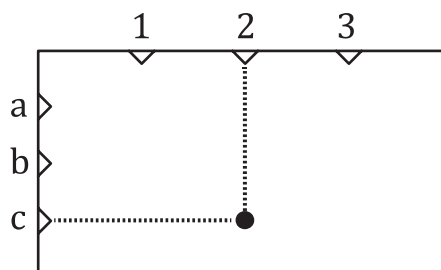

**Key**

- 1 one-fourth of the horizontal distance from the left
- 2 horizontal centre
- 3 one-fourth of the horizontal distance from the right
- a one-fourth of the vertical distance from the top
- b vertical centre
- c one-fourth of the vertical distance from the bottom

NOTE The location expressed by a bullet in [Figure 4](#) is explained as c2.

**Figure 4 — Example of coordinates**

**6.5.6** When the location of other tactile guide maps which provide further guiding information is within the area of the map or close to it, such information points/maps shall be indicated in the map by a special tactile mark shaped like a long dot (see Annex B, EXAMPLE 3) and, when outside the actual map, the mark shall be placed in the margin with an arrow to indicate its direction where to find it.

## **6.6 Tactile figures**

### **6.6.1 Principles of tactile figures**

**6.6.1.1** In order to prioritize tactile readability, tactile figures can be modified and transformed and do not need to be proportional to actual sites.

**6.6.1.2** In tactile guide maps, important building components, such as stairs, escalators, elevators and toilets or landmark facilities, can be raised more than other places or highlighted by increasing the density of patterns so that the map may be more understandable.

### **6.6.2 Shapes and elevation of tactile figures**

**6.6.2.1** Tactile figures in guide maps, such as tactile marks, letters and numbers, should be used sparingly in favour of greater clarity and the usage of bigger, more self-explaining (intuitively recognizable) tactile figures.

**6.6.2.2** The minimal elevation of raised surfaces of tactile figures and marks shall be 0,5 mm except very smooth surfaces are available for tactile guide maps. In that case, single lines and clearly structured tactile marks may be reduced to a height of elevation of 0,3 mm at a minimum.

**6.6.2.3** When, however, in complex places (e.g. a large entrance hall to a building, such as a conference centre, a railway station, an arrival or departure hall of an airport, etc.), higher levels of elevation than 0,5 mm may be needed.

**6.6.2.4** Non-accessible areas, such as off-limits lawns and ponds in parks, shall be specified by tactile figures.

**6.6.2.5** The location of building entrances and room doorways shall be displayed clearly.

**6.6.2.6** Spatially overlapping spaces, such as the first floor and the second floor, shall be displayed separately.

## **6.7 Tactile marks**

### **6.7.1 Principles of tactile marks**

**6.7.1.1** In one tactile guide map, the use of similar tactile marks in different meanings shall be avoided.

**6.7.1.2** Tactile marks are usually convex in tactile maps and not concave. Convex marks are much easier to recognize tactually than concave marks. Therefore, the latter marks need more attention and care when used in tactile guide maps.

**6.7.1.3** In tactile guide maps, concave expressions may be used. Expressing rivers or ponds, which are actually lower than other places, makes the map sometimes more understandable. The road between buildings can be expressed lower than buildings for better understanding. However, the road may be expressed in a convex line when the scale is large enough and the road is of major importance.

**6.7.1.4** When constructing a tactile figure, lines, surface and other tactile marks that are easy to recognize by touch shall be used effectively. Attention shall be paid not to hinder tactile readability by displaying an excessive number of variation in marks.



**6.7.1.5** For displaying a variety of facilities by tactile lines, such as outlines of buildings, tactile walking surface indicators, pathways in parks and roads, the differences shall be easily recognizable and distinguished by straight, dotted and dashed lines.

**6.7.1.6** When there is sufficient space in a tactile map, self-explaining profiled tactile marks should be preferred. However, there shall be no mixture of marks in the same tactile map referring to the same item (e.g. stairs, escalator, elevator, etc.).

**6.7.1.7** Since many tactile guide maps are produced from floor plans or technical drawings, great attention should be paid to the fact that many tactile marks are transferred or derived from those sources. Such signage of sighted people (e.g. the signage showing stairs going upward or downward) are often very abstract and too finely structured, as well as too complex to be employed in tactile maps for blind people. They shall be simplified by reducing or adapting that signage to clearly identifiable marks, which can be read by finger touch.

## **6.7.2 Information items to be observed in tactile marks**

### **6.7.2.1 Doorways of rooms**

When expressing the space partitioned by convex lines as a room, doorways are expressed by breaking a part of the line. When a broken part is long, the change of the space is sometimes unrecognized. Door blades can be indicated by short lines projecting into the direction the door opens. Around the entrance, the name of a room should be indicated in braille. When a room is narrow, an abbreviation in braille and/or raised characters can be used (see [Annex A](#), EXAMPLE 5).

### **6.7.2.2 Stairs/escalators/ramps**

In facilities which have differences in level, such as stairs, escalators, ramps, it is desirable to use marks identifiable whether upward or downward. Devised marks have v-shaped, triangle or tactile dot on a higher level (see [Annex A](#), EXAMPLES 3 and 4; [Annex B](#), EXAMPLES 5 and 6; [Annex C](#), EXAMPLES 6 and 16). In case of escalators, not only differences in level but also information on usable direction should be more desirable.

### **6.7.2.3 Marks to indicate non-accessible areas**

The total space can be conveyed by filling up the space with a dot pattern or stripe pattern (see [Annex A](#), EXAMPLE 6).

NOTE High-density dot pattern means the off-limit area, and low-density dot pattern means the lawn area.

### **6.7.2.4 Arrows to indicate directions**

Arrows can be used effectively to express directions or landmarks in the margin. The shape should be simply composed of arrows and arrow shafts, and the pointing lines should have an angle of 90° (see [Annex A](#), EXAMPLES 10 and 11).

### **6.7.2.5 Dotted lines to indicate TWSIs or travel rules**

Dotted lines are suitable to express TWSIs. When few dots are used, the attention should be paid to make differences between the distance and diameter of dots and the diameter of braille. Where there are no TWSIs, dot lines can be used to express guiding routes or as other lines (see [Annex A](#), EXAMPLE 2).

## 6.7.3 Shapes and elevation of tactile marks

### 6.7.3.1 Dots

In tactile guide maps, single dots should be used to indicate access points or points of special interest or importance. Such points should generally be labelled by a letter, a number or a tactile mark to distinguish them from each other.

- a) Labelled dots should be used in a tactile map to indicate points of interest, which will otherwise be difficult to indicate by tactile marks, like places where to rest in a park or garden (e.g. benches), access point to enter a swimming pool (e.g. a ladder), or a jetty at a river or a pond.
- b) In tactile guide maps, special points such as bus or tram stops, points where to get information, etc. should be indicated by dots. When a bus or tram line is indicated by a line in the road, tram stops should be indicated by small flat squares and bus stops by short lateral strokes (see [Annex B](#), EXAMPLES 16, 17 and 18; [Annex C](#), EXAMPLE 4).
- c) When in a tactile guide map a particular road crossing area needs to be depicted in an extended scale, the pedestrian crossing should be indicated by a double dot line with a wider distance between the dots (see [Annex B](#), EXAMPLE 22). The traffic lights could be indicated by a somewhat bigger dot.
- d) In a tactile map in a booklet format, a reference point (e.g. the starting position for a path of travel or the beginning of a description of a site) should be indicated by a bigger dot. Alternatively, an isosceles triangle with the elongated pointed tip could indicate the beginning and direction for travelling.

### 6.7.3.2 Lines

Lines in maps fulfil various functions. When several different functions need to be indicated, the thickness, diameter, volume and structure of the lines should be used, ranging from very thin, smooth, continuous lines to dotted lines for differently structure and/or iterated lines.

- a) In a floor plan, lines indicate inner walls for rooms with opening for doors. Door blades can be indicated by thin lines projecting at an angle of 45° in the direction the door opens, sliding doors by a double line (see [Annex B](#), EXAMPLES 12 and 13). The outer walls of the building may be indicated by more prominent or flattened wider line structures. Windows can be marked in such outer wall structures by very thin lines.
- b) In outdoor areas, such as parks or gardens, the close vicinities around buildings lines shall preferably be employed to indicate fences, enclosing walls or boundaries of any kind (see [Annex C](#), EXAMPLE 2).
- c) When TWSIs indicate an optimal path in a tactile guide map, a thin dotted line should be employed. Decision points, such as branching or turning points within the path of travel, can be indicated by small rough squares (see [Annex B](#), EXAMPLE 24). A path of travel in a tactile guide map that is not marked by TWSIs shall mainly be indicated by a fine dotted line. The dotted line should consist of groups of three to four dots to distinguish such lines from TWSIs guiding paths (see [Annex B](#), EXAMPLE 25).

### 6.7.3.3 Areas

Non-accessible areas, such as restricted areas in the buildings, off-limits lawns and ponds in parks, shall be shown as surface area specified by tactile figures, clearly differentiated.

In adjoining surfaces with different information and minimal levels, differences in heights should be taken into account.

- a) Platforms, terraces and alike shall be indicated by a raised area. Further marks (e.g. stairs, ramps, elevators, railing, etc.) can be added on top of such platform areas. Marking platform or terrace



edges by lines shall be avoided because such a line could suggest there is a fence or railing at the platform edge.

- b) In most cases, it will be sufficient to indicate built areas (whether blocks of housing or industrial areas) by flat elevated areas instead of marking the areas by lines only. If required, individual areas can be labelled.
- c) In a more extended scale, the representation of complex crossroads or longer streets with several uniform blocks in tactile street maps should be structured by some landmarks in order to facilitate orientation and guiding. More prominent or important buildings like town halls, churches, hospitals, monuments or alike should be shown in a top view shape or as a profile view; or alternatively, they can be labelled.
- d) When different areas in a garden or park (e.g. lawns, flower beds, ponds) need to be distinguished, such areas should be given a different surface structure (e.g. lawn: a rougher surface, flower beds: a surface with tiny dots, water: a wavy or straight lined surface — see [Annex B](#)).
- e) When TWSIs are represented in tactile guide maps, attention fields should be indicated by a dotted area. In very narrow scale maps, warning fields can be reduced to rougher surface areas labelled by letters or numbers, which shall be explained in the legend.
- f) When a surface contrast with different degrees of smoothness/roughness of structure are used to distinguish different areas (in a garden or park, e.g. lawn, ponds, flower beds, paths, etc.) no extra elevation for each area is required.

## 6.8 Braille and raised characters

**6.8.1** Braille employed as one of the characters in a tactile figure shall follow the specification described in ISO 17049. For displaying braille and/or raised characters as a part of tactile figure, readability of tactile marks shall not be obstructed.

**6.8.2** When braille and raised characters are used together, either one shall not obstruct the readability of the other.

**6.8.3** Braille and/or raised characters should be displayed horizontally in the tactile guide map; they shall not be placed diagonally, nor in curved or upside-down arrangement. However, when the names of streets follow the roads, those can be placed not horizontally. It should be placed horizontally if there is enough space in the map next to the road and it can be clearly assigned to the particular road.

**6.8.4** Braille and raised characters that explain a large area shall be placed inside the area. Single lead lines can be used when tactile marks are too close together and the information would otherwise get lost.

**6.8.5** Braille and/or raised characters to explain tactile marks should be in the same horizontal level with the space of 6 mm between them for attaining mutual good readability.

**6.8.6** When appropriate, words commonly used but different from printed characters can be used for explanation in braille and/or raised characters, without referring to a legend.

EXAMPLE 1 “Information” — “info”.

EXAMPLE 2 “Rest room”, “washroom”, “lavatory”, “toilet” — “WC”.

## **6.9 Braille and large print**

For people with a small residual vision, it will be helpful to display braille and tactile marks together with black large print and brightly coloured printed marks.

- a) When braille and large print are displayed by a set of layers, the upper one, the transparent sheet or board made of plastics on which braille and tactile marks are constructed, and the lower one, the base on which large print and coloured marks are exhibited, the marks on both layers shall be congruent in position when looking at them from the top. This can be attained by fixing both layers in a frame or a booklet.
- b) When braille and large print are on the same layer, special care should be taken for large print and coloured marks to withstand frequent reading by touch. When blurring of those prints necessitates regular maintenance, the two layer construction described in a) shall be employed.
- c) Tactile readability shall not be decreased by a printed map that is displayed on the same surface.
- d) In case of placing a tactile guide map along with a printed one, the layout, the contrast and the colour scheme shall be considered for accessibility of persons with low vision and persons with colour blindness.

## **6.10 Tactile emergency guide maps**

Tactile emergency guide maps shall meet the following additional requirements.

- a) Tactile emergency guide maps shall be simple and provide the most essential information, such as walls, passages, stairs, exit doors, a fire-resistant elevator, a safe shelter, etc., which shall be clearly named in the map. In case of a booklet type, the shortest route to the nearest emergency exit shall be highlighted and marked by a prominent, clearly perceptible guide line.
- b) Tactile emergency guide maps should be available in a joint tactile and visually readable format. This should make it easier for sighted people to assist persons with seeing impairment and blindness to interpret such maps when they face problems.
- c) Tactile emergency guide maps should be prepared in multi-language versions, at minimum, in a local language version and an English version.
- d) Tactile emergency guide maps should be available in a booklet type which can be mobile and read while sitting. Installed tactile emergency guide maps shall be placed where they can be easily found, e.g. next to the opening side of doors.
- e) Tactile emergency guide maps shall also contain emergency phone numbers and some major behavioural recommendations for emergency situations in braille and/or raised lettering, and large print.
- f) Separate tactile and visual versions of emergency maps should only be used when both versions are too different in sizes.

## **7 Materials used for tactile guide maps**

**7.1** Depending on the materials and technique applied to manufacture guide maps, the degree of fineness, precision, as well as the amount of information to be displayed can vary substantially. Materials that can produce fine and accurate structures, such as plastic hoils, hard plastic, bronze, etc., provide good tactile readability.

**7.2** Materials shall have good tactile readability and the surface shall not hurt fingers and hands of the readers.

**7.3** Materials should not have shining surfaces that could cause a glaring effect to the readers.

- 7.4** Materials should not get deteriorated and/or remarkably damaged by a long-term use.
- 7.5** Tactile guide maps should be cleaned regularly.
- 7.6** Materials should not get too hot and/or cold for the reader of the map to touch due to hot or cold weather environment.
- 7.7** The material used shall be selected so that no allergic reactions of the reader will result from it.



## Annex A (informative)

### Japanese examples of tactile marks

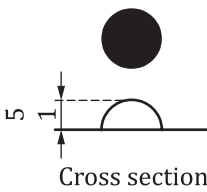
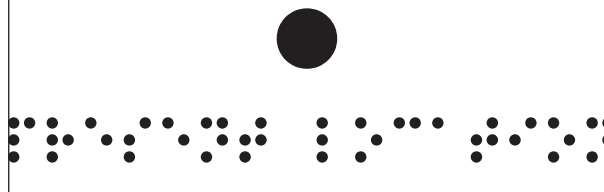

EXAMPLE 1 Present location.

Tactile mark (side view)	Implementation
	
Description	
<p>For a tactile figure, the margin of the height between the tactile figure and another mark should be different, obviously, such as a hemisphere that is about 1 mm to 5 mm high. In case of having space around a mark, in principle, “the present location” should be displayed in braille.</p>	

EXAMPLE 2 Tactile walking surface indicator.

Tactile mark	Implementation
	
Description	
<p>A tactile mark should be a round dotted line. The dimension and the interval of the circles can be transformed depending on the scale size and the complexity of the figure, but on the same tactile guide map, they should be standardized. In addition, actual number of indicators and dots need not be conformed.</p>	



EXAMPLE 3 Stairs.

Tactile mark	Implementation
	
Description	
<p>To convey directions of stairs, tactile marks should be displayed by isosceles triangles or equilateral triangles without the base. The direction should be arranged so that two sides intersect as “high” and the direction without sides as “low”. A space of more than about 6 mm between marks and lines that indicate the wall should be left. To facilitate proper use, an explanation should be included in the legend, e.g. ‘the sharp end denotes “up”.’</p>	

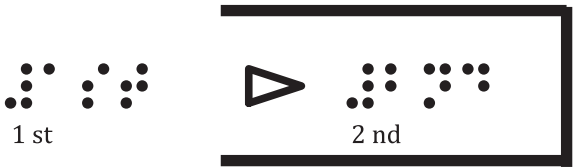
EXAMPLE 4 Escalators.

Tactile mark	Implementation
	
Description	
<p>To convey directions of stairs, tactile marks should be displayed by isosceles triangles or equilateral triangles. The direction should be arranged, so that two sides intersect as “high” and the direction without sides as “low”. A space of more than about 6 mm between marks and lines that indicate the wall should be left. To facilitate proper use, an explanation should be included in the legend, e.g. ‘the sharp end denotes “up”.’</p>	

EXAMPLE 5 Doorways.

Tactile mark	Implementation
 <p data-bbox="459 949 639 1003">Name of facility in braille</p>	 <p data-bbox="1091 1016 1150 1048">Shop</p>
Description	
<p>Display tactile marks of doorways of buildings by opening a part of lines surrounding the domain. In principle, doors and special marks should not be used to display tactile marks.</p>	

EXAMPLE 6 Non-accessible area.

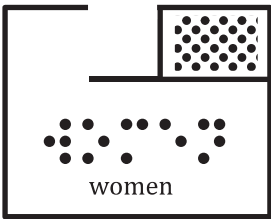
Tactile mark	Implementation
	 <p data-bbox="1070 1543 1155 1574">women</p>
Description	
<p>Non-accessible areas should be represented by surface patterns consisting of dots. The dimension and the interval of the circles can be transformed depending on the scale size and the complexity of the figure but surface marks should be standardized on the same tactile map.</p>	

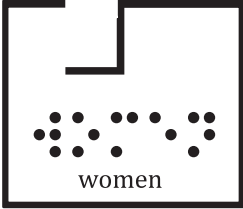

EXAMPLE 7 Toilet.

Tactile mark	Implementation
	
Description	
<p>Within the appropriate domain, display “Men” or “Women”. If all braille cannot be written within the domain, the abbreviations in braille can be written.</p>	

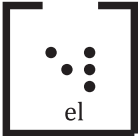
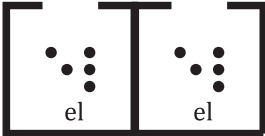
EXAMPLE 8 Lift (elevator).

Tactile mark	Implementation
	
Description	
<p>Tactile marks should be displayed within the appropriate domain in braille. If the tactile marks cannot be written in all braille within the domain, the abbreviations of braille should be written, such as “el”. Display doorways by opening a part of the visible outline of the equipment.</p>	

EXAMPLE 9 Reduced scale.

Tactile mark	Implementation
	
Description	
<p>Write in braille, which displays the measure and the distance matching on the upper side of both sides of a standard solid line.</p>	

EXAMPLE 10 Solid lined arrow for directions.

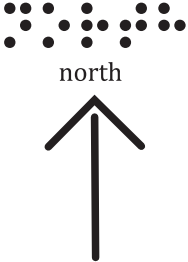
Tactile mark	Implementation
	
Description	
<p>Put “north” in braille up at the head of a solid lined arrow.</p>	

EXAMPLE 11 Solid lined arrow for destination.

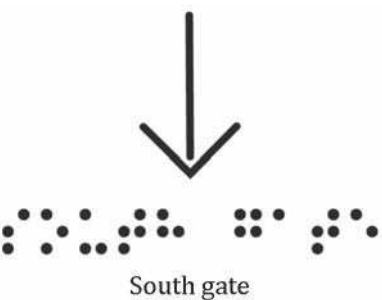
Tactile mark	Implementation
 <p data-bbox="405 510 675 539">Toward the destination</p>	 <p data-bbox="1054 600 1182 629">South gate</p>
Description	
<p data-bbox="268 692 1414 748">In case of displaying information of facilities outside of a tactile guide map, put braille down at the head of a solid lined arrow.</p>	

## Annex B (informative)

### German examples of tactile marks

All tactile guide marks outlined below are suggestions. Dimensions, shapes, details to the width of line, etc. are only of advisory nature. They need to be adapted to the overall conception of the guide map and the guiding requirements derived from the actual floor plan or access route, e.g. number and length of stairs, width and structure of lines in relation to other lines.

EXAMPLE 1 Present location/starting point.

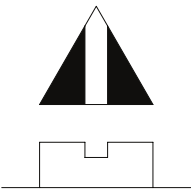
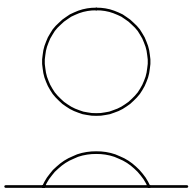
Tactile mark	Implementation	Description
	It should be the most prominent mark in the guide map: equilateral triangular column, preferably with notch going to one point of triangle to show walking direction.	Length of each side more than 10 mm, height of elevation more than 4 mm
	A round dot should alternatively be used.	Diameter from 8 mm to 10 mm, elevation more than 3 mm at minimum

EXAMPLE 2 Information desk.

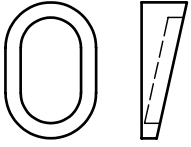

Tactile mark	Implementation	Description
	Information mark "I" with dot and serifs	Vertical height of "I" mark more than 10 mm, elevation more than 1,2 mm

EXAMPLE 3 Position of other tactile information points or maps with further guiding information.

Tactile mark	Implementation	Description
	Elongated dot shape showing the position of other tactile mark with further guiding information	Raised elongated big dot, width more than 6 mm, length more than 9 mm. The rim of the mark should be 1 mm wide, central part 1 mm lower than the rim. Preferably, the tactile mark should be titled like a desk installation with the upper side having an elevation of more than 3 mm and the lower side 1 mm. Alternatively, the mark can have a full, flat, rough surface.



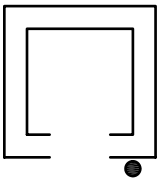

EXAMPLE 4 Elevator.

Tactile mark	Implementation	Description
	Two squares (one placed inside the other) with opening showing door(s). One side of door opening should have a dot/tiny projection to indicate the call button in very large scale maps. The range of floors where the elevator serves, could be added, e.g. -2 to +11.	Inner square raised to outer square by 0,8 mm, size of outer square more than (15 × 15) mm
	Crossed blank square	Cross more than (10 × 10) mm, with unstructured smooth lines of 2 mm width

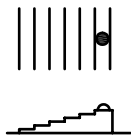
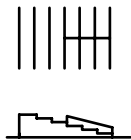
EXAMPLE 5 Stairs.

Tactile mark	Implementation	Description
	Stairs going upward from the actual floor level displayed in the map to an upper floor level or coming down from there.  In order to indicate the upside direction, the top part of stairs (escalators, moving walkways and ramps are the same) should be marked by a tiny dot.	Parallel lines for steps more than 1 mm in volume, width of tactile mark more than 7 mm, length more than 10 mm (may vary).  Dot in size of a braille dot (elevation from 0,6 mm to 0,8 mm, diameter from 1,2 mm to 1,6 mm)
	Stairs going downward from the actual floor in the map level to a lower floor level or coming up from there.  In order to indicate the direction, the bottom part of stairs (escalators, moving walkways, ramps are the same) should be marked by a short dash/line, combining the lowest three steps in the tactile mark.	



EXAMPLE 6 Escalator.

Tactile mark	Implementation	Description
	Dot indicates the upper side of escalator for direction of movement of escalator.	Two dominant broad lines for handrails and thinner/finer lines for steps. Handrails width more than 1,5 mm, distance of handrails more than 6 mm, distance of steps more than 0,6 mm
	Short dash indicates the lower side of escalator for direction of movement of escalator.	

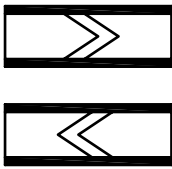
EXAMPLE 7 Moving walkways/travellator.

Tactile mark	Implementation	Description
	When moving walkways are going up or down to another floor level, they should be marked by a dot or dash, respectively.	Two broad lines. Direction of movement should be marked by two V-shaped arrows between the handrails.

EXAMPLE 8 Giving indication of the movement of escalators, moving walkways.

Tactile mark	Implementation	Description
	Escalator to higher floor moving upwards	Parallel lines for steps should be 1,5 mm in volume. Width of tactile mark 10 mm, length more than 15 mm (may vary)
	Escalator from higher floor moving downwards	V-shaped sign on top of mark. Width of lines more than 0,8 mm, preferably in contrasting colour to steps and handrails

EXAMPLE 9 Ramp.

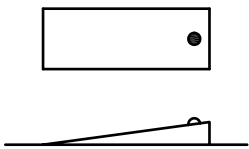
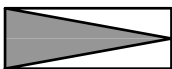
Tactile mark	Implementation	Description
	Profiled ramp with right-hand side raised	Elevated part of the ramp in the profiled type should be raised by more than 2 mm to lower end. Dot may be used to indicate upper side or short dash to indicate lower end in relation to the actual floor level of the map.
	A flat mark uses a rough triangle in a square or rectangle. The point or dash of middle triangle also indicates whether the ramp goes down or up from the actual floor level.	Central triangle (marked grey) raised by 0,8 mm and should have a rough structure.

EXAMPLE 10 Non-accessible area in floor plan.

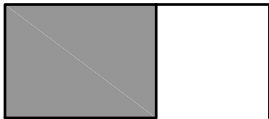
Tactile mark	Implementation	Description
	Blank raised area to the level of outer walls of the building	Elevation of raised area more than 1,5 mm (grey area in sketch)

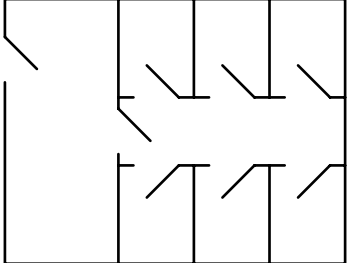

EXAMPLE 11 Restroom (toilet).

Tactile mark	Implementation	Description
 <p>The diagram shows a rectangular room layout with a door on the left wall. Inside, there are two rows of stalls. Each stall is represented by a vertical line with a diagonal line indicating the door. Tactile marks are shown as short, thick lines along the walls and around the door frame.</p>	<p>It may be reduced to small compartment with doors and name of establishment in braille or raised lettering.</p>	<p>To indicate the position of the cabins in relation to the door is of greater importance than to label the establishment with a full name. A letter or number may be sufficient, which needs to be explained in the legend.</p>

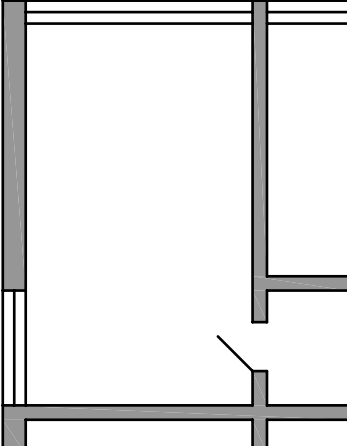
EXAMPLE 12 Room.

Tactile mark	Implementation	Description
 <p>The diagram shows a room with a door on the left wall and a window on the right wall. The tactile marks are represented by thick lines along the walls and around the door frame. The window is represented by thin lines.</p>	<p>Room with opening for door and door blade, fine lines for windows in outer wall (If scale is sufficiently large, windows could be presented by a thinner line than the line for outer walls.)</p>	<p>Outer wall width more than 2 mm, window width 0,8 mm</p>

EXAMPLE 13 Doors with various blade arrangements.

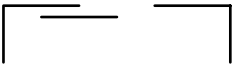
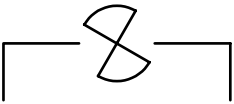
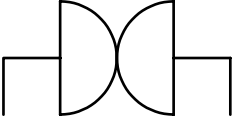
Tactile mark	Implementation	Description
	Door opening	Opening in wall
	Door opening with door blade. Door blade indicates the opening direction of a door	Door blade short line at an angle of 45°
	Door opening with double door blades	
	Sliding door(s)	Parallel line to wall indicates sliding door blade. Door blade of sliding door covers half of the door opening.
	Revolving door with four door blades	Two blades projecting at an angle of about 30° into the door opening
	Swing door(s)	Door with door blade(s) and arc showing the direction and range of the swing area of the door blade(s)

EXAMPLE 14 Main entrance to building.

Tactile mark	Implementation	Description
	Building mark with main entrance in an access route.  In a floor plan, the main entrance should be indicated by lettering the respective door(s).	In a building mark, the main entrance should be shown by a triangle projecting into the building. The remaining area of the building should have a (textured) rough surface.

EXAMPLE 15 Building with side walk at two sides.

Tactile mark	Implementation	Description
	When in a street, the profile of the street should be with refuge and/or median strip displayed sidewalk can be indicated.	Width of sidewalk more than 5 mm, elevation of sidewalk to road more than 0,5 mm. Elevation of building to sidewalk in mark should be 0,5 mm to 0,8 mm above the sidewalk.

EXAMPLE 16 Tram line with tram stops.

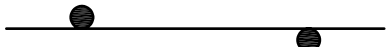
Tactile mark	Implementation	Description
	Smooth unstructured line with flat dots showing tram stops	Tram stops, flat dots with diameter of more than 4 mm

EXAMPLE 17 Bus line with bus tops.

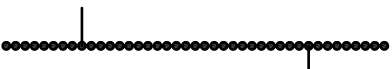
Tactile mark	Implementation	Description
	Dot line with short lateral strokes showing bus stops	Lateral strokes more than 3 mm

EXAMPLE 18 Tram and bus lines with stops.

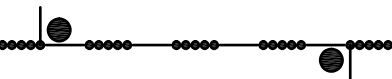
Tactile mark	Implementation	Description
	Tram and bus lines going in one street can be displayed by a combined line.	A combination of alternating smooth unstructured (tram) and dotted (bus) lines with respective stop marks

EXAMPLE 19 Entrance to underground (metro) line.

Tactile mark	Implementation	Description
	The stair side of the entrance should be marked either by stairs or it can be raised (dark area in sketch).	Two squares, one blank and one dark raised by more than 1,2 mm

EXAMPLE 20 Train/rail lines.

Tactile mark	Implementation	Description
	When railway lines are close to access route, they should be marked, since they usually can be used to conveniently identify one's position.	Width of line 2 mm, length more than 3,5 mm, gaps in line 1,5 mm

EXAMPLE 21 Taxi rank.

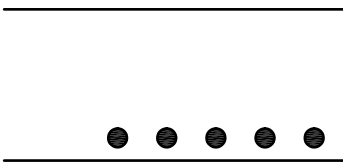
Tactile mark	Implementation	Description
	Very loose line of 4 dots to 5 dots along a road side/sidewalk	Diameter of dots 2,5 mm, distance between dots from 4 mm to 5 mm

EXAMPLE 22 Pedestrian crossing.

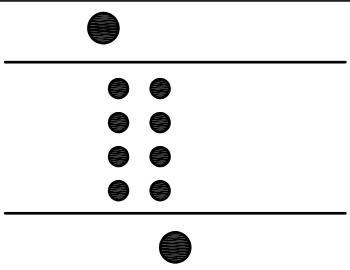
Tactile mark	Implementation	Description
	Two parallel lines of dots across the road. Depending on the scale of the map, traffic lights can be included by a bigger flat dot.	Dots from 2 mm to 2,5 mm, distance of dots to each other about 2 mm to 2,5 mm, distance of lines from 3 mm to 3,5 mm, flat dot from 3 mm to 4 mm in diameter for traffic lights, raised more than 2 mm. When acoustic traffic lights are available, they can be indicated by a tiny dot in the middle of the traffic lights dot, size from 0,5 mm to 1 mm.

EXAMPLE 23 TWSIs — attention field.

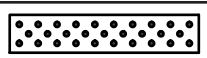
Tactile mark	Implementation	Description
	It is used for demarcation lines or areas, for warnings or to indicate decision points.	In extended scale presentation, area with dots. In narrow presentation (especially in combination with a top view of stairs), the attention field mark should have a slightly rough surface.

EXAMPLE 24 TWSIs — guiding path.

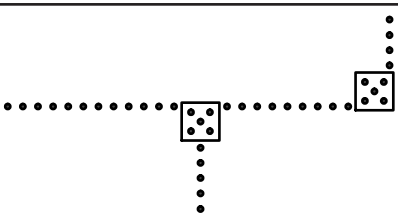
Tactile mark	Implementation	Description
	Very fine line of dots with rough small squares showing decision points (e.g. branching or turning points of guide path)	Diameter of dots from 0,5 mm to 1 mm (smaller than braille dots), decision point more than (2 × 2) mm

EXAMPLE 25 Guiding path without TWSI marking.

Tactile mark	Implementation	Description
	Fine interrupted line of dots as in guide path marked by TWSI, but interrupted by small gaps between groups of from 3 dots to 4 dots.	Diameter of dots from 0,5 mm to 1 mm (smaller than braille dots), width of gaps between groups 3 mm

EXAMPLE 26 Footpath.

Tactile mark	Implementation	Description
	Loose line of dots	Dots more than 2 mm, distance between dots more than 3 mm

EXAMPLE 27 Bridge.

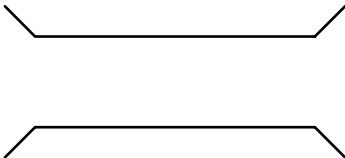
Tactile mark	Implementation	Description
	When the bridge can be passed only via steps or stairs, the steps should be marked by lines as in top view of stairs.	Width of bridge depends on width of street or footpath.

EXAMPLE 28 Water.

Tactile mark	Implementation	Description
	It is used for ponds, creeks, rivers, lakes.	Area with waved (corrugated) or very fine, narrow straight lines

EXAMPLE 29 Arrows showing destination or direction for travelling.

Tactile mark	Implementation	Description
	It is used preferably for indicating directional information going over the margin out of the map or coming from outside into the map.	For clarity, only open arrows should be used to give directional information.

EXAMPLE 30 Scale.

Tactile mark	Implementation	Description
	Distances preferably in metres depending on size of scale applied for map. (Capital "M" may be used only in raised lettering.)	

EXAMPLE 31 Arrow showing the north direction.

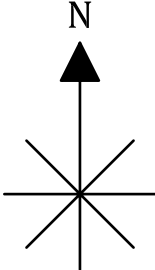
Tactile mark	Implementation	Description
	If possible, the pointer should go into the top right hand corner of the map, or alternatively, close to the scale information.	The pointer arrow showing the North should be a closed triangle. Size of mark more than 15 mm.

## Annex C (informative)

### Swedish examples of tactile marks

EXAMPLE 1 Guidance strip (representing tactilely marked and obstacle free walking paths).

Tactile mark	Implementation	Description
	Representing tactilely marked and obstacle free walking paths	Black, 5 mm wide, visual line with white tactile dots. Alternatively, black tactile dots on white visual line. Dots are 1 mm in diameter, 0,5 mm in height. Length in legend 22 mm

EXAMPLE 2 Wall/kerbstone (representing outer wall around building, and inner wall within building, as well as kerbstone around plantation, traffic island and pavement).

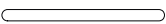
Tactile mark	Implementation	Description
	Representing wall or kerbstone of interest for tactile orientation	White tactile line with black visual contour, 1,5 mm in width. Length in legend 20 mm

EXAMPLE 3 Outside wall/handrail (representing wall, railings, or fence).

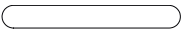
Tactile mark	Implementation	Description
	Representing wall, railings, or fence, of larger interest for tactile orientation than the wall/kerbstone tactile element	White textured tactile line with black visual contour, 3 mm in width. Length in legend 20 mm

EXAMPLE 4 Tram track.

Tactile mark	Implementation	Description
	Representing tram tracks	Two parallel tactile black lines without texture, 1 mm in width, 4 mm between centres of lines. Length in legend 22 mm



EXAMPLE 5 Railway track.

Tactile mark	Implementation	Description
	Representing railway tracks, to be used in combination with platforms and numbers	Two parallel tactile black lines without texture, 1 mm in width, 4 mm between centres of lines. Ribbons connecting lines with 8 mm between centres of ribbons. Length in legend 21 mm

EXAMPLE 6 Stairs (composed by three lines/steps in legend).

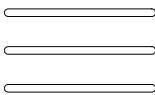
Tactile mark	Implementation	Description
	Representing stairs. Number of lines do not represent stairs or levels.	White tactile line without texture with black visual contour, 1 mm in width, length in legend 20 mm. Number of lines/steps on map varies. 5 mm between centres of lines

EXAMPLE 7 Pedestrian crossing (composed by three lines in legend).

Tactile mark	Implementation	Description
	Representing pedestrian crossings, not necessarily safe/supervised crossings	Black tactile line without texture with black visual contour, 3 mm in width. Length in legend 20 mm. Number of lines on map varies. 7 mm between centres of lines

EXAMPLE 8 Position of tactile guide map.

Tactile mark	Implementation	Description
	Representing the position of the tactile guide map. May preferably be made of a line (an open circle)	Red tactile dot, 8 mm in diameter. Should be given the highest tactile level on the map

EXAMPLE 9 Bollard/Post (representing obstacle/point of orientation as bollard, post, or pillar).

Tactile mark	Implementation	Description
	Representing bollard or post, to be used with care, only to represent objects of interest for guidance	White tactile full circle with black visual contour, 4 mm in diameter

**ISO 19028:2016(E)**

EXAMPLE 10 Bench (representing place to seat, bench, indoor or outdoor).

Tactile mark	Implementation	Description
	Representing bench or place to seat, when of interest	Black tactile rectangle without texture, (15 × 6) mm in width with rounded angles

EXAMPLE 11 Weather protection shelter (representing shelter at platform, at bus stop, at tram stop, or at taxi stand).

Tactile mark	Implementation	Description
	Representing weather protection shelter, when of interest	Black tactile symbol without texture. Line 2 mm in width. Total size (25 × 12) mm. Consists of one longer line, 25 mm, and three shorter lines, 12 mm in length, at each end and in the middle of the longer line

EXAMPLE 12 Shelter (representing shelter for reading, wind shelter, wall made of glass).

Tactile mark	Implementation	Description
	Representing shelter, when of interest	

EXAMPLE 13 Intersection of tracks.

Tactile mark	Implementation	Description
	Representing intersection of tracks in order to give awareness of need for attention for trains or trams	Black tactile cross, (13 × 13) mm in width. Line 2 mm in width with rounded edges

EXAMPLE 14 Intersection of tracks with gates.

Tactile mark	Implementation	Description
	Representing intersection of tracks with gates in order to give awareness of need for attention for gates or barriers in connection with passing trains or trams	Black tactile symbol without texture made by an 8 mm circle, a (8 × 4) mm rectangle with rounded edges, and a 10 mm line, 1 mm in width with rounded end. Combined length approximately (28 × 8) mm

EXAMPLE 15 Scale.

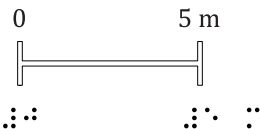
Tactile mark	Implementation	Description
	Scale example. With relevant scale, e.g. 1 m to 5 m	White tactile line with ending lines, with black visual contour, 1 mm in width. Visual text above and braille text under each end

EXAMPLE 16 Ramp, moving walkway.

Tactile mark	Implementation	Description
	Representing ramp and moving walkway	

## Bibliography

- [1] ISO 17840-1:2015, *Road vehicles — Information for first and second responders — Part 1: Rescue sheet for passenger cars and light commercial vehicles*
- [2] ISO 23599, *Assistive products for blind and vision-impaired persons — Tactile walking surface indicators*



