

---

---

**Rubber hoses and tubing for fuel  
circuits for internal combustion  
engines — Specification —**

**Part 2:  
Gasoline fuels**

*Tuyaux de caoutchouc et flexibles pour les circuits de carburant pour  
les moteurs à combustion interne — Spécifications —*

*Partie 2: Essences*





**COPYRIGHT PROTECTED DOCUMENT**

© ISO 2016, Published in Switzerland

All rights reserved. Unless otherwise specified, no part of this publication may be reproduced or utilized otherwise in any form or by any means, electronic or mechanical, including photocopying, or posting on the internet or an intranet, without prior written permission. Permission can be requested from either ISO at the address below or ISO's member body in the country of the requester.

ISO copyright office  
Ch. de Blandonnet 8 • CP 401  
CH-1214 Vernier, Geneva, Switzerland  
Tel. +41 22 749 01 11  
Fax +41 22 749 09 47  
copyright@iso.org  
www.iso.org

# Contents

	Page
<b>Foreword</b> .....	<b>iv</b>
<b>1 Scope</b> .....	<b>1</b>
<b>2 Normative references</b> .....	<b>1</b>
<b>3 Classification</b> .....	<b>2</b>
<b>4 Sizes</b> .....	<b>2</b>
4.1 Tubing .....	2
4.2 Hoses .....	3
<b>5 Performance requirements for hose and tubing</b> .....	<b>4</b>
<b>6 Frequency of testing</b> .....	<b>6</b>
<b>7 Marking</b> .....	<b>6</b>
<b>Annex A (normative) Cleanliness and extractables test</b> .....	<b>7</b>
<b>Annex B (normative) Resistance of tubing to tearing</b> .....	<b>9</b>
<b>Annex C (normative) Method for determining the resistance to surface contamination</b> .....	<b>12</b>
<b>Annex D (normative) Preparation of peroxidized test fuel</b> .....	<b>13</b>
<b>Annex E (normative) Copper corrosion and crystalline salt formation</b> .....	<b>17</b>
<b>Annex F (normative) Life-cycle test</b> .....	<b>18</b>
<b>Annex G (informative) Example of how a non-standard type of hose or tubing could be specified by an original equipment manufacturer (OEM) using a matrix</b> .....	<b>19</b>
<b>Annex H (normative) Type tests</b> .....	<b>20</b>
<b>Annex I (normative) Routine tests</b> .....	<b>21</b>
<b>Annex J (informative) Production acceptance tests</b> .....	<b>22</b>

## Foreword

ISO (the International Organization for Standardization) is a worldwide federation of national standards bodies (ISO member bodies). The work of preparing International Standards is normally carried out through ISO technical committees. Each member body interested in a subject for which a technical committee has been established has the right to be represented on that committee. International organizations, governmental and non-governmental, in liaison with ISO, also take part in the work. ISO collaborates closely with the International Electrotechnical Commission (IEC) on all matters of electrotechnical standardization.

The procedures used to develop this document and those intended for its further maintenance are described in the ISO/IEC Directives, Part 1. In particular the different approval criteria needed for the different types of ISO documents should be noted. This document was drafted in accordance with the editorial rules of the ISO/IEC Directives, Part 2 (see [www.iso.org/directives](http://www.iso.org/directives)).

Attention is drawn to the possibility that some of the elements of this document may be the subject of patent rights. ISO shall not be held responsible for identifying any or all such patent rights. Details of any patent rights identified during the development of the document will be in the Introduction and/or on the ISO list of patent declarations received (see [www.iso.org/patents](http://www.iso.org/patents)).

Any trade name used in this document is information given for the convenience of users and does not constitute an endorsement.

For an explanation on the meaning of ISO specific terms and expressions related to conformity assessment, as well as information about ISO's adherence to the WTO principles in the Technical Barriers to Trade (TBT) see the following URL: [Foreword - Supplementary information](#)

The committee responsible for this document is ISO/TC 45, *Rubber and rubber products*, Subcommittee SC 1, *Rubber and plastics hoses and hose assemblies*.

This second edition cancels and replaces the first edition (ISO 19013-2:2005), which has been technically revised.

ISO 19013 consists of the following parts, under the general title *Rubber hoses and tubing for fuel circuits for internal combustion engines — Specification*:

- *Part 1: Diesel fuels*
- *Part 2: Gasoline fuels*

# Rubber hoses and tubing for fuel circuits for internal combustion engines — Specification —

## Part 2: Gasoline fuels

**WARNING — Persons using this part of ISO 19013 should be familiar with normal laboratory practice. This part of ISO 19013 does not purport to address all of the safety problems, if any, associated with its use. It is the responsibility of the user to establish appropriate safety and health practices and to ensure compliance with any national regulatory conditions.**

### 1 Scope

This part of ISO 19013 specifies the requirements for rubber tubing and hoses used in gasoline fuel circuits for internal combustion engines. The gasoline fuels covered include those containing oxygenates such as methanol and fuels that have become oxidized (“sour gas”). In addition, this part of ISO 19013 can also be applied as a classification system to enable original equipment manufacturers (OEMs) to detail a “line call-out” of tests for specific applications where these are not covered by the main types specified (see example in Annex G). In this case, the hose or tubing would not carry any marking showing the number of this part of ISO 19013, but may detail the OEM’s own identification markings as shown on their part drawings.

### 2 Normative references

The following documents, in whole or in part, are normatively referenced in this document and are indispensable for its application. For dated references, only the edition cited applies. For undated references, the latest edition of the referenced document (including any amendments) applies.

ISO 188, *Rubber, vulcanized or thermoplastic — Accelerated ageing and heat resistance tests*

ISO 1402, *Rubber and plastics hoses and hose assemblies — Hydrostatic testing*

ISO 1629, *Rubber and latices — Nomenclature*

ISO 1817, *Rubber, vulcanized or thermoplastic — Determination of the effect of liquids*

ISO 3302-1, *Rubber — Tolerances for products — Part 1: Dimensional tolerances*

ISO 4671, *Rubber and plastics hoses and hose assemblies — Methods of measurement of the dimensions of hoses and the lengths of hose assemblies*

ISO 4926, *Road vehicles — Hydraulic braking systems — Non-petroleum-base reference fluids*

ISO 6133, *Rubber and plastics — Analysis of multi-peak traces obtained in determinations of tear strength and adhesion strength*

ISO 7233:2006, *Rubber and plastics hoses and hose assemblies — Determination of resistance to vacuum*

ISO 7326:2006, *Rubber and plastics hoses — Assessment of ozone resistance under static conditions*

ISO 8031:2009, *Rubber and plastics hoses and hose assemblies — Determination of electrical resistance and conductivity*

ISO 8033, *Rubber and plastics hoses — Determination of adhesion between components*

## ISO 19013-2:2016(E)

ISO 10619-1, *Rubber and plastics hoses and tubing — Measurement of flexibility and stiffness — Part 1: Bending tests at ambient temperature*

ISO 10619-2:2011, *Rubber and plastics hoses and tubing — Measurement of flexibility and stiffness — Part 2: Bending tests at sub-ambient temperatures*

ISO 23529, *Rubber — General procedures for preparing and conditioning test pieces for physical test methods*

ASTM D130, *Standard Test Method for Corrosiveness to Copper from Petroleum Products by Copper Strip Test*

SAE J1737, *Test Procedure to Determine the Hydrocarbon Losses from Fuel Tubes, Hoses, Fittings, and Fuel Line Assemblies by Recirculation*

SAE J2027:1998, *Standard for Protective Covers for Gasoline Fuel Line Tubing*

SAE J2044:2002, *Quick Connect Coupling Specification for Liquid Fuel and Vapor/Emissions Systems*

SAE J2260, *Nonmetallic Fuel System Tubing with One or More Layers*

### 3 Classification

The product shall consist of extruded rubber materials with or without an integral internal or external reinforcement which may or may not be pre-formed before final vulcanization. The product may also have a rubber or thermoplastic barrier layer, either as an internal layer or forming the inner liner, to impart improved fuel resistance and/or reduced fuel vapour permeability.

Seven hoses and tubings for specific applications are specified as follows.

- Type 1 Class A = Pressurized [0,7 MPa (7 bar) working pressure] feed and return lines from the fuel tank to the engine compartment (−40 °C to +80 °C continuous).
- Class B = Pressurized [0,2 MPa (2 bar) working pressure] feed and return lines from the fuel tank to the engine compartment (−40 °C to +80 °C continuous).
- Type 2 Class A = Pressurized [0,7 MPa (7 bar) working pressure] feed and return lines in the engine compartment (−40 °C to +100 °C continuous).
- Class B = Pressurized [0,2 MPa (2 bar) working pressure] feed and return lines in the engine compartment (−40 °C to +100 °C continuous).
- Type 3 Class A = Pressurized [0,7 MPa (7 bar) working pressure] feed and return lines in the engine compartment (−40 °C to +125 °C continuous).
- Class B = Pressurized [0,2 MPa (2 bar) working pressure] feed and return lines in the engine compartment (−40 °C to +125 °C continuous).
- Type 4 Low pressure [0,12 Mpa (1,2 bar) working pressure] fuel filler, vent, and vapour handling (−40 °C to +80 °C continuous).

All types and classes can also be designated reduced fuel vapour permeable (RP), e.g. Type 1 Class A RP.

### 4 Sizes

#### 4.1 Tubing

When determined by the methods described in ISO 4671, inside diameters and wall thicknesses shall be as specified in [Table 1](#).

Tolerances shall be selected from the appropriate categories specified in ISO 3302-1; M3 for moulded hoses and E2 for extrusions.

The thickness of the barrier layer, where applicable, shall be included in the total nominal wall thickness shown in [Table 1](#).

**Table 1 — Tubing inside diameters and wall thicknesses**

Inside diameter mm	Wall thickness mm
3,5	3,5
4	3,5
5	4
7	4,5
9	4,5
11	4,5
13	4,5

NOTE For information, the unions on which the tubing is to be fitted have the following diameters: 4 mm, 4,5 mm, 6 mm or 6,35 mm, 8 mm, 10 mm, 12 mm, and 14 mm.

## 4.2 Hoses

When determined by the methods described in ISO 4671, the dimensions and concentricity of hoses shall comply with [Tables 2](#) and [3](#).

The thickness of the barrier layer, where applicable, shall be included in the total nominal wall thickness shown in [Table 2](#).

**Table 2 — Hose dimensions**

Dimensions in millimetres

Inside diameter	Tolerance	Wall thickness	Outside diameter	Tolerance
3,5	±0,3	3	9,5	±0,4
4	±0,3	3	10	±0,4
5	±0,3	3	11	±0,4
6	±0,3	3	12	±0,4
7	±0,3	3	13	±0,4
7,5	±0,3	3	13,5	±0,4
8	±0,3	3	14	±0,4
9	±0,3	3	15	±0,4
11	±0,3	3,5	18	±0,4
12	±0,3	3,5	19	±0,4
13	±0,4	3,5	20	±0,6
16	±0,4	4	24	±0,6
21	±0,4	4	29	±0,6
31,5	+0,5 -1	4,25	40	±1
40	+0,5 -1	5	50	±1

Table 3 — Hose concentricity

Inside diameter mm	Maximum variation from concentricity mm
Up to and including 3,5	0,4
Over 3,5	0,8

## 5 Performance requirements for hose and tubing

Tests shall be selected from the following list for each application of hose or tubing based on the performance requirements for the finished product. Type tests (as defined in [Clause 6](#)) for each hose or tubing group are given in Annex H.

- a) **Burst pressure:** When determined in accordance with ISO 1402, the minimum burst pressure for Types 1, 2, and 3, Class A shall be 3,0 MPa gauge (30 bar) and shall be 1,2 MPa gauge (12 bar) for Class B. Type 4 shall be 0,5 MPa gauge (5 bar). Additionally, after fuel resistance testing [test m)], hoses and tubing shall not have a burst pressure of less than 75 % of the original burst pressure.
- b) **Proof pressure:** When determined in accordance with ISO 1402, the test pressure for Types 1, 2, and 3, Class A shall be 1,5 MPa gauge (15 bar) and shall be 0,6 MPa gauge (6 bar) for Class B. Type 4 shall be 0,25 MPa gauge (2,5 bar). The hose shall not burst or not fail by showing sign of leakage.
- c) **Adhesion** (for all constructions with two or more bonded layers only): When determined by the appropriate procedure in ISO 8033, the adhesion between each pair of bonded layers shall not be less than 1,5 kN/m.
- d) **Low-temperature flexibility:** When tested in accordance with ISO 10619-2:2011, method B, a length of hose or tubing which has been previously kept filled with ISO 1817 liquid C for 72 h  $\pm$  2 h at 21 °C  $\pm$  2 °C and then kept cooled at -40 °C  $\pm$  2 °C for 72 h  $\pm$  2 h shall not exhibit any cracking when examined under  $\times 2$  magnification after bending around a similarly cooled mandrel, the radius of which is 12 times the nominal size of the hose or 25 times the nominal size of the tubing. The hose or tubing shall then conform to the burst strength requirement of test a).
- e) **Internal cleanliness:** When determined in accordance with Annex A, the insoluble impurities shall not exceed 5 g/m<sup>2</sup> and the fuel-soluble impurities shall not exceed 3 g/m<sup>2</sup>.
- f) **Extractable waxy materials:** When determined in accordance with Annex A, the extractable waxy materials shall not exceed 2,5 g/m<sup>2</sup>.
- g) **Tear resistance** (applicable to tubing only): When determined in accordance to Annex B, the minimum tear resistance shall be 4,5 kN/m.
- h) **Ozone resistance:** When tested in accordance with ISO 7326:2006, method 1 under the following conditions, the hose or tubing shall not show cracking when examined under  $\times 2$  magnification:

Partial pressure of ozone	50 mPa $\pm$ 3 mPa
Duration	72 h $\pm$ 2 h
Temperature	40 °C $\pm$ 2 °C
Elongation	20 %
- i) **Heat ageing resistance:** After ageing for one or more of the following times and temperatures in accordance with ISO 188, all constructions shall meet the adhesion requirements of test b), the low-temperature flexibility requirements of test c), and the ozone resistance requirements of test g).
  - 1) 1 000 h at 80 °C.



- 2) 1 000 h at 100 °C.
- 3) 1 000 h at 125 °C.
- 4) 168 h at 100 °C.
- 5) 168 h at 125 °C.
- 6) 168 h at 140 °C.

NOTE The 1 000 h tests represent long-term working temperatures and the 168 h tests represent short-term peak working temperatures.

- j) **Resistance to surface contamination by engine oil:** When tested in accordance with Annex C using ISO 1817 oil 3, all constructions shall meet the adhesion requirements of test b), the cold flexibility requirements of test c) and the ozone resistance requirements of test g).
- k) **Resistance to surface contamination by non-petroleum hydraulic (brake/clutch) fluid:** When tested in accordance with Annex C using hydraulic fluid to ISO 4926, all constructions shall meet the adhesion requirements of test b), the cold flexibility requirements of test c), and the ozone resistance requirements of test g).
- l) **Resistance to kinking** (this requirement applies only to straight hoses and tubing with a nominal size of 16 mm or less): When determined in accordance with ISO 10619-1, the maximum coefficient of deformation ( $T/D$ ) shall not exceed 0,7. The mandrel diameter shall be 140 mm for hoses and tubing up to nominal size 11 mm and 220 mm for hoses and tubing of nominal size from 12 mm to 16 mm.
- m) **Resistance to vacuum** (this requirement applies only to straight hoses and tubing): When the hose or tubing is tested in accordance with ISO 7233:2006, method A at 0,08 MPa absolute (0,8 bar) for 15 s to 60 s duration with a ball of diameter  $0,8 \times$  the nominal size, the ball shall traverse the full length of the hose or tubing.
- n) **Resistance to fuels:** When tested by the methanol fuel resistance test of SAE J2260 for a test duration of 5 000 h using one or more of the following test fuels at a fuel temperature of  $60 \text{ °C} \pm 2 \text{ °C}$ , all constructions shall meet the adhesion requirements of test b), the cold flexibility requirements of test c), the ozone resistance requirements of test g), the kinking resistance of test k), and the suction resistance of test l).
  - 1) A mixture of 85 % by volume of liquid C (ISO 1817) and 15 % by volume of methanol.
  - 2) A mixture of 75 % by volume of liquid C (ISO 1817) and 25 % by volume of methanol.
  - 3) A mixture of 50 % by volume of liquid C (ISO 1817) and 50 % by volume of methanol.
  - 4) A mixture of 85 % by volume of methanol and 15 % by volume of liquid C (ISO 1817).
  - 5) 100 % by volume of methanol.
  - 6) A mixture prepared in accordance with Annex D and peroxidized to a peroxide number of 90. Recheck the peroxide number of the test fuel using the method given in [D.5](#) after each 70 h of testing. If the peroxide number falls below 80, replace the test fuel with fresh test fuel.
- o) **Burn-through resistance:** When tested in accordance with SAE J2027, the hose or tubing shall withstand a minimum of 60 s exposure to flame without loss of pressure.
- p) **Fuel permeability by recirculation** (RP hoses and tubing only): When determined in accordance with SAE J1737, the permeability to a mixture of 75 % by volume of liquid C (ISO 1817) and 25 % by volume of methanol at 60 °C and 13,8 kPa shall not exceed  $60 \text{ g/m}^2/24 \text{ h}$ .
- q) **Electrical resistance:** When determined in accordance with ISO 8031:2009, 4.5 to 4.7, the electrical resistance shall not exceed 10 M $\Omega$ .

- r) **Copper corrosion and crystalline salt formation:** When tested in accordance with Annex E, there shall be no tarnish on the copper strip greater than ASTM D130 classification 1. Nor shall there be any formation of crystalline material on the copper strip, on the inner liner material, or on the bottom of the test tube.
- s) **Life-cycle test** (types 1, 2, and 3 only): When tested in accordance with Annex F, hose and tubing shall meet the adhesion requirements of test b), the cold flexibility requirements of test c), and the ozone resistance requirements of test g).

## 6 Frequency of testing

Type tests and routine tests shall be as specified in Annexes I and J, respectively.

Type tests are those required to confirm that a particular hose or hose assembly design manufactured by a particular method from particular materials meets all the requirements of this part of ISO 19013. The tests shall be repeated at a maximum of five-year intervals or whenever a change in the method of manufacture or materials used occurs. They shall be performed on all sizes and types except those of the same size and construction.

Routine tests are those required to be carried out on each length of finished hose or hose assembly prior to dispatch.

Production tests are those specified in Annex J which should preferably be carried out to control the quality of manufacture. The frequencies in the Annex are given as a guide only.

## 7 Marking

All constructions shall be continuously marked with the following:

- a) the manufacturer's name or trade mark;
- b) the number and year of publication of this part of ISO 19013;
- c) the classification in accordance with [Clause 3](#);
- d) the inside diameter, in millimetres;
- e) the fuel, i.e. gasoline;
- f) the year and quarter of manufacture;
- g) the recycling code for the construction material in accordance with ISO 1629.

EXAMPLE      XXX/ISO 19013-2:2015/Type 2 Class A RP/11/Gasoline/1Q15/NBR/FKM.

## Annex A (normative)

### Cleanliness and extractables test

#### A.1 General

This annex specifies a method for the determination of the quantity of insoluble impurities (“dirt”), liquid C solubles, and waxy extractables present in hoses and tubing used in liquid-fuel circuits.

#### A.2 Principle

A quantity of ISO 1817 liquid C is left for a period of 24 h at ambient temperature inside a length of hose or tubing. After this time, the test piece is emptied and the inside washed by gravity flow of liquid C.

The total solution is collected and the insoluble matter filtered out, dried, and weighed. The remaining solution is evaporated to dryness and the total content of liquid C soluble material calculated. The waxy material is dissolved from this residue with methanol and the resulting solution is evaporated to dryness and weighed.

#### A.3 Apparatus and materials

**A.3.1 Glass filter funnel.**

**A.3.2 Evaporating dishes** (two).

**A.3.3 Beaker**, 250 cm.

**A.3.4 Fuel evaporator**, fitted with an extraction hood.

**A.3.5 Ventilated drying oven**, capable of being maintained at  $85\text{ °C} \pm 5\text{ °C}$ .

**A.3.6 Balance**, accurate to 0,1 mg.

**A.3.7 Sintered-glass filter**, porosity grade P3.

**A.3.8 Liquid C**, as specified in ISO 1817.

**A.3.9 Methanol**, minimum purity 99 %.

**A.3.10 Metal stoppers**, to seal the ends of the hoses/tubing.

#### A.4 Procedure

Take a length of hose or tubing between 300 mm and 500 mm in length and measure its internal dimensions. Plug one end with a metal stopper (A.3.10) and hang vertically. Fill this test piece fully with liquid C (A.3.8) and seal the top end with another metal stopper. Calculate the internal surface area in contact with liquid C taking into account the area in contact with the stoppers. Leave the test pieces for  $24\text{ h} \pm 30\text{ min}$  at  $21\text{ °C} \pm 2\text{ °C}$ .

## ISO 19013-2:2016(E)

At the end of this period, remove one of the stoppers and pour the contents into the beaker (A.3.3). Remove the other stopper and hang the hose or tubing vertically over the beaker. By means of the filter funnel (A.3.1), rinse the inside of the hose or tubing with five portions each of 20 cm<sup>3</sup> of liquid C.

Filter the entire contents of the beaker through the previously weighed sintered-glass filter (A.3.7), using a small amount of clean liquid C to rinse out the beaker. Collect the filtrate in a previously weighed evaporating dish (A.3.2). Dry the filter in the oven (A.3.5) at 85 °C ± 5 °C until a constant mass is obtained.

Calculate the total mass of insoluble matter.

Place the evaporating dish and its contents on the fuel evaporator (A.3.4) under the extraction hood and evaporate the liquid to dryness. Dry the residue in the oven at 85 °C ± 5 °C until a constant mass is obtained.

Calculate the total mass of soluble material extracted by liquid C.

Keep the dried residue in the evaporating dish under the extraction hood at 21 °C ± 5 °C for a minimum of 16 h then dissolve the residue in 30 cm<sup>3</sup> of methanol (A.3.9) at the same temperature. Filter the solution through the sintered-glass filter into the second pre-weighed evaporating dish. Rinse the first dish with 10 cm<sup>3</sup> of fresh methanol and filter as before. Rinse and filter once more.

Place the second evaporating dish containing the filtered solution on the fuel evaporator under the extraction hood and evaporate all the methanol. Dry the residue in the oven at 85 °C ± 5 °C until constant mass is attained.

Calculate, in g/m<sup>2</sup>, the mass of waxy extractables dissolved by the methanol per unit internal surface area.

## Annex B (normative)

### Resistance of tubing to tearing

#### B.1 General

This annex specifies the conditions governing tear resistance tests using a test piece taken from tubing in which the ratio of the inside to the outside diameter is 0,5 or less.

#### B.2 Principle

With the aid of a tensometer, measurements are taken to indicate the force required to propagate a tear initiated in the test piece.

#### B.3 Apparatus

**B.3.1 Knife**, carefully ground or **razor blade**.

**B.3.2 Tensometer**, with the following features:

- a) a device for recording load and cross-head movement;
- b) a constant cross-head movement of 100 mm/min  $\pm$  10 mm/min;
- c) grips capable of securing the test piece without damage or slippage.

**B.3.3 Wall-thickness gauge**, such as a comparator or thread counter.

#### B.4 Test pieces

##### B.4.1 Shape and dimensions

Each test piece shall be of the shape and dimensions shown in [Figure B.1](#).

##### B.4.2 Preparation

Using a knife or razor blade ([B.3.1](#)), cut a length of 80 mm  $\pm$  1 mm from the tubing. Starting at one end, slice the piece in half longitudinally over a distance of 30 mm  $\pm$  1 mm (slice section A). Continue the slit on one side only following slice section B in [Figure B.1](#).

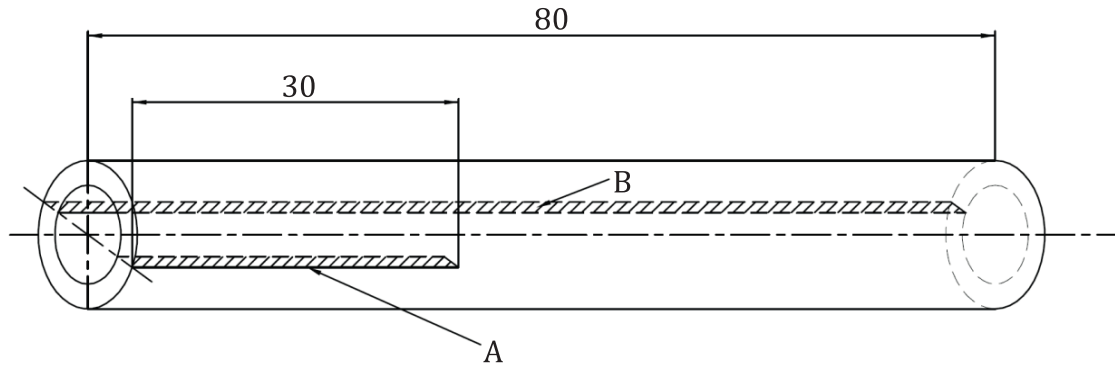

**Key**  
A, B slice section

**Figure B.1 — Shape and dimensions of the test piece**

**B.4.3 Number**

A minimum of three test pieces shall be tested.

**B.4.4 Conditioning**

Condition each test piece in accordance with ISO 23529.

**B.5 Procedure**

Using the wall-thickness gauge ([B.3.3](#)), measure the wall thickness of each test piece.

Mount a test piece in the grips (see [Figure B.2](#)).

Adjust the load scale and apply a tensile force until the test piece tears along its length.

Repeat for the remaining test pieces.

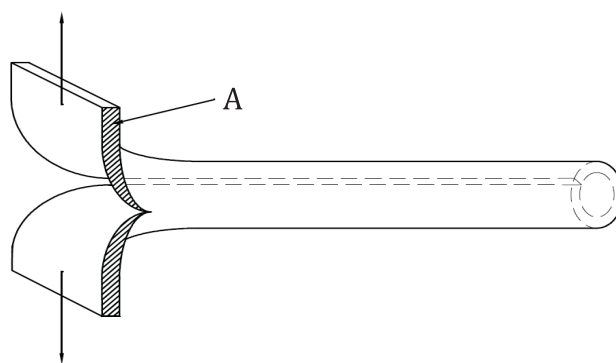

**Figure B.2 — Shape and the tensile direction of the test piece**

**B.6 Expression of results**

The load/time graphs will normally resemble that shown in [Figure B.3](#).

From each graph, determine, in accordance with ISO 6133, the median peak force required to tear the test piece.

Calculate the tear strength, in kilonewtons per metre, of each test piece by dividing the median peak force, in newtons, for that test piece by the wall thickness, in metres, of the test piece.

Calculate the mean tear strength for all the test pieces tested.

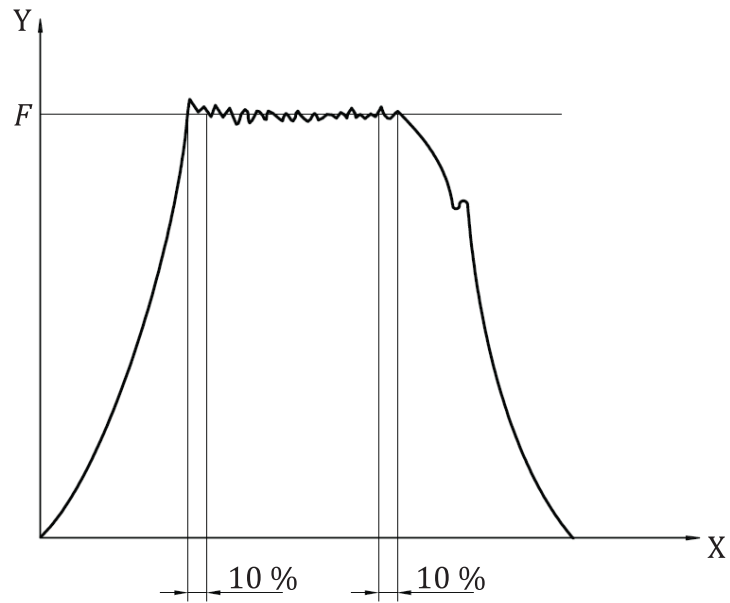

**Key**

X time

Y load

**Figure B.3 — Typical recording obtained during the tear resistance test on tubing**

## **Annex C** (normative)

### **Method for determining the resistance to surface contamination**

Tightly plug the ends of suitable lengths of hose or tubing to enable the adhesion test [[Clause 5](#), test b)], cold flexibility test [[Clause 5](#), test c)], and ozone resistance test [[Clause 5](#), test g)] to be carried out.

Fully immerse each test piece in the specified contaminating fluid for 2 h at 60 °C.

At the end of the immersion period, wipe the fluid from the surface of the hose or tubing and test as required.



## Annex D (normative)

### Preparation of peroxidized test fuel

#### D.1 General

This annex specifies a method of preparing peroxidized (“sour”) gasoline test solutions for use in the determination of their effects on elastomeric, plastic, and metallic materials and components. The Annex covers the preparation of a solution with a peroxide number of 90 using a mixture of *t*-butyl hydroperoxide (70 % aqueous solution), soluble cupric ion (0,01 mg/dm<sup>3</sup>), and a base fuel consisting of 80 % ISO 1817 liquid C, 15 % methanol, and 5 % 2-methyl-propan-2-ol (*t*-butyl alcohol) by volume. Other base fuels and peroxide numbers may be used as required by the engineering drawing or specification, but it should be noted that some base fuels may give rise to separation of the aqueous phase containing the hydroperoxide solution.

This annex also describes the determination of the peroxide number of the test fuel.

#### D.2 Reagents

**D.2.1 *t*-butyl hydroperoxide**, 70 % aqueous solution, density = 0,935 g/cm<sup>3</sup>.

**D.2.2 Cupric ion concentrate**, solution of cupric naphthenate containing 6 % to 12 % by mass of copper in an appropriate hydrocarbon solvent.

**D.2.3 2,3,4-trimethylpentane (iso-octane)**.

**CAUTION — Low flash point.**

**D.2.4 Toluene**.

**CAUTION — Low flash point.**

**D.2.5 Methanol**.

**CAUTION — Low flash point.**

**D.2.6 2-methylpropan-2-ol (*t*-butyl alcohol)**.

**CAUTION — Low flash point.**

#### D.3 Apparatus

**D.3.1 Polyethylene bottle**, capacity 1 000 cm<sup>3</sup> wide mouth with screw cap.

**D.3.2 Glass volumetric flasks**, capacity 1 000 cm<sup>3</sup>.

**D.3.3 Graduated glass pipettes**, capacity 10 cm<sup>3</sup>.

**D.3.4 Graduated glass measuring cylinders**, capacity 100 cm<sup>3</sup> and 1 000 cm<sup>3</sup>.

## D.4 Procedure

**CAUTION** — This procedure shall be carried out under a fume hood. Eye protection and disposable plastic gloves shall be worn.

### D.4.1 Preparation of test liquids

#### D.4.1.1 Base fuel mixture

Prepare ISO 1817 liquid C by mixing equal volumes of 2,2,4-trimethylpentane (D.2.3) and toluene (D.2.4). Store in a dark-glass bottle.

Mix ISO 1817 liquid C, methanol (D.2.5), and 2-methylpropan-2-ol (D.2.6) in the ratio 80:15:5 by volume to make the base fuel. Store in a dark-glass bottle.

#### D.4.1.2 Cupric ion stock solution (1 mg/dm<sup>3</sup>)

Add the appropriate volume of cupric ion concentrate (D.2.2) to the base fuel to produce 1 000 cm<sup>3</sup> of a 1,140 mg/cm<sup>3</sup> cupric ion solution (Cu-1). Store in a dark-glass bottle.

Add 100 cm<sup>3</sup> of Cu-1 to 1040 cm<sup>3</sup> of base fuel to produce a 0,1 mg/cm<sup>3</sup> cupric ion solution (Cu-2). Store in a dark-glass bottle.

Add 10 cm<sup>3</sup> of Cu-2 to 990 cm<sup>3</sup> of base fuel to produce a 1,0 mg/dm<sup>3</sup> cupric ion stock solution (CSS). Store in a dark-glass bottle.

#### D.4.1.3 Preparation of peroxidized test fuel

Use the mixture specified in Table D.1 to produce the test fuel with a peroxide number of 90. Store in a polyethylene bottle in the dark for no longer than four weeks. Check the peroxide number immediately after mixing and before subsequent use using the titrimetric test method described in D.5.

Add the *t*-butyl hydroperoxide solution (D.2.1) and cupric ion stock solution (CSS) (see D.4.1.2) to 500 cm<sup>3</sup> of base fuel in a 1 000 cm<sup>3</sup> volumetric flask (D.3.2), then make up to 1 000 cm<sup>3</sup> with base fuel shaking well to dissolve the water from the hydroperoxide solution in the alcohol phase of the base fuel.

**Table D.1 — Preparation of peroxidized test fuel**

Peroxide number	70 % <i>t</i> -butyl hydroperoxide solution	Cupric ion stock solution (CSS)	Base fuel
90	12,39 cm <sup>3</sup>	10 cm <sup>3</sup>	to 1 000 cm <sup>3</sup>

## D.5 Titrimetric determination of the peroxide number of peroxidized test fuel

### D.5.1 General

This subclause specifies a titrimetric method for determining the peroxide number of oxidized (“sour”) test fuels prepared using the procedure contained in D.4.

The method can be used to determine the peroxide number of peroxidized test fuel during the course of an immersion or circulation test. However, the following precautions shall be observed:

- a) most tests involving elastomers will result in the test liquid becoming yellowed by the extraction of additives in the rubber. This shall be taken into account when determining the end point of the titration;

- b) the additives extracted from the material under test may be capable of liberating free iodine from the iodide solution. A duplicate immersion or circulation test shall therefore be carried out as a blank using base fuel containing no hydroperoxide.

## D.5.2 Reagents

Unless otherwise stated, use only reagents of recognized analytical grade and only distilled water or water of equivalent purity.

**D.5.2.1 Potassium iodide**, 100 g/dm<sup>3</sup> solution. Store in a dark-glass reagent bottle. Discard if the solution gives a peroxide number of two or greater when carrying out a blank titration.

**D.5.2.2 Sodium thiosulfate**, standard volumetric solution,  $c(\text{Na}_2\text{S}_2\text{O}_3) = 0,1 \text{ mol/dm}^3$ .

**D.5.2.3 Ethanoic acid/propan-2-ol mixture.**

Mix 100 cm<sup>3</sup> of glacial ethanoic (acetic) acid with 150 ml of propan-2-ol. Store in a glass bottle.

## D.5.3 Apparatus

**D.5.3.1 Conical (Erlenmeyer) flask**, capacity 250 cm<sup>3</sup> with ground-glass neck.

**D.5.3.2 Condenser**, Allihn or Liebig water-cooled type with ground-glass joint to fit the conical flask ([D.5.3.1](#)).

**D.5.3.3 Graduated glass measuring cylinder**, capacity 100 cm<sup>3</sup>.

**D.5.3.4 Hotplate**, or other means of heating suitable for heating the conical flask with the condenser fitted to reflux the reagents.

**D.5.3.5 Glass burette**, capacity 10 cm<sup>3</sup>.

## D.5.4 Procedure

**D.5.4.1** Add 25 cm<sup>3</sup> of ethanoic acid/propan-2-ol mixture ([D.5.2.3](#)) to a 250 cm<sup>3</sup> conical flask ([D.5.3.1](#)).

**D.5.4.2** Add 10 cm<sup>3</sup> of potassium iodide solution ([D.5.2.1](#)) to the flask.

**D.5.4.3** Accurately transfer by pipette ([D.3.3](#)) 2 cm<sup>3</sup> of the peroxidized test fuel prepared in [D.4.1.3](#) to the flask.

**D.5.4.4** Fit the condenser ([D.5.3.2](#)) to the flask and reflux gently on the hotplate ([D.5.3.4](#)) for 5 min to release free iodine.

**D.5.4.5** Cool the flask in a cold-water bath and wash the condenser down with 5 cm<sup>3</sup> of water.

**D.5.4.6** Remove the condenser and titrate the contents of the flask with sodium thiosulfate solution ([D.5.2.2](#)) until the yellow coloration just disappears. Record the volume of sodium thiosulfate solution consumed as  $V_1$ .

**D.5.4.7** Carry out a blank determination by repeating steps [D.5.4.1](#) to [D.5.4.6](#), but omitting the addition of the peroxidized test fuel ([D.5.4.3](#)). Record the volume of sodium thiosulfate solution consumed as  $V_2$ . This volume shall not exceed 0,1 cm<sup>3</sup>.

### D.5.5 Expression of results

Calculate the peroxide number of peroxidized test fuel using Formula (D.1):

$$\text{Peroxide number} = \frac{(V_1 - V_2) \times c \times 1000}{2V_0} \quad (\text{D.1})$$

where

$V_0$  is the volume, in cubic centimetres, of peroxidized test fuel taken for the determination;

$V_1$  is the volume, in cubic centimetres, of sodium thiosulfate used for the actual titration;

$V_2$  is the volume, in cubic centimetres, of sodium thiosulfate used in the blank titration;

$c$  is the concentration of sodium thiosulfate used, in moles per cubic decimetre.

## Annex E (normative)

### Copper corrosion and crystalline salt formation

#### E.1 General

This annex describes a procedure for assessing the potential for fuel-extractable compounds in the inner liner material to cause corrosion or surface tarnishing of clean, pure copper surfaces found primarily in the electrical contacts and components of the fuel system. The procedure also detects the formation of crystalline copper compounds by interaction with fuel-extractable compounds in the liner material which can cause mechanical malfunction or blockages in the fuel system. The procedure is based on ASTM D130.

#### E.2 Apparatus and materials

**E.2.1 Test tubes**, 250 ml capacity with ground-glass neck to take a water condenser.

**E.2.2 Water condenser**, with a ground-glass socket to fit the 250 ml test tube.

**E.2.3 Inner liner material cut from hose or tube**, 12,5 mm wide by 75 mm long by liner thickness.

**E.2.4 Copper strips**, as specified in ASTM D130.

**E.2.5 Specimen holder**, made from stainless-steel wire suitably formed to hold the inner liner material and the copper strip 10 mm apart and parallel to each other.

**E.2.6 Polishing materials**, as specified in ASTM D130.

**E.2.7 Water bath**, thermostatically controlled to maintain a temperature of  $60\text{ °C} \pm 1\text{ °C}$ .

#### E.3 Test fuel

The test fuel is a mixture of 85 % by volume of liquid C (ISO 1817) and 15 % by volume of methanol.

#### E.4 Procedure

**E.4.1** Prepare and clean the copper strips in accordance with ASTM D130.

**E.4.2** Mount a copper strip (within 1 min of cleaning) and a piece of inner liner material in the specimen holder and place in the test tube.

**E.4.3** Add 200 ml of test fuel to cover the test specimen, attach the water condenser, and place in the water bath for 168 h.

**E.4.4** Examine and evaluate the copper strip in accordance with ASTM D130. Report the level of tarnishing and any presence of crystalline material.

## **Annex F** **(normative)**

### **Life-cycle test**

#### **F.1 General**

This annex describes a life-cycle test carried out to ensure that the materials and construction of fuel hoses and tubing will meet the functional requirements of the fuel system when exposed to pressure, vibration, and temperature cycles.

#### **F.2 Apparatus**

**F.2.1 Suitable test chamber**, capable of meeting the requirements of SAE J2044:2002, 6.5. As the test requires the heating of fuel under conditions of flow and pressure, the chamber shall be housed in a suitable explosion-proof facility.

#### **F.3 Procedure**

The test shall be conducted in accordance with SAE J2044:2002, 6.5 (life-cycle test), except the elevated-temperature segment of each cycle shall be carried out at 80 °C for type 1 hoses and tubing, 100 °C for type 2 hoses and tubing, and 125 °C for type 3 hoses and tubing.

## Annex G (informative)

### Example of how a non-standard type of hose or tubing could be specified by an original equipment manufacturer (OEM) using a matrix

**Table H.1 — Hose to ISO 19013-2, Clause 5**

a	X
b	X
c	X
d	X
e	X
f	NA
g	NA
h	X
i1	NA
i2	NA
i3	X
i4	NA
i5	NA
i6	X
j	NA
k	NA
l	X
m	X
n1 to n8	X
o	X
p	NA
q	NA
r	X
s	X
z1	X
z2	X
Where z1, z2, ... , etc., denote additional tests as specified by the OEM.	
X test required.	
NA test not applicable.	

## Annex H (normative)

### Type tests

[Table H.1](#) gives the tests to be carried out for type testing as defined in [Clause 6](#).

**Table I.1 — Type test**

Test (see <a href="#">Clause 5</a> )	Applicability			
	Type 1	Type 2	Type 3	Type 4
a	X	X	X	X
b	X	X	X	X
c	X	X	X	X
d	X	X	X	X
e	X	X	X	X
f	X	X	X	X
g	X	X	X	X
h	X	X	X	X
i1	X	NA	NA	X
i2	NA	X	NA	NA
i3	NA	NA	X	NA
i4	X	NA	NA	X
i5	NA	X	NA	NA
i6	NA	NA	X	NA
j	NA	X	X	NA
k	NA	X	X	NA
l	X	X	X	X
m	X	X	X	X
n1 to n8	X	X	X	X
o	X	X	X	X
p	X	X	X	X
q	X (RP only)	X (RP only)	X (RP only)	X (RP only)
r	X	X	X	X
s	X	X	X	NA

X test shall be carried out.  
NA test not applicable.



## Annex I (normative)

### Routine tests

[Table I.1](#) gives the tests to be carried out for routine testing as defined in [Clause 6](#).

**Table I.1 — Routine test**

Test	Applicability
Dimensions	X
Concentricity	X
<a href="#">Clause 5</a> tests:	
a	NA
b	NA
c	NA
d	NA
e	NA
f	NA
g	NA
h	NA
i	NA
j	NA
k	NA
l	NA
m	NA
o	NA
p	NA
q	NA
r	NA
s	NA
X test shall be carried out.	
NA test not applicable.	

## Annex J (informative)

### Production acceptance tests

[Table J.1](#) gives the suggested frequency for production tests to be carried out per batch or 10 batches. A batch is defined as 1 000 m of hose or tubing produced.

**Table J.1 — Recommended frequency for production test**

Test	Per batch	Per 10 batches
Dimensions	X	X
Concentricity	X	X
<a href="#">Clause 5</a> tests:		
a	X	X
b	X	X
c	X	X
d	X	X
e	X	X
f	X	X
g	NA	X
h	NA	X
i (168 h tests)	NA	X
j	NA	NA
k	NA	NA
l	X	X
m	X	X
n	NA	NA
o	NA	X
p	NA	NA
q	X	X
r	NA	X
s	NA	NA
X test is carried out.		
NA test not applicable.		



