

INTERNATIONAL STANDARD

ISO 18909

First edition
2006-07-15

Photography — Processed photographic colour films and paper prints — Methods for measuring image stability

*Photographie — Films et papiers photographiques couleur traités —
Méthodes de mesure de la stabilité de l'image*



Reference number
ISO 18909:2006(E)

© ISO 2006

PDF disclaimer

This PDF file may contain embedded typefaces. In accordance with Adobe's licensing policy, this file may be printed or viewed but shall not be edited unless the typefaces which are embedded are licensed to and installed on the computer performing the editing. In downloading this file, parties accept therein the responsibility of not infringing Adobe's licensing policy. The ISO Central Secretariat accepts no liability in this area.

Adobe is a trademark of Adobe Systems Incorporated.

Details of the software products used to create this PDF file can be found in the General Info relative to the file; the PDF-creation parameters were optimized for printing. Every care has been taken to ensure that the file is suitable for use by ISO member bodies. In the unlikely event that a problem relating to it is found, please inform the Central Secretariat at the address given below.

© ISO 2006

All rights reserved. Unless otherwise specified, no part of this publication may be reproduced or utilized in any form or by any means, electronic or mechanical, including photocopying and microfilm, without permission in writing from either ISO at the address below or ISO's member body in the country of the requester.

ISO copyright office
Case postale 56 • CH-1211 Geneva 20
Tel. + 41 22 749 01 11
Fax + 41 22 749 09 47
E-mail copyright@iso.org
Web www.iso.org

Published in Switzerland

Contents

Page

Foreword.....	v
Introduction	vi
1 Scope	1
2 Normative references	1
3 Test methods — General	1
3.1 Sensitometric exposure	1
3.2 Processing.....	2
3.3 Densitometry	3
3.4 Definition of density terms	3
3.5 Density values to be measured	3
3.6 Method of correction of density measurements for d_{\min} changes	3
3.7 Computation of image-life parameters	8
3.8 Effects of dye fading and stain formation on the printing quality of colour negative images.....	9
4 Test methods — Dark stability	10
4.1 Introduction	10
4.2 Test conditions	10
4.3 Number of specimens	11
4.4 Test equipment and operation for specimens free-hanging in air	11
4.5 Test equipment and operation for specimens sealed in moisture-proof bags	12
4.6 Conditioning and packaging of specimens in moisture-proof bags	12
4.7 Incubation conditions for specimens sealed in moisture-proof bags	12
4.8 Computation of dark stability	12
5 Test methods — Light stability	12
5.1 Introduction	12
5.2 Number of specimens	13
5.3 Irradiance measurements and normalization of test results.....	13
5.4 Backing of test specimens during irradiation testing.....	13
5.5 Specification for standard window glass	14
5.6 High-intensity filtered xenon arc ID65 illuminant (50 klx to 100 klx) for simulated indoor indirect daylight through window glass	14
5.7 Glass-filtered fluorescent room illumination — Cool White fluorescent lamps (80 klx or lower).....	16
5.8 Incandescent tungsten room illumination 3,0 klx – CIE illuminant A spectral distribution.....	18
5.9 Simulated outdoor sunlight (xenon arc) 100 klx – CIE D65 spectral distribution	18
5.10 Intermittent tungsten-halogen lamp slide projection 1 000 klx	21
5.11 Computation of light stability	21
6 Test report	21
6.1 Introduction	21
6.2 Dark stability tests	23
6.3 Light stability tests	24
Annex A (informative) Numbering system for related International Standards.....	25
Annex B (informative) A method of interpolation for step wedge exposures.....	27
Annex C (informative) Method for power equation d_{\min} correction of reflection print materials.....	28
Annex D (informative) Illustration of Arrhenius calculation for dark stability	33

Annex E (informative) The importance of the starting density in the assessment of dye fading and colour balance changes in light-stability tests	37
Annex F (informative) Enclosure effects in light-stability tests with prints framed under glass or plastic sheets.....	39
Annex G (informative) Data treatment for the stability of light-exposed colour images.....	41
Bibliography	49

.....

Foreword

ISO (the International Organization for Standardization) is a worldwide federation of national standards bodies (ISO member bodies). The work of preparing International Standards is normally carried out through ISO technical committees. Each member body interested in a subject for which a technical committee has been established has the right to be represented on that committee. International organizations, governmental and non-governmental, in liaison with ISO, also take part in the work. ISO collaborates closely with the International Electrotechnical Commission (IEC) on all matters of electrotechnical standardization.

International Standards are drafted in accordance with the rules given in the ISO/IEC Directives, Part 2.

The main task of technical committees is to prepare International Standards. Draft International Standards adopted by the technical committees are circulated to the member bodies for voting. Publication as an International Standard requires approval by at least 75 % of the member bodies casting a vote.

Attention is drawn to the possibility that some of the elements of this document may be the subject of patent rights. ISO shall not be held responsible for identifying any or all such patent rights.

ISO 18909 was prepared by Technical Committee ISO/TC 42, *Photography*.

This first edition cancels and replaces ISO 10977:1993, of which it constitutes a technical revision.

Introduction

This International Standard is one of a series of standards dealing with the physical properties and stability of imaging materials. To facilitate identification of these documents, they are assigned a number within the block from 18900 – 18999 (see Annex A).

This International Standard is divided into two parts. The first covers the methods and procedures for predicting the long-term, dark storage stability of colour photographic images; the second covers the methods and procedures for measuring the colour stability of such images when exposed to light of specified intensities and spectral distribution, at specified temperatures and relative humidities.

Today, the majority of continuous-tone photographs are made with colour photographic materials. The length of time that such photographs are to be kept can vary from a few days to many hundreds of years and the importance of image stability can be correspondingly small or great. Often the ultimate use of a particular photograph may not be known at the outset. Knowledge of the useful life of colour photographs is important to many users, especially since stability requirements often vary depending upon the application. For museums, archives, and others responsible for the care of colour photographic materials, an understanding of the behaviour of these materials under various storage and display conditions is essential if they are to be preserved in good condition for long periods of time.

Organic cyan, magenta and yellow dyes that are dispersed in transparent binder layers coated on to transparent or white opaque supports form the images of most modern colour photographs. Colour photographic dye images typically fade during storage and display; they will usually also change in colour balance because the three image dyes seldom fade at the same rate. In addition, a yellowish (or occasionally other colour) stain may form and physical degradation may occur, such as embrittlement and cracking of the support and image layers. The rate of fading and staining can vary appreciably and is governed principally by the intrinsic stability of the colour photographic material and by the conditions under which the photograph is stored and displayed. The quality of chemical processing is another important factor. Post-processing treatments, such as application of lacquers, plastic laminates and retouching colours, may also affect the stability of colour materials.

The two main factors that influence storage behaviour, or dark stability, are the temperature and relative humidity of the air that has access to the photograph. High temperature, particularly in combination with high relative humidity, will accelerate the chemical reactions that can lead to degradation of one or more of the image dyes. Low-temperature, low-humidity storage, on the other hand, can greatly prolong the life of photographic colour images. Other potential causes of image degradation are atmospheric pollutants (such as oxidizing and reducing gases), micro-organisms and insects.

Primarily the intensity of the illumination, the duration of exposure to light, the spectral distribution of the illumination, and the ambient environmental conditions influence the stability of colour photographs when displayed indoors or outdoors. (However, the normally slower dark fading and staining reactions also proceed during display periods and will contribute to the total change in image quality). Ultraviolet (UV) radiation is particularly harmful to some types of colour photographs and can cause rapid fading as well as degradation of plastic layers such as the pigmented polyethylene layer of resin-coated (RC) paper supports.

In practice, colour photographs are stored and displayed under varying combinations of temperature, relative humidity and illumination, and for different lengths of time. For this reason, it is not possible to precisely predict the useful life of a given type of photographic material unless the specific conditions of storage and display are known in advance. Furthermore, the amount of change that is acceptable differs greatly from viewer to viewer and is influenced by the type of scene and the tonal and colour qualities of the image.

After extensive examination of amateur and professional colour photographs that have suffered varying degrees of fading or staining, no consensus has been achieved on how much change is acceptable for various image quality criteria. For this reason, this International Standard does not specify acceptable end-points for fading and changes in colour balance. Generally, however, the acceptable limits are twice as wide

for changes in overall image density as for changes in colour balance. For this reason, different criteria have been used as examples in this International Standard for predicting changes in image density and colour balance.

Pictorial tests can be helpful in assessing the visual changes that occur in light and dark stability tests, but are not included in this International Standard because no single scene is representative of the wide variety of scenes actually encountered in photography.

In dark storage at normal room temperatures, most modern colour films and papers have images that fade and stain too slowly to allow evaluation of the dark storage stability simply by measuring changes in the specimens over time. In such cases, too many years would be required to obtain meaningful stability data. It is possible, however, to assess in a relatively short time the probable long-term fading and staining behaviour at moderate or low temperatures by means of accelerated ageing tests carried out at high temperatures. The influence of relative humidity also can be evaluated by conducting the high-temperature tests at two or more humidity levels.

Similarly, information about the light stability of colour photographs can be obtained from accelerated light-stability tests. These require special test units equipped with high-intensity light sources in which test strips can be exposed for days, weeks, months or even years, to produce the desired amount of image fading (or staining). The temperature of the specimens and their moisture content must be controlled throughout the test period, and the types of light sources must be chosen to yield data that can be correlated satisfactorily with those obtained under conditions of normal use.

Accelerated light stability tests for predicting the behaviour of photographic colour images under normal display conditions may be complicated by reciprocity failure. When applied to light-induced fading and staining of colour images, reciprocity failure refers to the failure of many dyes to fade, or to form stain. This even applies when dyes are irradiated with high-intensity versus low-intensity light, even though the total light exposure (intensity \times time) is kept constant through appropriate adjustments in exposure duration (see [1] in the Bibliography). The extent of dye fading and stain formation can be greater or smaller under accelerated conditions, depending on the photochemical reactions involved in the dye degradation, the kind of dye dispersion, the nature of the binder material, and other variables. For example, the supply of oxygen that can diffuse from the surrounding atmosphere into a photograph's image-containing emulsion layers may be restricted in an accelerated test (dry gelatin is an excellent oxygen barrier). This may change the rate of dye-fading relative to that which would occur under normal display conditions. The temperature and moisture content of the test specimen also influence the magnitude of reciprocity failure. Furthermore, light fading is influenced by the pattern of irradiation (continuous versus intermittent) as well as by light/dark cycling rates.

For all these reasons, long-term changes in image density, colour balance and stain level can be reasonably estimated only for conditions similar to those employed in the accelerated tests, or when good correlation has been confirmed between accelerated tests and actual conditions of use.

In order to establish the validity of the test methods for evaluating the dark and light stability of different types of photographic colour films and papers, the following product types were selected for the tests:

- a) colour negative film with incorporated oil-soluble couplers;
- b) colour negative motion picture pre-print and negative films with incorporated oil-soluble couplers;
- c) colour reversal film with incorporated oil-soluble couplers;
- d) colour reversal film with incorporated Fischer-type couplers;
- e) colour reversal film with couplers in the developers;
- f) silver dye-bleach film and prints;
- g) colour prints with incorporated oil-soluble couplers;
- h) colour motion picture print films with incorporated oil-soluble couplers;

- i) colour dye imbibition (dye transfer) prints;
- j) integral colour instant print film with dye developers;
- k) peel-apart colour instant print film with dye developers;
- l) integral colour instant print film with dye releasers.

The results of extensive tests with these materials showed that the methods and procedures of this International Standard can be used to obtain meaningful information about the long-term dark stability and the light stability of colour photographs made with a specific product. They also can be used to compare the stability of colour photographs made with different products and to assess the effects of processing variations or post-processing treatments. The accuracy of predictions made on the basis of such accelerated ageing tests will depend greatly upon the actual storage or display conditions.

It must also be remembered that density changes induced by the test conditions and measured during and after the tests include those in the film or paper support and in the various auxiliary layers that may be included in a particular product. With most materials, however, the major changes occur in the dye image layers.

Stability when stored in the dark

The tests for predicting the stability of colour photographic images in dark storage are based on an adaptation of the Arrhenius method described by Bard *et al.* (see [2] and [3] in the Bibliography) and earlier references by Arrhenius, Steiger and others (see [4], [5], and [6] in the Bibliography). Although this method is derived from well-understood and proven theoretical precepts of chemistry, the validity of its application for predicting changes of photographic images rests on empirical confirmation. Although many chromogenic-type colour products yield image-fading and staining data in both accelerated and non-accelerated dark ageing tests that are in good agreement with the Arrhenius relationship, some other types of products do not.

NOTE For example, integral-type instant colour print materials often exhibit atypical staining at elevated temperatures; treatment of some chromogenic materials at temperatures above 80 °C and 60 % RH may cause loss of incorporated high-boiling solvents and abnormal image degradation; and the dyes of silver dye-bleach images deaggregate at combinations of very high temperature and high relative humidity, causing abnormal changes in colour balance and saturation (see [7] in the Bibliography). In general, photographic materials tend to undergo dramatic changes at relative humidities above 60 % (especially at the high temperatures employed in accelerated tests) owing to changes in the physical properties of gelatine.

Stability when exposed to light

The methods of testing light stability in this International Standard are based on the concept that increasing the light intensity without changing the spectral distribution of the illuminant or the ambient temperature and relative humidity should produce a proportional increase in the photochemical reactions that occur at typical viewing or display conditions, without introducing any undesirable side effects.

However, because of reciprocity failures that are discussed in this Introduction, this assumption does not always apply. Thus, the accelerated light stability test methods described in this International Standard are valid at the specified accelerated test conditions, but may not reliably predict the behaviours of a given product in long-term display under normal conditions.

Translucent print materials, designed for viewing by either reflected or transmitted light (or a combination of reflected and transmitted light), shall be evaluated as transparencies or as reflection prints, depending on how they will be used. Data shall be reported for each condition of intended use.

This International Standard does not specify which of the several light stability tests is the most important for any particular product.

Photography — Processed photographic colour films and paper prints — Methods for measuring image stability

1 Scope

This International Standard describes test methods for determining the long-term dark storage stability of colour photographic images and the colour stability of such images when subjected to certain illuminants at specified temperatures and relative humidities.

This International Standard is applicable to colour photographic images made with traditional, continuous-tone photographic materials with images formed with dyes. These images are generated with chromogenic, silver dye-bleach, dye transfer, and dye-diffusion-transfer instant systems. The tests have not been verified for evaluating the stability of colour images produced with dry- and liquid-toner electrophotography, thermal dye transfer (sometimes called dye sublimation), ink jet, pigment-gelatine systems, offset lithography, gravure and related colour imaging systems.

This International Standard does not include test procedures for the physical stability of images, supports or binder materials. However, it is recognized that in some instances, physical degradation such as support embrittlement, emulsion cracking or delamination of an image layer from its support, rather than image stability, will determine the useful life of a colour film or print material.

2 Normative references

The following referenced documents are indispensable for the application of this document. For dated references, only the edition cited applies. For undated references, the latest edition of the referenced document (including any amendments) applies.

ISO 5-2:2001, *Photography — Density measurements — Part 2: Geometric conditions for transmission density*

ISO 5-3:1995, *Photography — Density measurements — Part 3: Spectral conditions*

ISO 5-4:1995, *Photography — Density measurements — Part 4: Geometric conditions for reflection density*

ISO 18911-2000, *Imaging materials — Processed safety photographic films — Storage practices*

3 Test methods — General

3.1 Sensitometric exposure

The photographic material shall be exposed and processed in accordance with the manufacturer's recommendations to obtain areas (patches) of uniform density at least 5 mm × 5 mm. This International Standard requires measuring the changes in colour densities in minimum density areas (d_{\min}) and at a density of $1,0 \pm 0,05$ above d_{\min} . These changes are to be monitored in neutral areas, i.e. where the initial red, green and blue densities are approximately equal (above their respective d_{\min}), as well as in areas selectively

exposed to produce the purest possible cyan, magenta and yellow dye scales¹⁾. These shall be made with the aid of appropriate filters (see Table 1).

The desired density may be obtained from a single precise exposure or from a continuous wedge exposure. Alternatively, if it is more convenient (e.g. with automated densitometry), the starting densities of 1,0 above d_{min} may be interpolated from other densities (one way to do this is described in Annex B).

Table 1 — Suitable filters for exposing test specimens

Type of material ^a	Filters to generate (e.g. Kodak Wratten filters ^b or Fuji filters ^c)		
	Cyan dye	Magenta dye	Yellow dye
Reversal and direct positive	Minus red	Minus green	Minus blue
	Wratten 44 Fuji SP-5	Wratten 32 Fuji SP-4 or SP-12	Wratten 12 Fuji SC-50 or SC-52
Negative working	Red	Green	Blue
	Wratten 29 Fuji SC-62	Wratten 99 Fuji BPN-55	Wratten 47B Fuji BPB-42

^a If materials to be tested have unusual spectral sensitivity characteristics, consult the manufacturer for filter recommendations.

^b *Kodak Filters for Scientific and Technical Uses*, Kodak Publication No. B-3, Eastman Kodak Company, Rochester, New York, USA; 1985. This information is given for the convenience of users of this International Standard and does not constitute an endorsement by ISO of the product named. Equivalent products may be used if they can be shown to lead to the same results.

^c *Fujifilm Filter "Optical,"* Fuji Photo Film Co., Ltd., Tokyo, Japan; 1993. This information is given for the convenience of users of this International Standard and does not constitute an endorsement by ISO of the product named. Equivalent products may be used if they can be shown to lead to the same results.

3.2 Processing

The sensitometrically exposed specimens shall be processed using the processing system of primary interest.

The processing chemicals and processing procedure can have a significant effect on the dark-keeping and/or light-keeping stability of a colour photographic material. For example, a chromogenic colour negative print paper processed in a washless or non-plumbed system with a stabilizer rinse bath instead of a water wash probably has stability characteristics that are different from the same colour paper processed in a conventional chemistry and a final water wash. Therefore, the specific processing chemicals and procedure shall be listed along with the name of the colour product in any reference to the test results.

Stability data obtained from a colour material processed in certain processing chemicals shall not be applied to the colour material processed in different chemicals, or using a different processing procedure. Likewise, data obtained from test specimens shall not be applied to colour materials that have been subjected to post-processing treatments (e.g. application of lacquers, plastic laminates or retouching colours) that differ from the treatments given to the test specimens.

1) Because of optical or chemical interactions, a neutral patch or a patch with a colour composed of a mixture of two dyes, e.g. red, green or blue, often exhibit stability effects that are different from pure cyan, magenta or yellow dye patches. This situation is particularly likely to occur when images are subjected to light fading.

3.3 Densitometry

Image density shall be measured with the spectral conditions specified for Status A densitometry (transparencies and reflection prints) and for Status M densitometry (negatives) as described in ISO 5-3.

Transmission density, D_T , (90° opal; $S: < 10^\circ$; s) shall be measured with an instrument complying with the geometric conditions described in ISO 5-2. Reflection density, D_R , (40° to 50° ; $S: 5^\circ$; s) shall be measured as described in ISO 5-4.

One of the problems encountered in densitometry is the instability of the measuring devices, especially during the course of long-term tests. Some of the components of densitometers that can change appreciably with age, as well as from one unit or batch to another, are the optical filters, the light sensors and the lamps. For example, the filters in many modern densitometers will deteriorate with age and must be replaced periodically, often within 2 y to 3 y. However, replacement filters of the same type frequently do not exactly match the original filters in spectral transmittance characteristics. Such changes in transmittance will cause unequal changes in the measured density values of dyes having different spectral absorption properties.

One way of dealing with such problems in a densitometer system is to keep standard reference specimens of each test product sealed in vapour-proof containers and stored at -18°C or lower. These specimens can be used to check the performance of the system periodically and to derive correction factors for different products as required (the calibration standards supplied with a densitometer are not adequate for this purpose).

3.4 Definition of density terms

d is the symbol for measured density;

D is the symbol for density corrected for d_{\min} .

3.5 Density values to be measured

The following densities of the specimens, prepared as described in 3.1, shall be measured before and after the treatment interval (see Figure 1):

(a) $d_{\min}(\text{R})_t$, $d_{\min}(\text{G})_t$, $d_{\min}(\text{B})_t$

the red, green and blue minimum densities of specimens that have been treated for time t , where t takes on values from 0 to the end of the test;

(b) $d_{\text{N}}(\text{R})_t$, $d_{\text{N}}(\text{G})_t$, $d_{\text{N}}(\text{B})_t$

the red, green and blue densities of neutral patches that initially had densities of 1,0 above d_{\min} and that have been treated for time t , where t takes on values from 0 to the end of the test;

(c) $d_{\text{C}}(\text{R})_t$, $d_{\text{M}}(\text{G})_t$, $d_{\text{Y}}(\text{B})_t$

the red, green and blue densities of cyan, magenta and yellow colour patches that initially had densities of 1,0 above d_{\min} and that have been treated for time t , where t takes on values from 0 to the end of the test.

3.6 Method of correction of density measurements for d_{\min} changes

3.6.1 General

The areas of minimum density of many types of colour photographs change with time during dark storage, and generally to a lesser extent also change on prolonged exposure to light during display or projection. Such changes most commonly take the form of density (stain) increases, usually yellowish in colour. However,

some materials, under certain conditions, may exhibit a loss in minimum density; e.g. colour negatives in dark storage.

For the purposes of this International Standard, changes in minimum density as measured in d_{min} patches, whether increases or losses, are assumed to have occurred equally at all density levels. Therefore, in order to determine accurately the amount of dye-fading that has taken place during testing or during storage and display, it is necessary to take into account the change in the d_{min} value (see Table 2).

Table 2 — Correction of density measurements for d_{min} changes^a

Type of material and test	Correction
Transmission materials in dark and light stability tests	Full d_{min} correction (for starting density of 1,0 above d_{min})
Reflection materials in dark and light stability tests	1/2 d_{min} correction (for starting densities of 0,7 to 1,0 above d_{min})
Reflection materials in dark and light stability tests (alternative method – see Annex C)	d_{min} correction by power equation
^a No correction is made for d_{min} changes when determining colour balance changes of neutral patches.	

Different methods of d_{min} correction are specified for transmission and reflection materials because multiple internal reflections affect the d_{min} density values obtained with reflection materials, but not those of transmission materials (see [8] and [9] in the Bibliography). Specifically, the multiple reflections within the image and auxiliary layers of a reflection material cause an increase in the measured value of the stain density, but have much less effect on the measured values of reflection densities in the range of 0,7 to 1,0 above d_{min} . It was determined empirically that one-half the change measured in the d_{min} value of reflection materials provides a reasonable approximation of the actual d_{min} contribution to measured reflection densities in the range of 0,7 to 1,0 above d_{min} .

For translucent materials the most common method of density measurement is transmission; however, these materials shall be measured by reflection if that is their intended use. Translucent materials with very high initial transmission d_{min} may show a loss of d_{min} with light or dark treatment. In these cases, the use of half d_{min} correction may confound the measurements and caution must be used.

An alternative method for d_{min} correction using a multi-power relationship among stain, dye and measured densities is described in Annex C. This method is particularly useful for the correction of measured densities when relatively high stain levels are present and/or when measuring low-density levels below 0,7.

Two examples are described in a) and b) to help clarify the d_{min} correction procedures (illustrated in Figure 1 for transmission materials and Figure 2 for reflection materials).

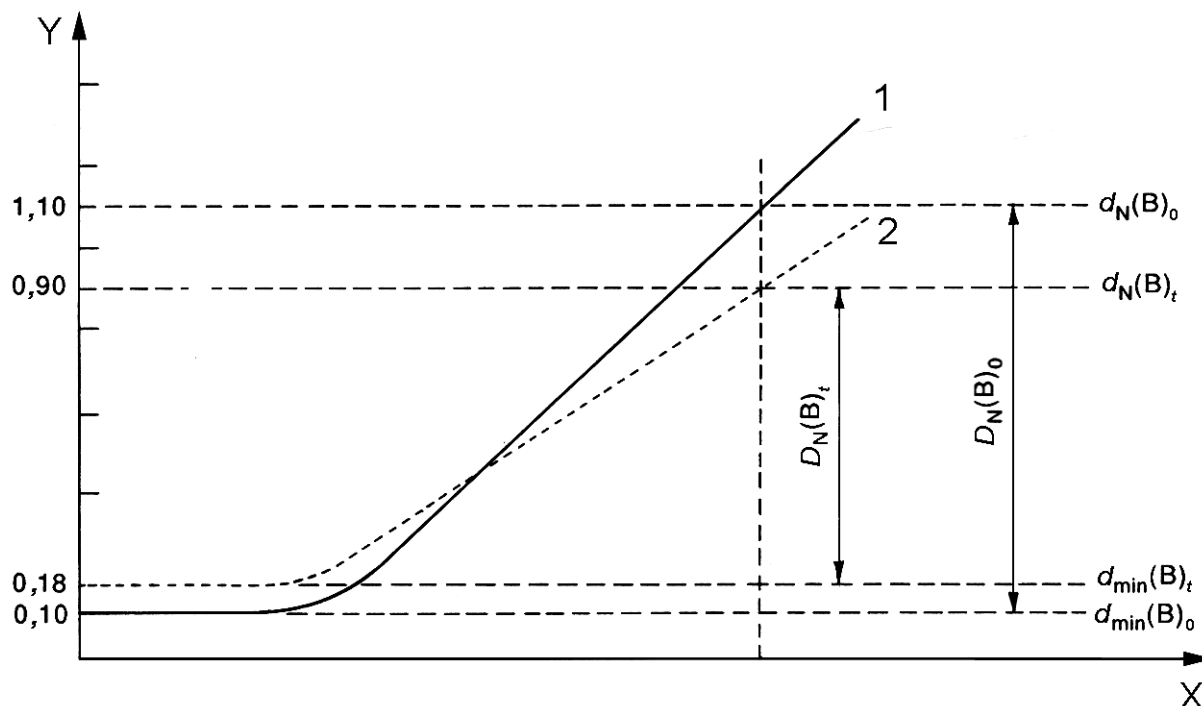
**Key**

- X log of exposure
 Y transmission density
 1 before testing
 2 after testing

Figure 1 — Illustration of the blue transmission density of a neutral patch of a transparency-type colour material (as defined by equations in 3.6.2)

- a) A colour transparency material tested for dark stability had a neutral patch with a starting blue density $D_N(B)_0$ of 1,0 since:

$$d_N(B)_0 = 1,1$$

$$d_{\min}(B)_0 = 0,1, \text{ and therefore}$$

$$D_N(B)_0 = [d_N(B)_0 - d_{\min}(B)_0] = 1,1 - 0,1 = 1,0$$

After incubation for time t , the blue density $D_N(B)_t$ was 0,72 because the measured density values had changed as follows:

$$d_N(B)_t = 0,90$$

$$d_{\min}(B)_t = 0,18, \text{ and therefore}$$

$$D_N(B)_t = [d_N(B)_t - d_{\min}(B)_t] = 0,90 - 0,18 = 0,72$$

Hence, the blue density of the neutral patch decreased by 0,28, whereas that of the minimum density patch increased (due to formation of yellowish stain) by 0,08. If the d_{\min} value had increased less, or even decreased (as can occur with colour negative films, for example), the value of $d_N(B)_t$ would have changed by a different, commensurate amount. However, by subtracting the d_{\min} density from the density of the neutral patch, both before and after incubation, the actual change in density of the neutral patch is determined. Similar procedures are employed to correct the cyan, magenta and yellow patches for d_{\min} changes.

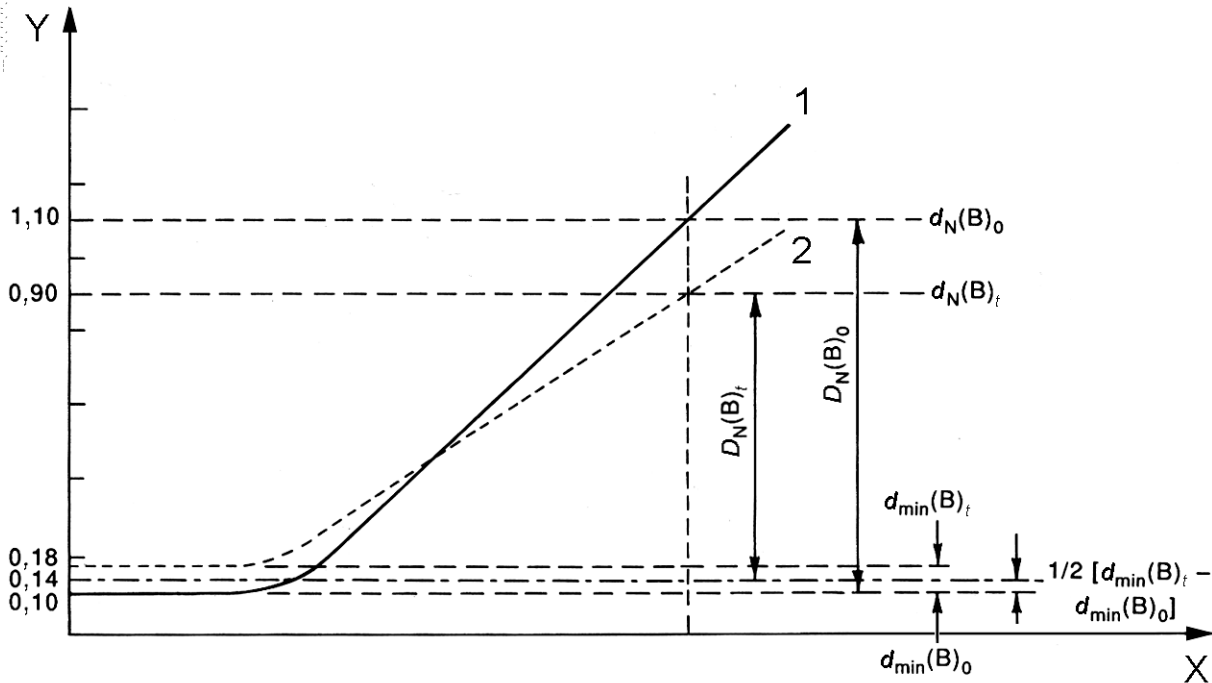

Key

- X log of exposure
- Y reflection density
- 1 before testing
- 2 after testing

Figure 2 — Illustration of the blue reflection density of a neutral patch of a reflection-type colour material (as defined by equations in 3.6.3)

b) A colour reflection print material tested for dark stability had a neutral patch with a starting blue density $D_N(B)_0$ of 1,0 since:

$$d_N(B)_0 = 1,1$$

$$d_{\min}(B)_0 = 0,1, \text{ and therefore}$$

$$D_N(B)_0 = [d_N(B)_0 - d_{\min}(B)_0] = 1,1 - 0,1 = 1,0$$

After incubation for time t , the blue density $D_N(B)_t$ was 0,76 because the measured density values had changed as follows:

$$d_N(B)_t = 0,90$$

$$d_{\min}(B)_t = 0,18, \text{ and therefore}$$

$$D_N(B)_t = d_N(B)_t - d_{\min}(B)_t + \frac{1}{2} [d_{\min}(B)_t - d_{\min}(B)_0] = 0,90 - 0,18 + \frac{1}{2} (0,18 - 0,10) = 0,72 + 0,04 = 0,76$$

Hence, the blue density of the neutral patch decreased by 0,24, whereas that of the minimum density patch increased (due to formation of yellowish stain) by 0,08. However, this increase in the measured d_{\min} value was due in part to the effects of multiple internal reflections, as explained in 3.5. Therefore, a correction was made equal to $+\frac{1}{2}$ the measured change of 0,08. Such a correction of $+\frac{1}{2} d_{\min}$ change would also have to be made if the d_{\min} value had decreased rather than increased. Similar procedures are employed to correct the cyan, magenta and yellow patches for d_{\min} changes.

NOTE The gradient of the two curves of Figure 2 was deliberately lowered in order to provide a clearer view of the density relations defined in the equation.

3.6.2 Transmission density corrected for d_{\min}

$$a) D_N(R)_t = d_N(R)_t - d_{\min}(R)_t$$

$$b) D_N(G)_t = d_N(G)_t - d_{\min}(G)_t$$

$$c) D_N(B)_t = d_N(B)_t - d_{\min}(B)_t$$

$$d) D_C(R)_t = d_C(R)_t - d_{\min}(R)_t$$

$$e) D_M(G)_t = d_M(G)_t - d_{\min}(G)_t$$

$$f) D_Y(B)_t = d_Y(B)_t - d_{\min}(B)_t$$

3.6.3 Reflection density corrected for d_{\min}

$$a) D_N(R)_t = d_N(R)_t - d_{\min}(R)_t + 1/2 [d_{\min}(R)_t - d_{\min}(R)_o]$$

$$b) D_N(G)_t = d_N(G)_t - d_{\min}(G)_t + 1/2 [d_{\min}(G)_t - d_{\min}(G)_o]$$

$$c) D_N(B)_t = d_N(B)_t - d_{\min}(B)_t + 1/2 [d_{\min}(B)_t - d_{\min}(B)_o]$$

$$d) D_C(R)_t = d_C(R)_t - d_{\min}(R)_t + 1/2 [d_{\min}(R)_t - d_{\min}(R)_o]$$

$$e) D_M(G)_t = d_M(G)_t - d_{\min}(G)_t + 1/2 [d_{\min}(G)_t - d_{\min}(G)_o]$$

$$f) D_Y(B)_t = d_Y(B)_t - d_{\min}(B)_t + 1/2 [d_{\min}(B)_t - d_{\min}(B)_o]$$

NOTE The d_{\min} correction for reflection density is identical to that for transmission density, except that it includes a back correction equal to one half the d_{\min} gain.

3.6.4 Colour balance in a neutral density patch

These are calculated as the percent of the average density.

$$a) d_N(R-G)_t = \frac{d_N(R)_t - d_N(G)_t}{0,5[d_N(R)_t + d_N(G)_t]} \times 100 \%$$

$$b) d_N(R-B)_t = \frac{d_N(R)_t - d_N(B)_t}{0,5[d_N(R)_t + d_N(B)_t]} \times 100 \%$$

$$c) d_N(G-B)_t = \frac{d_N(G)_t - d_N(B)_t}{0,5[d_N(G)_t + d_N(B)_t]} \times 100 \%$$

3.6.5 d_{\min} changes

$$a) d_{\min}(R)_t - d_{\min}(R)_o$$

$$b) d_{\min}(G)_t - d_{\min}(G)_o$$

c) $d_{\min}(B)_t - d_{\min}(B)_o$

3.6.6 d_{\min} colour balance

a) $d_{\min}(R - G)_t = d_{\min}(R)_t - d_{\min}(G)_t$

b) $d_{\min}(R - B)_t = d_{\min}(R)_t - d_{\min}(B)_t$

c) $d_{\min}(G - B)_t = d_{\min}(G)_t - d_{\min}(B)_t$

3.7 Computation of image-life parameters

From the measured density values, five image-life parameters can be computed (see Figure 1 for transmission materials and Figure 2 for reflection materials). These image-life parameters and illustrative end-points are listed in Table 3.

Table 3 — Image-life parameters for which times shall be reported

Parameters	Illustrative end-points for positive colour transparencies and reflection colour images	Illustrative end-points for colour negative materials
Change in neutral patches of $D_N(R)$, $D_N(G)$, and $D_N(B)$ (d_{\min} corrected)	30 %	15
Change in colour patches of $D_C(R)$, $D_M(G)$, and $D_Y(B)$ (d_{\min} corrected)	30 %	15
Change in colour balance of neutral patch: % $D_N(R - G)$, % $D_N(R - B)$, and % $D_N(G - B)$ (not d_{\min} corrected)	15 %	15
Change in $d_{\min}(R)$, $d_{\min}(G)$, and $d_{\min}(B)$ in the d_{\min} patch	0,10 %	0,05
Change in colour balance: $d_{\min}(R - G)$, $d_{\min}(R - B)$ and $d_{\min}(G - B)$ in the d_{\min} patch	0,06 %	0,05
<p>NOTE The image-life parameters listed are the critical characteristics that have practical significance for the visual degradation of colour images; however, the numerical end-points given here are only illustrative. Each user of this International Standard shall select end-points for the listed parameters, which, in that user's judgement, are appropriate for the specific product and intended application. Selected end-points may be different for light and dark stability tests.</p>		

3.8 Effects of dye fading and stain formation on the printing quality of colour negative images

The printing quality of colour negative images is mainly governed by three factors:

- the colour printing densities of its image dyes;
- the overall contrast and the contrast balance of these images;
- the colour printing density of the masking dyes and the stain.

Any change in these properties, whether due to dye fading, changes in dye morphology or discolouration of residual substances, has a greatly amplified effect on the final image because most colour print materials have high inherent contrast. The most damaging change tends to be contrast balance distortions brought about by differential fading of the three image dyes. These manifest themselves as shifts in colour balance from highlights to shadows that are especially noticeable in a scale of neutrals; e.g. a shift from magenta to green due to light-fading of the negative's magenta image dye, or from yellow to blue (colour negatives) or cyan to red (recent generations of colour negatives) due to dark-fading of the yellow or cyan dye. Generally, the acceptable deviation from essentially equal contrast values of all three dye images varies from 0,10 to 0,15, depending on the scene content, on the inherent contrast values of the negative and associated positive material, and on the conditions under which the print image is viewed. For instance, the tolerance of colour shifts is much smaller with reflection prints viewed in normal surround conditions than with projected images viewed in a dark room.

The second most consequential change is that caused by an increase in stain (discolouration of residual colour couplers and/or residual processing chemicals, etc.) and/or fading of masking dyes. This is so because the combined colour density of the stain and masking dyes governs the colour and density of low-density image areas and non-image areas of the negative and, thereby, its printing filter balance. They also affect the colour balance in high-density image areas. Changes in the d_{\min} colour balance of colour negatives of more than 0,05 result in appreciable changes in the colour balance of prints unless compensating adjustments are made in the ratios of blue, green and red exposure of the print materials. The required compensation usually is determined with colour analysers as part of the overall evaluation of the printing characteristics of individual or related sequences of images. The output of such colour analysis systems is used to control print exposures directly in automatic printers, and indirectly in manual or semi-automatic printers.

Depending on the magnitude of the d_{\min} imbalance, the colour rendition in shadow areas of the print image may vary from acceptable to unacceptable. Usually a change of 15 % in d_{\min} balance borders on the unacceptable.

The printing densities of colour negative image dyes usually change as a result of dark fading rather than light fading, because normally only a few prints are made from original camera negatives and this involves only modest aggregate exposure to light. This is true with most still-camera negative films and is also true with most motion picture camera colour negative films, because the latter serve only as masters for the generation of a small number of intermediate colour negative films. It is these motion picture intermediate films, which often are used to print large numbers of positive release prints, and the release prints themselves which may receive appreciable light exposure.

The dark-fading of image dyes typically results in a proportional loss of density at all density levels, without significant changes in spectral absorption. The practical effect of such change is a loss in image contrast. Contrast losses of up to 0,15 are tolerable with many scenes, provided that reasonable grey balance is maintained throughout the tone scale.

4 Test methods — Dark stability

4.1 Introduction

Long-term dark stability is evaluated by a series of tests carried out at several elevated temperatures at a particular relative humidity. Where practical, a useful relative humidity at which to test is 50 %.

Two test methods, known as the sealed-bag and the free-hanging methods, are available for accelerated dark stability testing. These test methods, which simulate two kinds of storage conditions, tend to give somewhat different results (see [10] in the Bibliography). In one, the photographic material is stored in a sealed container with very little air. Any substance released by the photographic material is trapped inside the container and can interact with the image or support. For example, with cellulose acetate base motion picture films stored in closed metal or plastic film cans, the fading of the dye images may be accelerated by the presence of acetic acid generated by the degradation of the acetate film base. This condition is best simulated by the sealed-bag method, in which preconditioned specimens are sealed in a moisture-proof bag from which most of the air has been expelled. An appropriate number of such bags is placed in ovens maintained at different test temperatures to permit specimen evaluation at periodic intervals until at least one predetermined end-point has been reached for the image-life parameters listed in Table 3.

The second storage condition is simulated by the free-hanging method, in which the specimens are suspended in a relatively large test chamber at a sufficient distance from each other to ensure free access of the circulating air to all surfaces.

The choice of test method shall be based on the known properties of the photographic materials being evaluated and the expected storage conditions of these materials. For example, motion picture films normally are stored in closed metal or plastic cans and, therefore, should be evaluated with the sealed-bag method. This method also provides a better simulation of the storage environment of still-camera colour films placed in plastic sleeves in strip or roll form as well as when the films are stored in roll form. However, the free-hanging method usually is more representative of the keeping conditions for mounted 35 mm and 6 cm × 6 cm colour slides and reflection colour prints.

4.2 Test conditions

At least four different temperatures shall be used at any one humidity level. The temperature range shall be at least 20 °C, preferably wider, and the temperature intervals shall be approximately equal, e.g. 55 °C, 65 °C, 75 °C, and 85 °C. The tolerance shall be ± 0,5 °C. The lower the temperature, the closer the approximation to normal storage conditions but the longer the time required to reach the image-life parameter end-points chosen for the test.

In general, a relative humidity of 50 % is used for these tests. The relative humidity of the test shall be maintained within ± 5 % RH of the aim value. Because the effects of humidity on image stability can differ markedly from one product to another, it is useful to evaluate its effect. This is done by means of a temperature test series carried out at different relative humidities.

If the relative humidity during storage is expected to be significantly lower than 50 % RH, such as when stored in accordance with ISO 18911 or in an arid climate, or significantly higher, as in a tropical climate, the relative humidity selected for the test shall correspond to the storage conditions. Such tests are often conducted at 30 % RH or 70 % RH.

At relative humidities above 50 %, misleading results may be obtained, especially at the high temperatures employed in accelerated tests, because of significant changes in the physical and/or chemical properties of some components of photographic imaging layers. For example, photographic gelatine changes from a sol to a gel state (glass transition temperature, T_g) at about 50 °C and 50 % RH. In the gel state, the structure and distribution of the image and masking dyes may change with consequent changes in spectral absorption and/or covering power. An example of this is the de-aggregation of the dyes in silver dye-bleach images which occurs at above 60 % RH and 70 °C. This causes changes in hue and colour density. Another example is the initial increase in density of some masking dyes in colour negative films due to physical changes, followed by a density decrease due to chemical transformation into colourless species (see [11] in the Bibliography). This multiple mechanism may come into play only in accelerated ageing tests and, if so, precludes accurate

predictions of ageing behaviour under normal storage conditions. Furthermore, ferrotyping and other physical defects may be induced at elevated temperatures and humidities.

Disproportionate increases or decreases in density values and/or pronounced changes in the appearance of the test specimens usually indicate the deleterious effects of high temperature treatment. Data derived from such specimens shall be excluded from the computation of the test results.

The user of this International Standard shall be aware that the moisture content (by weight) of the specimens would differ somewhat with the two test methods, especially at the highest oven temperatures (see [12] in the Bibliography). With the sealed-bag method, the moisture content of the specimens will remain essentially constant, irrespective of oven temperature (the relative humidity, however, generally will increase). With the free-hanging method, the actual moisture content of the specimens will generally decrease somewhat as the temperature of the ovens is increased (this is true even though the relative humidity of the air inside the ovens is maintained at the same level at all temperatures). The influence of these differences in specimen moisture content and the glass transition temperature of the gelatine emulsion on predictions of ageing behaviour may vary depending on the photographic material, the range of oven temperatures employed and the selected relative humidity value. If, with a particular photographic material, it is suspected that small differences in specimen moisture content could have a significant impact on fading and/or staining behaviour, it may be useful to conduct tests with both methods.

4.3 Number of specimens

The specimens shall be representative of the products and modes of processing to be evaluated.

For the free-hanging test method, two specimens are required for each of at least four temperatures at a single humidity level (i.e. a minimum of eight specimens). The optical densities of these specimens are measured before incubation and at predetermined intervals thereafter, as the specimens are withdrawn from the temperature/humidity-controlled ovens. The same specimens are used throughout the test period.

For the sealed-bag test method, two specimens are required for each bag. A separate bag is needed for each of the multiple density measurements to be made during the entire test period, because specimens that have been withdrawn from an oven and removed from a bag must not be re-bagged and further incubated. The total number of specimens and bags required to evaluate a particular product will depend on the number of withdrawals from the ovens for measurement. This number will be determined by the inherent stability of the product, the number of test temperatures and relative humidities employed, and the end-points selected for the image-life parameters listed in Table 3. Withdrawal intervals of hours and days often are appropriate for the highest temperatures, and weeks or months for the lower temperatures.

Normally, measurements shall be made at five or more time intervals during a period that is long enough for fading and/or staining to reach beyond one or more selected end-points. Generally, the required time intervals at the lower temperatures can be deduced from the fading and staining rates observed at the two highest temperatures.

It is suggested that additional tests with identical specimens be repeated at different times to provide an indication of the repeatability of the test procedures and testing equipment.

4.4 Test equipment and operation for specimens free-hanging in air

Specimens must be free hanging in air of controlled temperature and relative humidity. Recirculating forced-air environmental chambers shall be used.

The use of desiccators containing aqueous solutions as humidity chambers was not investigated because this method of humidity control has several practical difficulties and because the aqueous solutions could lead to chemical contamination of the test specimens. For this reason, desiccators shall not be used for the tests specified in this International Standard. The atmospheric requirements stated above could be obtained with temperature- and humidity-controlled environmental chambers of the type in which the relative humidity is maintained by controlled contact of recirculated air with humidifying water.

4.5 Test equipment and operation for specimens sealed in moisture-proof bags

In addition to the test specimens used for measurements, additional pieces of processed films or print material (density is not critical) of the same kind shall be prepared to be used as fillers for heat-sealed bag incubations. Recirculating forced-air ovens of controlled temperature shall be used.

4.6 Conditioning and packaging of specimens in moisture-proof bags

Prior to incubation, the two test specimens and all the pieces of filler film shall be conditioned to $23\text{ °C} \pm 2\text{ °C}$ and the relative humidity of the test for at least 24 h prior to incubation. RC (polyethylene coated) papers and pieces of filler paper should be conditioned for at least 10 d prior to incubation.

The two test specimens for each incubation condition shall be sandwiched in between seven pieces of filler specimens of the same kind (more realistic predictions in confined storage are achieved by placing more filler specimens in the bag) and then be heat-sealed in a moisture-proof aluminium-foil-laminated bag after the air has been squeezed out. Film and paper specimens (and filler specimens) shall be arranged so that the emulsion side of each specimen faces the backside of the adjacent specimen. Double bagging shall be used to reduce any effect of pinholes in the aluminium foil layer of the bags.

Once specimens have been removed from a bag for making density measurements, the specimens shall not be subjected to further incubation.

4.7 Incubation conditions for specimens sealed in moisture-proof bags

The heat-sealed bags containing the film or print material specimens shall be incubated at the temperatures specified in 4.2. Because control of relative humidity within the test ovens is not necessary, dry ovens (which are much less expensive than humidity-controlled ovens) may be used.

4.8 Computation of dark stability

The mathematical procedures for estimating image life by the Arrhenius method are described in Annex D.

5 Test methods — Light stability

5.1 Introduction

Five different light stability tests are described in 5.6 to 5.10. These tests are intended to simulate common-use situations. Selection of the appropriate tests shall be based on the conditions of intended use and the starting density is an extremely important factor (see Annex E). In most homes, for example, indirect daylight through window glass is the principal illumination causing displayed photographs to fade.

The low-intensity illumination provided by incandescent tungsten lamps in homes usually contributes very little to the deterioration of colour photographs. Fluorescent lamps, however, which generally provide more intense illumination than tungsten lamps, are increasingly found in homes. When fluorescent lamps are present, they may make a significant contribution to the fading of displayed prints.

In offices and public buildings, fluorescent lamps are usually the primary source of illumination. Photography exhibits in galleries, museums and archives are most often illuminated with standard incandescent lamps or quartz-halogen tungsten lamps. Exposure to direct sunlight is the principal cause of fading in colour print materials displayed outdoors (e.g. billboards, outdoor displays and identification badges).

Colour materials generally exhibit at least some degree of reciprocity failure in high-intensity light stability tests, i.e. a material may fade or stain a different amount when exposed to high-intensity illumination for a short period than it does when exposed to lower-intensity illumination for a longer period – even though the total light exposure (intensity \times time) and the temperature and relative humidity are the same in both cases (see [1] in the Bibliography). The illumination level of 6,0 klx specified for the indoor indirect daylight test in 5.6 and the

fluorescent room illumination test in 5.7, and the 3,0 klx level specified for the incandescent tungsten test in 5.8, were chosen because they are of sufficient intensity to produce meaningful results within a reasonable length of time (i.e. about 1 y) with most colour print materials. Tests performed with illumination levels that more closely approximate normal indoor display conditions (e.g. 0,6 klx) would be more meaningful, but would require test periods of many years for most materials.

To determine if a material has a tendency to exhibit reciprocity failures in fading and staining behaviour in high-intensity tests, parallel tests shall be conducted at a lower intensity (e.g. 1,0 klx) with at least one of the specified indoor illumination sources.

When certain types of colour print are displayed for long periods, it has been found that whether the prints are framed (enclosed under glass or plastic sheets) or unframed (open to air) can have a significant effect on rates of dye fading and stain formation (see [1] in the Bibliography). This enclosure effect, which is described in Annex F, shall be considered when selecting light exposure test conditions.

5.2 Number of specimens

Two or more identical specimens are required for each of the tests to be performed. It is suggested that additional tests with identical specimens be repeated at staggered intervals to provide an indication of the repeatability of the test procedures and test equipment.

5.3 Irradiance measurements and normalization of test results

Irradiance levels shall be measured with a radiometer that has a spectral response that falls within $\pm 5\%$ throughout the CIE relative photopic luminosity curve. Wavelength distributions for the irradiance sources specified in this International Standard are defined in their respective tables.

NOTE The ultraviolet (UV) component of the radiation should conform as closely as possible to that specified for the spectral distribution of the relevant International Standard light source. However, this International Standard does not require that the UV radiation levels be adjusted to conform to the specified spectral distributions within fixed limits, because there is no simple way to make such adjustments without also affecting the intensity of the visible radiation.

It is important to note that UV radiation is considerably more harmful to some types of colour photographs than to others and, therefore, variations in the level (and spectral distribution) of the UV radiation in the illumination will affect some materials more than others. The test conditions specified in 5.9 (simulated outdoor sunlight) are particularly noteworthy in this regard, because the UV component of this illumination is large and an ultraviolet-absorbing glass provides only limited protection to the test specimens.

The intensity of the irradiance shall be monitored and recorded daily with a radiometer (or integrating radiometer) and maintained within $\pm 10\%$ of the specified starting value throughout the test period, but the deviations must be taken into account when determining the accumulated irradiation. The times reported to reach the test end-points shall be normalized to the standard klx level called for by the particular test²⁾. The times to reach the end-points shall be reported in the units of time that are deemed most appropriate for a particular test (i.e. minutes, days or years). The tests specified in 5.9 and 5.10 use cycling conditions that alternate between periods of light and dark; the times reported to reach the selected end-points shall include the illumination time only.

5.4 Backing of test specimens during irradiation testing

Prints shall be backed with a non-reactive and non-yellowing white material such as 100 % cotton cellulose mount board (100 % rag board) or metal (e.g. flame-sprayed, ceramic-coated steel plate). Specimen positions

2) A method of normalizing data to a standard illumination level (e.g. 6,0 klx) is:

corrected time equals actual time multiplied by measured source intensity in kiloluxes divided by 6,0.

Care should be taken that the difference between the normalized intensity and the actual intensity are not so different that reciprocity law failure becomes an issue. This is especially true for sources rich in UV.

in a light stability apparatus that are not occupied with actual test prints shall be filled with dummy specimens that have a reflectance approximately equal to that of the test specimens.

Transparencies shall have a black backing under all test conditions³⁾. In high-intensity tests, where thermal heating of the specimen and black-backing material may be significant, it is essential that temperature and relative humidity specifications be maintained.

Translucent print materials, designed for viewing by either reflected or transmitted light (or a combination of both), shall be evaluated in accordance with their intended application, and data shall be reported for each condition of intended use.

5.5 Specification for standard window glass

The window glass specified in the tests shall be a soda lime float glass with a thickness of $6,5 \text{ mm} \pm 0,5 \text{ mm}$ and having spectral transmission characteristics that closely conform to the values given in Table 4. In order to maintain conformance, it is recommended that the glass be cleaned as needed and replaced yearly (or sooner if the glass develops a visually detectable haze).

5.6 High-intensity filtered xenon arc ID65 illuminant (50 klx to 100 klx) for simulated indoor indirect daylight through window glass

Commercial xenon arc equipment is available in the range of 70 klx to 100 klx and some laboratories have constructed xenon arc equipment with a 50 klx capability. These units are being used for evaluation of materials in high-intensity illumination that simulates indoor indirect daylight through window glass. However, results obtained from equipment operating in this range of light intensities may vary among different test equipment because of differences in specimen temperature and moisture content during the course of tests. In addition, there is concern that reciprocity failures may occur with the use of such high-intensity illumination and the correlation with light stability behaviour under average indoor illumination conditions may be problematic. Reciprocity failures are especially likely to occur under constant-exposure high-intensity conditions. The temperature, relative humidity, and light/dark cycle times specified in Table 7 are strongly suggested for warm-running equipment. Excessive heat can potentially desiccate the specimens. These conditions have been found to better match the dye fading behaviour that occurs in commonly encountered indoor display conditions, involving hot/less-humid day time and cool/humid night time, as opposed to those in constant-exposure tests. It will be necessary in reporting results to stipulate the light intensity at the sample plane and whether the test unit used a cycle or constant irradiation.

The specimens shall be surrounded by air at $30 \text{ °C} \pm 5 \text{ °C}^4)$, maintained by an adequate airflow across the specimens; the ambient relative humidity shall be $50 \text{ \% RH} \pm 5 \text{ \% RH}$.

The test unit shall consist of a xenon arc lamp⁵⁾, or the equivalent, with a quartz burner tube assembly. In addition, two pieces of the standard window-glass filter (see 5.5) shall be inserted between the lamp unit and the test specimens. Some water-cooled xenon arc lamps are already equipped with a soda lime glass filter as

3) An example of an appropriate backing is Kodak Black Aero Leader 5986, Kodak Catalogue Number 159-9455. This information is given for the convenience of users of this International Standard and does not constitute an endorsement by ISO of the product named. Equivalent products may be used if they can be shown to lead to the same results.

4) Some commercial equipment can maintain the earlier and more stringent requirement of $24 \pm 2 \text{ °C}$ and these requirements may be used to maintain a data base.

5) Suitable xenon arc test equipment is available from Atlas Material Testing Technologies, L.L.C, 4114 North Ravenswood Avenue, Chicago, IL 60613, USA and from Q-Panel Lab Products, 800 Canterbury Rd., Cleveland, OH 44115, USA. This information is given for the convenience of users of this International Standard and does not constitute an endorsement by ISO of the product named. Equivalent products may be used if they can be shown to lead to the same results.

the outer glass for the water jacket⁶⁾. If this is the case, the glass filter shall be counted as one of the two window glass filters. The spectral distribution of the source shall conform closely to that given in Table 5⁷⁾.

Table 4 — Relative spectral transmittance of window glass^a

Wavelength nm	Relative spectral transmittance	Wavelength nm	Relative spectral transmittance	Wavelength nm	Relative spectral transmittance
300	0,0	475	99,9	650	94,2
305	0,0	480	100,0	655	94,0
310	0,0	485	100,2	660	93,7
315	0,1	490	100,4	665	93,4
320	0,9	495	100,4	670	93,2
325	4,6	500	100,5	675	92,9
330	13,5	505	100,6	680	92,6
335	27,6	510	100,7	685	92,3
340	43,9	515	100,7	690	92,0
345	59,2	520	100,7	695	91,5
350	71,7	525	100,6	700	91,2
355	80,4	530	100,6	705	90,8
360	86,7	535	100,5	710	90,5
365	90,8	540	100,5	715	90,1
370	92,7	545	100,5	720	89,6
375	91,2	550	100,4	725	89,3
389	89,7	555	100,2	730	88,5
385	92,3	560	100,0	735	88,4
390	95,6	565	99,8	740	87,9
395	97,5	570	99,6	745	87,6
400	98,5	575	99,2	750	87,1
405	98,7	580	98,9	755	86,6
410	98,3	585	98,5	760	86,1
415	97,9	590	98,1	765	85,8
420	97,8	595	97,7	770	85,3
425	97,8	600	97,5	775	84,9
430	97,8	605	97,2	780	84,4
435	97,7	610	96,9		
440	97,7	615	96,6		
445	98,0	620	96,3		
450	98,4	625	95,9		
455	98,8	630	95,6		
460	99,3	635	95,2		
465	99,6	640	94,9		
470	99,8	645	94,6		

NOTE Data are normalized to 100 at 560 nm.

^a See [21] in the Bibliography.

6) The water jacket of water-cooled xenon arc lamps generally consists of borosilicate or quartz inner glass and soda lime or borosilicate, outer glass. Unlike soda lime glass, both borosilicate and quartz glass have relatively high UV transmittance. Soda lime float glass is the most popular window glass.

7) The xenon arc units are designed to simulate the daylight spectrum, which contains a considerable amount of ultraviolet (UV) and infrared (IR) energy. Thus, it might be advantageous to monitor these units using a power unit (watts per square metre) rather than one of photopic intensity (lux). This is currently done for weathering of plastics, printed materials, automotive components and textiles. The energy at one wavelength (commonly 340 nm or 420 nm) is an acceptable measure for calibration of the lamp. It was of concern to this standards committee, however, that it does not indicate the total amount of energy impinging on the test specimens on the specimen plane of the fading unit. The conversion from lux (relatively easy to measure with a lux meter) to watts per square metre requires assumptions to be made about the wavelength range of interest. For these reasons, the intensity in lux and the power spectrum of the source are defined in this International Standard.

Table 5 — Relative spectral power distribution for simulated indoor indirect daylight ID65^a

Wavelength nm	Relative spectral power	Wavelength nm	Relative spectral power
300	0,0	600	87,0
310	0,0	610	86,1
320	0,4	620	83,4
330	9,8	630	80,9
340	21,3	640	77,8
350	32,6	650	76,2
360	41,9	660	75,1
370	45,6	670	73,9
380	49,1	680	70,1
390	59,6	690	66,2
400	73,8	700	64,3
410	86,5	710	61,3
420	87,7	720	60,2
430	89,1	730	59,8
440	100,4	740	59,9
450	111,4	750	52,6
460	115,7	760	49,6
470	115,8	770	48,9
480	113,0	780	53,3
490	111,3	790	50,8
500	108,7	800	47,2
510	107,3	810	44,9
520	106,7	820	44,7
530	105,5		
540	105,1		
550	102,3		
560	99,3		
570	96,3		
580	92,2		
590	89,6		

NOTE Data are smoothed by a piecewise running mean, taking each 10 nm interval value with its immediate neighbours.
See [22] in the Bibliography.

^a See [23] in the Bibliography.

5.7 Glass-filtered fluorescent room illumination — Cool White fluorescent lamps (80 klx or lower)

Fluorescent equipment for accelerated light stability tests is commonly operated with illumination in the 20 klx to 50 klx range. The specified Cool White fluorescent lamps (see Table 6) are available in two types: lamps now commonly used in homes and offices, manufactured with a low concentration of mercury vapour in an effort to reduce harm to the environment when the lamps are disposed of; for outdoor commercial applications in cold weather conditions, and in accelerated light fading tests, high output Cool White fluorescent lamps with higher mercury vapour content are preferable because they operate satisfactorily over a wide temperature range and their higher light intensity shortens test periods.

The light from both types of lamp has very similar spectral distributions. In running these tests the conditions of Table 7 shall be followed to prevent desiccation of test specimens. If the unit is cooled to ambient temperature and relative humidity, the effect of desiccation becomes minimal. When reporting the results, the light intensity at the sample plane and the type of irradiation, either cycling or constant, shall be stipulated.

To simulate display situations where prints or transparencies are subjected to direct, bare-bulb fluorescent illumination, the glass sheet may be omitted. Since glass does not absorb the 365 nm line in the fluorescent spectrum, it may be desirable to include Plexiglas™-filtered information as well. To satisfy the reporting requirements of this International Standard, part of the data-reporting step must be to stipulate which type of filter, if any, is used.

The specimens shall be surrounded by air at 23 °C ± 2 °C, maintained by an adequate airflow across the specimen; the ambient relative humidity shall be 50 % RH ± 5 RH %. One-half of the lamps shall be replaced after each 2 000 h of test equipment operation.

Table 6 — Relative spectral power distribution for F-6 Cool White fluorescent lamps^a

Wavelength nm	Relative spectral power	Wavelength nm	Relative spectral power	Wavelength nm	Relative spectral power
300	0,03	475	6,58	650	4,16
305	0,03	480	6,59	655	3,55
310	0,78	485	6,56	660	3,02
315	1,71	490	6,56	665	2,57
320	0,03	495	6,42	670	2,20
325	0,03	500	6,28	675	1,87
330	0,03	505	6,20	680	1,60
335	0,31	510	6,19	685	1,37
340	0,06	515	6,30	690	1,29
345	0,10	520	6,60	695	1,05
350	0,13	525	7,12	700	0,91
355	0,24	530	7,94	705	0,81
360	0,68	535	9,07	710	0,71
365	5,61	540	10,49	715	0,61
370	2,34	545	25,22	720	0,54
375	0,94	550	17,40	725	0,48
380	1,05	555	15,63	730	0,44
385	1,31	560	17,22	735	0,43
390	1,63	565	18,53	740	0,40
395	1,90	570	19,43	745	0,37
400	3,11	575	21,97	750	0,38
405	14,80	580	23,01	755	0,35
410	3,43	585	19,41	760	0,39
415	3,30	590	18,56	765	0,41
420	3,68	595	17,42	770	0,33
425	4,07	600	16,09	775	0,26
430	4,45	605	14,64	780	0,21
435	32,61	610	13,15		
440	10,74	615	11,68		
445	5,48	620	10,25		
450	5,78	625	8,95		
455	6,03	630	7,74		
460	6,25	635	6,69		
465	6,41	640	5,71		
470	6,52	645	4,87		

^a Source: Toshiba Corporation (300 nm to 375 nm); 380 nm to 780 nm. See [24] in the Bibliography.

Table 7 — Cycling conditions for high-intensity daylight, fluorescent and 100-klx outdoor daylight

Conditions	Light cycle	Dark cycle
Light/dark cycle duration	3,8 h	1,0 h
Chamber temperature	40 °C ± 5 °C	25 °C ± 5 °C
Chamber relative humidity	40 % RH ± 10 % RH	80 % RH ± 5 % RH
Black panel temperature	65 °C ± 10 °C	

NOTE The specimen temperature during periods of light exposure shall be at least 35 °C, but shall not exceed 60 °C; 40 °C is recommended. After the light periods, the specimen shall be cooled to 25 °C ± 5 °C within 15 min. One way to determine the specimen temperature is with Reatec temperature indicator strips⁸⁾, or their equivalent, placed on the front-side of the specimen.

5.8 Incandescent tungsten room illumination 3,0 klx – CIE illuminant A spectral distribution

The specimens shall be surrounded by air at 23 °C ± 2 °C, maintained by an adequate airflow across the specimen; the ambient relative humidity shall be 50 % ± 5 %.

Standard 75R30/FL or 150R/FL tungsten incandescent reflector-flood lamps giving an illuminance of 3 klx shall be used (see Table 8 for spectral distribution). Voltage shall be adjusted to maintain an illumination colour temperature of 2 856 K ± 100 K. A standard window-glass filter (see 5.5) shall be placed between the lamps and the specimen plane. Lamps shall be replaced after 2 000 h. To meet the reporting requirements of this International Standard, only data obtained from tests using standard incandescent tungsten lamps are acceptable.

NOTE With most colour photographic materials, the light fading and staining effects of glass-filtered quartz tungsten-halogen lamps are similar, but not identical, to those of standard incandescent lamps. Bare-bulb quartz tungsten-halogen lamps emit comparatively high levels of UV radiation, which will adversely affect the stability of some types of colour photograph.

5.9 Simulated outdoor sunlight (xenon arc) 100 klx – CIE D65 spectral distribution

The test unit shall be a xenon high-pressure arc lamp, or its equivalent, containing a quartz burner tube assembly with inner and outer borosilicate (e.g. Pyrex[®]) glass filters of 1,5 mm and 2,5 mm thickness giving an illuminance of 100 klx. An additional borosilicate glass filter of 6,0 mm thickness shall be positioned in front of the lamp, but the test specimens shall not be covered with glass.

The spectral power distribution given in Table 9 was chosen in an attempt to simulate D65; it is recognized, however, that the spectral match in the UV region is not ideal.

Suitable commercial test units are available that have the specified xenon-arc assembly and the controls for regulating the temperature and relative humidity of the air in the test chamber⁵⁾. However, the temperature of the specimens rises well above the air temperature when the specimens are illuminated continuously. This causes the moisture content of the specimens to fall and remain at very low levels throughout the test. Results obtained in this manner tend to be misleading, because photographs displayed outdoors are cycled between light and dark periods (i.e. day and night) and usually attain high moisture levels during the cooler dark intervals.

8) Reatec temperature indicator strips, manufactured in Switzerland [REATEC AG, Raubbuehlstrasse 15a, CH-8600 Duebendorf (ZH)], are supplied in the US by MRC, Inc., The Woods, Suite A-514, 985 Old Eagle School Road, Wayne, Pennsylvania 19087. This information is given for the convenience of users of this International Standard and does not constitute an endorsement by ISO of the product named. Equivalent products may be used if they can be shown to lead to the same results.

It is possible to simulate the effect of some outdoor conditions by designing the xenon-arc test to have light/dark cycles as defined in Table 7. Although the cycle pattern shown in Table 7 has longer light periods than dark periods, it provides good correlation with results obtained from outdoor tests.

Table 8 — Relative spectral power distribution for incandescent tungsten CIE Illuminant A^a

Wavelength nm	Relative spectral power	Wavelength nm	Relative spectral power	Wavelength nm	Relative spectral power	Wavelength nm	Relative spectral power
300	0,93	450	33,09	600	129,04	750	227,00
305	1,13	455	35,41	605	132,70	755	229,59
310	1,36	460	37,81	610	136,35	760	232,12
315	1,62	465	40,30	615	139,99	765	234,59
320	1,93	470	42,87	620	143,62	770	237,01
325	2,27	475	45,52	625	147,24	775	239,37
330	2,66	480	48,24	630	150,84	780	241,68
335	3,10	485	51,04	635	154,42	785	243,92
340	3,59	490	53,91	640	157,98	790	246,12
345	4,14	495	56,85	645	161,52	795	248,25
350	4,74	500	59,86	650	165,03	800	250,33
355	5,41	505	62,93	655	168,51	805	252,35
360	6,14	510	66,06	660	171,96	810	254,31
365	6,95	515	69,25	665	175,38	815	256,22
370	7,82	520	72,50	670	178,77	820	258,07
375	8,77	525	75,79	675	182,12	825	
380	9,80	530	79,13	680	185,43	830	259,86
385	10,90	535	82,52	685	188,70		261,60
390	12,09	540	85,95	690	191,93		
395	13,35	545	89,41	695	195,12		
400	14,71	550	92,91	700	198,26		
405	16,15	555	96,44	705	201,36		
410	17,68	560	100,00	710	204,41		
415	19,29	565	103,58	715	207,41		
420	20,99	570	107,18	720	210,36		
425	22,79	575		725	231,27		
430	24,67	580	110,80	730	216,12		
435	26,64	585	114,44	735	218,92		
440	28,70	590	118,08	740	221,67		
445	30,85	595	121,73	745	224,36		
			125,39				

NOTE Data are normalized to 100 at 560 nm.

^a Source: [25] in the Bibliography.

Table 9 — Relative spectral power distribution for outdoor daylight CIE illuminant D65^a

Wavelength nm	Relative spectral power	Wavelength nm	Relative spectral power	Wavelength nm	Relative spectral power	Wavelength nm	Relative spectral power
300	0,03	450	117,01	600	90,01	750	63,59
305	1,66	455	117,41	605	89,80	755	55,01
310	3,29	460	117,81	610	89,60	760	46,42
315	11,77	465	116,34	615	88,65	765	56,61
320	20,24	470	114,86	620	87,70	770	66,81
325	28,64	475	115,39	625	85,49	775	65,09
330	37,05	480	115,92	630	83,29	780	63,38
335	38,50	485	112,37	635	83,49	785	63,84
340	39,95	490	108,81	640	83,70	790	64,30
345	42,43	495	109,08	645	81,68	795	61,88
350	44,91	500	109,35	650	80,03	800	59,45
355	45,78	505	108,58	655	80,12	805	55,71
360	46,64	510	107,80	660	80,21	810	51,96
365	49,36	515	106,30	665	81,25	815	54,70
370	52,09	520	104,79	670	82,28	820	57,44
375	51,03	525	106,24	675	80,28	825	58,88
380	49,98	530	107,69	680	78,28	830	60,31
385	52,31	535	106,05	685	74,00		
390	54,65	540	104,41	690	69,72		
395	68,70	545	104,23	695	70,67		
400	82,75	550	104,05	700	71,61		
405	87,12	555	102,02	705	72,98		
410	91,49	560	100,00	710	74,35		
415	92,46	565	98,17	715	67,98		
420	93,43	570	96,33	720	61,60		
425	90,06	575	96,06	725	65,74		
430	86,68	580	95,79	730	69,89		
435	95,77	585	92,24	735	72,49		
440	104,86	590	88,69	740	75,09		
445	110,94	595	89,35	745	69,34		

NOTE Data are normalized to 100 at 560 nm.

^a Source: [25] in the Bibliography.

5.10 Intermittent tungsten-halogen lamp slide projection 1 000 klx

A slide projector equipped with a quartz tungsten-halogen lamp, infrared-transmitting mirror and an infrared-absorbing glass filter shall be used. Projectors equipped with xenon-arc lamps shall not be used.

Since the intensity of illumination tends to fall off somewhat in the corner areas of a slide projector film gate, the area of the film specimens to be measured shall be restricted to a 10 mm square in the centre of the slides.

The illumination level at the film plane may be measured with a selenium barrier-layer cell; the selenium cell shall be placed in the centre of the film gate during measurements⁷⁾. Lamps shall be operated at the nominal voltage level ($\pm 10\%$) specified by the manufacturer⁹⁾. A constant-voltage regulator shall be used if line voltage fluctuation during the test period is greater than $\pm 3\%$. Specimen temperature at the film plane shall not exceed 70 °C once the temperature has stabilized after at least 30 min of operating the test equipment.

Precision timing equipment (instead of a built-in projector timer) shall be used to control the illumination periods, and to take into account the interval required for the test equipment mechanism to move from one film specimen to the next. Film specimens shall be illuminated for one 15 s period each hour (total of 6 min of illumination each 24 h). Equipment shall be arranged so that between illumination periods the film specimens are protected from light and are surrounded by air at 23 °C \pm 2 °C and a relative humidity of 50 % \pm 5 %.

Reported data shall be normalized to the standard 1 000 klx illumination level that is computed from the measured illumination level of the particular equipment and lamp used for this test (see 5.3).

5.11 Computation of light stability

Treatment of densitometric data for light stability tests is illustrated in Annex G.

6 Test report

6.1 Introduction

The data from the various tests are reported as the times required for the photographic images to reach the chosen end-point values for the fading parameters, the staining parameters or both. Illustrative end-points are given in Table 3. The relative importance of each of these image-life parameters – and their respective end-points – will vary depending on the intended use of the film or print material, the subject matter of the photograph, and the requirements of the viewer. In most cases, it is only necessary to continue the tests long enough to determine the end-points for just a few of the parameters listed in Table 3. In any event, the time to reach the first end-point, the parameter to which that end-point applies, and the end-point values chosen for all of the other parameters listed in Table 3 shall be reported.

This International Standard does not specify broadly applicable acceptable end-points because the amount of image change that can be tolerated is subjective, and will vary with the product type and specific consumer or institutional requirements. Each user of this International Standard shall select end-points for the listed parameters, which, in that user's judgement, are appropriate for the specific product and intended application. Selected end-points may be different for light and dark stability tests.

It shall be noted also that predictions of the useful life of colour prints based on extrapolation from accelerated fading tests are problematic at best, because the dark and light fading conditions can vary greatly in actual practice. Consequently, dark as well as light fading reactions will contribute in varying proportion to the image degradation, depending on the levels of their destructive reactants and the duration of exposure. For instance,

9) The light output of quartz tungsten-halogen projector lamps of a given type may vary significantly from one lamp to another, even when the same manufacturer makes the lamps. To maintain a uniform light level when lamps are changed, the average light output of a representative group of at least five lamps operated at the nominal voltage should be determined. To make individual lamps conform to this average output level, the voltage should be adjusted as necessary with a variable transformer.

the rate of fading of images illuminated by low intensity light will be governed much more by dark fading reactions than that of brightly illuminated images.

At present, the most commonly used method of assessing the combined effects of dark and light fading is by simple addition of the two reactions, as illustrated in Figures 3 to 5. It is known that, because of the complex chemical reactions taking place, the addition mentioned above is an oversimplification. However, the concept is presented here for illustrative purposes and the true relationships have not, as yet, been determined. This method does not fully take into account the other possible causes of fading and stain formation, such as residual processing chemicals and aggressive oxidizing and reducing gases.

It is very important to consider both dark fading and light fading characteristics when evaluating the stability behaviour of colour prints displayed for long periods of time. Published data for photographs displayed in homes show a wide range of illumination intensities depending on home location, latitude, average cloud cover, architectural design, sizes and placement of windows and skylights, and the intensity and distance from displayed photographs of incandescent tungsten, tungsten-halogen and fluorescent lamps (see [1], [13], and [20] in the Bibliography). Interior light levels in homes averaged over a 12 h period may range from as low as 50 lx to higher than 2 000 lx. Published data for home displayed prints in the United States show levels of 150 lx or lower in areas where bright daylight is avoided (see [19] and [20] in the Bibliography).

Illumination levels of 450 lx and higher are commonly found in offices, public buildings, and retail and commercial display environments (see [1], [14], and [15] in the Bibliography). Illumination conditions recommended for museum display of photographs are lower than those generally encountered in homes and offices. For these reasons, Figures 3 to 5 cover a wide range of lighting conditions and clearly illustrate the increasing role of dark stability in overall print stability as the light level decreases.

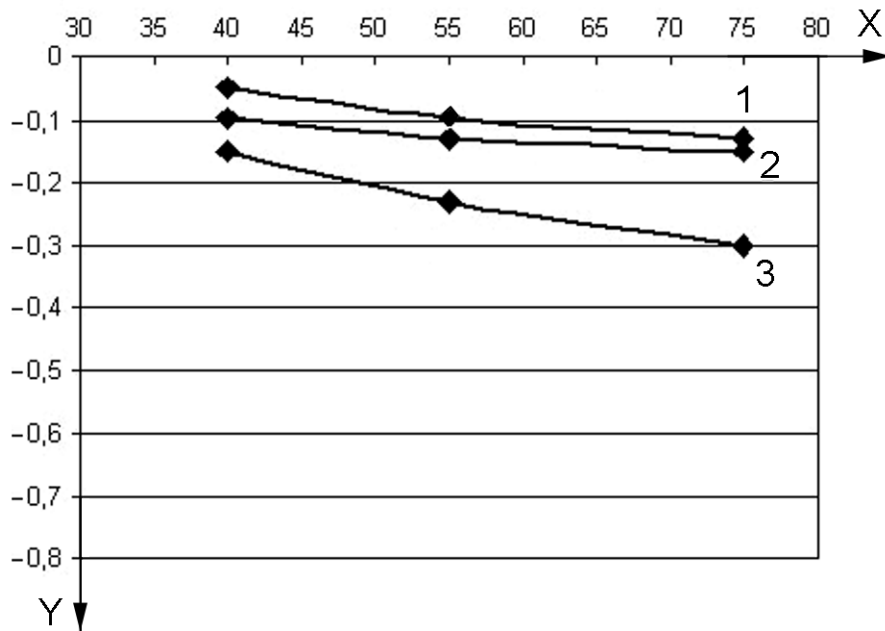

Key

- X years to a given fade
- Y loss from 1,0 density
- 1 120 lx
- 2 dark
- 3 dark + 120 lx

Figure 3 — Combination of light and dark fade at 120 lx

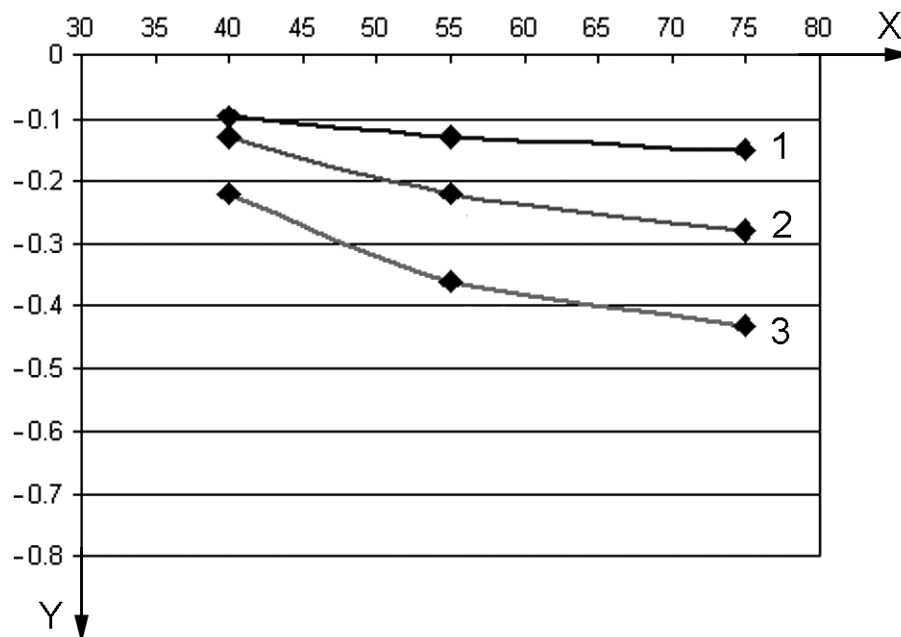
**Key**

X years for a given fade
 Y loss from 1,0 density

- 1 dark
- 2 250 lx
- 3 dark + 250 lx

Figure 4 — Combination of light and dark fade at 250 lx

6.2 Dark stability tests

The results of the tests are predictions of the times required for the photographic images to reach the specified fading end-points, the staining end-points or both, for the image-life parameters listed in Table 3 when the images are stored at particular conditions of temperature and humidity (e.g. 23 °C and 50 % RH).

The report of test results shall also include the following:

- starting densities (i.e. 1,0 above d_{\min}) of the neutral and colour patches;
- particular end-point values chosen for all of the image-life parameters listed in Table 3;
- relative humidity employed with the tests;
- temperatures employed with the tests;
- whether the sealed-bag or free-hanging test method was used.

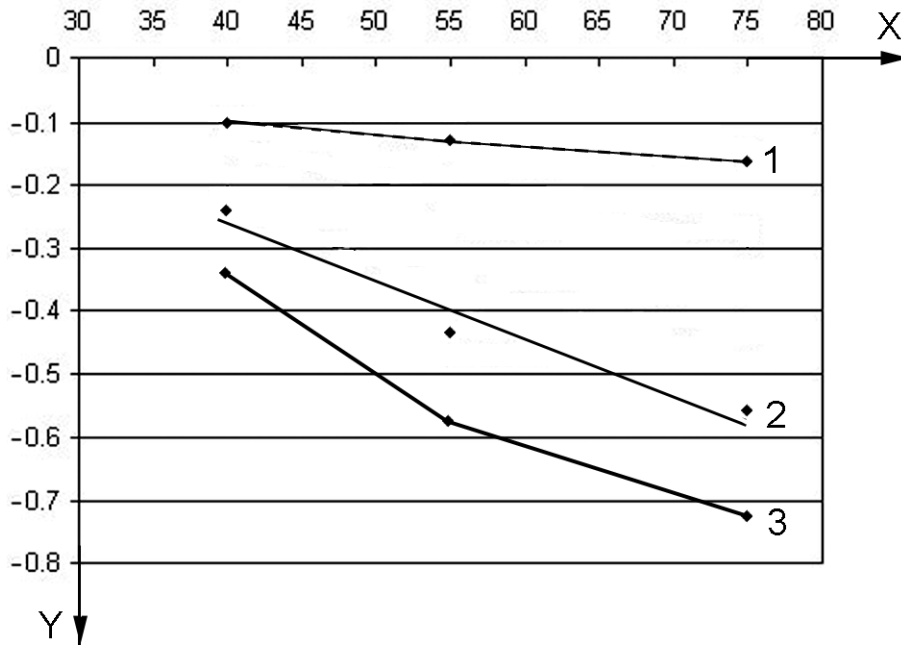

Key

- X years to a given fade
- Y loss from 1,0 density
- 1 dark
- 2 500 lx
- 3 dark + 500 lx

Figure 5 — Light and dark fade combination at 500 lx

6.3 Light stability tests

The report of test results shall include the following:

- type of test (e.g. simulated indoor indirect daylight; glass-filtered fluorescent room illumination; incandescent tungsten room illumination, etc.);
- if glass is used, the distance of the glass from the print, and whether or not the glass and the print are taped together along the edges to form a sealed enclosure;
- starting densities (i.e. 1,0 above d_{min}) of the neutral and colour patches in the test specimen;
- particular end-point values chosen for all of the image-life parameters listed in Table 3 and the time required for the specimen to reach the limiting end-point;
- whether the base or emulsion side of the material was facing toward the light (or the specific conditions selected if a combination of base-side and emulsion-side illumination was employed) for transparencies or translucent print materials intended for viewing with either reflected or transmitted light (or a combination of both);
- temperature and relative humidity at the specimen plane during the test (not required for the simulated outdoor sunlight test in 5.9 unless the temperature and relative humidity fall outside the ranges specified by the test).

Annex A (informative)

Numbering system for related International Standards

The current numbering system for TC 42 documents dealing with the physical properties and stability of imaging materials is confusing since the five-digit numbers that are used are not in any consecutive order. To facilitate remembering the numbers, ISO has set aside a block of numbers from 18900 to 18999 and all revisions and new International Standards will be given a number within this block. The last three digits will be identical to the current ANSI/PIMA numbers of published documents. This will be advantageous to the technical experts from Germany, Japan, United Kingdom and the USA who have prepared the standard and who are familiar with the ANSI/PIMA numbers.

As current International Standards are revised and published, their new numbers will be as given in Table A.1.

Table A.1 — New ISO numbers

Current ISO number	Title (New title)	(New) ISO number
10602	Photography (Imaging materials) — Processed silver-gelatin type black-and-white film (films) — Specifications for stability	(18901)
10214	Photography (Imaging materials) — Processed photographic materials (Processed photographic films, plates and papers) — Filing enclosures for storage (Filing enclosures and storage containers)	(18902)
6221	Photography (Imaging materials) — Films and papers (paper) — Determination of dimensional change	(18903)
5769	Photography (Imaging materials) — Processed films — Method for determining lubrication	(18904)
8225	Photography (Imaging materials) — Ammonia-processed diazo photographic film — Specifications for stability	(18905)
543	Photography (Imaging materials) — Photographic films — Specifications for safety film	(18906)
6077	Photography (Imaging materials) — Photographic films and papers — Wedge test for brittleness	(18907)
8776	Photography (Imaging materials) — Photographic film — Determination of folding endurance	(18908)
10977	Photography — Processed photographic colour films and paper prints — Methods for measuring image stability [<i>both current and new title</i>]	(18909)
4330	Photography — Determination of the curl of photographic film and paper (Imaging materials — Photographic film and paper — Determination of curl)	(18910)
5466	Photography (Imaging materials) — Processed safety photographic films — Storage practices	(18911)
9718	Photography (Imaging materials) — Processed vesicular photographic film — Specifications for stability	(18912)
	(Imaging materials — Permanence — Vocabulary)	(18913)
	(Imaging materials — Photographic film and papers — Method for determining the resistance of photographic emulsions to wet abrasion)	(18914)

Table A.1 (continued)

Current ISO number	Title (New title)	(New) ISO number
12206	Photography (Imaging materials) — Methods for the evaluation of the effectiveness of chemical conversion of silver images against oxidation	(18915)
14523	Photography (Imaging materials) — Processed photographic (imaging) materials — Photographic activity test for enclosure materials	(18916)
417	Photography — Determination of residual thiosulfate and other related chemicals in processed photographic materials — Methods using iodine-amylose, methylene blue and silver sulfide [<i>both current and new title</i>]	(18917)
3897	Photography (Imaging materials) — Processed photographic plates — Storage practices	(18918)
	(Imaging materials — Thermally processed silver microfilm — Specifications for stability)	(18919)
6051	Photography (Imaging materials) — Processed (photographic) reflection prints — Storage practices	(18920)
	(Imaging materials — Compact discs (CD-ROM) — Method for estimating the life expectancy based on the effects of temperature and relative humidity)	(18921)
	(Imaging materials — Processed photographic films — Methods for determining scratch resistance)	(18922)
	(Imaging materials — Polyester-base magnetic tape — Storage practices)	(18923)
	(Imaging materials — Test method for Arrhenius-type predictions)	(18924)
	(Imaging materials — Optical disc media — Storage practices)	(18925)
	(Imaging materials — Information stored on magneto-optical (MO) discs — Method for estimating the life expectancy based on the effects of temperature and relative humidity)	(18926)
	(Imaging materials — Recordable compact disc systems — Method for estimating the life expectancy based on the effects of temperature and relative humidity)	(18927)
10331	Photography (Imaging materials) — Unprocessed photographic films and papers — Storage practices	(18928)
	(Imaging materials — Wet-processed silver-gelatin type black-and-white photographic reflection prints — Specifications for dark storage)	(18929)
	(Imaging materials — Protocols for outdoor weathering experiments)	(TR 18930)
	(Imaging materials — Recommendations for humidity measurement and control)	(TR 18931)
	(Imaging materials — Adhesive mounting systems — Specifications)	(18932)
	(Imaging materials — Magnetic tape — Care and handling practices for extended usage)	(18933)
	(Imaging materials — Multiple media archives — Storage environment)	(18934)
	(Imaging materials — Colour images on paper prints — Determination of indoor water resistance of printed colour images)	(18935)
	(Imaging materials — Colour films and reflection colour prints — Methods for measuring thermal (dark) stability)	(18936)
	(Imaging materials — Reflection colour prints — Methods for measuring light stability)	(18937)
	(Imaging materials — Optical discs — Care and handling practices for extended usage)	(18938)

Annex B (informative)

A method of interpolation for step wedge exposures

If a step wedge is used to make the sensitometric exposure for the specimen, generally there will not be a step that is of exactly the desired density. For example, the densities of the two steps nearest to $d_{\min} + 1,0$ may be used to calculate the desired density by linear interpolation. After each fading time, the same coefficient is used for interpolating the density after fading.

First, on the unfaded strip, the step with the density d_1 just below $d_{\min} + 1,0$ and the step with the density d_2 just above $d_{\min} + 1,0$ are chosen (see Figure B.1). After fading, these two steps will have reached the densities $d_{1(t)}$ and $d_{2(t)}$. The density d_t of the initial $d = d_{\min} + 1,0$ is then estimated through linear interpolation as:

$$d_t = d_{1(t)} + [d_{2(t)} - d_{1(t)}]\alpha$$

where

$$\alpha = \frac{(d_{\min} + 1,0) - d_{1(t=0)}}{d_{2(t=0)} - d_{1(t=0)}}$$

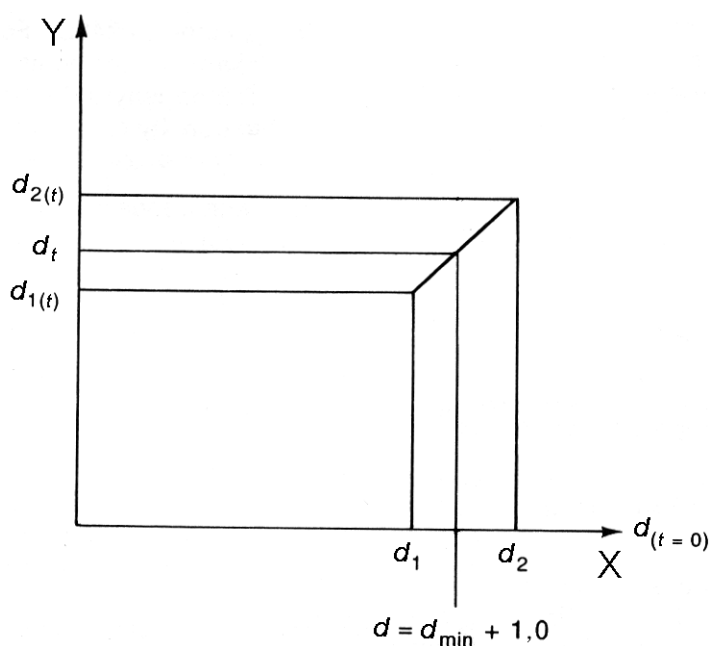

Key

- X density at time $t = 0$
- Y density at time t

Figure B.1 — Interpolation for step wedge exposures

Annex C (informative)

Method for power equation d_{\min} correction of reflection print materials

C.1 Introduction

This annex describes an alternative, more complex method for determining the d_{\min} corrected density of reflection print materials, and it is preferable to the procedure described in 3.6 when relatively high stain levels are present and/or when measuring dye patches with low starting densities. This method may also be preferable when considerable amounts of fading have taken place.

The basic equation for d_{\min} correction is expressed by a combination of multi-power terms; for this reason, the method is referred to as the power equation d_{\min} correction.

C.2 Background

The measured reflection density of a colour image on an opaque support is affected by surface reflections from the image layer and by multiple internal reflections from the support/image layer interface. In addition, the measured density may be affected by reflections from the inner surfaces and by scattering by localized non-uniformities in the multilayer structure of colour print materials. Taken together, these factors can result in a non-linear relationship between the amount of image dye that is actually present and the measured reflection density.

Because the deviation from linearity can be particularly significant in low density areas of an image, the $1/2 d_{\min}$ correction method, although recommended in 3.6, can induce considerable deviations from the net dye density (D_{dye}). These deviations are greatest when a low starting density is selected, when an image has faded a significant amount, and/or when a high stain density is present. Net dye density (D_{dye}) obtained by the power equation d_{\min} correction method is generally more accurate than that obtained by the $1/2 d_{\min}$ correction method. In actual practice, however, it has been found that the $1/2 d_{\min}$ correction method generally provides an adequate approximation.

C.3 Basic equation representing the relationship between D_{dye} , d_{dye} and d_{\min}

The net (corrected) dye density, D_{dye} , is obtained from the measured image density, d_{dye} , and the measured stain density, d_{\min} , by the following equation:

$$D_{\text{dye}}^n = d_{\text{dye}}^n - d_{\min}^n \quad (\text{C.1})$$

where n is 1,5 (a constant).

NOTE Strictly speaking, equation C.1 is valid only when D_{dye} , d_{dye} , and d_{\min} are all corrected for the base density. This is not required in this International Standard, however, because in most cases this induces only a small deviation. Consequently, D_{dye} , d_{dye} , and d_{\min} include base density.

The D_{dye} can be obtained either graphically (using Figure C.1) or by use of a computer or programmable calculator.

C.3.1 Graphical determination

The vertical and horizontal axes of Figure C.1 indicate D_{dye} and d_{min} respectively, and the series of curved dotted lines correspond to d_{dye} at various levels. The D_{dye} value is determined by the point on the vertical axis where the d_{dye} curve crosses the vertical d_{min} line.

For example, in a case where the measured densities are $d_{\text{dye}} = 0,9$ and $d_{\text{min}} = 0,5$, D_{dye} (or d_{min} corrected dye density) is obtained from the graph as follows:

- i) locate the vertical line for $d_{\text{min}} = 0,5$ and the curve for $d_{\text{dye}} = 0,9$;
- ii) locate the point where the line and curve cross; this gives the value for D_{dye} on the vertical axis as 0,63.

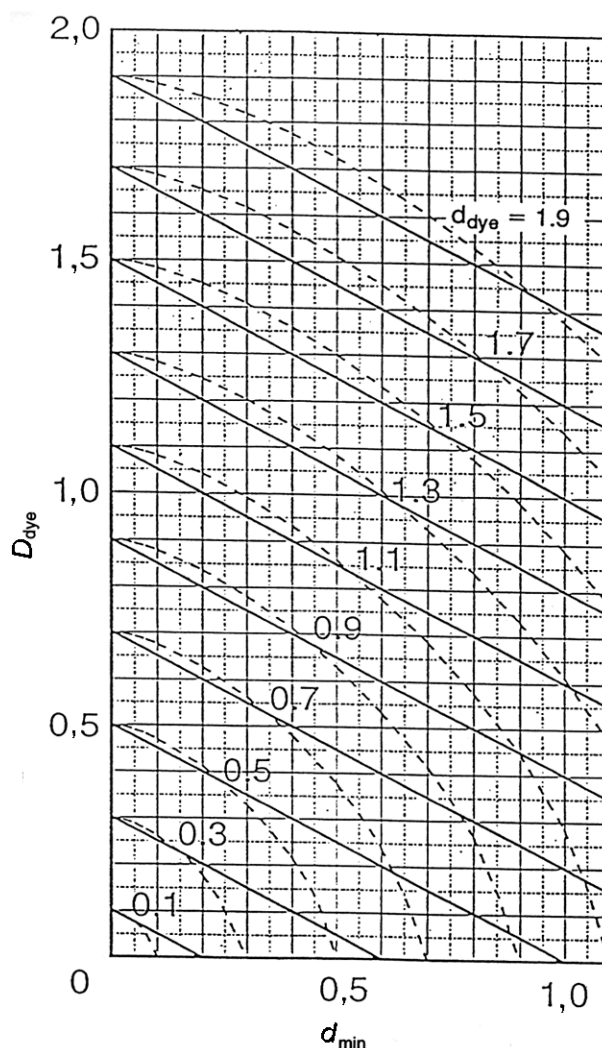

Key

———— = iso- d_{dye} lines for $\frac{1}{2} d_{\text{min}}$ correction

----- = iso- d_{dye} curves for the correction by power equation

NOTE The position of a point on the vertical axis indicates a d_{dye} value of a particular iso- d_{dye} line or curve originating from that point. D_{dye} is determined on the vertical axis by the position of the crosspoint of the iso- d_{min} line (curve) for the measured d_{dye} and the measured d_{min} .

Figure C.1 — The relationship of D_{dye} , d_{min} , and d_{dye} in reflection prints

C.3.2 Calculation using a computer or programmable calculator

The desired D_{dye} is obtained from the measured d_{min} and d_{dye} values using equation C.1 in C.3.

C.4 Comparison of the accuracy of full d_{min} correction, $1/2 d_{min}$ correction, and power equation d_{min} correction

Figure C.2 shows the accuracy of full d_{min} correction, $1/2 d_{min}$ correction, and power equation d_{min} correction methods in relation to the level of stain in the reflection print material. The relative error of the corrected densities obtained by $1/2 d_{min}$ correction falls within $\pm 5\%$ if d_{min}/d_{dye} does not exceed 0,6. If d_{min}/d_{dye} exceeds this level due to a high level of stain or low image density, power equation d_{min} correction should be used. For additional information on the derivation of Figure C.2, refer to the discussion by K. Takahashi (see [16] in the Bibliography).

NOTE The curve for full d_{min} correction is shown for the purpose of comparison. With this correction procedure, D_{dye} is obtained by subtracting d_{min} , instead of $1/2 d_{min}$ from d_{dye} . This is the normal procedure used for d_{min} correction of transmission density data.

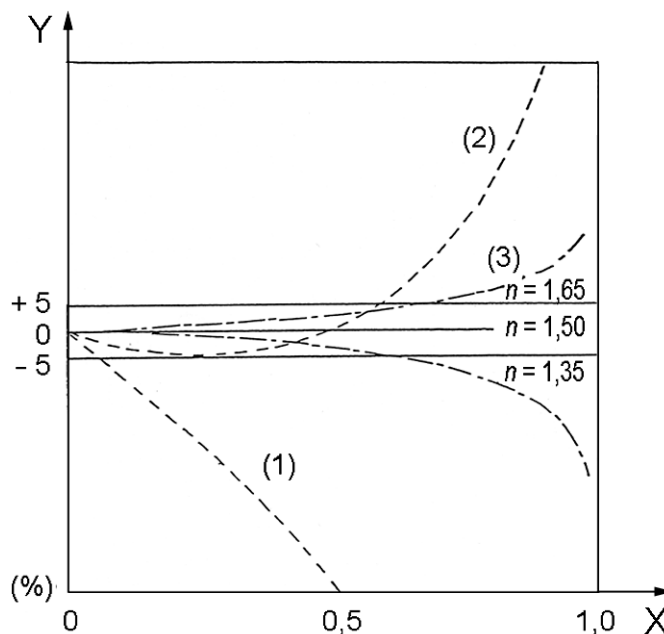

Key

- X $d_{min} + D_{dye}$
- Y relative accuracy of D_{dye} , $\{[(D_{dye})_{actual} - (D_{dye})_{corrected}] \div (D_{dye})_{actual}\}$
- 1 full d_{min} correction
- 2 $1/2 d_{min}$ correction
- 3 d_{min} correction with the power equation using $n = 1,35, 1,50$ and $1,65$

Figure C.2 — Comparison of d_{min} correction methods — Example 1

If the measured densities are $d_{\text{dye}} = 0,90$ and the $d_{\text{min}} = 0,45$, then the value of D_{dye} is 0,67 for both $\frac{1}{2} d_{\text{min}}$ correction and correction by the power equation, and it is almost the same value as the net D_{dye} . The $\frac{1}{2} d_{\text{min}}$ correction (dashed line) gives over-corrected D_{dye} at lower values of d_{min} and under-corrected D_{dye} at higher values of d_{min} , while d_{min} correction with the power equation (solid line) gives close to the exact value of D_{dye} at any d_{min} level.

Figure C.3 shows the relationship of D_{dye} versus d_{min} for the three methods of d_{min} correction at two levels of density D_{dye} . In both Figure C.2 and C.3, the true D_{dye} is considered to be located close to $n = 1,5$ (see [3] and [4] in the Bibliography).

Curve (3) for $n = 1,50$ coincides with the values shown by Pinnney and Vogelsong (see [9] in the Bibliography).

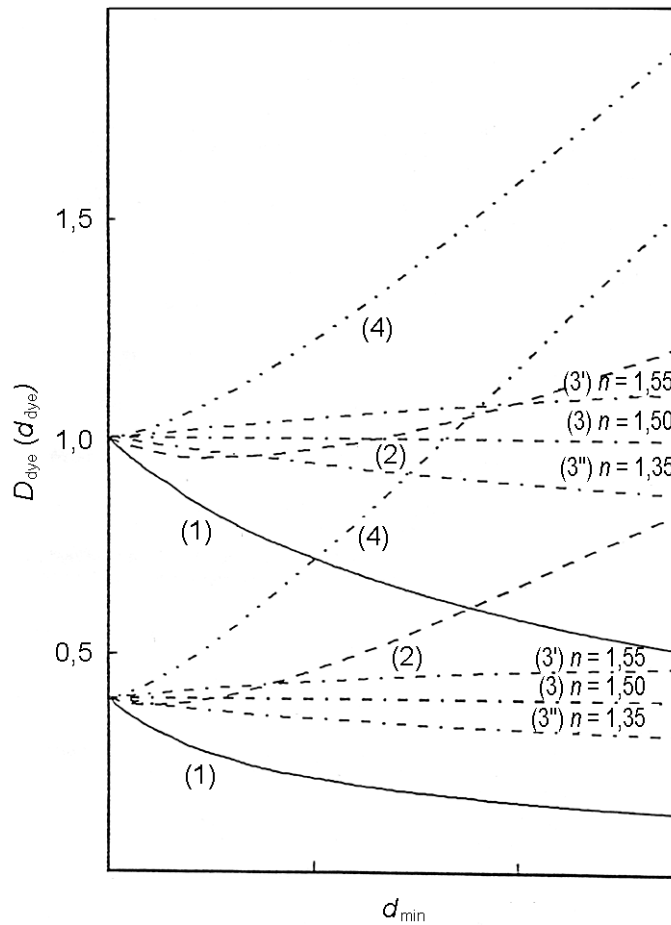

Key

- 1 full d_{min} correction
- 2 $\frac{1}{2} d_{\text{min}}$ correction
- 3 d_{min} correction with the power equation using $n = 1,35, 1,50$ and $1,65$
- 4 measured d_{dye}

Figure C.3 — Comparison of d_{min} correction methods — Example 235 principle of D_{dye} determination

C.5 Principle of D_{dye} determination

In order to determine D_{dye} , which is the analytical density of the imaging dye, the measured reflection density has to be transformed to transmission density because in a transmission system a linear relationship exists between D_{dye} , d_{dye} and d_{min} .

F.C. Williams and F.R. Clapper derived an integral equation expressing the relationship between reflection density and transmission density, taking surface and inner layer multi-reflection into account (see [17] in the Bibliography). Although the authors provided a basic theory of reflection versus transmission density transformation, they did not show the correctness of fit of the equation to actual measured densities.

J.E. Pinney and W.F. Vogelsong empirically determined a reflection density versus transmission density curve and discussed a mathematical transformation of the former to the latter (see [9] in the Bibliography).

N. Ohta further investigated the factors affecting the Williams-Clapper equation and provided an improved equation which precisely reproduces the Pinney-Vogelsong empirical curve by substituting suitable surface and inner reflection factors (see [18] in the bibliography). Unfortunately, the Ohta equation is too complicated to use for routine applications.

K. Takahashi found that the Ohta equation can be replaced by a linear combination of multi-power terms with a high degree of accuracy and, consequently, that the relationship between D_{dye} , d_{dye} , and d_{min} is expressed by equation 1 (see [16] in the Bibliography). Takahashi confirmed that the value of n in this equation is 1,50 for the empirical reflection versus transmission density relationship determined by Pinney and Vogelsong and, subsequently, by the Ohta equation.

C.6 Notes on the value of n

Although the value of n that accurately reproduces the reflection/transmission relationship in Pinney and Vogelsong's and Ohta's articles is 1,50, Takahashi found that this value can vary from product to product, and also varies among different types of support materials. For example:

- $n = 1,35$ for a thermal process dye diffusion transfer print (Fuji Pictrostat);
- $n = 1,43$ for a colour paper support (glossy resin-coated paper);
- $n = 1,55$ for a thermal dye transfer print (video printer);
- $n = 1,65$ for a dye diffusion transfer (instant) print.

These and other data indicate that the value of n for reflection print materials may vary by $\pm 10\%$, depending upon the specific type of product. However, the effect of the difference in n on the calculated D_{dye} value is not significant; therefore, the value of 1,50 for n can be applied to all reflection print materials (see Figures C.2 and C.3).

Annex D (informative)

Illustration of Arrhenius calculation for dark stability

D.1 Plot of colour fading

This annex illustrates the Arrhenius calculation using as an example the fading of a yellow colour patch in a transparency and the resulting densities after incubation at 60 °C and 50 % RH. The required density parameters can be found in Table D.1 for generating the fading curve at 60 °C. They are as follows:

- $d_{\min}(B)_t$, the measured blue d_{\min} at time t for the 60 °C oven condition; the time, t , in the oven ranged from 0 d to 266 d;
- $d_y(B)_t$, the measured density of the yellow colour patch to blue light at time t .

Table D.1 — Densitometry data for transmission material in a 60 °C/50 % RH oven

Time, t s	$d_y(B)_t$	$d_{\min}(B)_t$	$D_y(B)_t$
0	1,12	0,12	1,00
14	1,18	0,19	0,99
28	1,18	0,20	0,98
42	1,17	0,21	0,96
56	1,17	0,22	0,95
70	1,17	0,23	0,94
90	1,14	0,24	0,90
112	1,14	0,25	0,89
133	1,11	0,26	0,85
161	1,08	0,26	0,82
196	1,03	0,27	0,76
231	0,99	0,28	0,71
266	0,95	0,28	0,67

NOTE $D_y(B)_t = d_y(B)_t - d_{\min}(B)_t$

Densitometry of the yellow patches gives densities to blue light at each of the times t , $[d_y(B)_t]$. These densities include both the density due to the presence of the yellow dye and also the blue density of the support and other miscellaneous colourants. To correct for the densities of the miscellaneous colourants at each time t , the d_{min} densities are subtracted from the densities of the test patches to give $D_y(B)_t$, i.e.,

— for transmission materials

$$D_y(B)_t = d_y(B)_t - d_{min}(B)_t$$

— for reflection print materials

$$D_y(B)_t = d_y(B)_t - d_{min}(B)_t + \frac{1}{2}[d_{min}(B)_t - d_{min}(B)_0]$$

The initial density (before fading) of the yellow colour patch was chosen experimentally so that the $D_y(B)_0 = 1,0$.

$D_y(B)_t$ is plotted in Figure D.1 against the time, t , in days. A smooth curve is then drawn manually through the points. The same procedure is applied to the data from all temperatures. From these plots, one can interpolate the times required for the fading or decreasing of the original density $D_y(B)_0$ to reach a specified value, such as 0,3 density units for each of the temperatures. In this example, the values of the time, $t^{0,3}$ [at which $D_y(B)_t = 0,70$ density units] are determined from the plot (Figure D.1). These times are estimated from Figure D.1 to be as shown in Table D.2. These times, $t^{0,3}$, at each temperature are then used to make the Arrhenius plot.

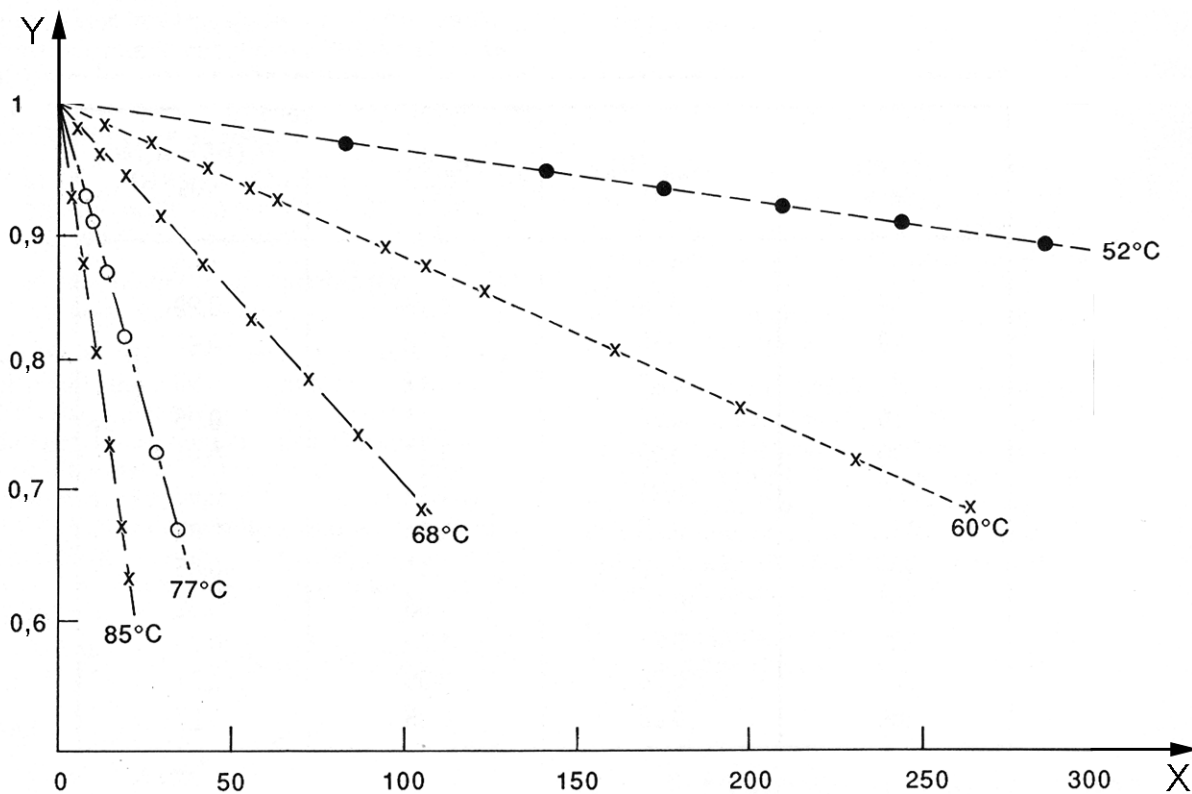

Key

X time, t , in days

Y $D_y(B)_t$

NOTE Initial d_{min} corrected blue density was 1,0, i.e. $D_y(B)_0 = 1,0$

Figure D.1 — d_{min} corrected blue density of the yellow colour patch of a transmission material

Table D.2 — Data for Arrhenius plot

Temperature °C	Time $t^{-0,3}$ ^a
85	18
77	40
68	95
60	240

^a Time to lose 0,30 in density from an initial d_{\min} corrected density of 1,00 (or, from Figure D.1, the time required for $D_y(B)_t = 0,70$).

D.2 The Arrhenius plot

An Arrhenius plot is now made from the $t^{-0,3}$ and temperature data in Table D.2. This requires that the times be plotted logarithmically against the reciprocal of the absolute temperature ($^{\circ}\text{C} + 273$) as shown in Figure D.2. If the Arrhenius relationship is followed, the result will be a linear graph.

An approximate best-fitting straight line is manually drawn through the points in the Arrhenius plot and extrapolation of the straight line is made to 24 °C. For the product used in this example, the yellow dye is predicted to lose 0,3 density units from an initial d_{\min} corrected density of 1,0 after 60 y when kept in the dark at 24 °C and 50 % RH.

In an analogous manner, an Arrhenius plot can also be made for any other density loss, such as 0,2 or 0,1.

D.3 Computerization of the Arrhenius method

When large numbers of photographic materials are subjected to this Arrhenius method for predicting the stabilities of colour photographs, the burden of handling the very large number of density values becomes a serious impediment to the usefulness of the method. Computerization is the remedy for this problem.

Generation of the values needed for the fading plot (Figure D.1) is readily handled by a computer, i.e. by calculation of the density decrease with time $[D_y(B)_t - D_y(B)_o]$. Programs are readily available for fitting such groups of data points.

After the computer calculates the optimum fit, the values of the time to lose any particular amount of density can then be determined by the computer. Programs are also available to fit the best straight line to the Arrhenius plot. These programs, however, are not the simple regression programs used in fitting straight lines to a series of points. In an Arrhenius plot, non-linear transformation of the raw data has occurred, i.e. taking the logarithm of the time to lose a given amount of density is a non-linear transformation. Therefore, considerably more complex curve-fitting methods (e.g. the non-linear least-squares method) are required.

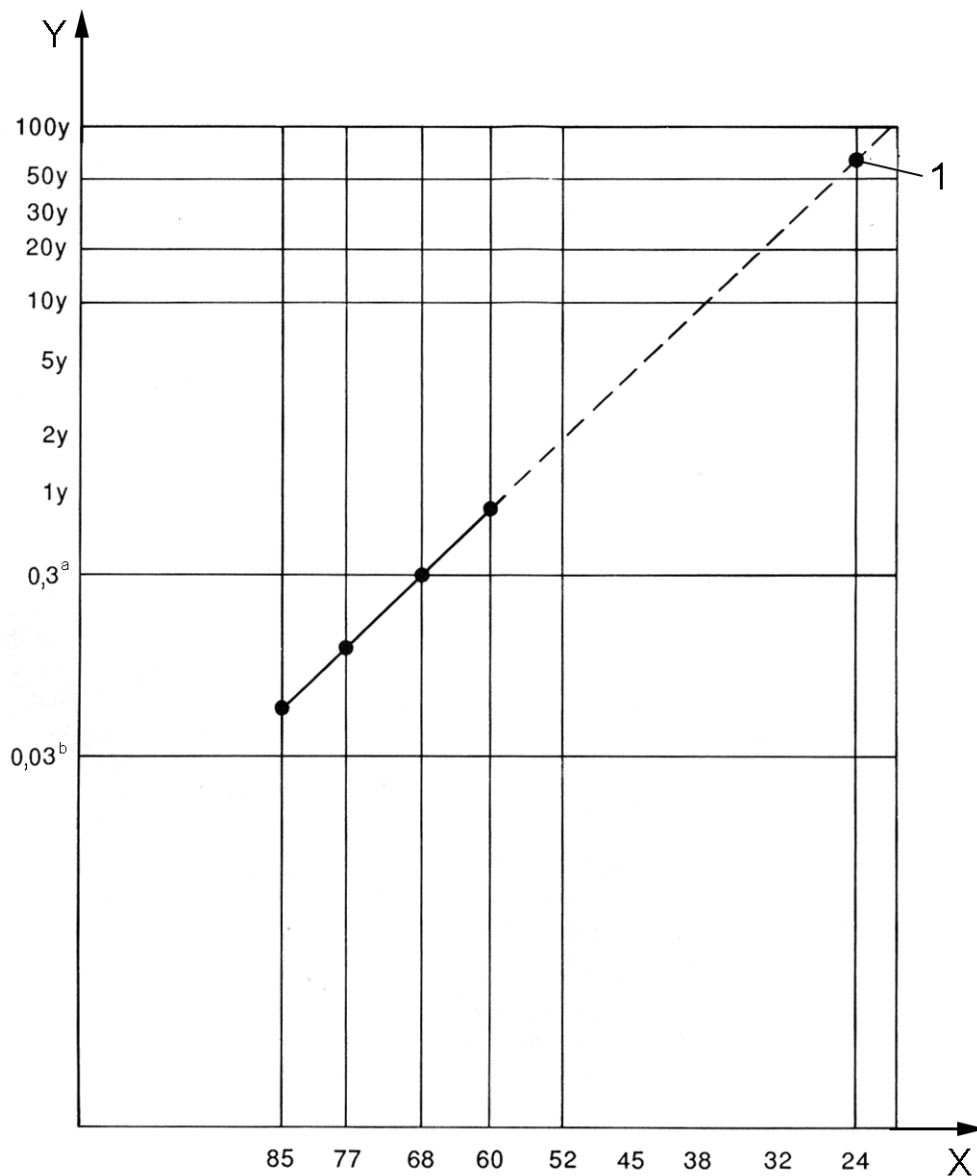

Key

- X temperature in °C
- Y time, in years, to lose 0,3 from initial density
- 1 60 y
- ^a = 100 d.
- ^b = 10 d.

NOTE Temperatures have been plotted as reciprocals of corresponding thermodynamic temperatures.

Figure D.2 — Arrhenius plot of blue density

Annex E (informative)

The importance of the starting density in the assessment of dye fading and colour balance changes in light-stability tests

To simplify preparation of test specimens and the handling of data, this International Standard specifies a starting density of 1,0 above d_{\min} for both light-stability and dark-stability tests, and requires that dye fading end-points be expressed as a percent density change.

As is shown in Table E.1, the starting density is of little significance in dark-stability tests – the chromogenic colour-negative print paper tested here shows practically the same percent density loss regardless of the starting density. It must be noted, however, that with typical chromogenic print materials in dark stability tests, the contribution of stain to measured density is proportionally greater in low densities than in high densities, and this generally causes colour balance changes to be greater in low-density areas of an image than in high densities.

In light fading, dye fading behaviour is very different. Unlike dark fading, the percent density losses measured in light fading are characteristically much larger in low densities than in high densities. In Table E.2, it can be seen that the percent density loss measured in a patch that had a starting density of 0,50 is twice that of a patch that had a starting density of 1,0; in a patch with a starting density of 0,30, the percent loss is more than three times that of a starting density of 1,0.

With many types of pictorial scenes, starting densities of 0,50 or 0,60 are visually the most critical in assessing changes caused by light fading. In some images, very-low-density detailed highlight areas (such as the rendering of texture in a white fabric, the facial highlights of a portrait, or the pale colouration of a late afternoon sky), densities as low as 0,10 above d_{\min} can be very important. In light fading, these low-density dye images can fade completely while high-density portions of the images may show little, if any, visually perceptible change. In dark fading, highlight detail is not lost in a corresponding manner.

For these reasons, with many types of pictorial scene, light-faded images will appear visually more faded than dark-faded images when both have suffered the same relative amount of dye loss (e.g. 30 %) when measured in areas with a starting density of 1,0. The light-faded images will have lost a disproportionate amount of density and usually also exhibit greater colour balance changes in visually critical medium and low-density areas.

Test prints with portraits and other common pictorial subjects can be useful in assessing fading and colour balance changes at various starting densities. Based on observations made with such prints, the user of this International Standard may wish to adopt different density change and colour balance end-points for light-stability and dark-stability tests

**Table E.1 — Dark fading of cyan dye (red density) in neutral patches
from chromogenic colour-negative paper in an accelerated dark-stability test**

Starting density above d_{\min}	Density change at end of test	Percent density change
0,30	– 0,14	– 47 %
0,40	– 0,19	– 48 %
0,50	– 0,24	– 48 %
0,60	– 0,28	– 47 %
1,00	– 0,46	– 46 %
1,50	– 0,72	– 48 %

Table E.2 — Light fading of magenta dye (green density) in neutral patches from chromogenic colour-negative paper in an accelerated light-stability test

Starting density above d_{\min}	Density change at end of test	Percent density change
0,30	– 0,14	– 47 %
0,40	– 0,15	– 38 %
0,50	– 0,15	– 30 %
0,60	– 0,15	– 25 %
1,00	– 0,15	– 15 %
1,50	– 0,14	– 9 %

Annex F (informative)

Enclosure effects in light-stability tests with prints framed under glass or plastic sheets

Studies with a variety of chromogenic print materials have shown that when certain of these materials are displayed for long periods under typical indoor illumination levels, framing or enclosing these prints with glass or plastic sheets can have a significant effect on fading and stain formation. The manner of processing (e.g. a water wash, use of a low-pH stabilizer, etc.) can have a pronounced influence on the rate of dye fading of these framed and displayed print materials.

Most commonly the enclosure effect in chromogenic prints is manifested by an increase in yellow dye fading in particular and, unlike what is generally observed with light fading, is most noticeable in high- and maximum-density areas of an image. The disproportionate loss of yellow dye eventually causes the image to suffer a pronounced blue shift in colour balance. The enclosure effect has been observed both in prints framed directly against glass and in prints that are separated from the framing glass by a cardboard overmat.

Experience has shown that the enclosure effect generally is subject to large reciprocity failures in high-intensity light stability tests; therefore, to meaningfully evaluate this phenomenon, long-term tests with illumination intensities of 1,0 klx or lower should be employed. Although the enclosure effect has been studied principally in chromogenic prints, other types of materials may be similarly affected.

A test frame that can be used to evaluate the enclosure effect is illustrated in Figure F.1. To prepare a test frame, glass and mount board backing sheet¹⁰⁾ are cut to the same size, approximately 50 mm longer in both dimensions than the test area of the print sample. The glass should be carefully cleaned with a mild, neutral-pH detergent, rinsed thoroughly with warm water, and dried with clean paper towels. Backing boards and overmats shall be made of white 4-ply 100 % cotton fibre non-buffered photographic mount board with an approximately neutral pH.

A stable and non reactive pressure-sensitive tape¹¹⁾ shall be used to attach the backing board, print, and overmat to the cover glass. The tape shall completely cover the edges of the test unit, with no vacant areas present through which air could circulate.

Print samples shall be prepared to the same size as the cover glass and backing board, with the test area at least 5 cm shorter in both dimensions than the print sample.

Print samples shall be tested in direct contact with the frame cover glass; if desired, identical samples shall also be tested in units with an overmat to maintain a separation between the print and the glass. Print-mounting adhesives shall not be used. The test frame shall not be opened except for short periods when density measurements are made.

10) A suitable material for backing sheets and overmats is Rising Photomount 4-ply white mount board manufactured by Rising Paper Company, Housatonic, MA 02136, USA. This information is given for the convenience of users of this International Standard and does not constitute an endorsement by ISO of the product named. Equivalent products may be used if they can be shown to lead to the same results.

11) A suitable tape is 3M Magic Transparent Tape No. 810, manufactured by the 3M Company, Commercial Tape Division, 3M Center, St. Paul, MN 55144, USA. This information is given for the convenience of users of this International Standard and does not constitute an endorsement by ISO of the product named. Equivalent products may be used if they can be shown to lead to the same results.

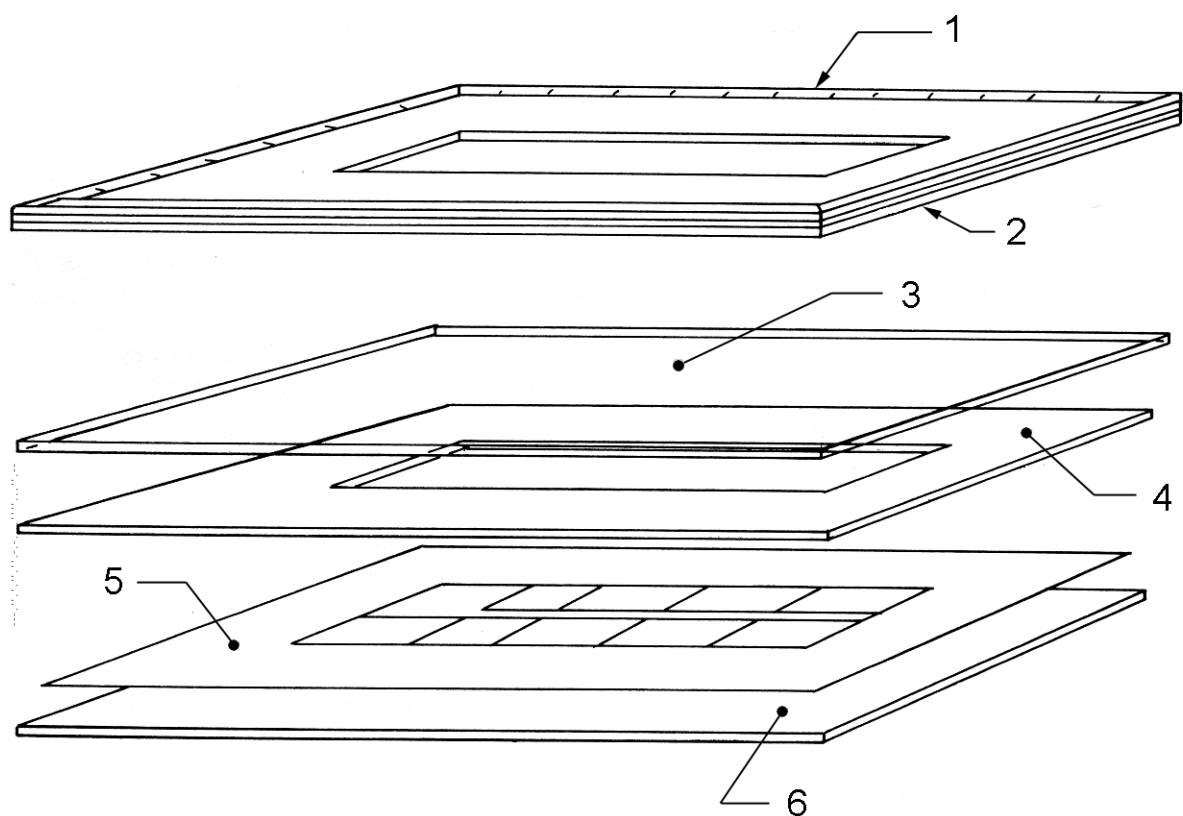

Key

- 1 assembled test frame
- 2 tape on edges
- 3 glass
- 4 overmat
- 5 colour test sample
- 6 backing board

Figure F.1 — Test frame

Annex G (informative)

Data treatment for the stability of light-exposed colour images

G.1 Introduction

This annex is a supplement to 6.3, light-stability tests, and is intended to demonstrate the procedure of manipulating density data for determining the stability of colour images exposed to light.

The example cited below corresponds to colour paper exposed to fluorescent illumination of 6,0 klx (see 5.7). Reflection-density data necessary for obtaining image-life parameters are measured after each period of light exposure. The stabilities derived from various parameters are expressed in the number of days required for the test specimen to reach the chosen end-points.

NOTE The end-points in each category have comparative meaning only. Development of a predictive method for long-term display under normal conditions awaits further investigation.

G.2 Data handling procedures

G.2.1 Density measurement

In this example, red, green and blue reflection-density measurements were made at d_{\min} , at 1,0 above d_{\min} for the neutral patch, and 1,0 above d_{\min} for the cyan, magenta, and yellow separation patches at 0 days (i.e. before illumination); 28 days; 56 days; 140 days; 224 days; and 308 days (see Table G.1).

Table G.1 — Reflection densitometry data

Time, t days	d_{\min}			Neutral patch			Colour patch		
	$d_{\min}(R)_t$	$d_{\min}(G)_t$	$d_{\min}(B)_t$	$d_N(R)_t$	$d_N(G)_t$	$d_N(B)_t$	$d_c(R)_t$	$d_m(G)_t$	$d_y(B)_t$
0	0,09	0,12	0,12	1,09	1,12	1,12	1,09	1,12	1,12
28	0,09	0,12	0,14	1,00	1,08	1,12	1,00	1,08	1,00
56	0,08	0,12	0,16	0,93	1,06	1,08	0,92	1,02	0,96
140	0,08	0,13	0,21	0,76	0,89	1,00	0,68	0,45	0,79
224	0,08	0,13	0,22	0,69	0,64	0,86	0,40	0,24	0,49
308	0,08	0,14	0,23	0,44	0,47	0,66	0,19	0,21	0,41

G.2.2 Graphical determination of stability parameters

From 3.7, calculate the d_{\min} corrected densities for the neutral patch and the colour patches, the neutral density patch colour balance, the d_{\min} changes, and the d_{\min} colour balance (see Table G.2).

Graph the data from Table G.2 (see Figures G.1 to G.5 which illustrate five of the necessary fifteen plots). From the graphs, determine the number of days to reach the chosen end-points for each of the stability parameters and identify which fails first.

Table G.2 — Density data calculations

Time, <i>t</i> days	Neutral patch (<i>d_{min}</i> corrected)				Colour patch (<i>d_{min}</i> corrected)			Neutral patch percentage colour balance (not <i>d_{min}</i> corrected)			<i>d_{min}</i> changes				<i>d_{min}</i> colour balance		
	$D_N(R)_t$	$D_N(G)_t$	$D_N(B)_t$	$D_N(B)_t$	$D_c(R)_t$	$D_M(G)_t$	$D_Y(B)_t$	$\% d_N(R - G)_t$	$\% d_N(R - B)_t$	$\% d_N(G - B)_t$	$d_{min}(R)_t - d_{min}(R)_0$	$d_{min}(G)_t - d_{min}(G)_0$	$d_{min}(B)_t - d_{min}(B)_0$	$d_{min}(R - G)_t$	$d_{min}(R - B)_t$	$d_{min}(G - B)_t$	
0	1,00	1,00	1,00	1,00	1,00	1,00	1,00	- 2,7	- 2,7	0	0,00	0,00	0,00	- 0,03	- 0,03	0,00	
28	0,91	0,96	0,99	0,91	0,96	0,87	- 7,6	- 11	- 3,6	0,00	0,00	+ 0,02	- 0,03	- 0,05	- 0,02		
56	0,84	0,94	0,94	0,83	0,90	0,82	- 13	- 15	- 1,8	- 0,01	0,00	+ 0,04	- 0,04	- 0,08	- 0,04		
140	0,67	0,77	0,84	0,59	0,33	0,63	- 16	- 27	- 12	- 0,01	+ 0,01	+ 0,09	- 0,05	- 0,13	- 0,08		
224	0,60	0,52	0,69	0,31	0,12	0,32	+ 8	- 22	- 29	- 0,01	+ 0,01	+ 0,10	- 0,05	- 0,14	- 0,09		
308	0,35	0,34	0,49	0,10	0,08	0,24	- 6,6	- 40	- 34	- 0,01	+ 0,02	+ 0,11	- 0,06	- 0,15	- 0,09		

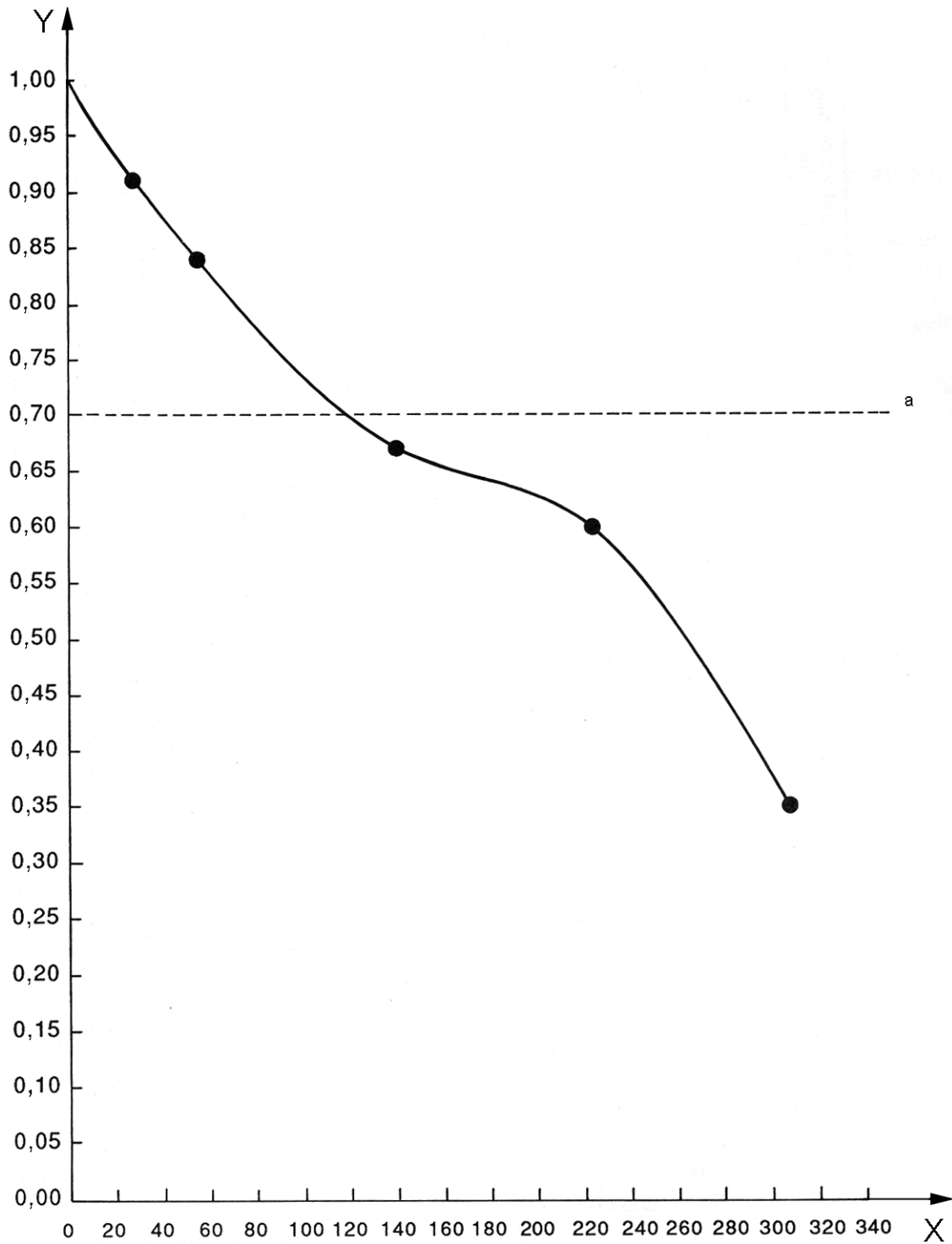

Key

- X time in days
- Y density $D_N(R)_t$
- a 30 % change.

Figure G.1 — Red density of neutral patch versus time, $D_N(R)_t$

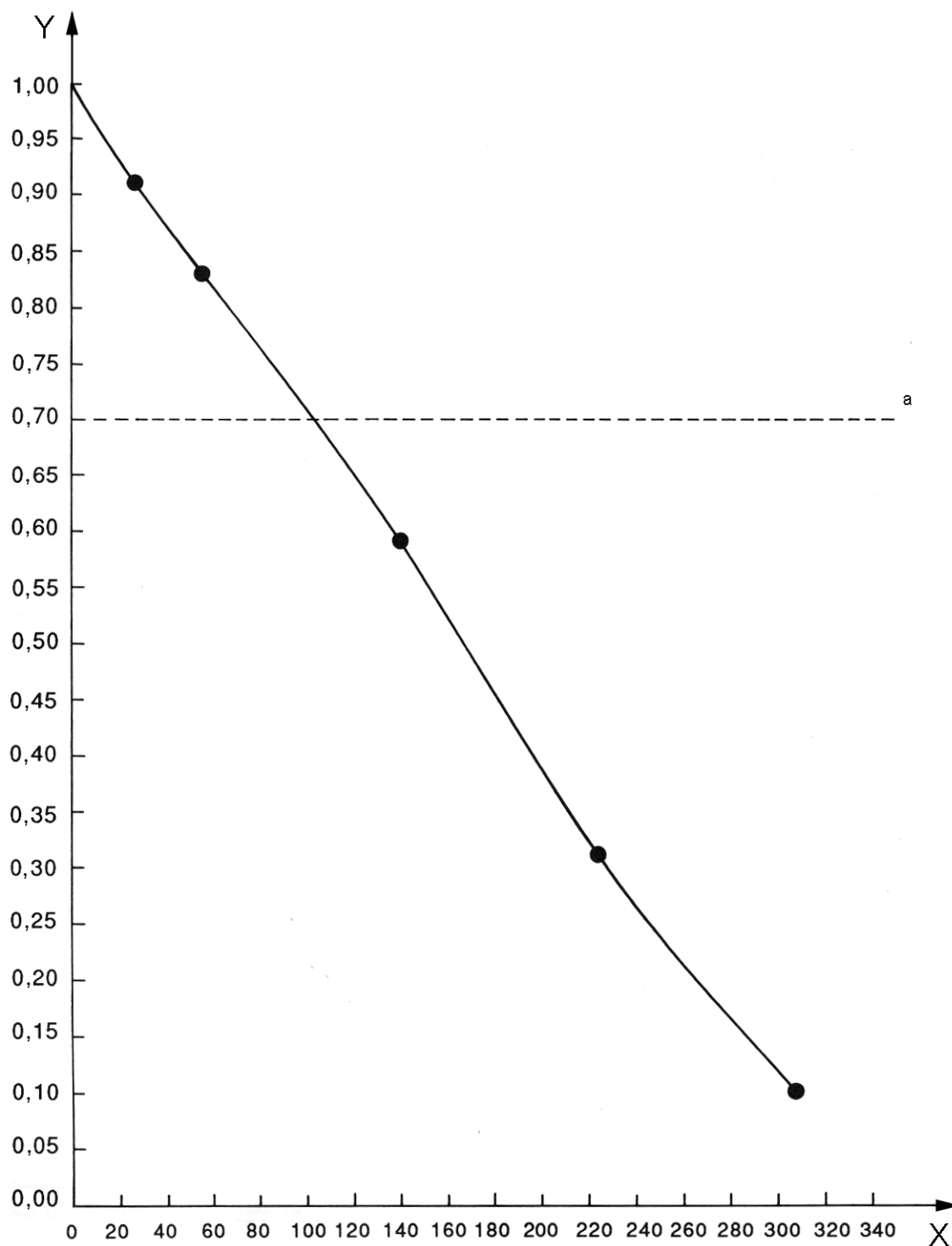

Key

- X time in days
- Y density $D_c(R)_t$
- a 30 % change.

Figure G.2 — Red density of cyan patch versus time, $D_c(R)_t$

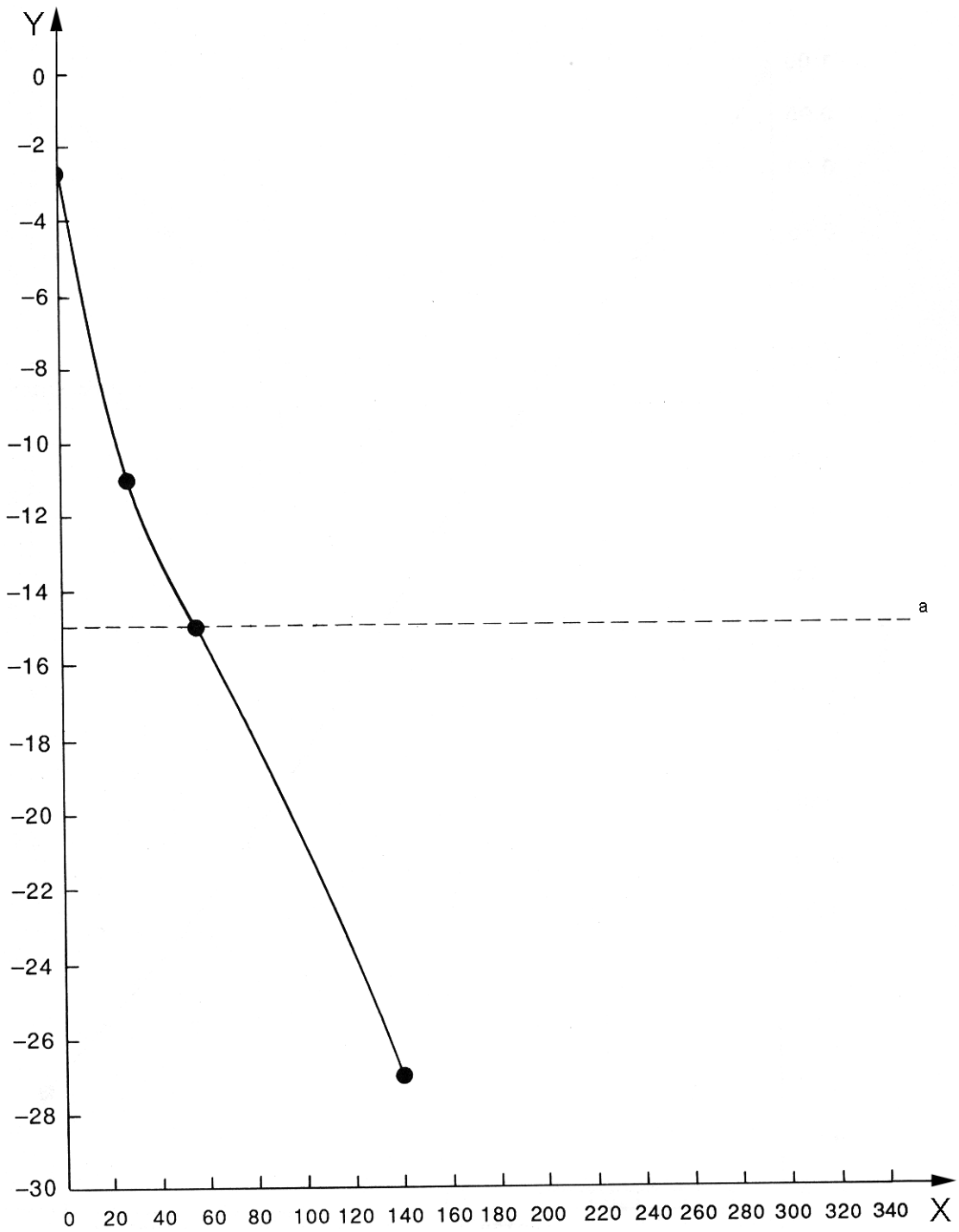

Key

- X time in days
- Y density $D_N(R - B)_t$
- a 15 % change.

Figure G.3 — Colour balance of neutral patch versus time (red minus blue hue), $D_N(R - B)_t$

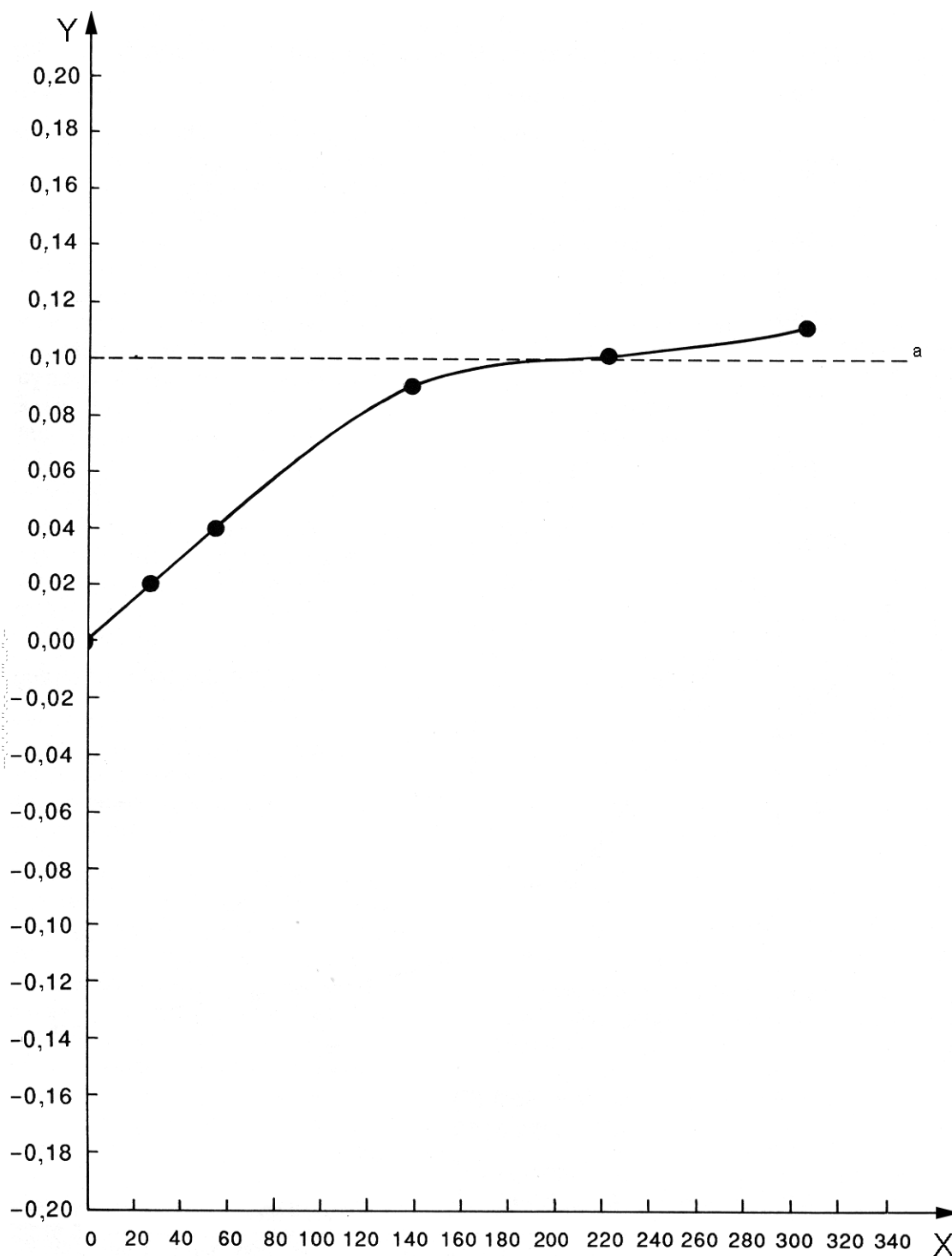

Key

X time in days

Y change in intensity $d_{\min}(B)_t - d_{\min}(B)_0$

a + 0,1 change.

Figure G.4 — Change in blue d_{\min} versus time, $d_{\min}(B)_t - d_{\min}(B)_0$

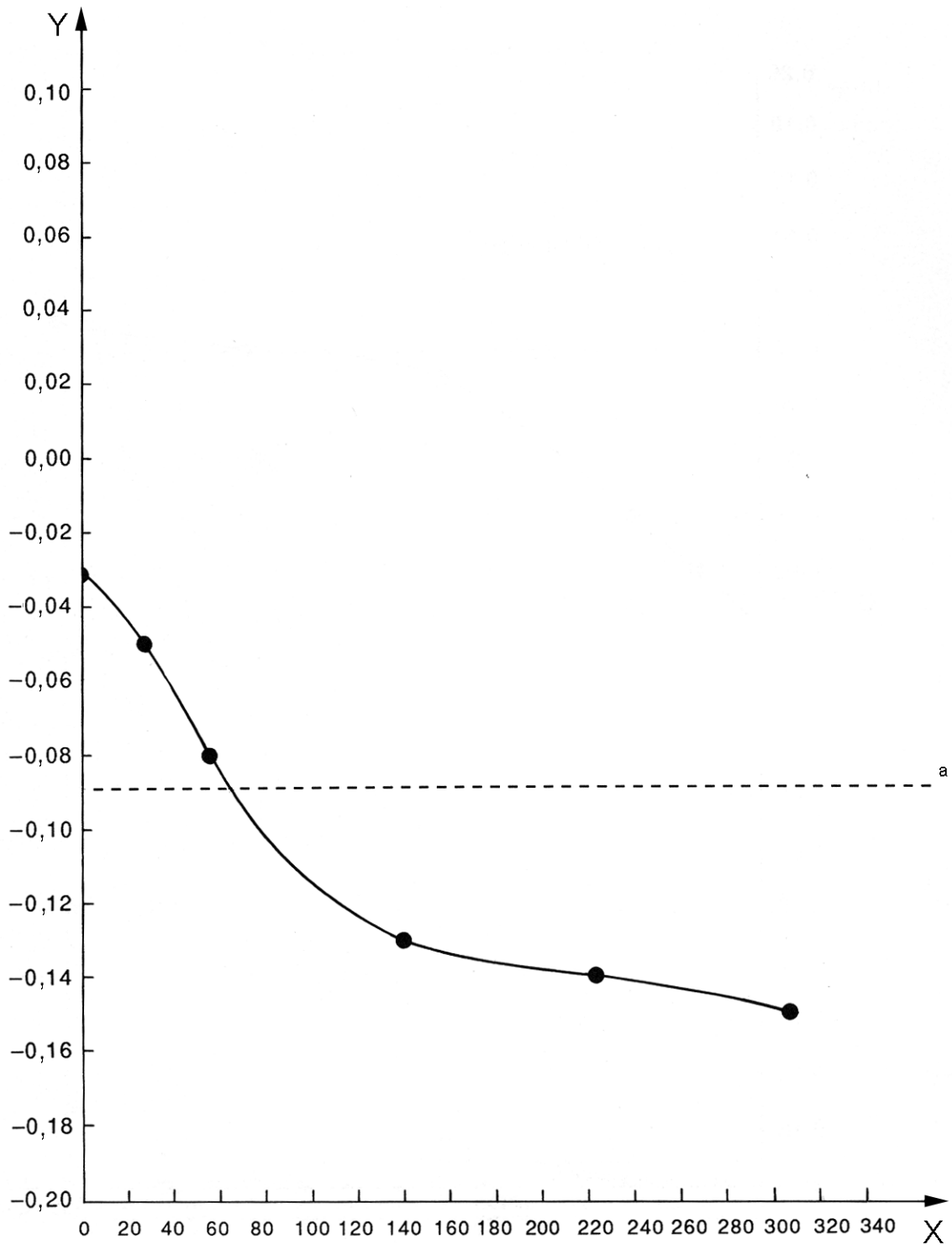

Key

X time in days

Y d_{\min} colour balance $d_{\min}(R - B)_t$

a $-0,06 d_{\min}$ colour balance change.

Figure G.5 — d_{\min} colour balance versus time, $d_{\min}(R - B)_t$

G.2.3 Results

Report the results according to 6.3. In this example, results are shown in Table G.3.

Table G.3 — Stability parameter results

Parameter	Days to reach the end-point
30 % change in 1,0 neutral patch	120 (red density)
30 % change in 1,0 colour patch	103 (red density)
15 % change in colour balance from 1,0 neutral	56 (red-blue)
0,10 change in d_{\min}	225 (blue density)
0,06 change in d_{\min} colour balance	40 (red-blue)

Bibliography

- [1] WILHELM, H. and BROWER, C. (contributing author), *The Permanence and Care of Color Photographs: Traditional and Digital Color Prints, Color Negatives, Slides, and Motion Pictures*, Preservation Publishing Company, Grinnell, IA, 1993, pp. 67–77
- [2] BARD, C.C., LARSON, G.W., HAMMOND, H.A. and PACKARD, C. Predicting Long-Term Dark Storage Dye Stability Characteristics of Color Photographic Products from Short-Term Tests, *Journal of Applied Photographic Engineering*, **6**(2), 1980, pp. 42–45
- [3] BARD, C.C. *Clearing the Air on the Stability of Color Print Papers, Program and Paper Summaries*, Fourth International Symposium on Photofinishing Technology, Society of Photographic Scientists and Engineers, Springfield, VA, 1986, p. 9
- [4] ARRHENIUS, S.A. *Zeitschrift für Physikalische Chemie*, **4**, 1889, p. 226
- [5] STEIGER, F.H. *The Arrhenius Equation in Accelerated Aging*, American Dyestuff Reporter, **47**(9), 1958, pp. 287–290
- [6] ADELSTEIN, P.Z. and MCCREA, J.L. Dark Image Stability of Diazo Films, *Journal of Applied Photographic Engineering*, **3**, 1977, pp. 173–178
- [7] MEYER, A. and BERMANE, D. Stability and Permanence of Cibachrome Images, *Journal of Applied Photographic Engineering*, **9**(4), 1983, pp. 121–125
- [8] HUNT, R.W.G. *The Reproduction of Colour* (4th edition), Fountain Press, Tolworth, GB, 1987, pp. 222–225
- [9] PINNEY, J.E. and VOGELSONG, W.F. Analytical Densitometry of Reflection Color Print Materials, *Photographic Science and Engineering*, **6**(6), 1962, pp. 367–370
- [10] RAM, A.T., KOPPERL, D.F., SEHLIN, R.C., MASARYK-MORRIS, S., VINCENT, J.L. and MILLER, P. The Effects and Prevention of the “Vinegar Syndrome,” *Journal of Imaging Science and Technology*, **38**(3), 1994, pp. 249–261
- [11] ANDERSON, S. and KOPPERL, D. Limitations of Accelerated Image Stability Testing, *Journal of Imaging Science and Technology*, **37**(4), 1993, pp. 363–373
- [12] MCCORMICK-GOODHART, M.H. Moisture-Content Isolines of Gelatin and the Implications for Accelerated Aging Tests and Long-Term Storage of Photographic Materials, *Journal of Imaging Science and Technology*, **39**(2), 1995, pp. 157–162
- [13] KRAUSE, P. *How Long Will Your Color Prints Last?—How Much Light is Hitting Your Prints?*, Popular Photography, April 1999, p. 76
- [14] TACHIKAWA, S. Fact-Finding Survey of Building Illumination, *Journal of the Illuminating Engineering Institute of Japan*, **59**, 1974, pp. 86–94
- [15] Eastman Kodak Company Publication E-140, KODAK PROFESSIONAL PORTRA III Paper, Print Judging and Viewing, Feb 16, 1999
- [16] TAKAHASHI, K. On Additivity of Reflection Density in Photographic Color Prints, *Journal of Imaging Science and Technology*, **36**(6), 1992, pp. 511–516
- [17] WILLIAMS, F.C. and CLAPPER, F.R. Multiple Internal Reflections in Photographic Color Prints, *Journal of the Optical Society of America*, **43**(7), 1953, pp. 595–599

- [18] OHTA, N. Reflection Density of Multilayer Color Prints I. Specular Reflection Density, *Photographic Science and Engineering*, **15**(6), 1962, pp. 487–494
- [19] ANDERSON, S. and LARSON, G. A Study of Environmental Conditions Associated with Customer Keeping of Photographic Prints, *Journal of Imaging Technology*, 1987, pp. 149-54
- [20] ANDERSON, S. and ANDERSON, R. A Study of Lighting Conditions Associated with Print Display in Homes, *Journal of Imaging Technology*, **17**, 1991, pp. 127-132
- [21] JIS Z8902, *Xenon standard white light source*
- [22] Clarke, F.J.J. Proceedings of the 19th Session of the CIE, Kyoto, p. 75
- [23] Clarke, F.J.J. Proceedings of the 19th Session of the CIE, Kyoto, p. 76
- [24] JIS Z 8719, *Metamerism index — Evaluation method of degree of metamerism for change in illuminant*
- [25] CIE 15.2, *CIE Recommendations on Colorimetry* (2nd edn., pp. 47-49)

© ISO 2006. All rights reserved.

ICS 37.040.20

Price based on 50 pages