

---

---

**Plastics — Determination of aerobic biodegradation of non-floating plastic materials in a seawater/sandy sediment interface — Method by measuring the oxygen demand in closed respirometer**

*Plastiques — Détermination de la biodégradation aérobie des matières plastiques immergées à l'interface eau de mer/sédiments sableux — Méthode par mesurage de la demande en oxygène dans un respiromètre fermé*



**COPYRIGHT PROTECTED DOCUMENT**

© ISO 2016, Published in Switzerland

All rights reserved. Unless otherwise specified, no part of this publication may be reproduced or utilized otherwise in any form or by any means, electronic or mechanical, including photocopying, or posting on the internet or an intranet, without prior written permission. Permission can be requested from either ISO at the address below or ISO's member body in the country of the requester.

ISO copyright office  
Ch. de Blandonnet 8 • CP 401  
CH-1214 Vernier, Geneva, Switzerland  
Tel. +41 22 749 01 11  
Fax +41 22 749 09 47  
copyright@iso.org  
www.iso.org

# Contents

Page

<b>Foreword</b> .....	<b>iv</b>
<b>Introduction</b> .....	<b>v</b>
<b>1 Scope</b> .....	<b>1</b>
<b>2 Normative references</b> .....	<b>1</b>
<b>3 Terms and definitions</b> .....	<b>1</b>
<b>4 Principle</b> .....	<b>2</b>
<b>5 Test environment</b> .....	<b>2</b>
<b>6 Reagents</b> .....	<b>2</b>
<b>7 Apparatus</b> .....	<b>3</b>
<b>8 Procedure</b> .....	<b>4</b>
8.1 Test material.....	4
8.2 Reference material.....	4
8.3 Preparation of the sediment.....	4
8.4 Test setup.....	4
8.5 Pre-conditioning phase.....	5
8.6 Start of the test.....	5
8.7 End of the test.....	5
<b>9 Calculation and expression of results</b> .....	<b>6</b>
9.1 Calculation.....	6
9.2 Visual inspection.....	6
9.3 Expression and interpretation of results.....	6
<b>10 Validity of results</b> .....	<b>7</b>
<b>11 Test report</b> .....	<b>7</b>
<b>Annex A (informative) Example of respirometric system based on pressure measurement</b> .....	<b>8</b>
<b>Bibliography</b> .....	<b>9</b>

## Foreword

ISO (the International Organization for Standardization) is a worldwide federation of national standards bodies (ISO member bodies). The work of preparing International Standards is normally carried out through ISO technical committees. Each member body interested in a subject for which a technical committee has been established has the right to be represented on that committee. International organizations, governmental and non-governmental, in liaison with ISO, also take part in the work. ISO collaborates closely with the International Electrotechnical Commission (IEC) on all matters of electrotechnical standardization.

The procedures used to develop this document and those intended for its further maintenance are described in the ISO/IEC Directives, Part 1. In particular the different approval criteria needed for the different types of ISO documents should be noted. This document was drafted in accordance with the editorial rules of the ISO/IEC Directives, Part 2 (see [www.iso.org/directives](http://www.iso.org/directives)).

Attention is drawn to the possibility that some of the elements of this document may be the subject of patent rights. ISO shall not be held responsible for identifying any or all such patent rights. Details of any patent rights identified during the development of the document will be in the Introduction and/or on the ISO list of patent declarations received (see [www.iso.org/patents](http://www.iso.org/patents)).

Any trade name used in this document is information given for the convenience of users and does not constitute an endorsement.

For an explanation on the meaning of ISO specific terms and expressions related to conformity assessment, as well as information about ISO's adherence to the World Trade Organization (WTO) principles in the Technical Barriers to Trade (TBT) see the following URL: [www.iso.org/iso/foreword.html](http://www.iso.org/iso/foreword.html).

The committee responsible for this document is ISO/TC 61, *Plastics*, Subcommittee SC 5, *Physical-chemical properties*.

## Introduction

Products made with biodegradable plastics are designed to be recovered by means of organic recycling in composting plants or in anaerobic digesters. The uncontrolled dispersion of biodegradable plastics in natural environments is not desirable. The biodegradability of products cannot be considered as an excuse to spread wastes that should be recovered and recycled. However, test methods to measure rate and level of biodegradation in natural environments (such as soil or the marine environment) are of interest in order to better characterize the behaviour of plastics in these very particular environments. As a matter of fact, some plastics are used in products that are applied in the sea (e.g. fishing gear) and sometimes they can get lost or put willingly in marine environment. The characterization of biodegradable plastic materials can be enlarged by applying specific test methods that enable the quantitative assessment of biodegradation of plastics exposed to marine sediment and seawater.

Plastic products are directly littered or arrive with fresh waters in the pelagic zone (free water). From there, and depending on density, tides, currents, and marine foiling may sink to the sublittoral, and reach the seafloor surface. Many biodegradable plastics have a density higher than 1 and therefore tend to sink. The sediment passes from aerobic to anoxic and finally anaerobic conditions going from the surface (the interface with seawater) into deeper layers, displaying a very steep oxygen gradient.



# Plastics — Determination of aerobic biodegradation of non-floating plastic materials in a seawater/sandy sediment interface — Method by measuring the oxygen demand in closed respirometer

## 1 Scope

This International Standard specifies a test method to determine the degree and rate of aerobic biodegradation of plastic materials when settled on marine sandy sediment at the interface between seawater and the seafloor, by measuring the oxygen demand in a closed respirometer.

Measurement of aerobic biodegradation can also be obtained by monitoring the carbon dioxide evolution. This is not in the scope of this International Standard but of ISO 19679.

This test method is a simulation under laboratory conditions of the habitat found in different seawater/sediment-areas in the sea, e.g. in a benthic zone where sunlight reaches the ocean floor (photic zone) that, in marine science, is called sublittoral zone

The determination of biodegradation of plastic materials buried in marine sediment is outside the scope of this International Standard.

The conditions described in this International Standard may not always correspond to the optimum conditions for the maximum degree of biodegradation to occur.

## 2 Normative references

The following documents, in whole or in part, are normatively referenced in this document and are indispensable for its application. For dated references, only the edition cited applies. For undated references, the latest edition of the referenced document (including any amendments) applies.

ISO 14851:1999, *Determination of the ultimate aerobic biodegradability of plastic materials in an aqueous medium — Method by measuring the oxygen demand in a closed respirometer*

ISO 8245, *Water quality — Guidelines for the determination of total organic carbon (TOC) and dissolved organic carbon (DOC)*

## 3 Terms and definitions

For the purposes of this document, the following terms and definitions apply.

### 3.1

#### **biochemical oxygen demand**

#### **BOD**

mass concentration of the dissolved oxygen consumed under specified conditions by the aerobic biological oxidation of a chemical compound or organic matter in water

Note 1 to entry: It is expressed as milligrams of oxygen uptake per milligram or gram of test compound.

### 3.2

#### **theoretical oxygen demand**

##### **ThOD**

theoretical maximum amount of oxygen required to oxidize a chemical compound completely, calculated from the molecular formula

Note 1 to entry: It is expressed as milligrams of oxygen uptake per milligram or gram of test compound.

### 3.3

#### **total organic carbon**

##### **TOC**

all the carbon present in organic matter which is dissolved or suspended in water

### 3.4

#### **pre-conditioning phase**

pre-incubation of an inoculum under the conditions of the subsequent test in the absence of test material, with the aim to consume potential organic matter present in excess that could disturb biodegradation measurement and to improve the acclimatization of the microorganisms to the test conditions

## 4 Principle

This test method is based on the determination of biological oxygen demand (BOD) and derives from ISO 14851. The testing medium is based on a solid phase and a liquid phase. The solid phase is sandy marine sediment laid in the bottom of a closed flask; the liquid phase is a column of natural or artificial sea water, poured on the sediment. The test material is preferably in the form of a film to be laid down on top of the sediment, at the interface between the solid phase and the liquid phase. This is a simulation of an object that has sunk and finally reached the sea floor. The system is contained in a closed flask, in a respirometer. The carbon dioxide evolved is absorbed in a suitable absorber in the headspace of the flasks. The consumption of oxygen (BOD) is determined, for example, by measuring the amount of oxygen required to maintain a constant volume of gas in the respirometer flasks, or by measuring the change in volume or pressure (or a combination of the two) either automatically or manually.

The level of biodegradation is determined by comparing the BOD with the theoretical amount (ThOD) and expressed in percentage. The influence of possible nitrification processes on the BOD shall be considered. The test result is the maximum level of biodegradation determined from the plateau phase of the biodegradation curve.

The details of interlaboratory testing based on the test method specified in this International Standard are available in Reference [4].

## 5 Test environment

Incubation shall take place in the dark or diffused light in an enclosure which is free from vapours inhibitory to microorganisms and which is maintained at a constant temperature, preferably between 15 °C to 25 °C, but not exceeding 28 °C, to an accuracy of  $\pm 2$  °C. Any change in temperature shall be justified and clearly indicated in the test report.

NOTE Test results are obtained for temperature that may be different from real conditions in marine environment.

## 6 Reagents

**6.1 Distilled or deionized water**, free of toxic substances (copper in particular) and containing less than 2 mg/l of DOC.



## 6.2 Artificial seawater

Dissolve:

Sodium chloride (NaCl)	22 g
Magnesium chloride hexahydrate ( $\text{MgCl}_2 \cdot 6 \text{H}_2\text{O}$ )	9,7 g
Sodium sulfate ( $\text{Na}_2\text{SO}_4$ )	3,7 g
Calcium chloride ( $\text{CaCl}_2$ )	1 g
Potassium chloride (KCl)	0,65 g
Sodium hydrogen carbonate ( $\text{NaHCO}_3$ )	0,20 g

in water (6.1) and make up to 1 000 ml.

## 6.3 Natural seawater/sediment

Take a sample of a sandy sediment and seawater with a shovel beneath the low-water line into a bucket. Transfer the wet sediment together with seawater into sealed containers for transport and fast deliver it to the laboratory. After delivery, conserve the sediment at low temperature (approximately 4 °C) until use. The seawater/sediment sample should be preferably used within 4 weeks after sampling. Record storage time and conditions.

NOTE Seawater and sediment can also be sampled from large, well-running public marine aquaria.

Measure the TOC, pH and nitrogen content of the sediment and of the natural seawater if used instead of artificial seawater. The carbon content of sediment should be in the range of 0,1 % to 2 %.

A preliminary oxidation can be applied to the sediment in order to decrease the organic matter content and the background respiration. Sediment and seawater are fluxed with air and gently stirred (max. 20 r/min to 30 r/min) in a large container for the desired period of time. Report this pre-treatment procedure in the test report.

## 7 Apparatus

**7.1 Closed respirometer**, including test vessels (glass flasks) and all other necessary equipment, shall be located in a constant-temperature room or in a thermostat apparatus (e.g. water-bath). For an example, see [Annex A](#) or ISO 14851:1999, Annex C. Stirring can be applied on seawater on condition that it does not disturb the sediment/seawater interface. An example of a stirred apparatus is given in OECD TG 308, Annex 4.[\[3\]](#)

NOTE Any respirometer able to determine with sufficient accuracy the biochemical oxygen demand is suitable, preferably an apparatus which measures and replaces automatically and continuously the oxygen consumed so that no oxygen deficiency and no inhibition of the microbial activity occurs during the degradation process. Analytical equipment to measure total organic carbon (TOC) and dissolved organic carbon (DOC) is given in ISO 8245.

### 7.2 Analytical equipment for measuring nitrate and nitrite concentrations

A qualitative test is recommended first to decide if any nitrification has occurred. If there is evidence of nitrate/nitrite in the medium, a quantitative determination using a suitable method (for example ion chromatography) is required.

### 7.3 Analytical balance (usual laboratory equipment)

Analytical balance shall have a sensitivity of at least 0,1 mg.

## 7.4 pH meter (usual laboratory equipment)

# 8 Procedure

## 8.1 Test material

The test material should be in film or sheet form. Cut samples of the test material in the shape of a disk. Disks shall have a smaller diameter than the glass flasks, so that the disks can be easily laid on the bottom of the glass flask.

The sample shall be of known mass and contain sufficient carbon to yield a BOD that can be adequately measured by the respirometer used.

Use a test material concentration of at least 100 mg/l of seawater plus sediment. The mass of the samples should correspond to a ThOD of about 170 mg/l or a TOC of about 60 mg/l. The maximum mass of sample per flask is limited by the oxygen supply to the respirometer.

Calculate the ThOD (see ISO 14851:1999, Annex A) and the TOC (using ISO 8245 or from the chemical formula or determine by elemental analysis).

The form and shape of the test material may influence its biodegradability. Similar shapes and thicknesses should preferably be used if different kinds of plastic materials are to be compared.

NOTE 1 The test material may also be introduced as powder. However, this can be critical, as practical experience has shown that it is difficult to keep a powder settled at the sediment/seawater interface without special measures. Refer to ISO 10210 for preparation of powder from plastic materials.

NOTE 2 The test material in form of film laid down on the surface of the sediment could limit the gas exchange between the water body and the sediment, promoting the formation of an anaerobic zone under the test material. In order to reduce this effect, it is possible to perforate the film sample homogeneously over the entire surface.

## 8.2 Reference material

Use ashless cellulose filters as a reference material<sup>1)</sup>.

If possible, the TOC, form and size should be comparable to that of the test material. As a negative control, a non-biodegradable polymer (e.g. polyethylene) in the same form as the test material can optionally be used.

## 8.3 Preparation of the sediment

Filter the sediment in a funnel with a coarse filter paper to eliminate excess seawater. Sediment is ready for testing when dripping of sea water is ended. Sediment after filtering is named "wet sediment" hereafter.

## 8.4 Test setup

Provide several flasks, so that the test includes at least the following:

- a) three flasks for the test material (symbol  $F_T$ );
- b) three flasks for the blank (symbol  $F_B$ );
- c) three flasks for reference material (symbol  $F_C$ ).

---

1) Laboratory filter paper Whatman n° 42 has been found satisfactory for this purpose and is an example of a suitable product available commercially. This information is given for the convenience of users of this document and does not constitute an endorsement by ISO of this product.

In addition, it is possible to add three more flasks for negative control (symbol  $F_N$ ), if required.

NOTE Two flasks for test material, blank, and reference material may be used instead of three for screening purposes.

## 8.5 Pre-conditioning phase

In a typical case, use a test flask with a volume of 250 ml. Lay down 30 g of the wet sediment on the bottom of the flask. Carefully pour 70 ml of natural or artificial seawater. The test should be performed with a water/sediment volume ratio between 3:1 and 5:1 and a sediment layer of about 0,3 cm to 0,5 cm, depending on the granulometry of the sediment.

NOTE When using very coarse-grained sediment, the layer may be increased up to 1,5 cm.

Add a carbon dioxide absorber to the absorber compartments of the respirometer (see ISO 14851:1999, Annex C). Place the flasks in a constant-temperature environment and allow all vessels to reach the desired temperature. Take the necessary readings on the manometers (if manual) and verify that the recorder of oxygen consumption is functioning properly (automatic respirometer).

This phase is carried out in order to verify that the endogenous respiration is similar in the different vessels and also to obtain a preliminary oxidation of excess organic matter, in order to start the test with a lower endogenous respiration. The inoculum can be gently stirred in order to accelerate the biodegradation of the organic matter.

This phase is generally protracted for a week but it is possible to extend this period if high oxygen consumption is recorded.

In case the oxygen consumption of a vessel is different, reject the diverging vessel, or in case of multiple anomalies, start again using new sediment.

## 8.6 Start of the test

Dunk the plastic film sample, cut as described in [8.1](#), on the sediment of each vessel. Mass of samples (test and reference material) should be about 20 mg each when using a flask with a volume of 250 ml. In order to ensure a homogeneous contact between sample and sediment, it is recommended to cover the sample with a suitable cover slip. The cover slips shall be introduced in blank vessels also, for assuring similar conditions.

NOTE A suitable cover slip can be made using a common non-biodegradable vinyl-coated fibreglass mosquito net with a fibre diameter of about 280  $\mu\text{m}$  and a 1,8 mm  $\times$  1,6 mm mesh.

Repeat the procedure for the reference material and the material for the negative control to the respective flasks. Record the mass of the sediment, the sample and the volume of seawater introduced in each vessel.

Nutrients may be supplemented as needed to support microbial diversity and to maintain the capacity to biodegrade the test material. The need and timing of additional nutrients or other appropriate measures may be judged by observation of the temporal course of the biodegradation of the reference substance cellulose. Any addition and the applied method shall be reported in the test report.

## 8.7 End of the test

When a constant level of BOD is attained (plateau phase reached) and no further biodegradation is expected, the test is considered to be completed. The maximum test period is 24 months. In the case of long test durations, special attention shall be paid to the technical system (e.g. tightness of the test vessels and connections). Any special measures taken, for example, to ensure microbial diversity or to provide sufficient nutrients shall be detailed in the test report.

At the end of the test, determine the concentrations of nitrate and nitrite immediately in the flasks, or take suitably preserved samples. Use the values to correct the calculated degree of biodegradation for nitrification (see ISO 14851:1999, Annex B).

## 9 Calculation and expression of results

### 9.1 Calculation

Read the oxygen consumption values for each flask, using the method given by the manufacturer for the appropriate type of respirometer. Calculate the specific biochemical oxygen demand ( $BOD_S$ ) of the test material as the difference between oxygen consumption in the test flasks  $F_T$  and the blanks  $F_B$  divided by the concentration of the test material, using [Formula \(1\)](#):

$$BOD_S = \frac{BOD_t - BOD_{Bt}}{\rho_{TC}} \quad (1)$$

where

$BOD_S$  is the specific BOD, in mg per milligram of test material;

$BOD_t$  is the BOD of the flasks  $F_T$  containing test material at time  $t$ , in mg/l;

$BOD_{Bt}$  is the BOD of the blank  $F_B$  at time  $t$ , in mg/l;

$\rho_{TC}$  is the concentration of the test material in the reaction mixture of flask  $F_T$ , in mg/l.

Calculate the percentage biodegradation,  $D_t$ , as the ratio of the specific biochemical oxygen demand to the theoretical oxygen demand (ThOD, in mg per gram of test material), using [Formula \(2\)](#):

$$D_t = \frac{BOD_S}{ThOD} \times 100 \quad (2)$$

Calculate, in the same way, the BOD and percentage biodegradation of the reference material  $F_C$  and, if included, the negative control  $F_N$ .

**NOTE** For calculation of the ThOD, see ISO 14851:1999, Annex A. If significant concentrations of nitrite and nitrate are determined, consider the oxygen demand due to nitrification (see ISO 14851:1999, Annex B).

### 9.2 Visual inspection

At the end of the test, check the conditions of samples. If still present, samples can be retrieved for mass determination, and other analysis, and photographs.

### 9.3 Expression and interpretation of results

Compile a table of the BOD values measured and the percentages of biodegradation for each measurement interval and each test flask. For each vessel, plot a BOD curve and a biodegradation curve in percentage as a function of time.

A curve of averages may be plotted.

The maximum level of biodegradation determined as the mean value of the plateau phase of the biodegradation curve or the highest value, e.g. when the curve decreases or, further on, slowly increases in the plateau phase, characterizes the degree of biodegradation of the test material.

The wettability and the shape of the test material may influence the result obtained, and hence, the test procedure may be limited to comparing plastic materials of similar chemical structure.

Information on the toxicity of the test material may be useful in the interpretation of test results showing a low biodegradability.

## 10 Validity of results

The test is considered valid, if

- a) the degree of biodegradation of the reference material ( $F_C$ ) is >60 % after 180 days,
- b) the BOD of the blank  $F_B$  at the end of the test does not exceed an upper limiting value,

NOTE This value depends on the amount of inoculum; in a typical case, reported in [8.5](#), the value is 300 mg/l after 6 months, as shown in the interlaboratory test [\[4\]](#).

- c) the BOD values of the three blanks  $F_B$  are within 20 % of the mean at the plateau phase or at the end of the test,
- d) the difference between the percentage biodegradation of the reference material in the different vessels is less than 20 % of the mean at the end of the test.

If flask  $F_N$  (negative control) was included, no significant amount of BOD shall be observed.

If these criteria are not fulfilled, repeat the test using another sediment.

## 11 Test report

The test report shall contain the following information:

- a) a reference to this International Standard, i.e. ISO 18830:2016;
- b) all information necessary to identify the test and reference materials, including their TOC, ThOD, chemical composition and formula (if known), shape, form and amount in the samples tested;
- c) the main test parameters, including test volume, test medium used, incubation temperature and final pH;
- d) the source and amount of the marine sediment used;
- e) the analytical techniques used, including the principle of the respirometer and the TOC and nitrate/nitrite determinations;
- f) all the test results obtained for the test and reference materials (in tabular and graphical form), including the measured BOD, the percentage biodegradation values, the respective curves of these parameters against time and the nitrate/nitrite concentrations;
- g) the duration of the lag phase, biodegradation phase and maximum level of degradation, as well as the total test duration, and, optionally, if run or determined, the negative control  $F_N$ ;
- h) any other relevant data (e.g. result of the visual final inspection and analysis of final samples, if still retrievable; photos of the final samples);
- i) details of the methods used during the test period in order to support microbial diversity or to avoid nutrient deficiency (if used);
- j) any deviations from the test conditions described in this International Standard.

## Annex A (informative)

### Example of respirometric system based on pressure measurement

Biological oxygen demand (BOD) respirometers can be based on a pressure measurement in a closed system. Microorganisms in the vessel consume  $O_2$  and form  $CO_2$ . This is absorbed by a  $CO_2$  absorber (generally NaOH), creating a vacuum which can be read directly as a measured value in mg/l BOD.

In a typical case, a 250 ml vessel is used. The sediment occupies about 20 ml, the seawater 70 ml and the headspace 160 ml. The  $O_2$  present in air at 1 atm and 28 °C and a relative humidity of 100 % is about 0,261 mg/ml. This means that the  $O_2$  available at the beginning is  $0,261 \text{ mg/ml} \times 160 \text{ ml} = 41,76 \text{ mg}$  (1,305 mM). The amount dissolved in the seawater can be neglected. This amount of  $O_2$  is sufficient to oxidize to  $CO_2$  and  $H_2O$  an amount of biodegradable organic carbon equal to 15,66 mg and producing  $1,305 \times 44 = 57,42 \text{ mg}$  of  $CO_2$ .

The system needs to be opened in order to refresh the headspace when the  $O_2$  concentration reaches 25 % of the original oxygen concentration.

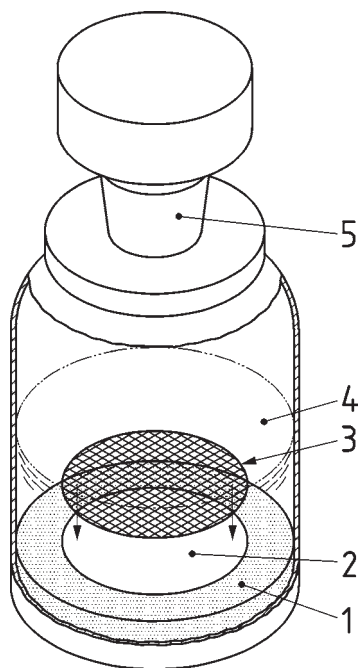

#### Key

- 1 sediment
- 2 sample
- 3 cover slip
- 4 liquid medium
- 5 monitoring system containing a  $CO_2$  absorbent

**Figure A.1 — BOD flask**

## Bibliography

- [1] ISO 10210, *Plastics — Methods for the preparation of samples for biodegradation testing of plastic materials*
- [2] TOSIN M., WEBER M., SIOTTO M., LOTT C., DEGLI-INNOCENTI F. Laboratory test methods to determine the degradation of plastics in marine environmental conditions. *Front. Microbiol.* 2012, **3** p. 225. DOI:10.3389/fmicb.2012.00225
- [3] OECD TG 308, *Guidelines for the Testing of Chemicals, Test No. 308: Aerobic and Anaerobic Transformation in Aquatic Sediment Systems*
- [4] ISO/TC61/SC5/WG22 doc. N 17, Ring test final report seawater sediment interface
- [5] ISO 19679, *Plastics — Determination of aerobic biodegradation of non-floating plastic materials in a seawater/sediment interface — Method by analysis of evolved carbon dioxide*

