**Plastics piping systems for non-pressure
drainage and sewerage — Polyester resin
concrete (PRC) —**

**Part 1:
Pipes and fittings with flexible joints**

*Systèmes de canalisations en plastique pour les branchements et les
collecteurs d'assainissement sans pression — Béton résines polyester
(BRP) —*

Partie 1: Tubes et raccords avec assemblages flexibles



Reference number
ISO 18672-1:2009(E)

PDF disclaimer

This PDF file may contain embedded typefaces. In accordance with Adobe's licensing policy, this file may be printed or viewed but shall not be edited unless the typefaces which are embedded are licensed to and installed on the computer performing the editing. In downloading this file, parties accept therein the responsibility of not infringing Adobe's licensing policy. The ISO Central Secretariat accepts no liability in this area.

Adobe is a trademark of Adobe Systems Incorporated.

Details of the software products used to create this PDF file can be found in the General Info relative to the file; the PDF-creation parameters were optimized for printing. Every care has been taken to ensure that the file is suitable for use by ISO member bodies. In the unlikely event that a problem relating to it is found, please inform the Central Secretariat at the address given below.



COPYRIGHT PROTECTED DOCUMENT

© ISO 2009

All rights reserved. Unless otherwise specified, no part of this publication may be reproduced or utilized in any form or by any means, electronic or mechanical, including photocopying and microfilm, without permission in writing from either ISO at the address below or ISO's member body in the country of the requester.

ISO copyright office
Case postale 56 • CH-1211 Geneva 20
Tel. + 41 22 749 01 11
Fax + 41 22 749 09 47
E-mail copyright@iso.org
Web www.iso.org

Published in Switzerland

Contents

Page

Foreword.....	iv
1 Scope	1
2 Normative references	1
3 Terms, definitions, symbols and abbreviations	2
3.1 Terms and definitions.....	2
3.2 Symbols and abbreviations	6
4 General requirements.....	9
4.1 Materials	9
4.2 Appearance	10
4.3 Reference conditions for testing.....	10
4.4 Joints.....	10
5 Pipes.....	11
5.1 Classification.....	11
5.2 Designation	12
5.3 Geometrical characteristics.....	12
5.4 Mechanical characteristics	20
5.5 Marking of pipes	24
6 Fittings	24
6.1 General.....	24
6.2 Bends	25
6.3 Branches.....	28
6.4 Marking of fittings.....	30
7 Joint performance.....	30
7.1 General.....	30
7.2 Requirements	30
Annex A (normative) Test method for the determination of a pipe's crushing strength and ring bending tensile strength using a pipe test piece	34
Annex B (normative) Test method for the determination of a pipe's crushing strength or ring bending tensile strength using test pieces sawn from a pipe	42
Annex C (normative) Test methods for the assessment of longitudinal bending moment resistance	48
Annex D (normative) Test method for the determination of the compressive strength of polyester resin concrete (PRC) using test pieces cut from a pipe	54
Annex E (normative) Test method for the determination of the fatigue strength of a pipe under cyclic loading	58
Annex F (normative) Method for the assessment of the leaktightness of a pipe and its joints under short-term exposure to internal water pressure.....	63
Annex G (normative) Test method for the determination of the long-term (50 years) crushing strength of a pipe, including the effects of media attack	65

Foreword

ISO (the International Organization for Standardization) is a worldwide federation of national standards bodies (ISO member bodies). The work of preparing International Standards is normally carried out through ISO technical committees. Each member body interested in a subject for which a technical committee has been established has the right to be represented on that committee. International organizations, governmental and non-governmental, in liaison with ISO, also take part in the work. ISO collaborates closely with the International Electrotechnical Commission (IEC) on all matters of electrotechnical standardization.

International Standards are drafted in accordance with the rules given in the ISO/IEC Directives, Part 2.

The main task of technical committees is to prepare International Standards. Draft International Standards adopted by the technical committees are circulated to the member bodies for voting. Publication as an International Standard requires approval by at least 75 % of the member bodies casting a vote.

Attention is drawn to the possibility that some of the elements of this document may be the subject of patent rights. ISO shall not be held responsible for identifying any or all such patent rights.

ISO 18672-1 was prepared by Technical Committee ISO/TC 138, *Plastics pipes, fittings and valves for the transport of fluids*, Subcommittee SC 6, *Reinforced plastics pipes and fittings for all applications*.

ISO 18672 consists of the following parts, under the general title *Plastics piping systems for non-pressure drainage and sewerage — Polyester resin concrete (PRC)*:

— *Part 1: Pipes and fittings with flexible joints*

Plastics piping systems for non-pressure drainage and sewerage — Polyester resin concrete (PRC) —

Part 1: Pipes and fittings with flexible joints

1 Scope

This part of ISO 18672 specifies definitions, requirements and characteristics of pipes, fittings, joints, materials, test methods and marking for pipes and fittings made from polyester resin concrete (PRC), intended to be used within a drain or sewer system operating without pressure. It applies to products for use in buried installations to be installed by open-trench techniques or pipe jacking.

It applies to pipes, fittings and their joints of nominal sizes from DN 150 to DN 3000 for circular cross-sections, from WN/HN 300/450 to WN/HN 1400/2100 for egg-shaped cross-sections and from DN 800 to DN 1800 for kite-shaped cross-sections.

The intended use of these products is for the conveyance of sewage, rainwater and surface water at temperatures up to 50 °C, without pressure or occasionally at a head of pressure up to 0,5 bar¹⁾, and installed in areas subjected to vehicle and/or pedestrian traffic.

The pipes are classified on the basis of the intended method of installation and cross-sectional shape.

NOTE It is the responsibility of the purchaser or specifier to make the appropriate selections, taking into account the particular requirements and any relevant national regulations and installation practices or codes.

2 Normative references

The following referenced documents are indispensable for the application of this document. For dated references, only the edition cited applies. For undated references, the latest edition of the referenced document (including any amendments) applies.

ISO 75-2, *Plastics — Determination of temperature of deflection under load — Part 2: Plastics and ebonite*

ISO 3126, *Plastics piping systems — Plastics components — Determination of dimensions*

ISO 7510, *Plastics piping systems — Glass-reinforced plastics (GRP) components — Determination of the amounts of constituents using the gravimetric method*

ISO 8639, *Glass-reinforced thermosetting plastics (GRP) pipes and fittings — Test methods for leaktightness of flexible joints*

ISO 10928, *Plastics piping systems — Glass-reinforced thermosetting plastics (GRP) pipes and fittings — Methods for regression analysis and their use*

EN 681-1, *Elastomeric seals — Material requirements for pipe joint seals used in water and drainage applications — Part 1: Vulcanized rubber*

1) 1 bar = 0,1 MPa = 0,1 N/mm² = 10⁵ N/m²

3 Terms, definitions, symbols and abbreviations

3.1 Terms and definitions

For the purposes of this document, the following terms and definitions apply.

3.1.1

adaptor

fitting that provides for connections to structures, pipes of other materials, or valves

3.1.2

angular deflection

δ

angle between the axes of two adjacent pipes

See Figures 1b) and 1c).

NOTE Angular deflection is expressed in degrees (°).

3.1.3

bend

fitting that provides for a change of alignment within a pipeline

3.1.4

branch

fitting comprising a pipe with one additional connecting pipe of equal or smaller nominal size, DN or WN/HN, to connect two pipelines

NOTE See 3.1.13 and 3.1.14 for DN and WN/HN.

3.1.5

design service temperature

maximum sustained temperature at which the system is expected to operate

NOTE It is expressed in degrees Celsius (°C).

3.1.6

draw

D

longitudinal movement of a joint

See Figure 1a).

NOTE Draw is expressed in millimetres (mm).

3.1.7

laying length of a bend

L

distance from one end of the bend, excluding the spigot insertion depth, L_i , of a socket end, where applicable, projected along the axis of that end of the bend to the point of intersection with the axis of the other end of the bend

See Figure 8.

NOTE Laying length of a bend is expressed in metres (m).

3.1.8**laying length of a pipe**

internal barrel length

 L

total length of a pipe, L_{tot} , minus, where applicable, the manufacturer's recommended spigot insertion depth, L_i , in the socket

NOTE 1 The laying length of a pipe is expressed in metres (m).

NOTE 2 See 3.1.20 for total pipe length, L_{tot} .

3.1.9**fitting**

component comprising an adaptor, bend or branch

3.1.10**flexible joint**

joint that allows relative movement between the components being joined

3.1.11**minimum crushing load** $q_{cr,min}$

short-term load that a component is required to withstand during a crushing strength test, without failure, corresponding to its nominal size, classification and strength class

NOTE 1 The minimum crushing load is determined using Equation (1) or Equation (2), as applicable (see 5.4.1.1).

NOTE 2 For the purposes of this part of ISO 18672, it is expressed in newtons per millimetre length (N/mm).

3.1.12**misalignment** M

amount by which the centre lines of adjacent pipes fail to coincide

See Figure 1d).

3.1.13**nominal size****DN**

alphanumerical designation of size, for a component with a circular or kite-shaped bore

NOTE 1 It is a convenient round number for reference purposes and is related to the internal diameter when expressed in millimetres.

NOTE 2 The designation for reference or marking purposes consists of the letters DN plus a number, e.g. DN 600.

3.1.14**nominal size****WN/HN**

alphanumerical designation of size for a component with an egg-shaped bore

NOTE 1 It is a convenient round number for reference purposes and is related to the internal width and height (w_i and h_i , see Figures 3 and 6), expressed in millimetres.

NOTE 2 The designation, for reference or marking purposes, consists of the letters WN/HN plus two numbers, e.g. WN/HN 300/450.

3.1.15**non-pressure pipe or fitting**

pipe or fitting not subject to an internal pressure greater than 0,5 bar

3.1.16

normal service conditions

conveyance of surface water, rainwater or sewage, in the temperature range from 2 °C to 50 °C, without pressure, for 50 years

3.1.17

rating factor

multiplication factor that quantifies the relation between a mechanical, physical or chemical property at the service condition and the respective value at 23 °C and 50 % relative humidity

3.1.18

strength class

S_c

constant equal to the minimum short-term crushing load of a component, $q_{cr,min}$, divided by one thousandth of either its nominal size (DN) or nominal width (WN)

NOTE It is expressed in newtons per millimetre length (N/mm).

3.1.19

total draw

D_{tot}

sum of the draw, D , plus the additional longitudinal movement of joint components, J , due to angular deflection, δ

See Figure 1c).

NOTE It is expressed in millimetres (mm).

3.1.20

total pipe length

L_{tot}

distance between two planes normal to the pipe axis and passing through the extreme end points of the pipe

See Figures 2 to 7.

NOTE It is expressed in millimetres (mm).

3.1.21

type tests

tests carried out in order to assess the fitness for purpose of a product or assembly of components to fulfil its or their function(s) in accordance with the product specification

3.1.22

crushing load

crushing strength

q_{cr}

maximum short-term load that a component is able to withstand during a crushing strength test

NOTE It is expressed in newtons per millimetre length (N/mm).

3.1.23

polyester resin concrete

PRC

material formed from mineral aggregates and fillers which are bound together using a polyester resin

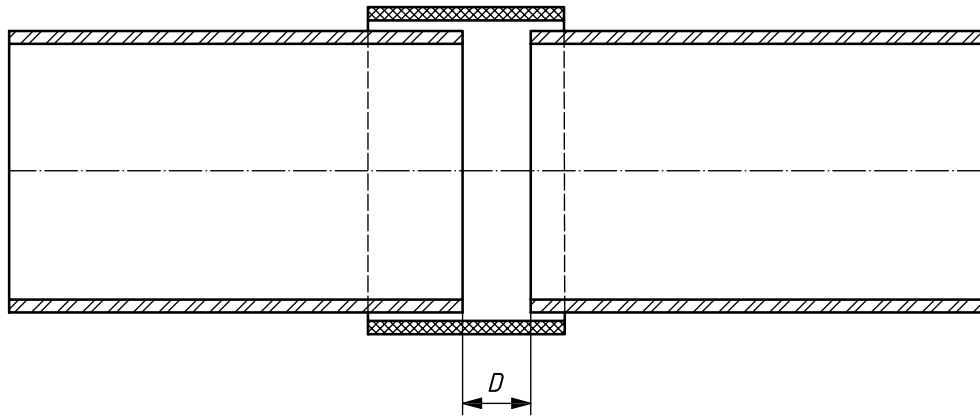

a)

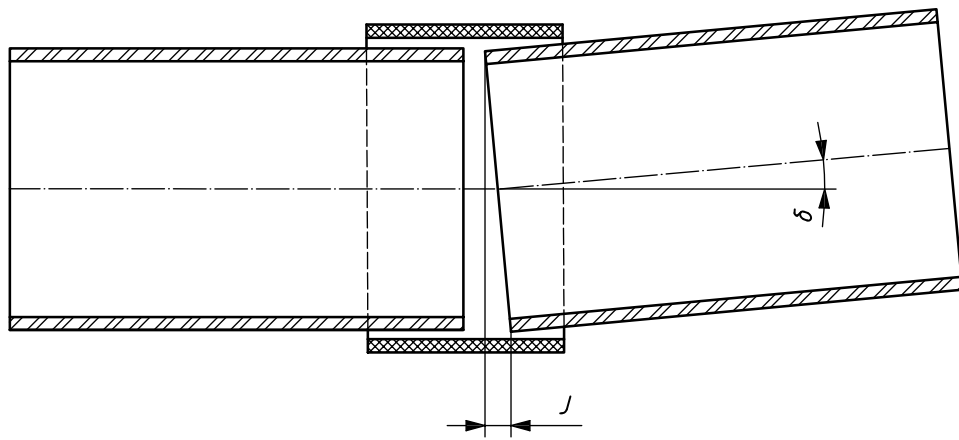

b)

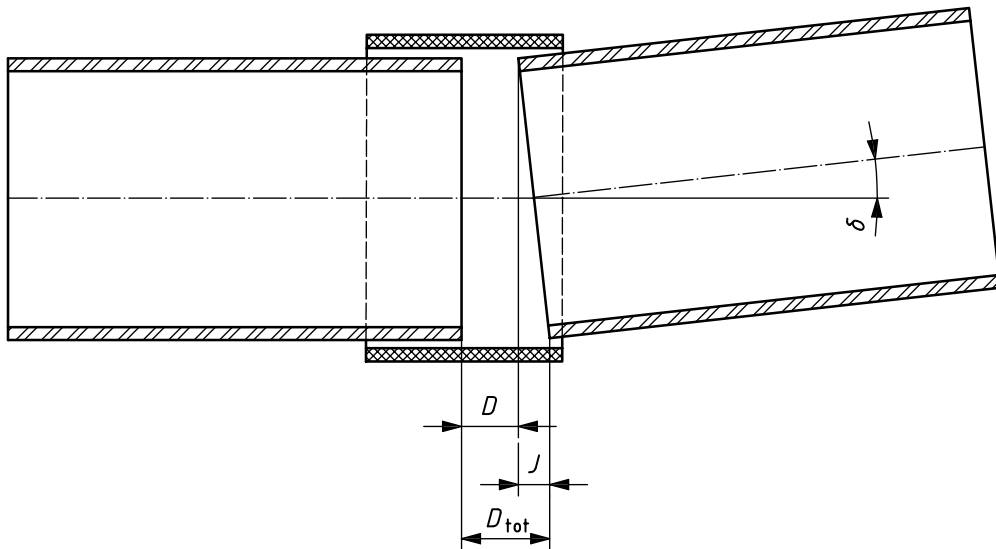

c)

Figure 1 (continued)

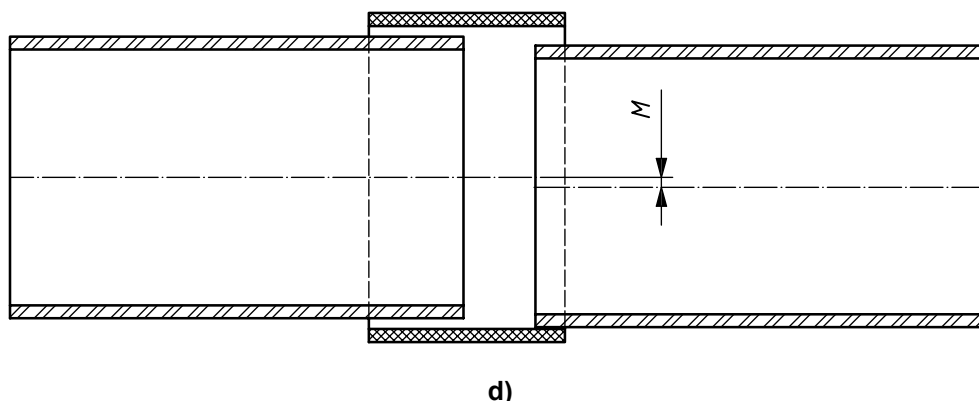

Key

- δ angular deflection
- D draw
- D_{tot} total draw
- J longitudinal movement of the joint due to angular deflection
- M misalignment

Figure 1 — Joint movements

3.2 Symbols and abbreviations

For the purposes of this part of ISO 18672, the symbols given in Table 1 and abbreviations given in Table 2 apply.

Table 1 — Symbols

Symbol	Description	Unit	Where used
a_b	width of a bearing strip	mm	Annexes A and B
B	laying length of a branch pipe	mm	6.3, Figure 9
B_B	nominal offset (body) length of a branch pipe	mm	6.3, Figure 9
B_i	spigot insertion depth of a branch pipe	mm	6.3, Figure 9
b	width of a sawn test piece	mm	5.4.1.2, Annexes B and E
D	draw	mm	3.1.6, 3.1.19, Figure 1, 7.2.2
D_{max}	maximum draw	mm	4.4.2.2, 7.2.2, 7.2.4
D_{tot}	total draw	mm	3.1.19, Figure 1, 7.2.4
d_a	external diameter of a pipe	mm	5.3.1, Figure 2, 5.3.3 to 5.3.6, Figures 4 to 7, 6.2.1.1, 6.3.1.1
d_e	external diameter of a spigot	mm	5.3.4 to 5.3.6, Figures 5 to 7
d_i	internal diameter of a pipe with a circular or kite-shaped cross-section	mm	5.3.1, Figure 2, 5.3.3, Figure 4, 5.3.4, Figure 5, 5.3.6, Figure 7, Annexes A, B and E
e	wall thickness of a pipe with a circular or kite-shaped cross-section or wall thickness of a test piece taken from a pipe	mm	4.1.3, 5.3.1, Figure 2, 5.3.3, Figure 4, 5.3.4, Figure 5, 5.3.6, Figure 7, 6.2.1.1, 6.3.1.1, Annexes A, B and E
e_1	wall thickness at the spring-line of a pipe with egg-shaped cross-section	mm	5.3.2, Figure 3, 5.3.5, Figure 6, Annex A

Table 1 (continued)

Symbol	Description	Unit	Where used
e_2	wall thickness at top of pipe of a pipe with egg-shaped cross-section.	mm	5.3.2, Figure 3, 5.3.5, Figure 6, Annexes A and B
e_3	pedestal height of a pipe with egg-shaped cross-section	mm	5.3.2, Figure 3
f_{corr}	correction factor for stress distribution	—	Annexes B and E
f_{low}	factor for lower load	—	Annex E
f_{up}	factor for upper load	—	Annex E
h_i	internal height of a pipe with egg-shaped cross-section	mm	3.1.14, 5.3.2, Figure 3, 5.3.5, Figure 6
J	longitudinal movement within a joint due to angular deflection, δ (see 3.1.2)	mm	3.1.19, Figure 1, 7.2.4
L	laying length of a pipe or a bend or laying length of the main pipe of a branch fitting	mm	3.1.7, 3.1.8, 4.4.2.2, 5.3.1 to 5.3.6, Figures 2 to 7, 5.3.7.1, 5.4.2.2, 5.5, Figure 8, 6.2.1.5, Figure 9, 6.3.1.4
L_B	nominal body length of the main pipe of a fitting	mm	6.2, Figure 8, 6.3, Figure 9
L_i	insertion depth of the spigot of a pipe or main pipe of a fitting	mm	3.1.7, 3.1.8, 5.3.1 to 5.3.6, Figures 2 to 7, 6.2, Figure 8, 6.3, Figure 9
L_{tot}	total length of a pipe	mm	3.1.8, 3.1.20, Figures 2 to 7, 5.3.1 to 5.3.6
l_a	lever arm length	m	Annexes C and G
l_b	distance between the centres of the bearers	mm	Annexes B, C and E
l_f	distance between the centres of the fulcrums	m	Annex G
l_p	length of a test piece	mm	5.4.1.2, 7.2.4.6, Annexes A, B and E
l_s	support span	m	Annex C
M	misalignment	mm	3.1.12, Figure 1
M_{BMR}	minimum longitudinal bending moment resistance	kNm	5.4.2, Annex C
M_3	calculated longitudinal bending moment resisted by the pipe when tested using three-point loading method	kNm	5.4.2.1, Annex C
M_4	calculated longitudinal bending moment resisted by the pipe when tested using four-point loading method	kNm	5.4.2.1, Annex C
N_d	specified shear load for joint misalignment test	N/mm of nominal size	7.2.4.2
P	test load applied by loading frame	N	Annexes A, B and E
P_b	total bending load applied	kN	Annex C
P_{calc}	calculated minimum test load	N	Annexes A and B
$P_{\text{calc,low}}$	calculated lower limit of cyclic load	N	5.4.4, Annex E
$P_{\text{calc,up}}$	calculated upper limit of cyclic load	N	5.4.4, Annex E

Table 1 (continued)

Symbol	Description	Unit	Where used
P_{cr}	load applied by loading frame at failure	N	Annex A
$P_{eff,CK}$	effective test load applied to a test piece with a circular or kite-shaped cross-section	N	Annex A
$P_{eff,E}$	effective test load applied to a test piece with an egg-shaped cross-section	N	Annex A
P_{min}	minimum load to be applied by loading frame	N	Annexes A and B
q_{cr}	crushing load (or crushing strength) of a pipe calculated from the load applied to the test piece at the moment of failure (collapse)	N/mm	3.1.22, Annexes A and B
$q_{cr,min}$	minimum crushing load	N/mm	3.1.11, 3.1.18, 5.4.1, Annexes A and B
r	radius of curvature	mm	6.2, Figure 8, 6.4
S_C	strength class	N/mm	3.1.11, 3.1.18, 5.2, 5.4.1.1, 5.5, 6.1.1, 6.1.5, 6.4, Annexes A and B
t_{sq}	tolerance on diametrical squareness	mm/m	5.3.1 to 5.3.6, Figures 2 to 7
T_{cube}	height, length and width of a cube sawn from a pipe wall	mm	5.4.3, Annex D
W^*	load due to own weight of the compression beam	N	Annexes A and B
W_p	load due to own weight of a test piece	N	Annex A
W_{pipe}	load due to own weight of a pipe	N/mm of length	Annex B
w_i	internal width of a pipe with an egg-shaped bore	mm	3.1.14, 5.3.2, Figure 3, 5.3.5, Figure 6, Annexes A and B
w_p	width of the pedestal of a pipe with an egg-shaped bore	mm	5.3.2, Figure 3
α_n	fitting angle	degrees	6.2, Figure 8, 6.3, Figure 9, 6.4
δ	angular deflection of a joint	degrees	3.1.2, Figure 1, 3.1.19, 4.4.2.1, 7.2.3
Δ_{str}	deviation from straightness	mm/m	5.3.1 to 5.3.6, Figures 2 to 7
σ_c	calculated compressive strength	N/mm ² ^a	5.4.3
σ_{fat}	calculated fatigue strength	N/mm ²	Annex E
σ_{low}	lower limit of bending tensile stress	N/mm ²	Annex E
σ_{rb}	calculated ring bending tensile stress or strength	N/mm ²	Annexes A and B
$\sigma_{rb,min}$	minimum ring bending tensile stress	N/mm ²	Annexes B and E
σ_{up}	upper limit of bending tensile stress	N/mm ²	Annex E

^a 1 N/mm² = 1 MPa.

Table 2 — Abbreviations

Symbol	Meaning	Where used
BMR	longitudinal bending moment resistance	5.4.2, Annex C
DN	nominal size	1, 3.1.4, 3.1.11, 3.1.13, 3.1.18, 5.2 to 5.5, 6, 7.2.4, Annexes A to C,
HN	nominal internal height of a pipe with egg-shaped cross-section	1, 3.1.4, 3.1.14, 5.2 to 5.5, 6.1, 6.4, Annex A
OC	classification for open-trench construction with circular bore	5.2 to 5.5, 6.1 and 6.4, Annexes A and B
OE	classification for open-trench construction with egg-shaped bore	5.2 to 5.5 and 6.4, Annexes A and B
OK	classification for open-trench construction with kite-shaped bore	5.2 to 5.5 and 6.4, Annexes A and B
PRC	polyester resin concrete	1, 3.1.23, 4.1.3, 4.1.6, 4.3.4, 5.2 to 5.5, 6.1 to 6.4, Annexes A to E
TC	classification for trenchless construction with circular bore	5.2 to 5.5, Annexes A and B
TE	classification for trenchless construction with egg-shaped bore	5.2 to 5.5, Annexes A and B
TK	classification for trenchless construction with kite-shaped bore	5.2 to 5.5, Annexes A and B
WN	nominal internal width of a pipe with egg-shaped cross-section	1, 3.1.4, 3.1.11, 3.1.14, 3.1.18, 5.2 to 5.5, 6.1 to 6.4, 7.2.4, Annexes A and B

4 General requirements

4.1 Materials

4.1.1 General

The pipe or fitting shall be constructed using aggregates, polyester resin (with or without fillers) and, if applicable, additives necessary to impart specific properties to the resin.

4.1.2 Resin

The resin used in the pipe or fitting shall have a temperature of deflection of at least 70 °C, when tested in accordance with Method A of ISO 75-2 with the test specimen in the edgewise position. It shall also conform to the applicable requirements of EN 13121-1.

4.1.3 Aggregates and fillers

Aggregates and fillers shall not contain constituents in such quantities as may be detrimental to the curing, strength, leaktightness or durability of the polyester resin concrete (PRC) (see 3.1.23). The size of particles in aggregates and fillers shall not exceed one third of the smallest wall thickness, e , of the pipe or fitting.

4.1.4 Elastomers

Each elastomeric material of the sealing component shall conform to EN 681-1. The sealing component shall be supplied by the pipe or fitting manufacturer either attached to the pipe or fitting, or separately.

4.1.5 Metals

When exposed metal components are used, there shall be no evidence of corrosion of the components after the metallic item has been immersed for seven days at (23 ± 2) °C in an aqueous sodium chloride solution, 30 g/l, and then removed from the solution and visually examined for evidence of corrosion.

4.1.6 Minimum resin content

When tested in accordance with ISO 7510 the content of resin in the polyester resin concrete (PRC) shall be not less than 7 % mass fraction of the sample.

4.2 Appearance

Both internal and external surfaces shall be free of irregularities which would impair the ability of the component to conform to the requirements of this part of ISO 18672. The edges of the pipe faces shall be free of cracks or burrs and the joint surfaces shall be free of irregularities that would preclude the formation of a leaktight seal. The ends of a component shall be square to its longitudinal axis within the tolerances specified in Clause 5, Tables 4 to 9, as applicable.

4.3 Reference conditions for testing

4.3.1 Temperature

The mechanical, physical and chemical properties specified in this part of ISO 18672 shall be determined at (23 ± 5) °C. For service temperatures over 35 °C and up to and including 50 °C, type tests shall be carried out at least at the purchaser's declared design service temperature (see 3.1.5) to establish rating factors (see 3.1.17) for all long-term properties to be used in design.

4.3.2 Properties of water for testing

The water used for the tests referred to in this part of ISO 18672 shall be tap water having a pH of (7 ± 2) .

4.3.3 Loading conditions

The mechanical, physical and chemical properties specified in this part of ISO 18672 shall be determined using circumferential and/or longitudinal loading conditions, as applicable.

4.3.4 Measurement of dimensions

The dimensions of the polyester resin concrete (PRC) components and the joints shall be determined at (23 ± 5) °C. Measurements shall be made either in accordance with ISO 3126 or using any method of sufficient accuracy to determine conformity or otherwise to the applicable limits. Routine measurements shall be determined at the prevailing temperature or if the manufacturer prefers, at (23 ± 5) °C.

4.4 Joints

4.4.1 General

The manufacturer shall declare the length and the maximum external diameter or, for egg-shaped components, the maximum dimensions of the assembled joint, and the materials used, in documents at the time of the enquiry or delivery.

4.4.2 Flexibility of the jointing system

4.4.2.1 Maximum angular deflection

The manufacturer shall declare the maximum value of the angular deflection, δ , for which each joint is designed, in writing at the time of enquiry or delivery.

4.4.2.2 Maximum draw

The manufacturer shall declare the maximum draw, D_{\max} (see Figure 1), for which each joint is designed, in writing at the time of enquiry or delivery. For flexible joints, the maximum draw, which includes temperature effects, shall not be less than 0,2 % of the laying length, L , of the longest pipe with which it is intended to be used.

4.4.3 Joint seals

Elastomeric joint seals shall be made from material conforming to EN 681-1. They shall be supplied by the pipe manufacturer and shall either be integrated into the unit or supplied separately. A sealing ring shall not have any detrimental effect on the properties of the components with which it is used and shall not cause the test assembly to fail the functional requirements of Clause 7.

4.4.4 Adhesives

When the components of a joint are to be connected using adhesives, the adhesives to be used shall be specified by the manufacturer of the joint in writing at the time of enquiry or delivery. The joint manufacturer shall ensure that the adhesives do not have any detrimental effects on the components with which they are used and they shall not cause the test assembly to fail the functional requirements of Clause 7.

5 Pipes

5.1 Classification

5.1.1 General

Pipes shall be classified (see Tables 2 and 3) according to

- a) the intended method of installation, i.e. whether open-trench construction or trenchless construction, and
- b) the bore shape, i.e. whether circular, egg-shaped or kite-shaped.

5.1.2 Method of installation

Pipes intended to be installed using open-trench techniques shall be classified as such by the use of the letter "O" in their designation.

Pipes intended to be installed using trenchless techniques, such as jacking, shall be classified as such by the use of the letter "T" in their designation.

5.1.3 Bore shape

Pipes having a bore shape that is circular shall be classified by the use of the letter "C" in their designation.

Pipes having a bore shape that is egg-shaped shall be classified by the use of the letter "E" in their designation.

Pipes having a bore shape that is kite-shaped shall be classified by the use of the letter “K” in their designation.

5.2 Designation

A pipe made in accordance with this part of ISO 18672 shall be designated by adding the appropriate letters from 5.1.2 and 5.1.3 to the letters PRC, which indicate that it is manufactured from polyester resin concrete. This procedure produces the designations with respect to the pipe’s classification shown in Table 3.

Table 3 — Designation of polyester resin concrete (PRC) pipes with respect to the classification

Bore shape		Designation	
		Open-trench construction O	Trenchless construction, such as pipe jacking T
Circular	C	PRC-OC	PRC-TC
Egg-shaped	E	PRC-OE	PRC-TE
Kite-shaped	K	PRC-OK	PRC-TK

The complete designation of a pipe consists of the number of this part of ISO 18672, the designation with respect to the classification (see Table 3), the nominal size and the strength class, S_c . The strength class shall be taken from Table 10, Table 11 or Table 12, as applicable, relative to the pipe’s nominal size, DN or WN/HN, and classification.

EXAMPLE The designation of a pipe with a kite-shaped bore, a nominal size DN 800 and a strength class $S_c = 120$ N/mm, to be installed using open-trench construction, shall be as follows:

ISO 18672-1 PRC-OK DN 800 $S_c = 120$ N/mm

5.3 Geometrical characteristics

5.3.1 Polyester resin concrete (PRC) pipes with circular bore for installation in open trenches — PRC-OC

When measured in accordance with 4.3.4, the dimensions d_i , L , Δ_{str} and t_{sq} (see Figure 2) shall conform to the applicable values and tolerances according to Table 4 and 5.3.7. The dimensions e , d_a , L_i , L_{tot} and their tolerances shall be specified by the manufacturer in writing at the time of enquiry or delivery.

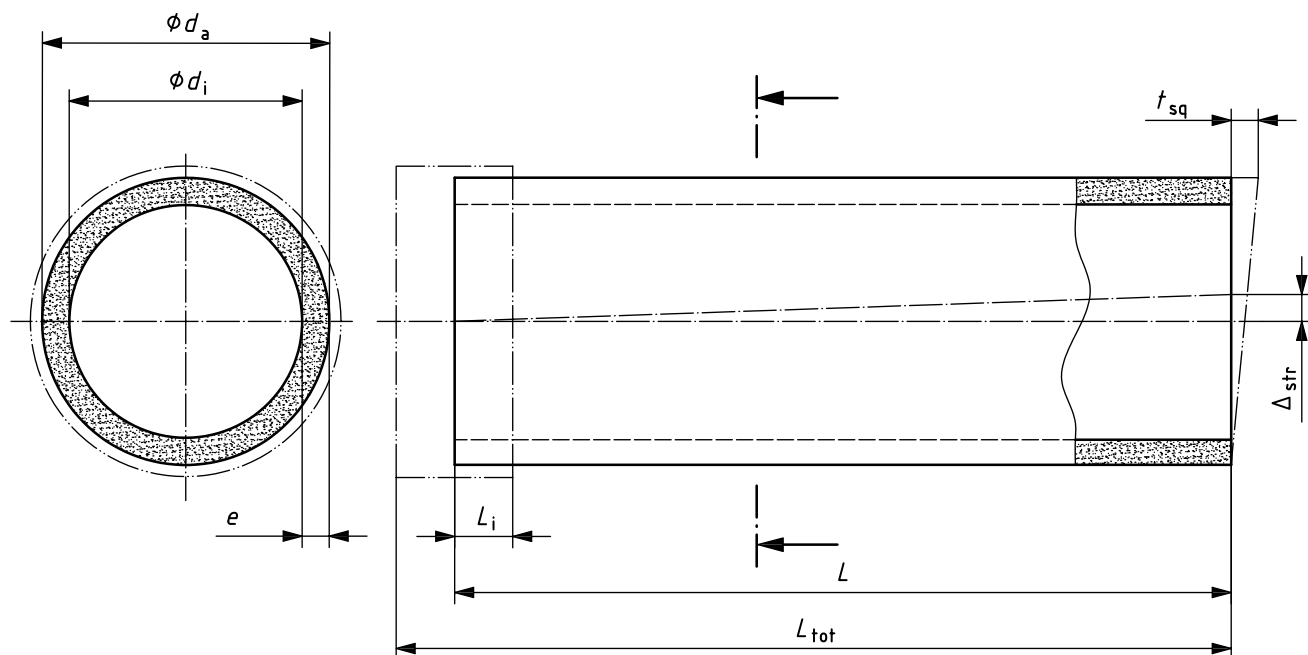

Key

- Δ_{str} deviation from straightness
- d_a external diameter
- d_i internal diameter
- e pipe wall thickness
- L laying length
- L_i insertion depth of spigot
- L_{tot} total length
- t_{sq} tolerance on diametrical squareness

Figure 2 — Specified dimensions for pipes designated PRC-OC

Table 4 — Dimensional requirements for pipes designated PRC-OC

Nominal size DN ^a	Internal diameter		Maximum deviation from straightness $\Delta_{str,max}$ mm/m	Maximum tolerance on diametrical squareness $t_{sq,max}$ mm/m
	d_i mm	tolerance mm		
150	150	± 3	5	3
200	200			
250	250			
300	300			
400	400	± 4	6	4
500	500	± 5		
600	600	± 6	7	5
700	700			
800	800			
900	900			
1000	1 000			
1200	1 200	± 10	8	6
1400	1 400			
1500	1 500			
1600	1 600			
1800	1 800	± 12	8	7
2000	2 000			
2200	2 200			
2400	2 400			
2600	2 600			
2800	2 800			
3000	3 000			

^a Applicable dimensions shall be interpolated between the nearest values in this table for other nominal sizes.

5.3.2 Polyester resin concrete (PRC) pipes with egg-shaped bore for installation in open trenches — PRC-OE

When measured in accordance with 4.3.4, the dimensions w_i , h_i , L , w_p , Δ_{str} and t_{sq} (see Figure 3) shall conform to the applicable values and tolerances according to Table 5 and 5.3.7. The dimensions e_1 , e_2 , e_3 , L_i , L_{tot} and their tolerances shall be specified by the manufacturer in writing at the time of enquiry or delivery.

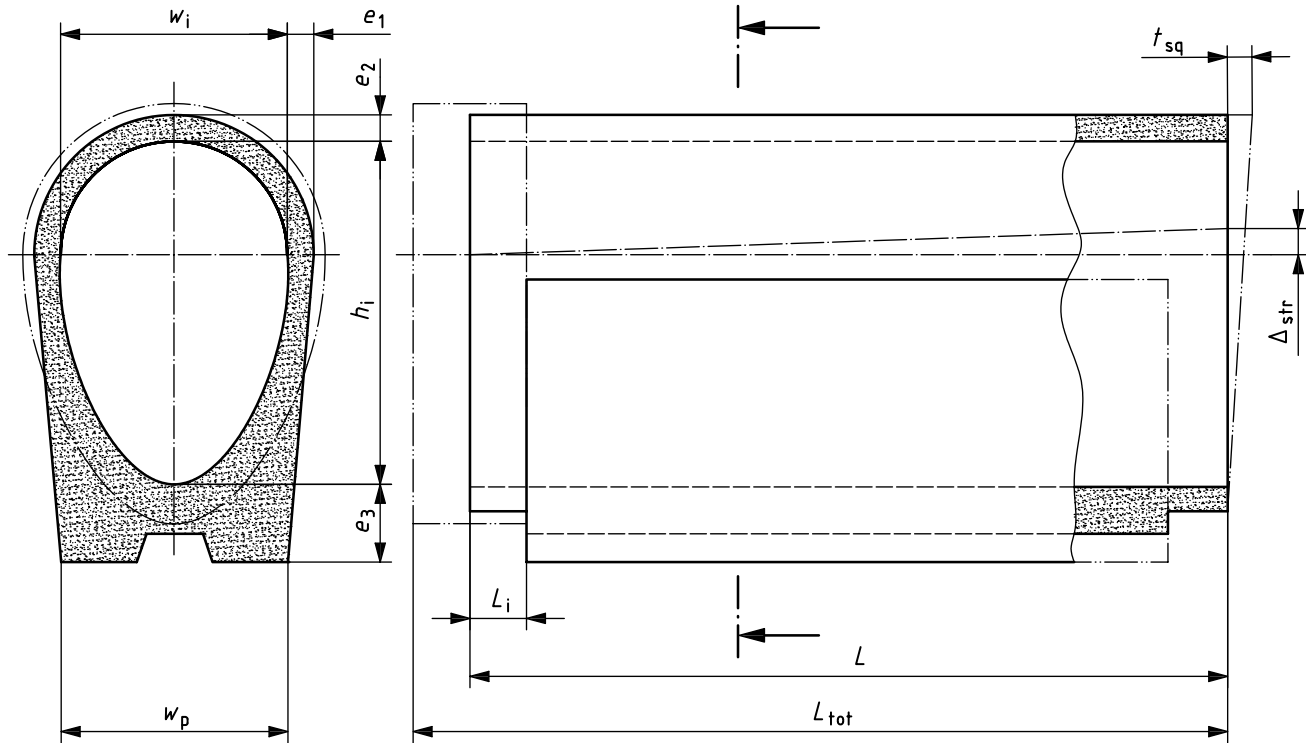

Key

- | | | | |
|----------------|------------------------------|-----------|-------------------------------------|
| Δ_{str} | deviation from straightness | L_i | insertion depth of a spigot |
| e_1 | wall thickness at springline | L_{tot} | total length |
| e_2 | wall thickness at top | t_{sq} | tolerance on diametrical squareness |
| e_3 | height of pedestal | w_i | internal width |
| h_i | internal height | w_p | width of pedestal |
| L | laying length | | |

Figure 3 — Specified dimensions for pipes designated PRC-OE

Table 5 — Dimensional requirements for pipes designated PRC-OE

Nominal size WN/HN ^a	Internal dimensions			Minimum pedestal width $w_{p,min}$ mm	Maximum deviation from straightness $\Delta_{str,max}$ mm/m	Maximum tolerance on diametrical squareness $t_{sq,max}$ mm/m
	w_i mm	h_i mm	tolerance mm			
300/450	300	450	± 3	180	5	3
400/600	400	600	± 4	240	6	4
500/750	500	750	± 5	300		
550/1000	550	1 000		330		
600/900	600	900		360		
700/1050	700	1 050	± 6	420	7	5
700/1200	700	1 200		420		
800/1200	800	1 200		480		
850/1400	850	1 400		510		
900/1350	900	1 350		540		
1000/1500	1 000	1 500	± 10	600	8	6
1200/1800	1 200	1 800		720		
1400/2100	1 400	2 100		840		

^a Applicable dimensions shall be interpolated between the nearest values in this table for other nominal sizes.

5.3.3 Polyester resin concrete (PRC) pipes with kite-shaped cross-section for installation in open trenches — PRC-OK

When measured in accordance with 4.3.4, the dimensions d_i , L , Δ_{str} and t_{sq} (see Figure 4) shall conform to the applicable values and tolerances according to Table 6 and 5.3.7. The dimensions e , d_a , L_i , L_{tot} and their tolerances shall be specified by the manufacturer in documents at the time of the enquiry or delivery.

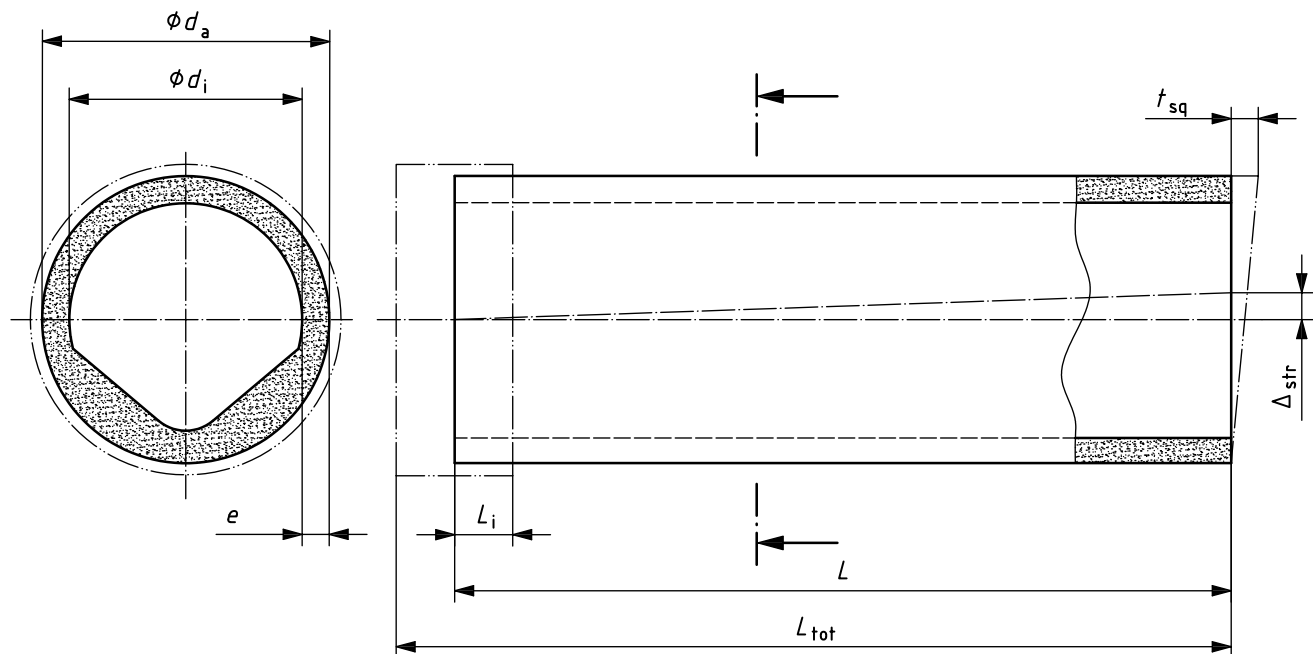

Key

- Δ_{str} deviation from straightness
- d_a external diameter
- d_i internal diameter at springline
- e wall thickness at springline
- L laying length
- L_i insertion depth of a spigot
- L_{tot} total length
- t_{sq} tolerance on diametrical squareness

Figure 4 — Specified dimensions for pipes designated PRC-OK

Table 6 — Dimensional requirements for pipes designated PRC-OK

Nominal size DN ^a	Internal diameter		Maximum deviation from straightness $\Delta_{str,max}$ mm/m	Maximum tolerance on diametrical squareness $t_{sq,max}$ mm/m
	d_i mm	tolerance mm		
800 900 1000	800 900 1 000	± 6	7	5
1200 1400 1600 1800	1 200 1 400 1 600 1 800	± 10	8	6

^a Applicable dimensions shall be interpolated between the nearest values in this table for other nominal sizes.

5.3.4 Polyester resin concrete (PRC) pipes with circular cross-section for installation using trenchless techniques — PRC-TC

When measured in accordance with 4.3.4, the dimensions d_a , L , Δ_{str} and t_{sq} (see Figure 5) shall conform to the applicable values and tolerances according to Table 7 and 5.3.7. The dimensions e , d_i , d_e , L_i , L_{tot} and their tolerances shall be specified by the manufacturer in writing at the time of enquiry or delivery.

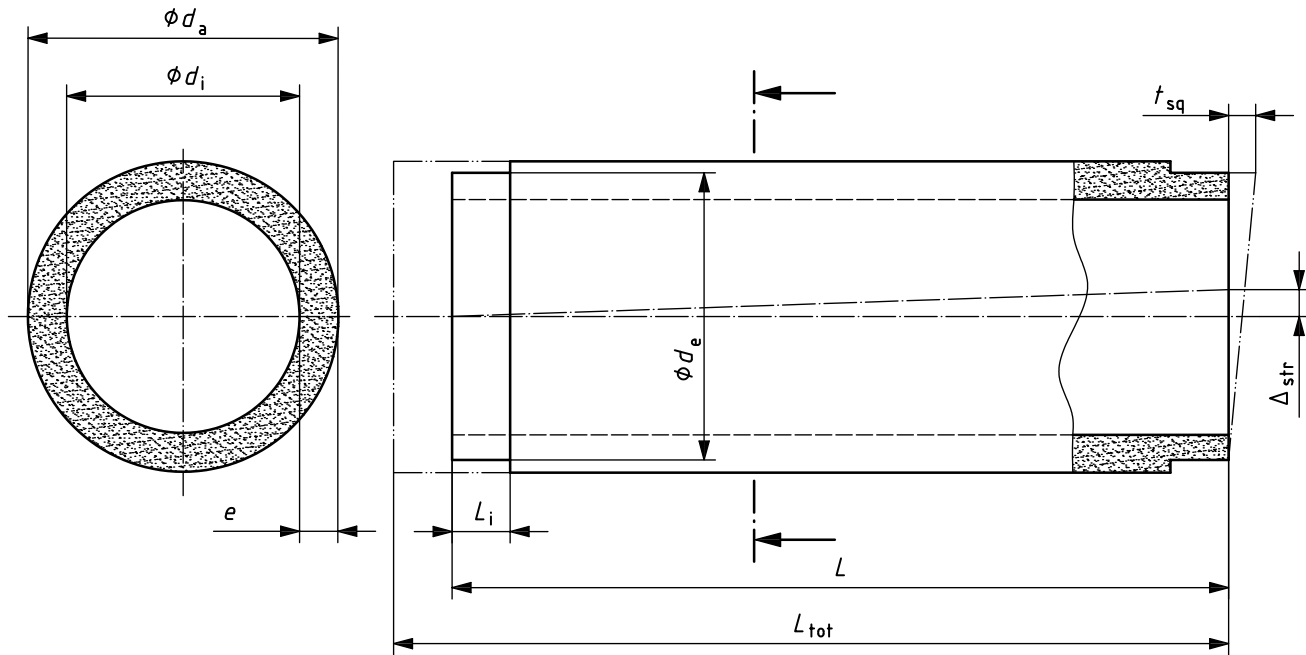

Key

- | | |
|--|--|
| Δ_{str} deviation from straightness | L laying length |
| d_a external diameter | L_i insertion depth of a spigot |
| d_e external diameter of a spigot | L_{tot} total length |
| d_i internal diameter at springline | t_{sq} tolerance on diametrical squareness |
| e wall thickness at springline | |

Figure 5 — Specified dimensions for pipes designated PRC-TC

Table 7 — Dimensional requirements for pipes designated PRC-TC

Nominal size DN ^a	External diameter		Maximum deviation from straightness $\Delta_{str,max}$ mm/m	Maximum tolerance on diametrical squareness $t_{sq,max}$ mm/m
	d_a mm	tolerance mm		
150 200 250 300 400 500	210 275 360 400 550 660	± 5	5	1,0
600 700 800 900 1000	760 860 960 1 100 1 185	± 6		
1200 1400 1500 1600 1800 2000	1 485 1 720 1 820 1 940 2 160 2 400	± 7	10	1,5
2200 2400 2500 2600	2 630 2 870 2 985 3 100	± 8	15	

^a Applicable dimensions shall be interpolated between the nearest values in this table for other nominal sizes.

5.3.5 Polyester resin concrete (PRC) pipes with egg-shaped internal cross-section and circular external cross-section for installation using trenchless techniques — PRC-TE

When measured in accordance with 4.3.4, the dimensions d_a , L , Δ_{str} and t_{sq} (see Figure 6) shall conform to the applicable values and tolerances according to Table 8 and 5.3.7. The dimensions d_e , e_1 , e_2 , h_i , L_i , L_{tot} and w_i and their tolerances shall be specified by the manufacturer in writing at the time of enquiry or delivery.

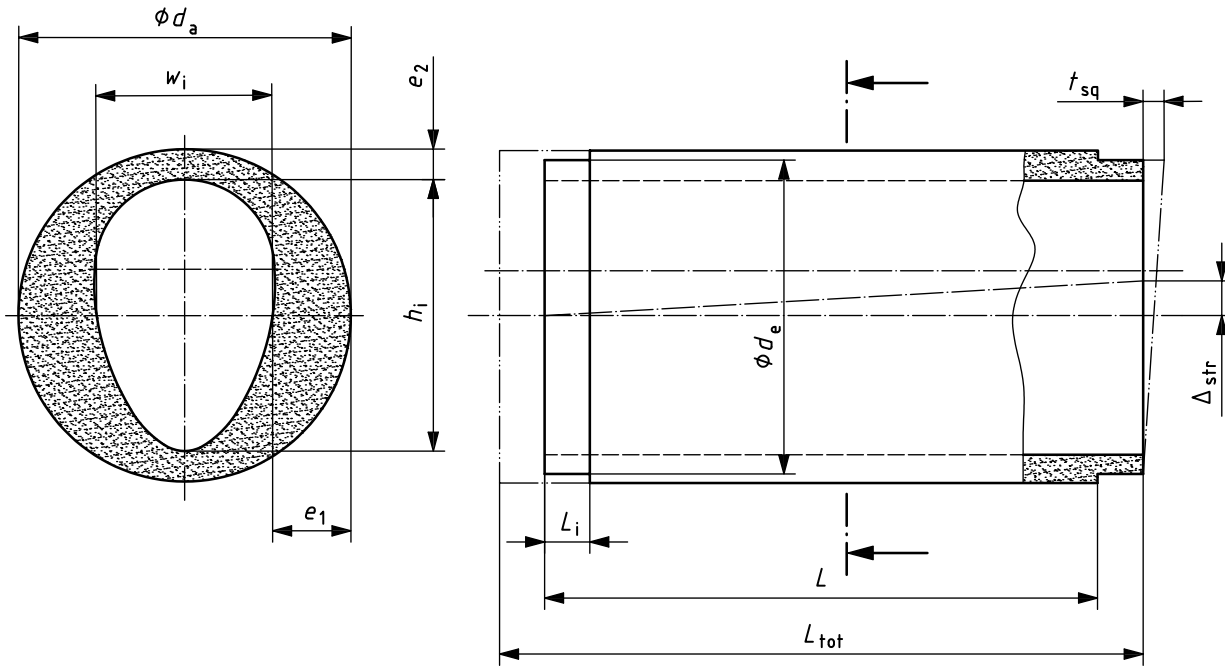

Key

- Δ_{str} deviation from straightness
- d_a external diameter
- d_e external diameter of a spigot
- e_1 wall thickness at springline
- e_2 wall thickness at top of pipe
- h_i internal height
- L laying length
- L_i insertion depth of a spigot
- L_{tot} total length
- t_{sq} tolerance on diametrical squareness
- w_i internal width at springline

Figure 6 — Specified dimensions for pipes designated PRC-TE

Table 8 — Dimensional requirements for pipes designated PRC-TE

Nominal width/height WN/HN ^a	External diameter		Maximum deviation from straightness $\Delta_{str,max}$ mm/m	Maximum tolerance on diametrical squareness $t_{sq,max}$ mm/m
	d_a mm	tolerance mm		
300/450	660	± 5	5	1,0
400/600	760	± 6		
500/750	960			
600/900	1 100			
550/1000	1 185			
700/1050	1 310	± 7	10	1,5
700/1200	1 485			
800/1200	1 485			
850/1400	1 720			
900/1350	1 720			
1000/1500	1 820			
1200/1800	2 160			
1400/2100	2 520	± 8		

^a Applicable dimension shall be interpolated between the nearest values in this table for other nominal sizes.

5.3.6 Polyester resin concrete (PRC) pipes with kite-shaped internal cross-section and circular external cross-section for installation using trenchless techniques — PRC-TK

When measured in accordance with 4.3.4, the dimensions d_a , L , Δ_{str} and t_{sq} (see Figure 7) shall conform to the applicable values and tolerances according to Table 9 and 5.3.7. The dimensions e , d_i , d_e , L_i , L_{tot} and their tolerances shall be specified by the manufacturer in documents at the time of the enquiry or delivery.

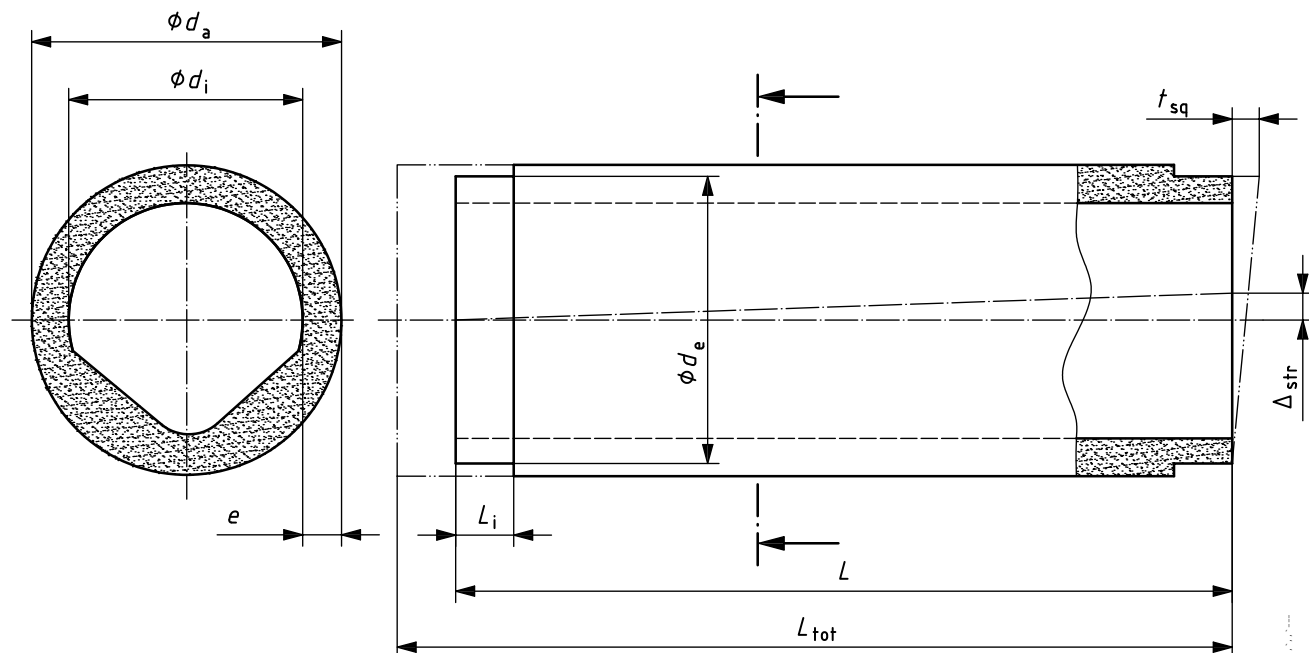

Key

- Δ_{str} deviation from straightness
- d_a external diameter
- d_e external diameter of a spigot
- d_i internal diameter at springline
- e wall thickness at springline
- L laying length
- L_i insertion depth of a spigot
- L_{tot} total length
- t_{sq} tolerance on diametrical squareness

Figure 7 — Specified dimensions for pipes designated PRC-TK

Table 9 — Dimensional requirements for pipes designated PRC-TK

Nominal size DN ^a	External diameter		Maximum deviation from straightness	Maximum tolerance on diametrical squareness
	d_a mm	tolerance mm	$\Delta_{str,max}$ mm/m	$t_{sq,max}$ mm/m
800 900 1000	960 1 100 1 185	± 6	5	1,0
1200 1400 1500 1600 1800	1 485 1 720 1 820 1 940 2 160	± 7	10	1,5

^a Applicable dimensions shall be interpolated between the nearest values in this table for other nominal sizes.

5.3.7 Laying lengths (internal barrel lengths)

5.3.7.1 Pipes designated PRC-OC, PRC-OE and PRC-OK

The laying length, *L* (see 3.1.8), shall be one of the following values:

- for DN ≤ 250: 2 m ± 10 mm;
- for DN > 250: 2 m ± 10 mm or 3 m ± 10 mm;
- for WN: 2 m ± 10 mm.

NOTE Laying lengths other than these can be supplied by agreement between the manufacturer and the purchaser using the same tolerance.

5.3.7.2 Pipes designated PRC-TC, PRC-TE and PRC-TK

The laying length shall be one of the following values:

- for DN or WN ≤ 400: 1 m ± 10 mm or 2 m ± 10 mm;
- for DN or WN > 400 and DN or WN ≤ 1000: 2 m ± 10 mm;
- for DN or WN > 1000: 3 m ± 10 mm.

NOTE Laying lengths other than these can be supplied by agreement between the manufacturer and the purchaser, using the same tolerance.

5.4 Mechanical characteristics

5.4.1 Crushing strength

5.4.1.1 Requirements

A pipe shall withstand the applicable minimum crushing load, $q_{cr,min}$, corresponding to its nominal size, classification and strength class, S_c , as given in Table 10, Table 11 or Table 12, as applicable.

The minimum crushing load, $q_{cr,min}$, is determined using Equation (1) or Equation (2), as applicable:

$$q_{cr,min} = S_c \times [DN] \times 0,001 \tag{1}$$

$$q_{cr,min} = S_c \times [WN] \times 0,001 \tag{2}$$

It is expressed in newtons per millimetre length (N/mm).

Table 10 — Minimum strength classes for pipes designated PRC-OC or PRC-TC

Nominal size DN	Strength class S_c N/mm	
	PRC-OC	PRC-TC
150 ≤ DN ≤ 500	140	160
600 ≤ DN ≤ 1000	120	140
1200 ≤ DN ≤ 3000	90	120

Table 11 — Minimum strength classes for pipes designated PRC-OE or PRC-TE

Nominal width/height WN/HN	Strength class S_c N/mm	
	PRC-OE	PRC-TE
$300/450 \leq WN/HN \leq 600/900$	140	160
$700/1050 \leq WN/HN \leq 1000/1500$	120	140
$1200/1800 \leq WN/HN \leq 1400/2100$	90	120

Table 12 — Minimum strength classes for pipes designated PRC-OK or PRC-TK

Nominal size DN	Strength class S_c N/mm	
	PRC-OK	PRC-TK
$800 \leq DN \leq 1000$	120	140
$1200 \leq DN \leq 1800$	90	120

The pipe shall be tested in accordance with Annex A, or, if suitable apparatus is not available, in accordance with Annex B using test pieces sawn from a pipe.

5.4.1.2 Test pieces

When testing in accordance with Annex A, the test piece shall be a length of pipe, with or without a socket, with a laying length of at least the applicable value from Table 13.

When testing in accordance with Annex B, the test piece shall be a piece sawn from a pipe or a broken piece of a pipe. When testing pipes with kite-shaped or egg-shaped cross-section the test piece shall be taken from the top of the pipe. The test piece shall have parallel boundary surfaces. The length, l_p , in the circumferential direction, shall be about five times the wall thickness and its width, b , in the longitudinal direction, about three times the wall thickness. The longitudinal sides of the test piece shall be perpendicular to the generated surface of the pipe. Three test pieces shall be taken from a pipe and the average of the results from the three tests is the test result.

Table 13 — Minimum length of a test piece

Nominal size DN	Nominal size WN/HN	Minimum length l_p mm
$DN < 300$	$WN/HN < 300/450$	DN (or WN)
$300 \leq DN \leq 1500$	$300/450 \leq WN/HN \leq 1000/1500$	300
$DN > 1500$	$WN/HN > 1000/1500$	$0,2 \times DN$ (or WN)

5.4.2 Longitudinal bending moment resistance

5.4.2.1 Requirements

Pipes with an external circular shape having laying lengths greater than six times their (vertical) internal diameter shall withstand the required longitudinal bending moment when tested with one of the methods described in Annex C. For pipes designated PRC-OC or PRC-TC, having a nominal size of up to and including DN 400 and standard laying lengths as given in 5.3.7, the applicable minimum longitudinal bending moment resistance (BMR) is specified in Table 14.

The test is continued until the test piece fails, whereupon the maximum load and the calculated bending moment, M_3 or M_4 , as applicable, shall be recorded.

Table 14 — Minimum longitudinal bending moment resistance, M_{BMR}

Nominal size DN	Minimum longitudinal bending moment resistance M_{BMR} kNm	
	PRC-OC	PRC-TC
150	2,7	3,0
200	5,7	6,2
250	8,3	8,8
300	9,9	10,5
400	11,6	12,6

For pipes with non-standard laying lengths which are greater than those given in 5.3.7 and also greater than six times their (vertical) internal diameter, the appropriate value for M_{BMR} shall be agreed between the manufacturer and the purchaser, based upon suitable calculation models.

5.4.2.2 Test pieces

The test piece shall be a whole pipe, with or without a socket, with a laying length, L , of at least 1 250 mm or six times its internal diameter, whichever is the greater. If a whole pipe is shorter than six times its internal diameter then this test does not need to be performed.

Three test pieces, of the same size, classification and strength class, shall be used. The average of the results from the three tests is the test result.

5.4.3 Compressive strength of polyester resin concrete

5.4.3.1 Requirements

The polyester resin concrete (PRC) used to manufacture PRC-TC, PRC-TE or PRC-TK pipes shall be tested in accordance with Annex D. When tested, the test pieces complying with 5.4.3.2 shall have a compressive strength, σ_c , of not less than 80 N/mm² 2).

2) 1 N/mm² = 10⁶ N/m² = 1 MPa

5.4.3.2 Test pieces

The test piece shall be a cube of polyester resin concrete (PRC) sawn from a pipe, having height, length and width equal to T_{cube} (see Figure D.1).

Three test pieces shall be used.

5.4.4 Fatigue strength under pulsating stress

5.4.4.1 Requirements

When tested in accordance with Annex E, all test pieces shall withstand at least 2×10^6 cycles, with the load cycling between $P_{\text{calc,low}}$ and $P_{\text{calc,up}}$ at a frequency not greater than 12 Hz, without failure.

5.4.4.2 Test pieces

The test piece shall be sawn from a pipe. The test piece is cut to produce a rectangular shape whose length, in the circumferential direction, is approximately five times the wall thickness and whose width, in the longitudinal direction, is approximately three times the wall thickness.

Three test pieces taken from the same pipe shall be used. The average of the results from the three tests is the test result.

5.4.5 Leaktightness

5.4.5.1 Requirements

Pipes and their joints for applications covered by this part of ISO 18672 are required to be leaktight against internal and external pressure between 0 bar and 0,5 bar.

When tested in accordance with Annex F, test pieces conforming to 5.4.5.2 shall withstand an internal pressure of 1 bar for 15 min without any signs of leaks, damp patches or droplets.

5.4.5.2 Test pieces

A test piece either consists of a complete pipe and its joint or two pieces of pipe and a joint. One test piece shall be used.

5.4.6 Long-term crushing strength under media attack

5.4.6.1 Requirements

This test is used to determine the percentage reduction in strength over 50 years. The manufacturer shall declare the result from this long-term type test in documents at the time of the enquiry or delivery. When tested in accordance with Annex G, an extrapolated long-term crushing strength of a pipe (after 50 years under load), expressed as a percentage of initial strength, is determined. This value shall not be less than 50 % of the initial strength. This extrapolated value gives the load that pipes are capable of being subjected to, without failure, for 50 years, when exposed to acid or alkali solution, as described in Annex G.

The procedure described in Annex G may be used to take into account the influence of any particular solution on the long-term crushing strength of a pipe. In such cases, the acceptable percentage value of strength reduction shall be agreed between the manufacturer of the polyester resin concrete (PRC) units and the purchaser.

5.4.6.2 Test pieces

A test piece consists of a pipe section having a minimum length conforming to the applicable requirements given in Table 13, with its ends cut plane and perpendicular to the longitudinal axis.

For a test series, at least 18 test pieces shall be used.

5.5 Marking of pipes

Marking details shall be printed or formed directly on the pipe in such a way that the marking does not initiate cracks or other types of failure. If printing is used, the colouring of the printed information shall differ from the basic colouring of the product and such that the markings shall be readable without magnification.

The following marking shall be on the outside of each pipe of DN 500 or less and, in the case of pipes of DN 600 or greater, shall be either on the inside or on the outside surface:

- a) the number of this part of ISO 18672, i.e. ISO 18672-1;
- b) the designation with respect to the classification, i.e. PRC-OC, PRC-OE, PRC-OK, PRC-TC, PRC-TE or PRC-TK;
- c) the nominal size, DN or WN/HN;
- d) the strength class, S_c ;
- e) the laying length, L ;
- f) the manufacturer's name or identification;
- g) the date or code of manufacture;
- h) quality mark, if applicable.

6 Fittings

6.1 General

6.1.1 Designation of bends and branches

Bends and branches shall be designated according to 5.2 and Table 3 in respect of the following:

- a) the intended method of installation, i.e. open-trench construction (O);
- b) the cross-sectional shape, i.e. whether circular (C), egg-shaped (E) or kite-shaped (K);
- c) the nominal size, DN or WN/HN;
- d) the strength class, S_c .

EXAMPLE The designation of a bend with a circular bore shape, a nominal size DN 600 and a strength class $S_c = 120$ N/mm shall be as follows:

ISO 18672-1 PRC-OC DN 600 $S_c = 120$ N/mm



6.1.2 Method of installation

The method of installation for bends and branches in accordance with this part of ISO 18672 is open-trench (O).

6.1.3 Cross-sectional shape

The cross-sectional shape (C, E or K) of the fitting shall be that of the straight length of pipe to which it is to be joined in the piping system and shall be one of the shapes specified in 5.1.3.

6.1.4 Nominal size DN or WN/HN

The nominal size, DN or WN/HN, of the fitting shall be that of the straight length of pipe to which it is to be joined in the piping system and shall be one of the nominal sizes given in 5.3.

6.1.5 Strength class

The strength class, S_C , of the fitting shall be that of the straight length of pipe to which it is to be joined in the piping system. It shall be taken from Table 10, Table 11 or Table 12, as applicable, relative to the pipe's nominal size, DN or WN/HN, and designation with respect to the classification (see Table 3).

6.2 Bends

6.2.1 Geometrical characteristics

6.2.1.1 General

The dimensions measured in accordance with 4.3.4 shall conform to the applicable values and tolerances according to 6.2.1.2 to 6.2.1.5. The dimensions, e , d_a , L_i , and their tolerances, shall be specified by the manufacturer in writing at the time of enquiry or delivery.

6.2.1.2 Diameter

The tolerance on the diameter of the bend at the spigot positions shall conform to the applicable requirements in 5.3.

6.2.1.3 Nominal fitting angle

In the interests of rationalization, the nominal fitting angle, α_n , which indicates the angular change in direction of the axis of the bend (see Figure 8) shall be one of the following preferred values, 15°, 30°, 45°, 60° or 90°. The deviation of the actual change in direction of a bend from the designated fitting angle shall not exceed 1° of the specified angle.

NOTE Fitting angles other than these can be supplied by agreement between the purchaser and the manufacturer.

6.2.1.4 Radius of curvature

Bends made by fabrication from straight pipe (see Figure 8) shall not provide more than 30° angular change for each segment of the bend. The base of each segment shall have sufficient length adjacent to each joint to ensure that external wrapping or joining materials can be accommodated. The radius of curvature, r , shall not be less than the nominal size, DN or WN, in millimetres, of the pipe.

The specified dimensions of the bends in this part of ISO 18672 are based on a radius of curvature of $r = 1,5 \times [\text{DN}]$ or $r = 1,5 \times [\text{WN}]$, in millimetres.

NOTE Radii of curvature other than those described can be supplied by agreement between the purchaser and the manufacturer.

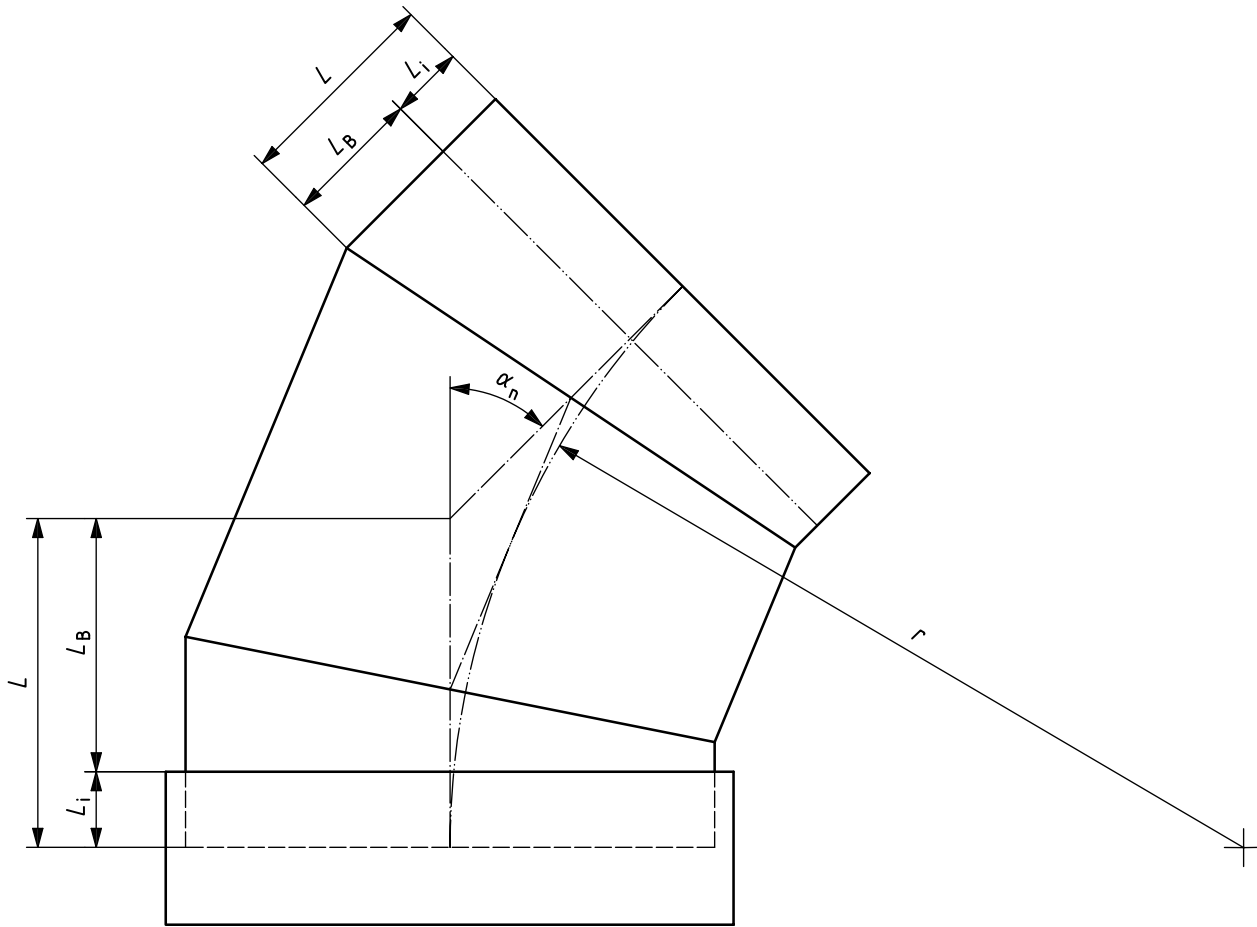

Key

- | | |
|--------------------------|---------------------------------|
| α_n fitting angle | L_i insertion depth of spigot |
| L laying length | r radius of curvature |
| L_B body length | |

Figure 8 — Typical fabricated bend

6.2.1.5 Lengths

6.2.1.5.1 General

Lengths of individual bends are dependent upon the designated fitting angle, the radius of curvature and the length of any linear extensions provided for jointing or other purposes.

6.2.1.5.2 Laying length

The laying length, L , of the bend shall be the distance from one end of the bend, excluding the spigot insertion depth of a socket end where applicable, projected along the axis of that end of the bend to the point of intersection with the axis of the other end of the bend (see Figure 8).

For an end of a bend containing a spigot, the laying length, L , is the body length, L_B , plus the insertion depth of the joint, L_i (see Figure 8).

The permitted deviations on the declared or specified dimensions for laying length shall be ± 15 mm times the number of mitres of the bend.

6.2.1.5.3 Body length

The body length of the bend, L_B , shall be the distance from the point of intersection of the two axes of the bend to a point on either axis, equal to the laying length, L , minus an insertion depth, L_i . Nominal body lengths shall be taken from Table 15. The values in Table 15 are minimum lengths that are controlled by the geometry of the fittings and may need to be increased to provide sufficient length for over-wraps at the mitres and joints.

NOTE Dimensions other than those given in Table 15 can be used by agreement between the purchaser and the manufacturer.

Table 15 — Nominal body length, L_B , for bends

DN	Nominal fitting angle			
	α_n			
	90°	60°	45°	≤ 30°
Nominal body length ^a				
L_B mm				
150	230	135	95	65
200	440	390	390	380
250	710	400	380	380
300	690	380	380	380
400	720	630	255	380
500	1 000	630	610	380
600	1 000	610	590	380
700	1 030	620	590	380
800	1 590	620	590	380
900	1 590	880	600	380
1000	1 610	880	600	380

^a The nominal body length, L_B , equals the minimum body length.

6.2.2 Mechanical characteristics

Bends shall be designed and manufactured in accordance with relevant design practices to have a mechanical performance equal to or greater than that of a straight polyester resin concrete (PRC) pipe of the same nominal size, classification and strength class when installed in a piping system and, if appropriate, supported by anchor blocks or encasements.

The manufacturer of the bend shall document the fitting design and manufacturing procedure.

6.2.3 Leaktightness of installed bends

Where a specific site installation test is declared by the purchaser or agreed between the manufacturer and the purchaser, the bend and its joints shall be capable of withstanding that test following installation in the works.

When carrying out such tests, care should be taken to ensure that bends are fully restrained to prevent movement.

6.3 Branches

6.3.1 Geometrical characteristics

6.3.1.1 General

The dimensions measured in accordance with 4.3.4 shall conform to the applicable values and tolerances according to 6.3.1.2 to 6.3.1.4. The dimensions e , d_a and L_i and their tolerances shall be specified by the manufacturer in writing at the time of enquiry or delivery.

6.3.1.2 Diameter

The tolerance on the diameter of the main pipe or branch at the spigot positions shall conform to the applicable requirements in 5.3.

6.3.1.3 Nominal fitting angle

The nominal fitting angle, α_n (see Figure 9), shall, in the interests of rationalization, be one of the preferred values, either 45° or 90°. The deviation of the actual change in direction of a branch from the designated fitting angle shall not exceed 1° of the specified angle.

NOTE Fitting angles other than these can be supplied by agreement between the purchaser and the manufacturer.

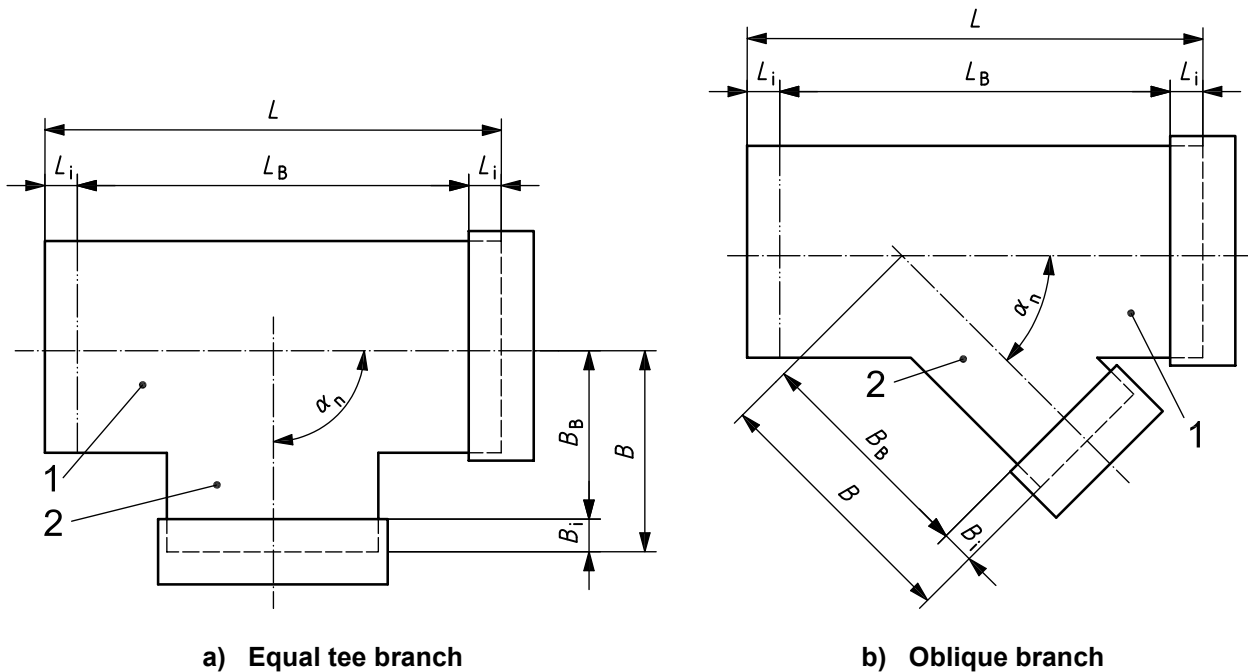

Key

- | | |
|---|--|
| α_n fitting angle | B_i insertion depth of the spigot of branch pipe |
| 1 main pipe | L laying length of main pipe |
| 2 branch pipe | L_B nominal body length of main pipe |
| B laying length of branch pipe | L_i insertion depth of main pipe spigot |
| B_B nominal offset body length of branch pipe | |

Figure 9 — Typical branches

6.3.1.4 Length

6.3.1.4.1 General

Only tee branches are covered by dimensional requirements in this part of ISO 18672.

NOTE Dimensions other than those specified can be used by agreement between the purchaser and the manufacturer.

6.3.1.4.2 Laying length

For a main pipe of a branch fitting, the laying length, L , is the body length, L_B , plus two spigot insertion depths of the joint, L_i (see Figure 9).

The laying length of the branch pipe, B (see Figure 9), is the distance from the end of the branch pipe excluding, where applicable, the spigot insertion depth of a socket end, to the point of intersection of the straight-through axis of the main pipe of the fitting with the extended axis of the branch pipe. The laying length, B , of the branch pipe of equal tee branch fittings shall be 50 % of the main pipe body length, L_B .

6.3.1.4.3 Body length

The nominal body length, L_B (see Figure 9), of the main pipe of a branch fitting is equal to the laying length, L , minus two spigot insertion depths, L_i .

For equal tees, the minimum nominal body length, L_B , shall be as follows:

- a) 500 mm for DN or WN \leq 200;
- b) 1 000 mm for DN or WN $>$ 200 and DN or WN \leq 600;
- c) 1 500 mm for DN or WN $>$ 600 and DN or WN \leq 1000.

6.3.1.4.4 Offset length

The nominal offset length, B_B (see Figure 9), of the branch pipe of a branch fitting is equal to the laying length, B , minus a spigot insertion depth, B_i .

6.3.1.4.5 Tolerances on length

The permissible deviations on the manufacturer's declared laying lengths, L and B , of the fitting shall be ± 25 mm or ± 1 % of the applicable laying length, whichever is the larger.

6.3.2 Mechanical characteristics

Branches shall be designed and manufactured in accordance with relevant design practices to have a mechanical performance equal to or greater than that of a straight polyester resin concrete (PRC) pipe of the same nominal size, classification and strength class when installed in a piping system, and, if appropriate, supported by anchor blocks or encasements.

The manufacturer of the branch shall document the fitting design and manufacturing procedure.

6.3.3 Leaktightness of installed branches

Where a specific site installation test is requested by the purchaser or is agreed between the manufacturer and the purchaser, the branch and its joints shall be capable of withstanding that test following installation in the works.

When carrying out such tests, care should be taken to ensure that branches are fully restrained to prevent movement.

6.4 Marking of fittings

Marking details shall be printed or formed directly on the fitting in such a way that the marking does not initiate cracks or other types of failure. If printing is used, the colouring of the printed information shall differ from the basic colouring of the product and such that the markings shall be readable without magnification.

The following marking shall be on the outside of each fitting:

- a) the number of this part of ISO 18672, i.e. ISO 18672-1;
- b) the designation with respect to the classification, i.e. PRC-OC, PRC-OE or PRC-OK;
- c) the nominal size, DN or WN/HN;
- d) the strength class, S_C ;
- e) the laying length(s);
- f) the fitting angle, α_f ;
- g) the radius of curvature, r , if applicable;
- h) the manufacturer's name or identification;
- i) the date or code of manufacture;
- j) quality mark, if applicable.

7 Joint performance

7.1 General

NOTE Interchangeability between products from different suppliers can only be achieved with appropriate regard to the pipe and joint dimensions.

7.1.1 Materials

Materials used in joint assemblies shall be in accordance with the pipe and fitting manufacturer's declared specification.

7.1.2 Dimensions

All dimensions of the tested joints that may influence the performance of the joint shall be recorded.

7.2 Requirements

7.2.1 General

A joint made between pipes conforming to Clause 5 and/or fittings conforming to Clause 6 shall be designed so that its leaktightness performance is equal to or better than the requirements of the piping system, but not necessarily of the components being joined.

For a particular design of joint, the properties described in 7.2.2 and 7.2.3, shall be declared by the manufacturer in writing at the time of enquiry or delivery.

7.2.2 Draw

Flexible joints shall be capable of conforming to 7.2.4 when a draw, D (see Figure 1), including temperature effects, of not less than 0,2 % of the laying length of the longest pipe with which the joint is intended to be used or the manufacturer's declared maximum draw, D_{\max} (see 4.4.2.2), whichever is greater, is applied.

7.2.3 Angular deflection

Flexible joints shall be capable of conforming to 7.2.4 when an angular deflection, δ (see Figure 1), not less than the manufacturer's declared maximum values is applied.

7.2.4 Leaktightness

7.2.4.1 Leaktightness when subjected to internal pressure following assembly

When assembled in accordance with the pipe manufacturer's recommendations, the joint shall withstand, without leakage, an internal pressure of 0,75 bar (75 kPa) for 15 min and shall subsequently conform to 7.2.4.2 and 7.2.4.3.

7.2.4.2 Leaktightness when simultaneously subjected to misalignment and draw

When the joint is subjected to the manufacturer's declared maximum draw, D_{\max} (see 7.2.2), and a total shear load, N_d , of 25 N/mm of the nominal size, DN or WN, in millimetres, it shall not show any visible sign of damage to its components nor leak when tested by the appropriate method given in ISO 8639 at the pressure and duration given in Table 16.

7.2.4.3 Leaktightness when simultaneously subjected to angular deflection and draw

When the joint is subjected to an angular deflection in accordance with 7.2.3 and a total draw, D_{tot} , equal to the manufacturer's maximum draw, D_{\max} (see 7.2.2), plus the longitudinal movement, J (see Figure 1), resulting from the applied angular deflection, it shall not show any visible signs of damage to its components nor leak when tested by the appropriate method given in ISO 8639 at the pressure and duration given in Table 16.

7.2.4.4 Resistance to an external pressure differential

7.2.4.4.1 General

The assessment of a joint's ability to resist external water pressure shall be made using either internal negative pressure or external water pressure.

7.2.4.4.2 Leaktightness test when subjected to negative pressure

When the joint is subjected to the declared maximum draw, D_{\max} (see 7.2.2) it shall not show any visible signs of damage to its components nor exhibit a change in pressure greater than 0,08 bar/h (0,008 MPa/h) when tested by the appropriate method given in ISO 8639 at the pressure and duration given in Table 16.

7.2.4.4.3 Leaktightness test when subjected to external water pressure

When the joint is subjected to the declared maximum draw, D_{\max} (see 7.2.2), it shall not show any visible signs of damage to its components nor leak when tested using a test arrangement such as shown in Figure 10 at the pressure and duration given in Table 16.

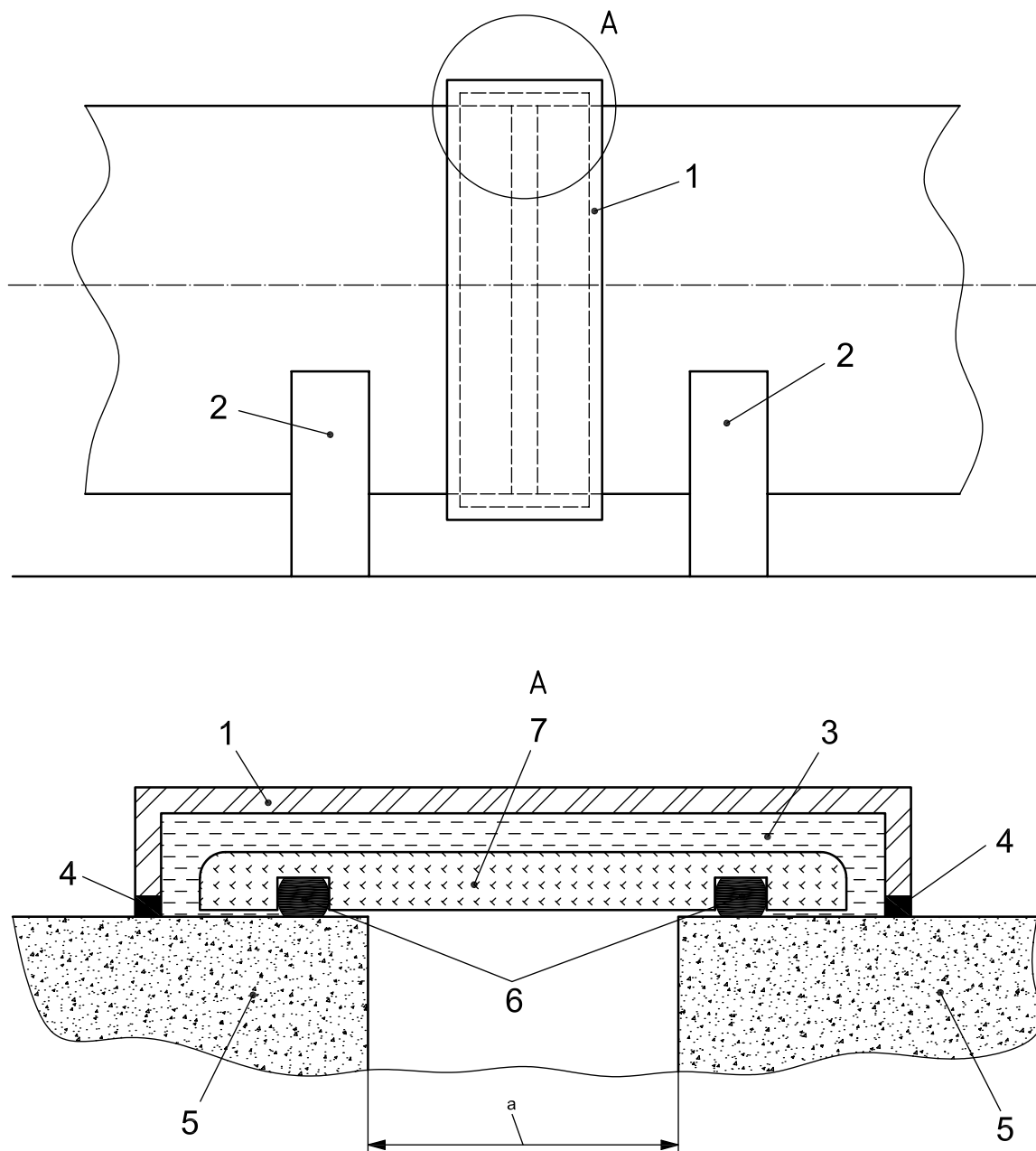

Key

- | | |
|------------------------|----------------------|
| 1 metal jacket | 5 pipe wall |
| 2 support for pipe | 6 joint seal |
| 3 water under pressure | 7 joint being tested |
| 4 watertight seal | |

a Distance between pipe ends.

Figure 10 — Typical test arrangement for resistance to an external pressure differential using external water pressure

7.2.4.5 Number of test pieces

The number of joint assemblies to be tested for each test in 7.2.4 shall be one.

It is permitted to use the same assembly for more than one test.

7.2.4.6 Test pieces

A test piece shall comprise a joint and two pieces of pipe such that the total length of the test piece, l_p , is not less than is required to meet the requirements of the test method.

Table 16 — Summary of test requirements for flexible joints

Joint position	Tests	Test pressure bar	Duration
Initial leakage	Initial pressure	0,75 ^a	15 min
Misalignment and draw	Positive static pressure	1	24 h
Angular deflection and draw	Initial pressure	0,75	15 min
	Positive static pressure	1	24 h
External pressure differential	Using negative pressure	-0,8 bar (-0,08 MPa)	1 h
	Using external water pressure	1	1 h
^a Relative to atmospheric, i.e. approximately 0,75 bar (0,075 MPa) absolute.			

Annex A (normative)

Test method for the determination of a pipe's crushing strength and ring bending tensile strength using a pipe test piece

A.1 General

This test determines the capacity of a pipe to resist an external load perpendicular to its axis along its length. The test is applicable to pipes of any nominal size having a circular, egg-shaped or kite-shaped cross-section

According to 5.4.1, this test may be carried out on sawn test pieces in accordance with Annex B if a suitable apparatus is not available.

A.2 Principle

This test is used to show compliance with the minimum requirements for the crushing strength specified in 5.4.1 or to determine the ring bending tensile strength of polyester resin concrete (PRC) used to make a pipe. A test piece is subjected to a vertical load across its diameter for the whole of its length. To show compliance with the minimum crushing strength the load applied is the minimum crushing load, $q_{cr,min}$, specified in 5.4.1, times the length of the test piece. When it is required to determine the crushing strength of a pipe or the ring bending tensile strength of its polyester resin concrete (PRC), the load applied is increased until the test piece fails. Using the load applied, the length of the test piece and the applicable equations in this annex, the minimum strengths are confirmed or the actual strengths are determined.

A.3 Apparatus

A.3.1 Loading frame, capable of applying a compressive load to the test piece, which shall be a whole pipe or a pipe section having a length not less than that given in 5.4.1.2, at a steady rate between 400 N/s and 600 N/s until either the specified minimum crushing load is reached or the test piece fails.

The machine shall be sufficiently rigid so that the distribution of the load will not be affected by the deformation or yielding of any part and shall transmit the load, without shock, in a vertical plane through the longitudinal centre lines of the bearers and the test piece.

The load shall be applied in such a way that the combination of support and bearers is free to rotate in a vertical plane through the longitudinal centre lines of the top and bottom bearers.

The machine shall be equipped with a means of measuring, indicating and recording the total load applied to the test piece to an accuracy of within $\pm 2\%$ of the load applied.

A.3.2 Bearers, made of metal or suitable hardwood, which is straight and free of warping, twisting or knots. They may be continuous or segmented.

The bearers shall have a thickness that is not less than 25 mm and shall be placed centrally on their supports. They shall be positioned centrally below the axis of load application and parallel to the pipe's longitudinal axis.

The load shall be applied through one top bearing strip.

For pipes with an external circular shape, the bottom bearer shall be formed as a V-shaped support, with the slope of the surface between 0° and 15° , and shall have a width not less than that required to support the test

piece, or it shall consist of two bearing strips placed with their centres at a distance which subtends an angle of 30° at the centre of the pipe (see Figure A.1).

Pipes with a base shall be supported by two bearing strips placed with their centres at a distance equal to 0,3 times the internal diameter, d_i , or width, w_i , as appropriate to the shape of the bore (see Figure A.2).

The surfaces that are in contact with the test piece shall be in the form either of facings or of strips, as shown in Figure A.1 or A.2. They shall be of an elastomeric material having a hardness of 55 ± 10 IRHD or, in the case of facings made of felt, they shall have a density of $(0,3 \pm 0,025)$ grams/cm³ and shall have a thickness of (20 ± 5) mm.

The width of a bearing strip, a_b , shall be not less than the width of its corresponding contact surface to the test piece but not greater than the applicable value in Table A.1.

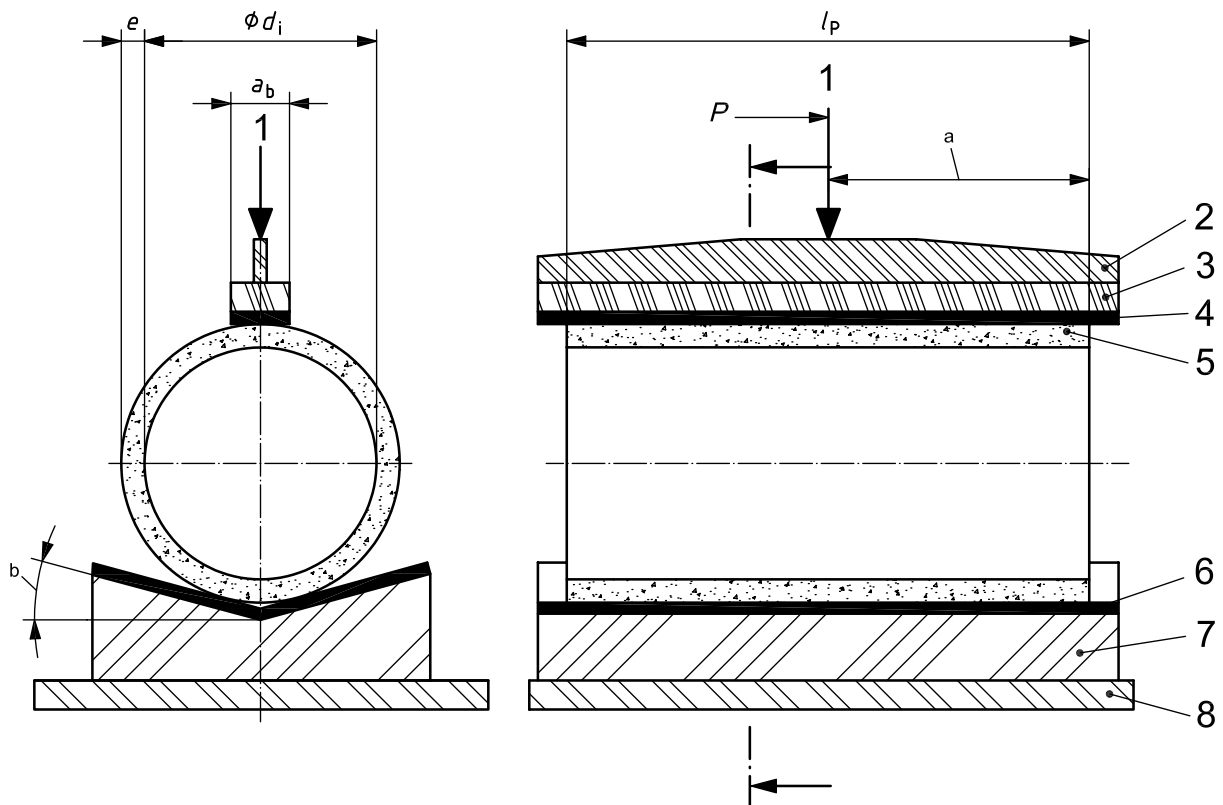

a) Plain pipe

Figure A.1 (continued)

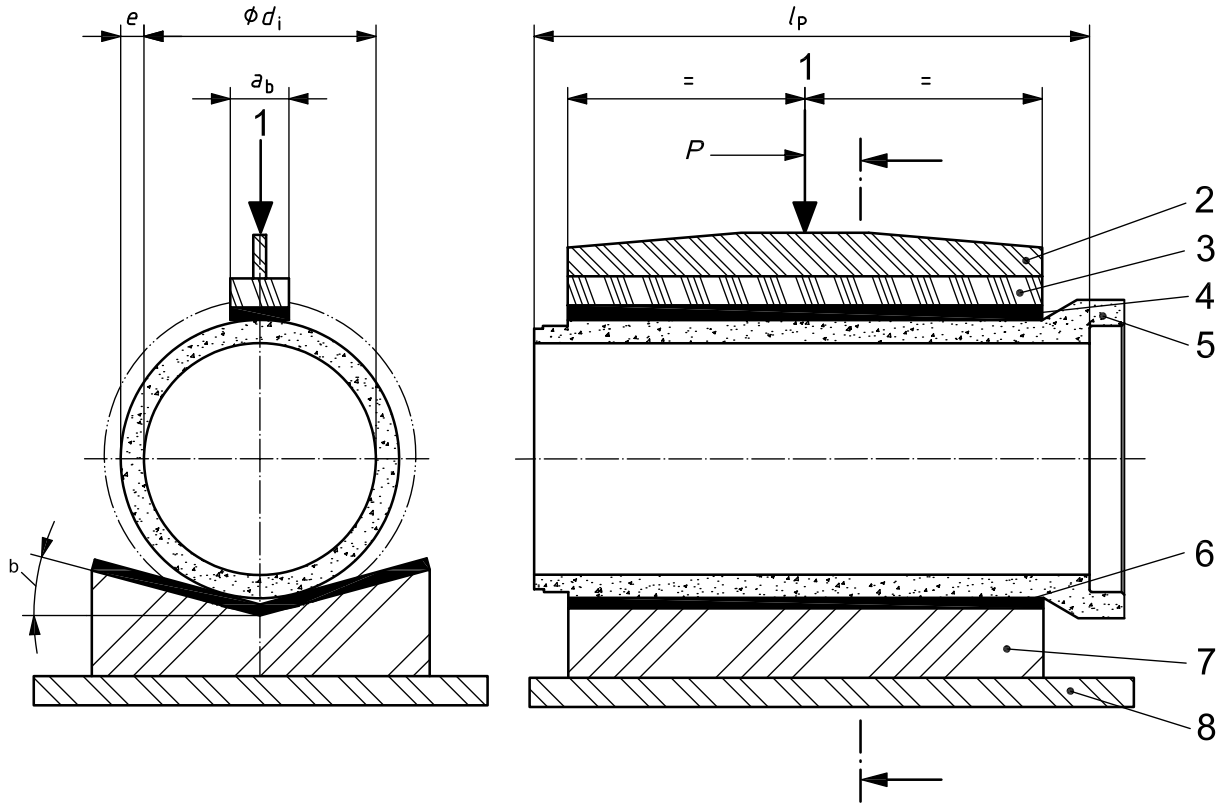

b) Pipe with integral socket

Key

- | | | | |
|---|---|-------|---------------------------------|
| 1 | axis of load application | a_b | width of the bearing strip |
| 2 | compression edge | d_i | internal diameter of test piece |
| 3 | compression beam | e | wall thickness of test piece |
| 4 | elastomeric or felt facing top bearing strip | l_p | length of test piece |
| 5 | polyester resin concrete (PRC) test piece | P | applied load |
| 6 | elastomeric or felt facing bottom bearing strip | | |
| 7 | metal or knotless hardwood bearer | | |
| 8 | testing machine base plate | | |
- a $0,5 \times l_p$.
- b Angle of bearer surface, 0° to 15° .

Figure A.1 — Typical arrangement for the crushing strength test on pipes with an external circular shape

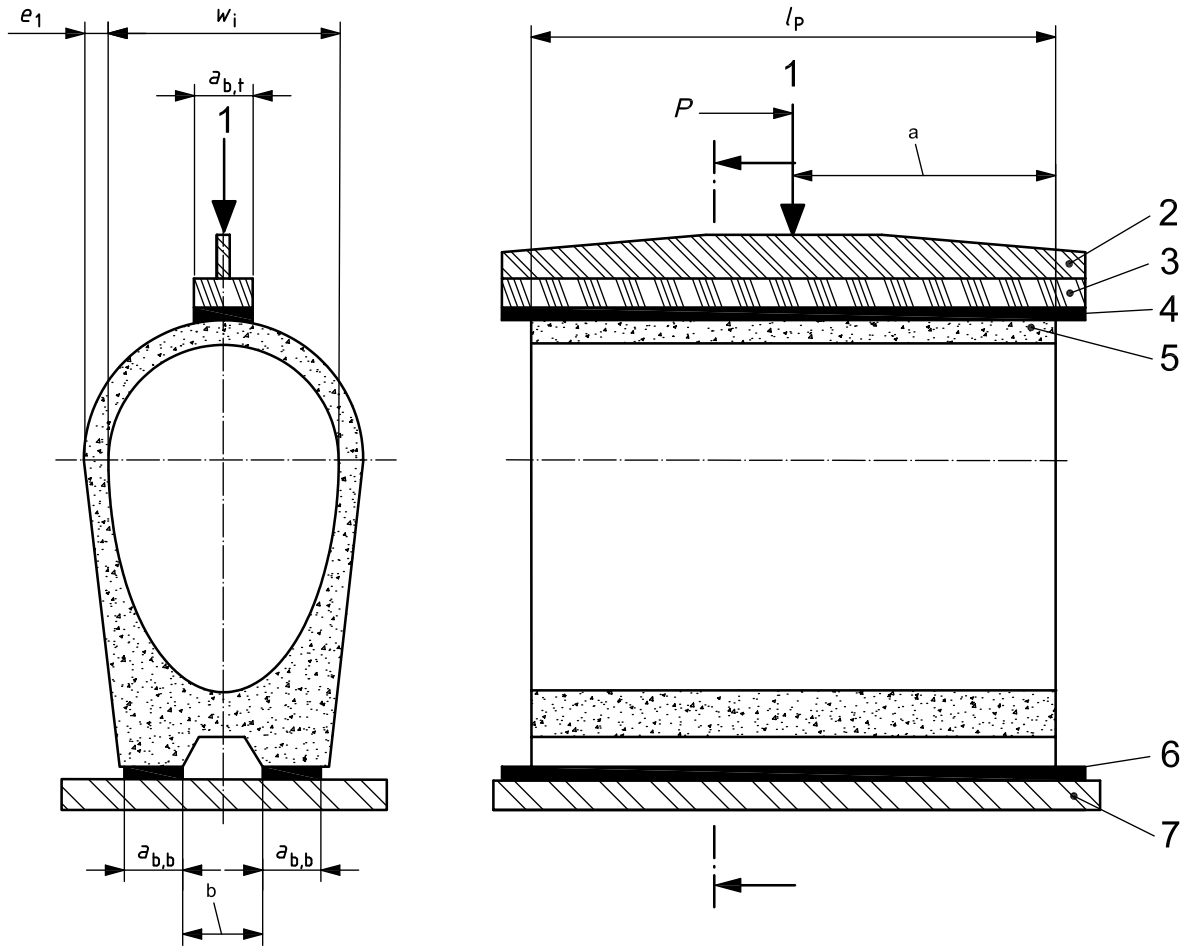

Key

- | | | | |
|---|--|-----------|-----------------------------------|
| 1 | axis of load application | $a_{b,t}$ | width of the top bearing strip |
| 2 | compression edge | $a_{b,b}$ | width of the bottom bearing strip |
| 3 | compression beam | e_1 | wall thickness of test piece |
| 4 | elastomeric or felt facing top bearing strip | l_p | length of test piece |
| 5 | polyester resin concrete (PRC) test piece | P | applied load |
| 6 | elastomeric or felt facing bottom bearing strips | w_i | internal width of test piece |
| 7 | testing machine base plate | | |
- a $0,5 \times l_p$.
- b Distance $0,3 \times w_i$.

Figure A.2 — Typical arrangement for the crushing strength test on pipes with a base

Table A.1 — Maximum width of bearing strips

Pipe nominal size DN or WN	Maximum width of bearing strips a_b mm
$(DN \text{ or } WN) \leq 400$	50
$400 < (DN \text{ or } WN) \leq 1200$	100
$1200 < (DN \text{ or } WN) \leq 2500$	150
$2500 < (DN \text{ or } WN)$	200

A.4 Test pieces

Three test pieces of the same size and classification shall be used.

The test piece shall be a whole pipe or a whole cross-section of pipe having a length not less than that given in 5.4.1.2. The ends of the test piece shall be cut plane and perpendicular to the pipe axis.

A.5 Procedure

NOTE When testing a whole pipe, the laying length is used as the length of the test piece for the calculation of loads and properties.

Place the test piece horizontally and centrally on the bottom bearer.

When testing to check conformity with the minimum crushing strength requirement, calculate the minimum test load in accordance with A.6, by multiplying the minimum crushing load, $q_{cr,min}$, in newtons (N), specified in 5.4.1, by the length of the test piece in millimetres (mm).

Apply the load to the test piece continuously, at a rate of between 400 N/s and 600 N/s, until either the required test load, P_{min} (taking into account the load due to the weight of the compression beam, W^*) is reached or failure occurs.

If failure occurs, calculate the crushing strength of the pipe and ring bending tensile strength of its polyester resin concrete (PRC) in accordance with A.6, and record the results.

Record the test load applied and the appearance and dimensions of the test piece.

A.6 Calculations

A.6.1 Crushing strength

Calculate the minimum test load, P_{calc} , in newtons (N), using Equation (A.1) and the load to be applied using Equation (A.2) as follows:

$$P_{calc} = q_{cr,min} \times l_p \quad (A.1)$$

where

l_p is the length of the test piece, in millimetres;

$q_{cr,min}$ is the minimum crushing load, in newtons per millimetre length.

The minimum crushing load is calculated using Equation (1) or (2) as given in 3.1.11, as applicable:

$$q_{cr,min} = S_c \times [DN] \times 0,001 \quad (1)$$

$$q_{cr,min} = S_c \times [WN] \times 0,001 \quad (2)$$

where

S_c is the strength class given in Table A.2, A.3 or A.4, as applicable, for the nominal size of the pipe under consideration, in newtons per millimetre length (N/mm);

[DN] or [WN] is the applicable nominal internal size for the pipe under consideration, taken as a dimensionless value.

The minimum load, P_{\min} , in newtons (N), to be applied is given by Equation (A.2):

$$P_{\min} = P_{\text{calc}} - W^* \quad (\text{A.2})$$

where

P_{calc} is the calculated minimum test load, in newtons;

W^* is the load due to the weight of the compression beam and, if applicable, of the compression edge, in newtons.

Table A.2 — Minimum strength classes for pipes designated PRC-OC or PRC-TC

Nominal size DN	Strength class S_c N/mm	
	PRC-OC	PRC-TC
$150 \leq \text{DN} \leq 500$	140	160
$600 \leq \text{DN} \leq 1000$	120	140
$1200 \leq \text{DN} \leq 3000$	90	120

Table A.3 — Minimum strength classes for pipes designated PRC-OE or PRC-TE

Nominal width/height WN/HN	Strength class S_c N/mm	
	PRC-OE	PRC-TE
$300/450 \leq \text{DN} \leq 600/900$	140	160
$700/1050 \leq \text{DN} \leq 1000/1500$	120	140
$1200/1800 \leq \text{DN} \leq 1400/2100$	90	120

Table A.4 — Minimum strength classes for pipes designated PRC-OK or PRC-TK

Nominal size DN	Strength class S_c N/mm	
	PRC-OK	PRC-TK
$800 \leq \text{DN} \leq 1000$	120	140
$1200 \leq \text{DN} \leq 1800$	90	120

If failure occurs before the minimum load, P_{\min} , is reached or the load applied is increased until failure occurs, then calculate the crushing strength, q_{cr} , in newtons per millimetre of length (N/mm), using Equation (A.3):

$$q_{\text{cr}} = \frac{P_{\text{cr}} + W^*}{l_p} \quad (\text{A.3})$$

where

- P_{cr} is the load applied by the loading frame at failure, in newtons;
- W^* is the load due to the weight of the compression beam and, if applicable, of the compression edge, in newtons;
- l_p is the length of the test piece, in millimetres.

A.6.2 Ring bending tensile strength of polyester resin concrete (PRC)

If the ring bending tensile strength of polyester resin concrete (PRC), σ_{rb} , is required for calculation purposes, then its value can be determined using Equations (A.4) to (A.7), as applicable.

NOTE If failure occurs, then the calculated ring bending tensile stress determined using Equation (A.4) or (A.6) is termed the ring bending tensile strength, σ_{rb} , in newtons per square millimetre (N/mm²). If failure does not occur, then the determined value is the ring bending tensile stress, σ_{rb} , in newtons per square millimetre (N/mm²).

A.6.2.1 For pipes with a circular or kite-shaped cross-section, i.e. types PRC-OC, PRC-TC, PRC-OK or PRC-TK:

$$\sigma_{rb} = \frac{P_{\text{eff,CK}}}{l_p} \times \frac{3 \times d_i + 5 \times e}{e^2} \quad (\text{A.4})$$

where

- d_i is the internal diameter of the test piece, in millimetres;
- e is the wall thickness of a test piece having a circular or kite-shaped cross-section, in millimetres;
- l_p is the length of the test piece, in millimetres;
- $P_{\text{eff,CK}}$ is the effective test load applied to test pieces with circular or kite-shaped cross-section, in newtons.

The effective test load applied to test pieces with circular or kite-shaped cross-section is calculated using Equation (A.5):

$$P_{\text{eff,CK}} = 0,07 \times W_p + 0,3 \times (P + W^*) \quad (\text{A.5})$$

where

- W_p is the load due to the weight of the test piece, in newtons;
- P is the load applied, in newtons;
- W^* is the load due to the weight of the compression beam and, if applicable, of the compression edge, in newtons (N).

A.6.2.2 For pipes with an egg-shaped cross-section, i.e. types PRC-OE or PRC-TE:

$$\sigma_{rb} = \frac{P_{\text{eff,E}}}{l_p} \times \frac{3 \times w_i + 5 \times e_2}{e_2^2} \quad (\text{A.6})$$

where

- w_i is the horizontal internal width of the test piece, in millimetres;
- e_2 is the wall thickness of the test piece at the top of a pipe having an egg-shaped cross-section, in millimetres;
- l_p is the length of the test piece, in millimetres;
- $P_{\text{eff,E}}$ is the effective test load applied to test pieces with egg-shaped cross-section, in newtons. It is calculated using Equation (A.7):

$$P_{\text{eff,E}} = 0,06 \times W_p + 0,35 \times (P + W^*) \quad (\text{A.7})$$

where

- W_p is the load due to the weight of the test piece, in newtons;
- P is the applied load, in newtons;
- W^* is the load due to the weight of the compression beam and, if applicable, of the compression edge, in newtons.

A.7 Test report

The test report shall include the following information:

- a) a reference to this part of ISO 18672 and this annex, i.e. ISO 18672-1:2009, Annex A;
- b) full identification of the pipe tested, including the cross-sectional shape, i.e. C, E or K;
- c) the number of test pieces;
- d) the dimensions of each test piece;
- e) the date, time and place of testing;
- f) for each test piece, whether or not it failed;
- g) for each test piece subjected to the minimum strength test, the actual load, P , and the minimum load for compliance, P_{min} ;
- h) the load due to the weight of the compression beam and, if applicable, of the compression edge, W^* ;
- i) for each test piece, the calculated value for minimum crushing load, $q_{\text{cr,min}}$, or the actual crushing strength, q_{cr} , as applicable;
- j) for each test piece, the load due to the weight of the test piece, W_p , if applicable;
- k) for each test piece, the calculated value of the ring bending tensile stress or strength, σ_{rb} , if applicable;
- l) equipment details;
- m) the temperature during the test;
- n) a description of the test pieces after testing;
- o) any factors not specified in this part of ISO 18672 which may have affected the results, such as incidents or operating details.

Annex B (normative)

Test method for the determination of a pipe's crushing strength or ring bending tensile strength using test pieces sawn from a pipe

B.1 General

This annex gives a method for the determination of the capacity of a pipe to resist an external load perpendicular to its axis along its length, using test pieces sawn from a pipe. The method is applicable to pipes having a circular, egg-shaped or kite-shaped cross-section of any nominal size. The method may be used instead of the crushing strength test described in Annex A if the apparatus described in Annex A is not available.

B.2 Principle

This test determines the ring bending tensile strength, σ_{rb} , or crushing strength of a polyester resin concrete (PRC) pipe using test pieces cut from a pipe, rather than lengths of pipe as used in Annex A, to determine the same properties. These properties are used to assess the capacity of the pipe to resist an external load along its length.

B.3 Apparatus

B.3.1 Loading frame, capable of applying a compressive load to the test piece without shock or impact, until either the required minimum ring bending tensile strength is reached or the test piece is taken to failure. The load shall be applied at a steady rate so that the required load is reached within 2 min to 3 min.

The machine shall be sufficiently rigid that the distribution of the load is not affected by the deformation or yielding of any part and shall transmit the load in a vertical plane through the longitudinal centre lines of the test piece.

The load shall be applied in such a way that the combination of support and bearers is free to rotate in a vertical plane through the longitudinal centre lines of the top and bottom bearers.

Free movement of one of the bottom bearing beams shall be ensured.

The machine shall be equipped with a means of measuring, indicating and recording the total load applied to the test piece to an accuracy of within $\pm 2\%$ of the load applied.

B.3.2 Bearers and contact surfaces.

The bearers shall be made of metal or a suitable hardwood, which is straight and free of warping, twisting or knots.

The bearers shall have a thickness that is not less than 25 mm.

The load shall be applied through the top bearing strip.

The surfaces that are in contact with the test piece shall be in the form of facings to the beams (see Figure B.1). They shall either be of an elastomeric material, having a hardness of (55 ± 10) IRHD or of felt having a density of $(0,3 \pm 0,025)$ g/cm³. The facing of the top bearer shall have a thickness of 3 mm, and the bottom bearing beam's facing shall have a thickness of (20 ± 5) mm.

The width of the top bearing strip, a_b , shall be 1/10 of the spacing between the centres of the bearing beams, l_b (see Figure B.1).

The bottom bearing beams shall be located centrally about the axis of load application on the bottom bearer.

Free movement of one of the bottom bearers shall be ensured.

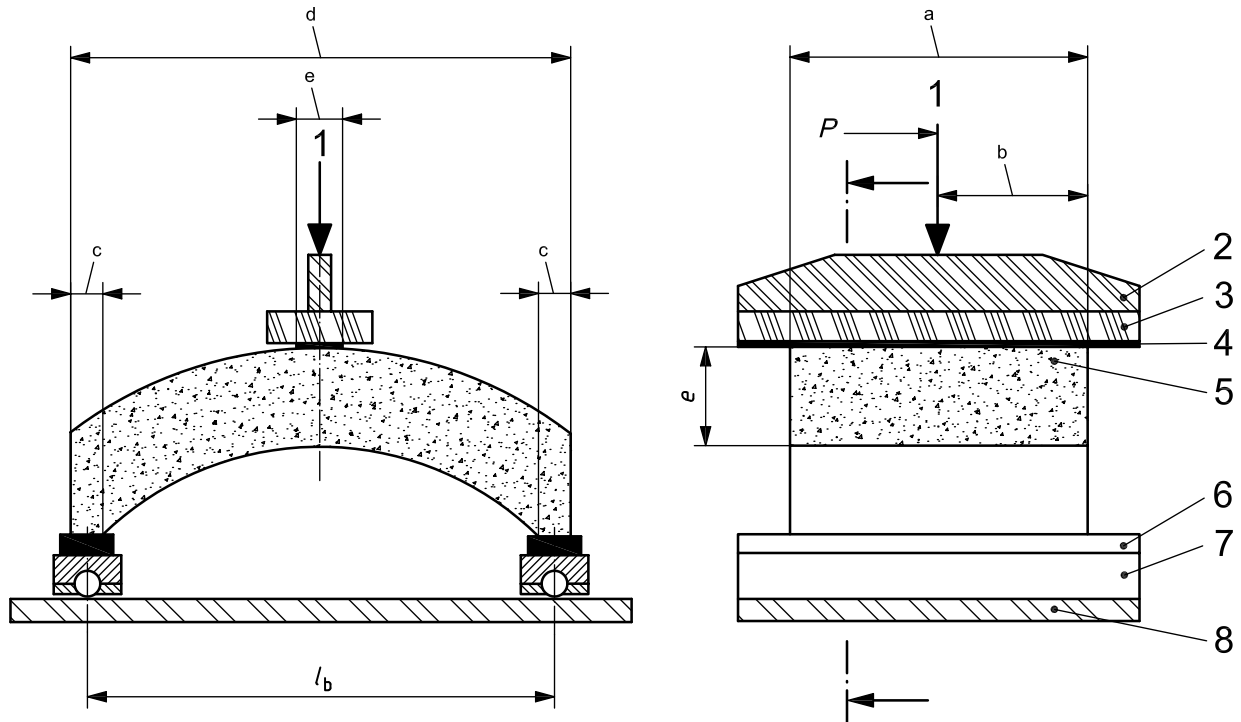

Key

- | | | | |
|---|---|-------|---|
| 1 | axis of load application | 7 | metal roller bearer to provide movement |
| 2 | compression edge | 8 | test machine base plate |
| 3 | compression beam | e | wall thickness of test piece |
| 4 | elastomeric or felt facing 3 mm thick | l_b | distance between bearers |
| 5 | polyester resin concrete (PRC) test piece | P | applied load |
| 6 | elastomeric or felt facing 20 mm thick | | |
-
- | | |
|---|--|
| a | Width of the test piece, $b = 3 \times e$. |
| b | Location of applied load, $0,5 \times b$. |
| c | Width of the ground surface, $0,33 \times e$. |
| d | Length of test piece, $l_p = 5 \times e$. |
| e | Width of the top bearing strip, $a_b = 0,1 \times l_b$. |

Figure B.1 — Test arrangement when using test pieces taken from a pipe

B.4 Test piece

The test piece shall be sawn from a pipe or a broken piece of a pipe. When testing pipes with kite-shaped or egg-shaped cross-section, the test pieces shall be taken from the top of the pipe.

The test piece shall have parallel boundary surfaces and its length, l_p , shall be about 5 times the wall thickness, e , and its width, b , about 3 times the wall thickness.

NOTE The dimensions quoted are indicative only.

The longitudinal sides of the test piece shall be perpendicular to the generated surface of the pipe.

B.5 Test procedure

B.5.1 Determination of minimum test load to be applied

B.5.1.1 To verify conformity with the pipe's specified minimum crushing strength, perform the calculations in this clause to determine the test load to be applied, P_{\min} .

To determine the crushing strength of a pipe or the ring bending tensile strength of its polyester resin concrete (PRC), proceed as described in B.5.2. Otherwise, proceed with the applicable calculations in this clause.

B.5.1.2 Calculate the minimum crushing load, $q_{cr,\min}$, in newtons per millimetre of pipe length (N/mm), using Equation (1) or (2), as applicable:

$$q_{cr,\min} = S_c \times [\text{DN}] \times 0,001 \quad (1)$$

$$q_{cr,\min} = S_c \times [\text{WN}] \times 0,001 \quad (2)$$

where

S_c is the strength class given in Table A.2, A.3 or A.4, as applicable, for the nominal size of the pipe under consideration, in newtons per millimetre length (N/mm);

[DN] or [WN] is the applicable nominal internal size for the pipe under consideration, taken as a dimensionless value.

B.5.1.3 Calculate the minimum ring bending tensile stress, $\sigma_{rb,\min}$, in newtons per square millimetre (N/mm²), for circular and kite-shaped pipes, using Equation (B.1) or, for egg-shaped pipes, using Equation (B.2):

$$\sigma_{rb,\min} = \frac{(q_{cr,\min} + 7/30 \times W_{\text{pipe}}) \times 0,3 (3 \times d_i + 5 \times e)}{e^2} \quad (B.1)$$

$$\sigma_{rb,\min} = \frac{(q_{cr,\min} + 6/35 \times W_{\text{pipe}}) \times 0,35 (3 \times w_i + 5 \times e_2)}{e_2^2} \quad (B.2)$$

where

$q_{cr,\min}$ is the minimum crushing load, in newtons per millimetre of pipe length;

d_i is the internal diameter of the pipe, in millimetres;

e is the wall thickness of the pipe, in millimetres;

- e_2 is the wall thickness at the top of an egg-shaped cross-section pipe, in millimetres;
- w_i is the horizontal internal width of a pipe with egg-shaped cross-section, in millimetres;
- W_{pipe} is the load due to the weight of the pipe, in newtons per millimetre of pipe length.

B.5.1.4 To verify conformity with the minimum crushing strength for a pipe, calculate the minimum test load, P_{calc} , in newtons (N), for the applicable shape of pipe, using Equation (B.3) and the load to be applied by the loading frame to the test piece, P_{min} , in newtons (N), using Equation (B.4):

$$P_{\text{calc}} = \frac{\sigma_{\text{rb,min}} \times 2 \times b \times e^2}{3 \times l_b \times f_{\text{corr}}} \quad (\text{B.3})$$

$$P_{\text{min}} = P_{\text{calc}} - W^* \quad (\text{B.4})$$

where

- W^* is the load due to the weight of the compression beam and, if applicable, of the compression edge, in newtons;
- $\sigma_{\text{rb,min}}$ is the minimum ring bending tensile stress obtained from Equation (B.1) or (B.2) as applicable, in newtons per square millimetre;
- b is the width of the test piece, in millimetres;
- e is the wall thickness of the test piece, in millimetres;
- l_b is the distance between bearers, in millimetres;
- f_{corr} is the correction factor to allow for stress distribution in the curved beam, derived from Equation (B.5a) or (B.5b), as applicable:

$$f_{\text{corr}} = \frac{(3 \times d_i) + (5 \times e)}{(3 \times d_i) + (3 \times e)} \quad (\text{B.5a})$$

$$f_{\text{corr}} = \frac{(3 \times w_i) + (5 \times e)}{(3 \times w_i) + (3 \times e)} \quad (\text{B.5b})$$

where

- e is the wall thickness of the test piece, in millimetres;
- d_i is the internal diameter of the original pipe, in millimetres;
- w_i is the horizontal internal width of the original pipe with egg-shaped cross-section, in millimetres.

B.5.2 Load application

Place the test piece horizontally and centrally on the bottom bearing beams, as shown in Figure B.1.

When checking conformity with the minimum crushing strength, apply the load continuously at a steady rate so that either the required load, P_{min} , is reached within 2 min to 3 min or the test piece fails. Record the load applied and the appearance and dimensions of the test piece.

When determining the crushing strength, apply the load continuously at a steady rate so that failure occurs within 2 min to 3 min. Record the maximum load applied and the appearance and dimensions of the test piece.

B.6 Calculations

B.6.1 Ring bending tensile strength

If the maximum load applied during the test, P , causes the test piece to break, then the value of these calculations for σ_{rb} is the ring bending tensile strength of the pipe's polyester resin concrete (PRC). If however, the maximum load applied does not cause the test piece to break, then the calculated value for σ_{rb} is the ring bending tensile stress achieved during the test.

Calculate the ring bending tensile stress or strength of a pipe's polyester resin concrete (PRC), σ_{rb} , in newtons per square millimetre (N/mm²), using Equation (B.6):

$$\sigma_{rb} = \frac{3 \times P}{2 \times b} \times \frac{l_b}{e^2} \times f_{corr} \quad (\text{B.6})$$

where

f_{corr} is the correction factor to allow for the stress distribution in the curved beam, calculated using Equation (B.5a) or (B.5b) as applicable;

P is the maximum load applied during the test, including W^* , in newtons;

l_b is the spacing between the centres of the bearing beams, in millimetres;

b is the width of the test piece, in millimetres;

e is the wall thickness of the test piece, in millimetres.

B.6.2 Crushing strength

To assess conformity with the minimum crushing strength requirements, perform the following calculation to determine the crushing load, q_{cr} , in newtons per millimetre of length (N/mm), using the applicable Equation, (B.7a) or (B.7b), and the ring bending tensile stress, σ_{rb} , determined in accordance with B.6.1. If failure of the test piece occurred during the test, then use the ring bending tensile strength, σ_{rb} , determined in accordance with B.6.1, and the calculated value for q_{cr} is then the crushing strength of the original pipe.

B.6.2.1 Pipes with a circular or kite-shaped cross-section, i.e. types PRC-OC, PRC-TC, PRC-OK or PRC-TK

For pipes with a circular or kite-shaped cross-section, i.e. types PRC-OC, PRC-TC, PRC-OK or PRC-TK, use Equation (B.7a):

$$q_{cr} = \frac{\sigma_{rb}}{0,3} \times \frac{e^2}{3 \times d_i + 5 \times e} - \frac{7}{30} \times W_{pipe} \quad (\text{B.7a})$$

where

σ_{rb} is the ring bending tensile stress or strength determined in accordance with B.6.1, in newtons per square millimetre;

d_i is the internal diameter of the original pipe, in millimetres;

e is the wall thickness of the original pipe, in millimetres;

W_{pipe} is the load due to the weight of the pipe, in newtons per millimetre of pipe length.

B.6.2.2 Pipes with an egg-shaped cross-section, i.e. types PRC-OE or PRC-TE

For pipes with an egg-shaped cross-section, i.e. types PRC-OE or PRC-TE, use Equation (B.7b):

$$q_{cr} = \frac{\sigma_{rb}}{0,35} \times \frac{e^2}{3 \times w_i + 5 \times e_2} - \frac{6}{35} \times W_{pipe} \quad (\text{B.7b})$$

where

- σ_{rb} is the ring bending tensile stress or strength determined in accordance with B.6.1, in newtons per square millimetre;
- w_i is the internal width of the original pipe with egg-shaped cross-section, in millimetres;
- e_2 is the wall thickness of the original pipe at the top, in millimetres;
- W_{pipe} is the load due to the weight of the pipe, in newtons per millimetre of pipe length.

B.7 Test report

The test report shall include the following information:

- a) a reference to this part of ISO 18672 and this annex, i.e. ISO 18672-1:2009, Annex B;
- b) full identification of the pipe from which the test piece was obtained;
- c) the date, time and place of sampling;
- d) the number of test pieces made and tested and their identification numbers or codes;
- e) the dimensions of each test piece, if applicable, its mass and calculated density;
- f) the date, time and place of testing;
- g) for each test piece, whether it failed or not;
- h) for each test piece, the minimum load to be applied to the test piece by the loading frame, P_{min} , if applicable;
- i) for each test piece, the maximum load applied during the test, P , including W^* ;
- j) for each test piece, the value for σ_{rb} ;
- k) for each test piece, the calculated value for f_{corr} ;
- l) the distance between the centres of the bearing beams, l_b ;
- m) for each test piece, the calculated value for q_{cr} ;
- n) equipment details;
- o) the temperature during the test;
- p) a description of the test pieces after testing;
- q) any factors not specified in this part of ISO 18672 which may have affected the results, such as incidents or operating details.

Annex C (normative)

Test methods for the assessment of longitudinal bending moment resistance

C.1 General

This test determines the capacity of a pipe to resist bending along its length when external loads are applied. The test is applicable to pipes of any nominal size having an external circular shape and laying lengths greater than six times their (vertical) internal diameter. Two test procedures are specified using either a three-point or a four-point loading arrangement.

C.2 Principle

This test is used to show compliance with the minimum requirements for the longitudinal bending moment resistance (BMR) of a pipe, specified in 5.4.2, by subjecting the test piece to a bending moment, M_3 or M_4 , from either a three-point or a four-point loading arrangement. When testing using the three-point loading method, if the test piece fails in such a way as not to be “beam” failure (i.e. if crushing occurs at an end prior to the required test load being achieved), then the test shall be repeated using the four-point loading method.

C.3 Apparatus

C.3.1 Loading frame, capable of applying a specified load to the test piece, at a steady rate between 6 kN and 9 kN per minute, either through two loading slings, when using a four-point loading arrangement, or through a bearing block, when using a three-point loading arrangement. The apparatus shall be substantially rigid throughout, so that the distribution of the load is not affected appreciably by the deformation or yielding of any part, and shall transmit the load, without shock, to the test piece.

The machine shall be equipped with a means of measuring, indicating and recording the total load applied to the test piece to an accuracy of within $\pm 2\%$ of the load applied.

C.3.2 Supports, arranged as shown in Figure C.1 or C.2, as applicable.

C.3.2.1 Slings, having a width of 100 mm and of sufficient strength for the application of the load through slings when the four-point loading method is used. The slings shall be so designed that there is a contact angle of at least 120° around the test piece's circumference.

C.3.2.2 Bearing blocks, of sufficient strength, and having a length of approximately $1,5 \times DN$ and a width of (75 ± 5) mm, for the application of the load through blocks when the three-point loading method is used. The block surface intended to be in contact with the test piece through at least 120° of its circumference shall match the test piece curvature and shall be lined with an elastomeric material having an IRHD of (55 ± 5) and a thickness of (20 ± 5) mm.

Dimensions in millimetres

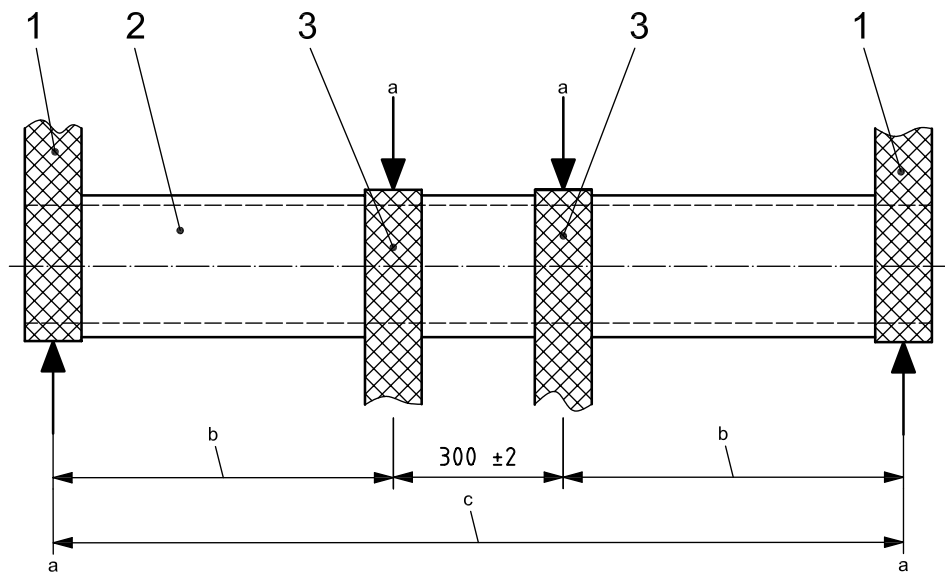

a) Test arrangement for a plain pipe

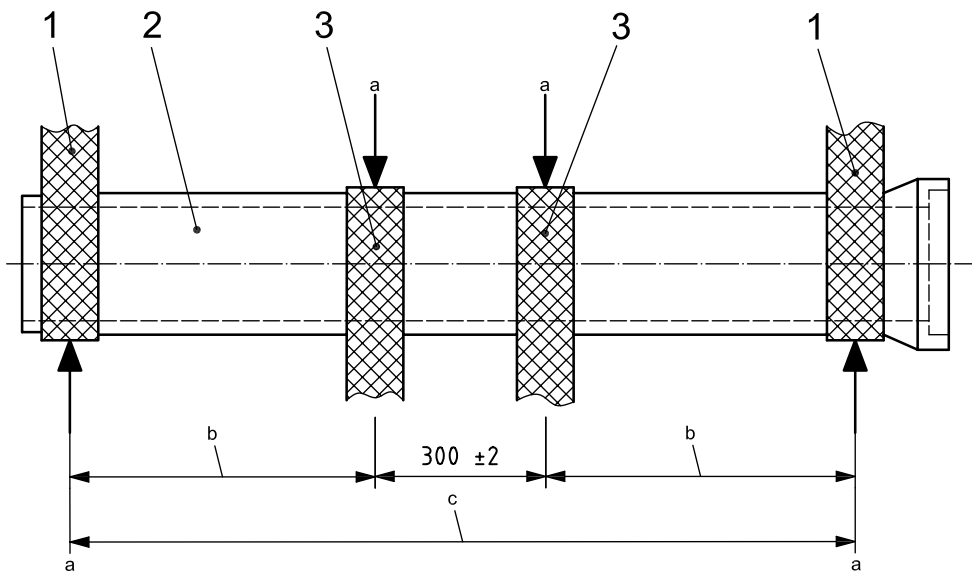

b) Test arrangement for a pipe with an integral socket

Key

- 1 supporting sling
- 2 polyester resin concrete (PRC) test piece
- 3 loading sling

- a Half the applied bending load, $0,5 \times P_b$.
- b Lever arm, l_a , 300 mm minimum.
- c Supporting span, l_s , minimum $[(6 \times DN) - 100]$ mm.

Figure C.1 — Arrangement for the four-point loading method

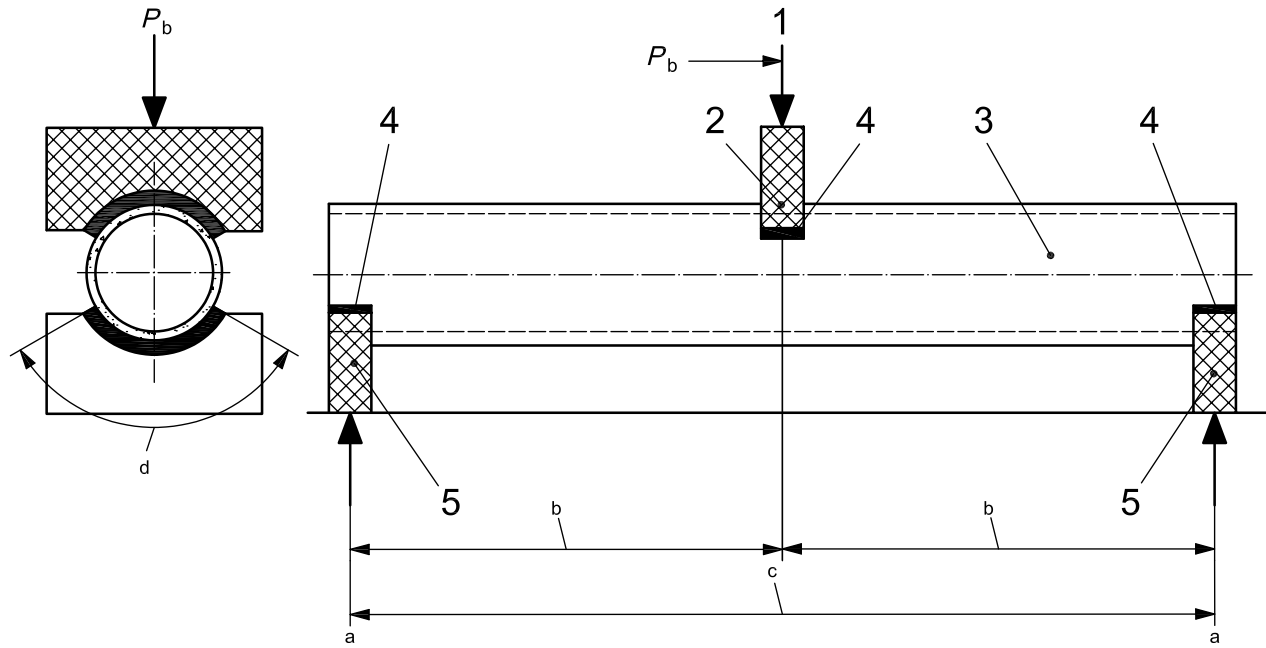

a) Test arrangement for a plain pipe

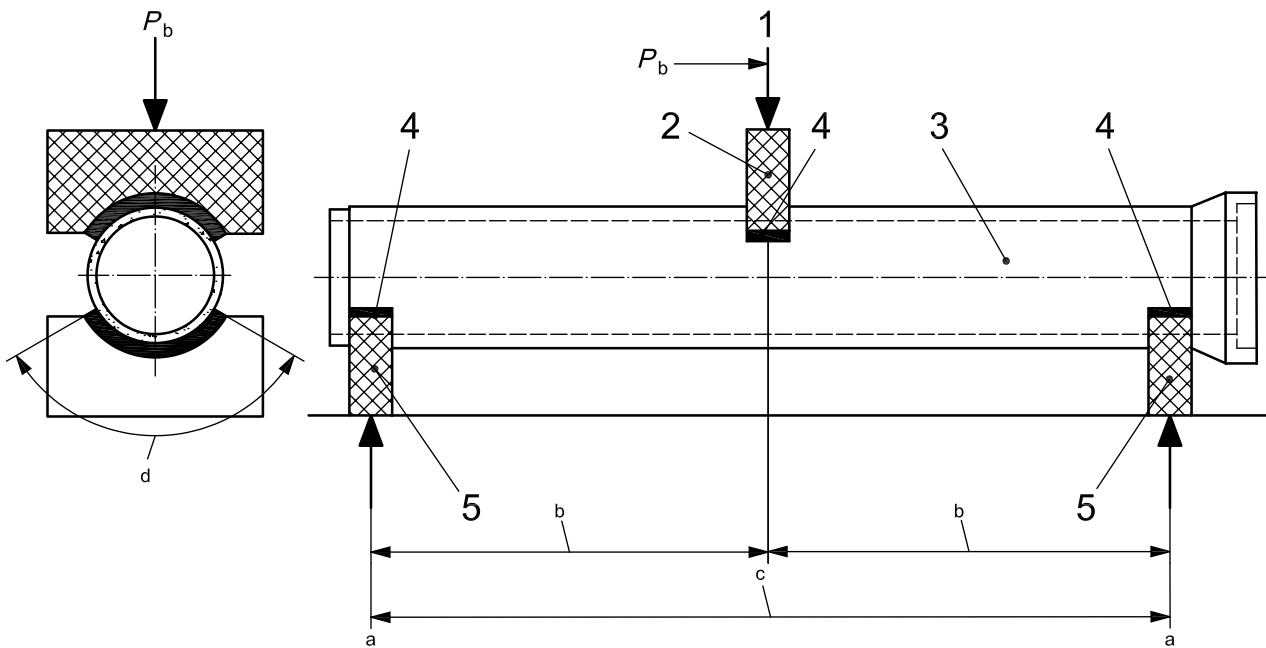

b) Test arrangement for a pipe with an integral socket

Key

- | | | | |
|---|---|-------|---|
| 1 | axis of load application | P_b | applied bending load |
| 2 | load application bearer | a | Half the applied bending load, $0,5 \times P_b$. |
| 3 | polyester resin concrete (PRC) test piece | b | $0,5 \times l_b$. |
| 4 | elastomeric material, (20 ± 5) mm thick | c | Distance between centres of lower bearing blocks, l_b . |
| 5 | bottom bearing block, $1,5 \times DN$ high and (75 ± 5) mm wide | d | 120° . |

Figure C.2 — Arrangement for the three-point loading method

C.4 Procedure

C.4.1 General

Place the test piece in the loading frame and position it in the manner described in C.4.2 or C.4.3, as appropriate. The test piece shall be a whole pipe or a short pipe, with a length of at least either 1,0 m or six times its internal diameter, whichever is greater.

NOTE When testing a whole pipe, the laying length is used as the length of the test piece.

C.4.2 Four-point loading method

Support the test piece in a horizontal position on two slings complying with C.3.2.1 perpendicular to its longitudinal axis and symmetrical about the centre of its length. Place two loading slings on top of the test piece, symmetrical about the centre of the gap between the supporting slings. The distance between the centres of the loading slings shall be (300 ± 2) mm. For details of the arrangement, see Figure C.1.

Attach the loading slings to the loading machine and apply the load as described under C.4.4.

C.4.3 Three-point loading method

Support the test piece in a horizontal position on two bearing blocks complying with C.3.2.2, which have been placed on a firm unyielding horizontal support. The distance between the centres of these bearing blocks shall be at least 0,15 m less than the length of the test piece and they shall be placed symmetrically about the centre of its length. Position the bearing block conforming to C.3.2.2, through which the load is to be applied, mid-way along the length of the test piece. For details of the arrangement, see Figure C.2.

Using the loading machine, apply the load as described under C.4.4.

This method is only usable when the mode of fracture is clearly “beam” failure (i.e. if no end crush occurs prior to the required test load being achieved). Should this not be the failure mode, then this shall be recorded in the test report and the test repeated with another test piece, but using the four-point loading method in accordance with C.4.2.

C.4.4 Load application

Apply the load to the test piece continuously, at a rate of between 6 kN/min and 9 kN/min, without sudden vibration or shock, through the loading slings or the upper bearing block until

- a) the test piece fails, or
- b) the specified minimum longitudinal bending moment resistance, M_{BMR} , is reached, or
- c) the load is increased until the test piece fails.

Record the load applied and the appearance and dimensions of the test piece. Also record the spacing of the slings or the spacing of the bearing blocks.

C.5 Calculations

Calculate the longitudinal bending moment which the pipe resisted, M_3 , when tested using three-point loading, or M_4 , when tested using four-point loading, in kilonewton metres (kNm), using Equation (C.1) or (C.2), as appropriate.

Compare the calculated value, M_3 or M_4 , to the required longitudinal bending moment resistance, M_{BMR} , specified in 5.4.2.

C.5.1 When using the four-point loading method

$$M_4 = P_b \times \frac{l_a}{2} \quad (\text{C.1})$$

where

P_b is the total bending load applied, in kilonewtons;

l_a is the lever arm length, i.e. $0,5 \times (l_s - 0,3)$, in metres,

where

l_s is the support span, in metres.

C.5.2 When using the three-point loading method

$$M_3 = P_b \times \frac{l_b}{4} \quad (\text{C.2})$$

where

P_b is the total bending load applied, in kilonewtons;

l_b is the distance between the centres of the lower bearing blocks, in metres.

C.6 Test report

The test report shall include the following information:

- a) a reference to this part of ISO 18672 and this annex, i.e. ISO 18672-1:2009, Annex C;
- b) full identification of the pipe tested, including the cross-sectional shape, i.e. C or K;
- c) the number of test pieces;
- d) the dimensions of each test piece;
- e) the date, time and place of testing;
- f) whether the four-point or three-point loading method was used;
- g) for each test piece, the total bending load applied, P_b ;
- h) for each test piece, the distance between the centres of the lower bearing blocks, l_b , if applicable;
- i) for each test piece, the lever arm length, l_a , the distance between the centres of the loading slings and the support span, l_s , if applicable;
- j) for each test piece, the calculated value for the bending moment resistance, M_3 or M_4 ;
- k) for each test piece, the specified minimum longitudinal bending moment resistance, M_{BMR} ;
- l) for each test piece, whether the failure was beam failure or not;

- m) equipment details;
- n) a description of the test pieces after testing;
- o) any factors not specified in this part of ISO 18672 which may have affected the results, such as incidents or operating details.

Annex D (normative)

Test method for the determination of the compressive strength of polyester resin concrete (PRC) using test pieces cut from a pipe

D.1 General

This annex describes a test method to determine the compressive strength of the polyester resin concrete (PRC) material used for the manufacture of pipes complying with this part of ISO 18672. The test is applicable to pipes having a circular, egg-shaped or kite-shaped cross-section of any nominal size. It includes requirements for cubes cut from pipes.

D.2 Principle

Test pieces are cubes cut from a pipe made from polyester resin concrete (PRC). The test pieces are crushed in accordance with the method described in this annex and from knowledge of the maximum load applied, in newtons (N), and the dimensions of the test piece, in millimetres (mm), the compressive strength is computed in newtons per square millimetre (N/mm²). This property is used to show compliance with the minimum requirements specified in 5.4.3 and to calculate the capacity of the pipe to resist longitudinal loads in installation applications such as jacking.

D.3 Apparatus

D.3.1 Masonry saw, capable of cutting polyester resin concrete (PRC) test pieces to the form and accuracy required.

D.3.2 Measuring equipment, capable of determining the dimensions and shape of test pieces, to the accuracy required by the test method.

D.3.3 Loading frame.

The loading frame shall be a frame of sufficient rigidity such that the load will not be affected by the deformation or yielding of any part and shall transmit the load evenly to the test piece. The machine shall be capable of applying a compressive load at a controlled rate and without shock to a test piece and measuring, indicating and recording the maximum load applied. The indicated load shall be accurate to within ± 1 % of the indicated value.

D.3.4 Load application platens.

Platens made of steel and having a thickness of at least 25 mm, through which the load is applied to the surfaces of the test piece. The load application surfaces shall be smooth and of a sufficient size to apply the load evenly over the test piece's upper and lower surfaces. The platens shall be 80 mm \times 80 mm square.

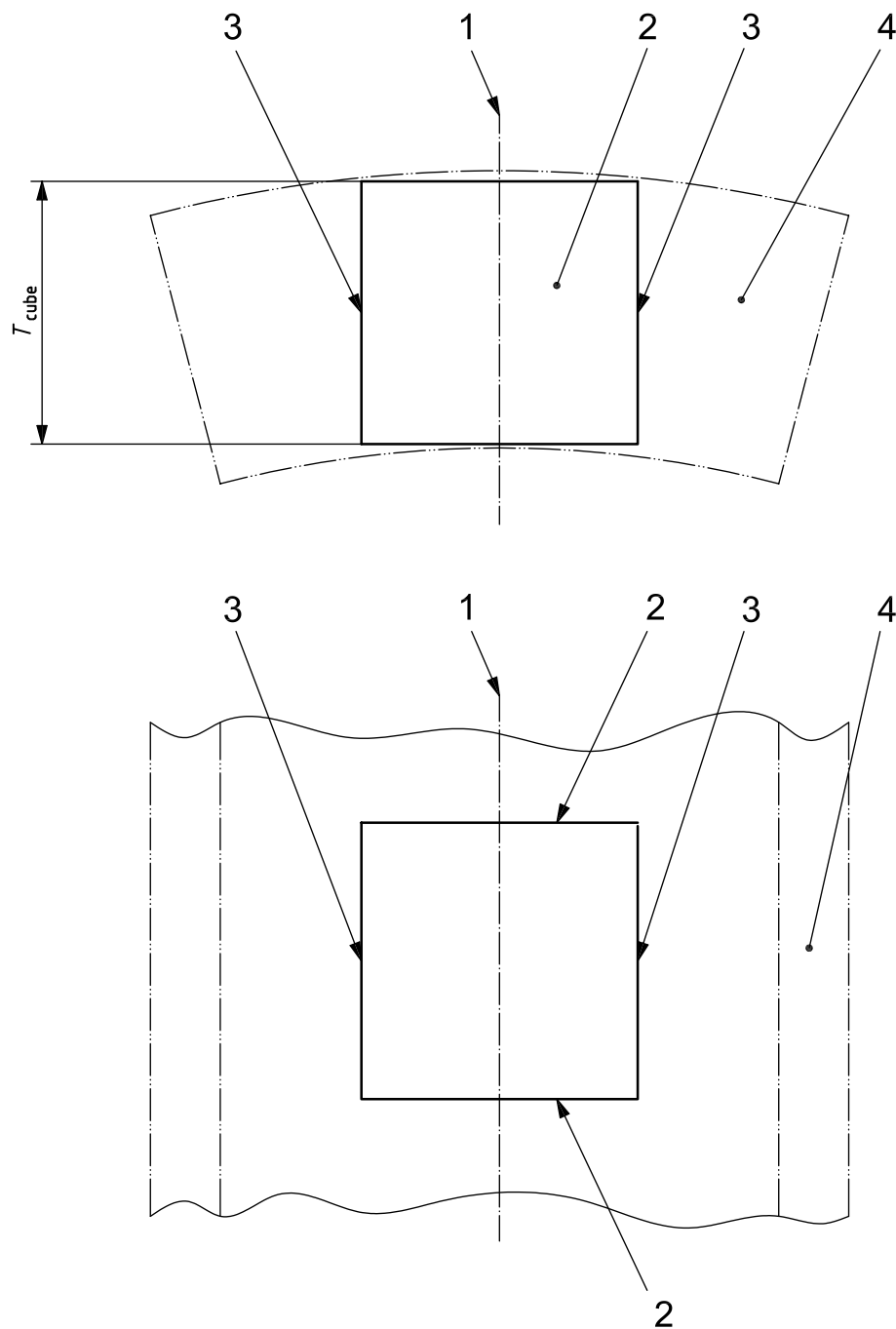

Key

- 1 longitudinal axis of pipe
- 2 test face of test piece
- 3 vertical face parallel to longitudinal axis
- 4 pipe wall
- T_{cube} height, width and length of test piece

Figure D.1 — Details of test piece cut from a pipe

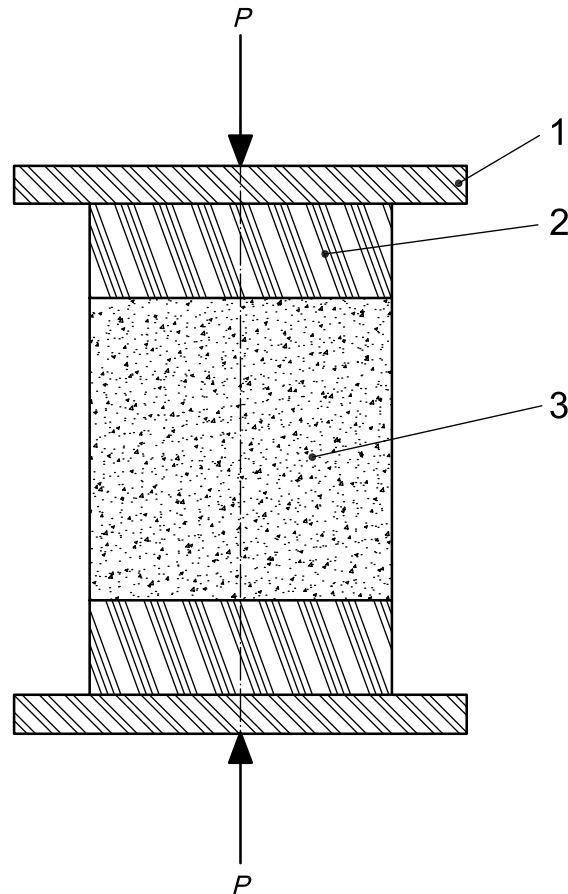

Key

- 1 load application surface of loading frame
- 2 80 mm × 80 mm × 25 mm thick steel test platen
- 3 polyester resin concrete (PRC) test piece
- P* load applied through centre line of loading frame

Figure D.2 — Test arrangement using test pieces cut from a pipe

D.4 Test pieces

Test pieces shall be obtained by cutting along planes which are parallel or perpendicular to the pipe’s longitudinal axis. The width, height and length of the test piece shall be equal to T_{cube} in Figure D.1. The surfaces of the test piece to be loaded shall be parallel and plane to within 0,2 mm. If the wall thickness of the pipe is such that the dimension T_{cube} is more than 80 mm, then it is permissible to cut test pieces in the form of 80 mm cubes.

Before cutting test pieces, inspect the polyester resin concrete (PRC) to ensure that it is damage-free.

D.5 Procedure

Ensure that all testing-machine bearing surfaces are wiped clean and also the surfaces of the test piece which will be loaded in the test. The machine’s load application surfaces shall be larger than or equal to the test piece’s loaded surface. Position a pair of platens as described in D.3.4 centrally in the machine. Centre the test piece in the machine (see Figure D.2).

Apply the load without shock at a rate between 10 N/mm² per min and 20 N/mm² per min. Continue until failure occurs and record the maximum load applied to the test piece. Inspect the test piece and note the nature of any unusual failure modes.

D.6 Calculations

Calculate the compressive strength by dividing the maximum load applied to the test piece, in newtons (N), by the cross-sectional area being loaded, in square millimetres (mm²). Express the result to the nearest 0,5 N/mm².

D.7 Test report

The test report shall include the following information:

- a) a reference to this part of ISO 18672 and this annex, i.e. ISO 18672-1:2009, Annex D;
- b) full identification of the pipe from which the test piece was obtained;
- c) the date, time and place of sampling;
- d) the number of test pieces made and tested and their identification numbers or code;
- e) the dimensions of each test piece and, if applicable, its mass and calculated density;
- f) the date, time and place of testing;
- g) for each test piece, whether it failed or not;
- h) the loaded area, maximum load at failure and calculated compressive strength;
- i) the appearance of the test piece after test;
- j) details of test equipment;
- k) the temperature during testing;
- l) any factors not specified in this part of ISO 18672 which may have affected the results, such as incidents or operating details.

Annex E (normative)

Test method for the determination of the fatigue strength of a pipe under cyclic loading

E.1 General

This test assesses the capacity of a pipe to resist external cyclic loadings perpendicular to its axis along its length.

This test is applicable to pipes of any nominal size, having a circular, egg-shaped or kite-shaped cross-section.

The pipes are tested using test pieces which have been cut from them.

E.2 Principle

The test piece is subjected to a load cycling between an upper and lower limit, at a frequency not exceeding 12 Hz, for a specified number of cycles, without failure.

The fatigue strength, σ_{fat} , is the difference between the upper limit of ring bending tensile stress, σ_{up} , determined from the upper load, and the lower limit of ring bending tensile stress, σ_{low} , determined from the lower load.

E.3 Apparatus

E.3.1 Loading frame, capable of applying a cyclic compressive load to the test piece, without shock or impact, until either the required minimum number of cycles is reached or the test piece fails. The cyclic load shall be applied between specified upper and lower limits at a frequency not exceeding 12 Hz.

The machine shall be sufficiently rigid, so that the distribution of the load is not affected by the deformation or yielding of any part, and shall transmit the load in a vertical plane through the longitudinal centre lines of the test piece.

The load shall be applied in such a way that the combination of support and bearers is free to rotate in a vertical plane through the longitudinal centre lines of the top and bottom bearers.

Free movement of the bottom bearing beams shall be ensured.

The machine shall be equipped with a means of measuring, indicating and recording the upper and lower loads applied to the test piece, which is accurate to within $\pm 2\%$ of the load applied. The machine shall also be equipped with a means of counting, indicating and recording the number of cycles completed.

E.3.2 Bearers and contact surfaces.

The bearers shall be made of metal or a suitable hardwood which is straight and free of warping, twisting or knots.

The bearers shall have a thickness of not less than 25 mm.

The load shall be applied through the compression beam.

The bottom bearing-beam surfaces that are in contact with the test piece shall be in the form of facings to the beams (see Figure E.1). They shall either be of an elastomeric material, having a hardness of (55 ± 10) IRHD, or of felt, having a density of $(0,3 \pm 0,025)$ grams/cm³. The compression beam shall not have a facing, and the bottom bearing beams shall have a facing with a thickness of (20 ± 5) mm.

The bottom bearing beams shall be located centrally about the axis of load application on the bottom bearer.

Free movement of the bottom bearers shall be ensured.

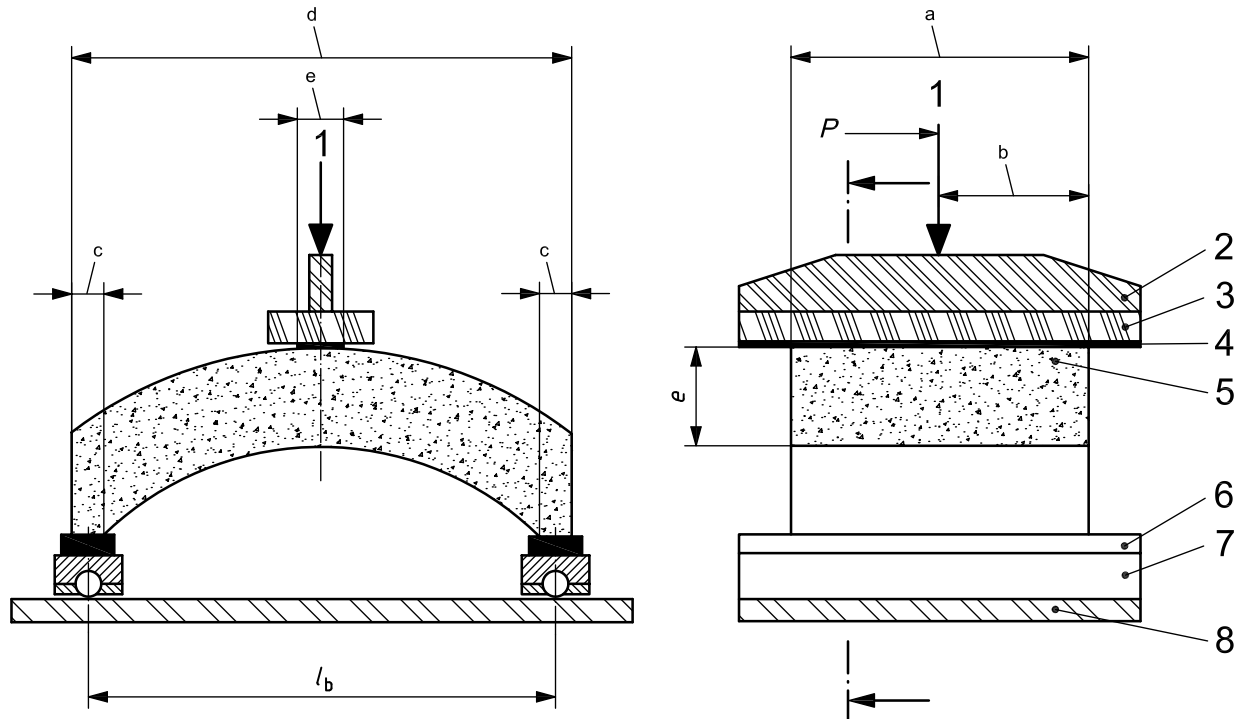

Key

- 1 axis of load application
- 2 compression edge
- 3 compression beam
- 4 elastomeric or felt facing 3 mm thick
- 5 polyester resin concrete (PRC) test piece
- 6 elastomeric or felt facing 20 mm thick
- 7 metal roller bearer to provide movement
- 8 test machine base plate

e wall thickness of test piece

l_b distance between bearers

P applied load

a Width of the test piece, $b = 3 \times e$.

b Location of applied load, $0,5 \times b$.

c Width of the ground surface, $0,33 \times e$.

d Length of test piece, $l_p = 5 \times e$.

e Width of the top bearing strip, $a_b = 0,1 \times l_b$.

Figure E.1 — Test arrangement for fatigue strength using test pieces cut from a pipe

E.4 Test pieces

The test piece shall be sawn from a pipe or a broken piece of a pipe. When testing pipes with kite-shaped or egg-shaped cross-section, the test piece shall be taken from the top of the pipe.

The test piece shall have parallel boundary surfaces. Its length, l_p , shall be about 5 times the wall thickness, e , and its width, b , about 3 times the wall thickness. The longitudinal sides of the test piece shall be perpendicular to the generated surface of the pipe.

The test piece shall be ground at both ends so that the bearing strips, with a width of about one third of the wall thickness, form one single plane.

E.5 Procedure

Calculate the lower and upper loads to be applied to the test piece, using Equation (E.1) or (E.2) as appropriate. Place the test piece horizontally and centrally on the bottom bearing beams. Set the machine to cycle between $P_{\text{calc,low}}$ and $P_{\text{calc,up}}$ and back to $P_{\text{calc,low}}$ at a frequency not exceeding 12 Hz.

NOTE The loads to be applied to the test piece include the loads due to the weight of the compression beam and the compression edge, if applicable.

Apply to the test piece at least 2×10^6 loading cycles which cycle between the calculated upper and lower load. The cycling test force shall be applied steadily until either the specified number of loading cycles is completed or the test piece fails. At completion of the test, record the number of cycles completed and the appearance and dimensions of the test piece.

E.6 Calculations

E.6.1 Upper and lower load

Calculate the upper and lower load to be applied, $P_{\text{calc,low}}$ and $P_{\text{calc,up}}$, in newtons (N), using Equation (E.1) or (E.2) as appropriate:

$$P_{\text{calc,up}} = \sigma_{\text{rb,min}} \times \frac{2 \times b \times e^2}{3 \times l_b \times f_{\text{corr}}} \times f_{\text{up}} \quad (\text{E.1})$$

$$P_{\text{calc,low}} = \sigma_{\text{rb,min}} \times \frac{2 \times b \times e^2}{3 \times l_b \times f_{\text{corr}}} \times f_{\text{low}} \quad (\text{E.2})$$

where

$f_{\text{up}}, f_{\text{low}}$ are, respectively, the factor for the upper (0,4) or the lower (0,1) load;

$\sigma_{\text{rb,min}}$ is the minimum ring bending tensile stress determined in accordance with Annex A or Annex B, in newtons per square millimetre;

l_b is the spacing between the centres of the bearing beams, in millimetres;

b is the width of the test piece, in millimetres;

e is the wall thickness of the test piece, in millimetres;

f_{corr} is the correction factor to allow for stress distribution in the curved beam, derived from Equation (E.3) or (E.4), as applicable:

$$f_{\text{corr}} = \frac{(3 \times d_i) + (5 \times e)}{(3 \times d_i) + (3 \times e)} \quad (\text{E.3})$$

$$f_{\text{corr}} = \frac{(3 \times w_i) + (5 \times e)}{(3 \times w_i) + (3 \times e)} \quad (\text{E.4})$$

where

d_i is the internal diameter of the original pipe, in millimetres;

w_i is the horizontal internal width of a pipe with egg-shaped cross-section, in millimetres.

E.6.2 Fatigue strength

If the specified number of loading cycles is completed without failure, calculate the fatigue strength, σ_{fat} , in newtons per square millimetre (N/mm²), using Equation (E.5):

$$\sigma_{\text{fat}} = \sigma_{\text{up}} - \sigma_{\text{low}} \quad (\text{E.5})$$

where

σ_{up} is the upper limit of the ring bending tensile stress determined from the upper load, in newtons per square millimetre, and is calculated using Equation (E.6):

$$\sigma_{\text{up}} = \sigma_{\text{rb,min}} \times f_{\text{up}} \quad (\text{E.6})$$

where

$\sigma_{\text{rb,min}}$ is the minimum ring bending tensile stress determined in accordance with Annex A or Annex B, in newtons per square millimetre;

f_{up} is the factor for the upper (0,4) load;

σ_{low} is the lower limit of the bending tensile stress determined from the lower load, in newtons per square millimetre, and is calculated using Equation (E.7):

$$\sigma_{\text{low}} = \sigma_{\text{rb,min}} \times f_{\text{low}} \quad (\text{E.7})$$

where

$\sigma_{\text{rb,min}}$ is the minimum ring bending tensile stress determined in accordance with Annex A or Annex B, in newtons per square millimetre;

f_{low} is the factor for the lower (0,1) load.

E.7 Test report

The test report shall include the following information:

- a) a reference to this part of ISO 18672 and this annex, i.e. ISO 18672-1:2009, Annex E;
- b) full identification of the pipe from which the test piece was obtained;
- c) the date, time and place of sampling;
- d) the number of test pieces made and tested and their identification numbers or codes;
- e) the dimensions of each test piece;
- f) the date, time and place of testing;
- g) for each test piece, the upper load, $P_{\text{calc,up}}$, and lower load, $P_{\text{calc,low}}$, applied;
- h) for each test piece, the calculated value for σ_{fat} ;
- i) for each test piece, the calculated value for f_{corr} ;
- j) the spacing between the centres of the bearing beams, l_b ;
- k) the number of cycles completed by each test piece;
- l) equipment details;
- m) a description of the test piece after testing;
- n) any factors not specified in this part of ISO 18672 which may have affected the results, such as incidents or operating details.

.....

Annex F (normative)

Method for the assessment of the leaktightness of a pipe and its joints under short-term exposure to internal water pressure

F.1 General

This test method assesses whether or not a pipe and its joints are leaktight under short-term internal water pressure. This test is applicable to pipes having a circular, egg-shaped or kite-shaped cross-section of any nominal size together with their joints.

WARNING — Attention is drawn to dangers associated with pressure and the need to apply all necessary precautions to prevent injury to the personnel in the vicinity of the test area.

F.2 Principle

A pipe is either installed in a test rig which has platens with suitable joint profiles or joined to another pipe of the same classification. The thrust produced at the ends is transferred to the test rig and is not carried by the test piece. The test arrangement is filled with water, taking care to remove all air, and then pressurized to a specified pressure, which is maintained for 15 min. At the end of this time, the test arrangement is inspected for signs of leakage or weeping. For the pipe and its joints to be considered leaktight, there shall be no sign of leakage or weeping in either the joints or the pipe.

F.3 Apparatus

F.3.1 Test rig, capable of holding the test arrangement for the duration of the test without transmitting loads to either the pipe or its joints.

F.3.2 End-sealing devices, such as end caps, internal stoppers or inflatable bags, of suitable capability and which remain leaktight for the duration of the test. Means shall be provided to prevent movement of the end sealing devices under pressure and to ensure that they do not transmit end thrust to the test piece.

F.3.2 Source of hydrostatic pressure, capable of controlling the test pressure to within $\pm 1\%$ of the specified value for the duration of the test.

F.4 Procedure

Either place the pipe in a test rig which has platens with suitable joint profiles or join two pipes or pipe sections with one flexible joint and clamp in a suitable test rig. If necessary, seal the ends of the pipe using suitable end-sealing devices.

Slowly fill the test arrangement with water, taking care to remove all air.

Using the source of hydrostatic pressure, raise the test pressure, at a rate not exceeding 0,1 bar (10 kPa) in 1 s, until the specified test pressure is reached.

Maintain the test pressure within $\pm 2\%$ of the specified value for 15 min.

After 15 min, inspect the outside of the pipe and the joints for signs of leakage, damp patches or water droplets. Record the result of the inspection.

F.5 Test report

The test report shall include the following information:

- a) a reference to this part of ISO 18672 and this annex, i.e. ISO 18672-1:2009, Annex F;
- b) full identification of the pipe tested, including the cross-sectional shape, i.e. C, E or K;
- c) the joint details, including dimensions and elastomeric seal details;
- d) the number of test pieces;
- e) the test pressure;
- f) the duration of the test or time to failure;
- g) the occurrence or absence of leakage;
- h) equipment details;
- i) any factors not specified in this part of ISO 18672 which may have affected the results, such as incidents or operating details.

Annex G (normative)

Test method for the determination of the long-term (50 years) crushing strength of a pipe, including the effects of media attack

G.1 General

This test determines the capacity of a pipe to resist external long-term loadings perpendicular to the axis along its length, taking into account media attack. The test is applicable to pipes having a circular, egg-shaped or kite-shaped cross-section of any nominal size.

G.2 Principle

This test determines the long-term crushing strength of a pipe after being loaded for 50 years, by extrapolating the results of a long-term test series lasting at least 10 000 h, to take into account the influence of media attack on the invert of the test piece, which shall be exposed to one of the test solutions as described in Clause G.5 and Figure G.1.

NOTE The method can be used to take into account the influence of any particular solution on the long-term crushing strength of a pipe.

The loadings for the test pieces shall be so selected that the times to failure are distributed over the test duration as described under G.6.

The short-term crushing strength of the pipe, determined in accordance with Annex A, is needed as a basis for the loading selection and also for the determination of the reduction factor.

If there is no value for the short-term crushing strength of the pipe to be tested then, before starting the test series, the pipe shall be tested with the method described in Annex A until failure occurs.

G.3 Apparatus

G.3.1 Machine, capable of applying a compressive load permanently to the test piece, which shall be a pipe section having a minimum length as indicated in 5.4.1.2, until either the test has been carried out for not less than 10 000 h without failure or the test piece fails.

A typical arrangement of the test equipment is shown in Figure G.1. This apparatus consists of a rigid beam placed parallel to the floor, a rigid work-arm to introduce the load, with a means of attaching weights on one end, a rigid bearing beam parallel to the floor, rigid support beams, a container, if required, suitable for holding the test solution, weights and drop protection for the weights.

The surfaces in contact with the test piece shall be hard, flat, smooth and clean.

The components of the test apparatus shall be rigid enough to prevent any visible deformation during the test.

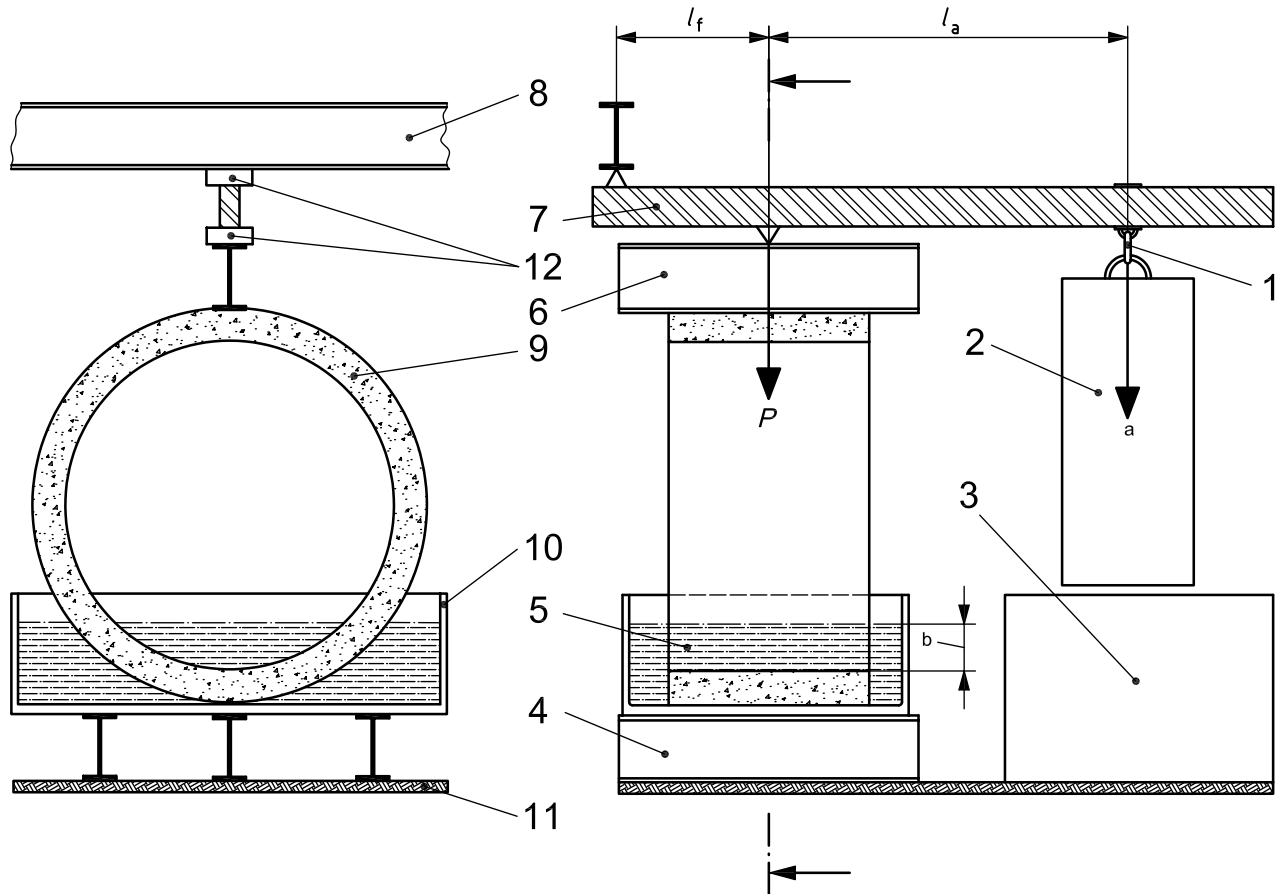

Key

- | | | | |
|---|------------------------|-------|----------------------------|
| 1 | moveable weight hanger | 9 | test piece |
| 2 | weights | 10 | container (if required) |
| 3 | weight drop protection | 11 | bearing plate |
| 4 | supports | 12 | fulcrum |
| 5 | test solution | l_a | lever arm |
| 6 | compression beam | l_f | distance between fulcrums |
| 7 | work arm | P | load applied to test piece |
| 8 | rigid beam | | |
- a Mass of weights.
 b Minimum depth of test liquid at invert, 25 mm.

Figure G.1 — Typical test arrangement for the long-term crushing strength test

G.4 Test pieces

The test pieces for the same test series shall come from pipes of the same type, nominal size and strength class.

The test pieces shall be pipe sections with a length not less than the requirements of 5.4.1.2. The ends of the test piece shall be cut plane and perpendicular to the pipe axis.

Two straight, longitudinal lines, functioning as reference lines, are drawn on the pipe's inner or outer surface at 180° to each other.

At least 18 test pieces are required for one test series.

G.5 Test solutions

G.5.1 Acid test solution (1 N)

The acid test solution shall be a 0,5 mol/l sulfuric acid solution $c(\text{H}_2\text{SO}_4)$ prepared by adding 28,5 ml of concentrated sulfuric acid (1,84 g/ml) to 971,5 ml of distilled water to produce 1 litre of test solution.

G.5.2 Alkali test solution (pH 10)

The alkali test solution shall be a buffer solution of sodium carbonate (Na_2CO_3) and sodium bicarbonate (NaHCO_3) prepared by dissolving 2,640 g of sodium carbonate and 2,092 g of sodium bicarbonate in 800 ml of distilled water and then topping up to make 1 000 ml of test solution.

G.6 Procedure

Determine the short-term crushing strength of a pipe of the same size and classification, in accordance with Annex A.

Place a test piece in the container, which is supported by rigid beams. Fill the container with the test solution to a level sufficient to cover the invert of the test piece to a minimum depth of 25 mm.

The concentration of the test solution shall be maintained throughout the test and, if necessary, corrected.

The test temperature shall be maintained at (23 ± 5) °C for the duration of the test.

The load is introduced by concrete weights hanging from the work arms of the individual devices, as shown in Figure G.1.

For the test series, a minimum of 18 failure points is required to determine the regression graph. Select the range of loadings so that the times to failure are distributed between 0,1 h and over 10 000 h; the distribution of these failure points shall conform to Table G.1.

For the duration of the test series, check each test piece at least at the frequency stated in Table G.2.

The test on an individual test piece is deemed to have been completed when either

- a) the test piece fails, or
- b) the test has been carried out for no less than 10 000 h without failure.

Whenever a test piece fails, the load applied and the time to failure shall be recorded.

Table G.1 — Failure point distribution

Test duration in hours	Minimum number of failure points
10 to 1 000 h	4
1 000 to 6 000 h	3
6 000 to 10 000 h	2
more than 10 000 h	1
NOTE The distribution of the other failure points is not specified.	

Table G.2 — Frequency of test piece inspections

Test duration in hours	Checking times
0 to 20 h	every hour
20 to 40 h	every 2 h
40 to 60 h	every 4 h
60 to 100 h	every 8 h
100 to 600 h	every 24 h
600 to 6 000 h	every 48 h
after 6 000 h	every week

G.7 Evaluation — Long-term (50 years) crushing strength

Determine the long-term crushing strength of a pipe loaded for 50 years by making an extrapolation with the data from a test series using Method A in ISO 10928. The crushing strengths used in the analysis shall be expressed as a percentage of the initial strength. The test pieces, which have not failed after 10 000 h, may be included as failures to establish the regression line. If required, the values can be represented in a double logarithm coordinate grid, with time to failure being entered on the X-axis and crushing strength, expressed as a percentage of the initial strength, entered on the Y-axis.

G.8 Test report

The test report shall include the following information:

- a) a reference to this part of ISO 18672 and this annex, i.e. ISO 18672-1:2009, Annex G;
- b) full identification of the pipe tested, including the cross-sectional shape, i.e. C, E or K;
- c) the number of test pieces;
- d) the dimensions of each test piece;
- e) the date, time and place of testing;
- f) the length of the lever arm, l_a , and distance between fulcrums, l_f ;
- g) the crushing load applied and time to failure for each test piece;
- h) the times of checking for each test piece;
- i) the control of composition and concentration of the test solution and the procedure used;
- j) for each test series, the short-term crushing strength;
- k) for each test series, the extrapolated long-term crushing strength (50 years);
- l) details of the equipment;
- m) the temperature during the test;
- n) a description of the test pieces after testing;
- o) any factors not specified in this part of ISO 18672 which may have affected the results, such as incidents or operating details.

ICS 23.040.20; 23.040.45; 91.140.80; 93.030

Price based on 68 pages