

---

---

**Building construction machinery and  
equipment — Internal vibrators for  
concrete —**

**Part 1:  
Terminology and commercial  
specifications**

*Machines et matériels pour la construction des bâtiments — Vibrateurs  
internes pour le béton —*

*Partie 1: Terminologie et spécifications commerciales*



Reference number  
ISO 18651-1:2011(E)

© ISO 2011



**COPYRIGHT PROTECTED DOCUMENT**

© ISO 2011

All rights reserved. Unless otherwise specified, no part of this publication may be reproduced or utilized in any form or by any means, electronic or mechanical, including photocopying and microfilm, without permission in writing from either ISO at the address below or ISO's member body in the country of the requester.

ISO copyright office  
Case postale 56 • CH-1211 Geneva 20  
Tel. + 41 22 749 01 11  
Fax + 41 22 749 09 47  
E-mail [copyright@iso.org](mailto:copyright@iso.org)  
Web [www.iso.org](http://www.iso.org)

Published in Switzerland

# Contents

Page

|  |          |
|--|----------|
| Foreword .....   | iv       |
| <b>1 Scope .....</b>   | <b>1</b> |
| <b>2 Normative references .....</b>  | <b>1</b> |
| <b>3 Terms and definitions .....</b>   | <b>1</b> |
| <b>4 Structure.....</b>  | <b>3</b> |
| <b>5 Commercial specifications .....</b>   | <b>4</b> |
| <b>5.1 Basic data for all types of immersion vibrator .....</b>                                  | <b>4</b> |
| <b>5.2 Complementary data for all types of immersion vibrator .....</b>                          | <b>4</b> |
| <b>5.3 Complementary data for particular immersion vibrator types and associated units .....</b> | <b>4</b> |
| <b>5.3.1 Electric immersion vibrators with flexible drive .....</b>                              | <b>4</b> |
| <b>5.3.2 Built-in motor type electric immersion vibrators .....</b>                              | <b>5</b> |
| <b>5.3.3 Frequency and voltage converter .....</b>   | <b>5</b> |
| <b>5.3.4 Generating set for electric supply .....</b>  | <b>6</b> |
| <b>5.4 Immersion vibrators with flexible drive and internal combustion engine.....</b>           | <b>6</b> |
| <b>5.5 Pneumatic immersion vibrators.....</b>  | <b>7</b> |
| <b>5.6 Hydraulic vibrators.....</b>  | <b>7</b> |
| <b>Annex A (informative) Examples of internal vibrator structures .....</b>                      | <b>8</b> |

## Foreword

ISO (the International Organization for Standardization) is a worldwide federation of national standards bodies (ISO member bodies). The work of preparing International Standards is normally carried out through ISO technical committees. Each member body interested in a subject for which a technical committee has been established has the right to be represented on that committee. International organizations, governmental and non-governmental, in liaison with ISO, also take part in the work. ISO collaborates closely with the International Electrotechnical Commission (IEC) on all matters of electrotechnical standardization.

International Standards are drafted in accordance with the rules given in the ISO/IEC Directives, Part 2.

The main task of technical committees is to prepare International Standards. Draft International Standards adopted by the technical committees are circulated to the member bodies for voting. Publication as an International Standard requires approval by at least 75 % of the member bodies casting a vote.

Attention is drawn to the possibility that some of the elements of this document may be the subject of patent rights. ISO shall not be held responsible for identifying any or all such patent rights.

ISO 18651-1 was prepared by Technical Committee ISO/TC 195, *Building construction machinery and equipment*, Subcommittee SC 1, *Machinery and equipment for concrete work*.

ISO 18651 consists of the following parts, under the general title *Building construction machinery and equipment — Internal vibrators for concrete*:

— *Part 1: Terminology and commercial specifications*

.....

# Building construction machinery and equipment — Internal vibrators for concrete —

## Part 1: Terminology and commercial specifications

### 1 Scope

This part of ISO 18651 specifies the terminology and gives commercial specifications for internal vibrators used for concrete mix compaction.

### 2 Normative references

The following referenced documents are indispensable for the application of this document. For dated references, only the edition cited applies. For undated references, the latest edition of the referenced document (including any amendments) applies.

ISO 11375, *Building construction machinery and equipment — Terms and definitions*

### 3 Terms and definitions

For the purposes of this document, the terms and definitions given in ISO 11375 and the following apply.

#### 3.1

##### **immersion vibrator with flexible drive**

vibrator with drive transmission from prime mover to vibration head in the form of a flexible drive shaft

NOTE The drive shaft may be enclosed within an outer sheath to permit handling during use.

#### 3.1.1

##### **electric immersion vibrator with flexible drive**

vibrator in which the drive for the vibration generator is composed of an electric motor with a flexible drive shaft to the vibration unit

NOTE 1 The drive shaft may be enclosed within an outer sheath to permit handling during use.

NOTE 2 For an example, see Figure A.8.

#### 3.1.2

##### **combustion engine immersion vibrator with flexible drive**

vibrator in which the drive for the vibration generator is composed of an internal combustion engine with a flexible drive shaft to the vibration unit

NOTE For an example, see Figure A.9.

### 3.2

#### **built-in motor-type electric immersion vibrator**

vibrator in which an electric motor and the vibration generator are both enclosed in the vibration head

NOTE 1 Typically, it is composed of a frequency and voltage converter, protective hose and control box with contactor.

NOTE 2 It can be classified as either an external converter type or integrated converter type.

NOTE 3 For examples, see Figures A.2, A.3 and A.4.

### 3.3

#### **hydraulic immersion vibrator**

vibrator comprised of a rotating eccentric mass directly coupled to a hydraulic motor to produce a stable and powerful vibration

NOTE 1 The method of control typically enables precise regulation of frequency. These units are usually designed for use in the production of large concrete elements with large aggregate.

NOTE 2 For an example, see Figure A.5.

### 3.4

#### **pneumatic immersion vibrator**

vibrator using compressed air and provided with a vibration head comprising a pneumatic motor

NOTE 1 Typically, it is composed of a vibration head, protective hose (incorporating air supply) and twist grip throttle control.

NOTE 2 For an example, see Figure A.6.

### 3.5

#### **portable-type immersion vibrator**

vibrator all of whose components are handled by an operator during operation

### 3.6

#### **vibration head**

vibrator comprised of a vibration generator that is immersed in the concrete mix for the purpose of its compaction

NOTE 1 The vibration head typically has a cylindrical form and its end is adapted for coupling a driving unit or power network.

NOTE 2 For examples, see Figures A.2, A.3, A.5, A.7, A.8, and A.9.

### 3.7

#### **eccentric-type vibration generator**

mechanism generating harmonic vibration by the eccentricity of a mass rotating inside the casing in bearings

### 3.8

#### **pendulum-type vibration generator**

mechanism generating vibration with a pendulum by rotating an out-of-balance mass along a circular path

### 3.9

#### **flexible drive shaft**

component made of flexible material or of segments that transmit rotary motion from a power source to a vibration head

NOTE Since the drive shaft may also be used as a handling medium, it will typically have a protective shroud that permits the shaft to rotate within the shroud.

**3.10****protective hose**

medium used to hold the insulated electric motor or the hose carrying compressed air to the pneumatic motor in the vibration head, and which will incorporate appropriate protective devices or mechanisms

**3.11****flexible-type structure**

vibrator comprising a flexible shaft or protective hoses for pneumatic and hydraulic designs and a flexible conductor for supply

NOTE For examples, see Figures A.1 a), A.8 and A.9.

**3.12****holding-type structure**

vibrator equipped with a handle

NOTE For examples, see Figures A.2, A.6 and A.8.

**3.13****compaction diameter**

diameter of an area corresponding to an extent of the measurable action of compaction during the vibrator's operation

NOTE The compaction diameter will depend on the vibrator's parameters, the concrete mix composition and the time of compaction.

**3.14****frequency and voltage converter**

unit used for the electric supply of an immersion vibrator with a frequency higher than that supplied by the power network and, if included, safety voltage

**3.15****high and normal frequency generating set**

unit composed of an internal combustion engine, electric generator and frequency converter

**4 Structure**

The structure of the immersion vibrator is dependent on its type (eccentric or pendulum, flexible-drive or built-in motor types), power source (electric motor, internal combustion engine, compressed air or hydraulic feeding system) and the manner in which the vibrator is held during operation (hose-hold, handle and/or fixed to the apparatus).

Examples of these structures are presented in Annex A.

## 5 Commercial specifications

### 5.1 Basic data for all types of immersion vibrator

The following basic data shall be presented:

- a) diameter of vibration head mm;
- b) length of vibration head mm;
- c) mass of vibration head kg;
- d) total mass of vibrator kg;
- e) centrifugal force kN (no load);
- f) vibration frequency Hz (no load);
- g) double amplitude mm (no load).

### 5.2 Complementary data for all types of immersion vibrator

If available, the compaction diameter (mm) shall also be specified.

### 5.3 Complementary data for particular immersion vibrator types and associated units

#### 5.3.1 Electric immersion vibrators with flexible drive

For electric immersion vibrators, the following data shall also be presented:

- a) electric motor data:
  - 1) motor type: single- or three-phase, synchronous, commutator;
  - 2) rated power and current kW, A;
  - 3) voltage and frequency V, Hz;
  - 4) revolutions  $\text{min}^{-1}$ ;
- b) overall dimensions:
  - 1) length mm;
  - 2) width mm;
  - 3) height mm;
- c) flexible drive shaft length m.



### 5.3.2 Built-in motor type electric immersion vibrators

For built-in motor type electric immersion vibrators, the following data shall also be presented:

- a) electric motor data:
  - 1) motor type;
  - 2) power and current kW, A;
  - 3) voltage and frequency V, Hz;
- b) overall length of the protective hose m;
- c) length of the hose-handle m;
- d) hold part:
  - 1) smooth protective hose with handling part;
  - 2) handle provided with on/off switch.

### 5.3.3 Frequency and voltage converter

For frequency and voltage converters, the following data shall also be presented:

- a) type of converter: single- or three-phase;
- b) input voltage and frequency V, Hz;
- c) output voltage and frequency<sup>1)</sup> V, Hz;
- d) power and current kW, A;
- e) number of output plug sockets
- f) overall dimensions:
  - 1) length mm;
  - 2) width mm;
  - 3) height mm;
  - 4) mass kg;
- g) adaptation for handling: lifting structure or lifting structure and travelling axle.

---

1) Value given when the converter is not an integral component of the vibrator set.

### 5.3.4 Generating set for electric supply

The following data on the high and normal frequency generating set shall also be presented:

- a) internal combustion engine:
  - 1) designation and name of manufacturer
  - 2) engine type:
    - i) spark ignition (two- or four-cycle), or
    - ii) compression ignition;
  - 3) power and revolutions kW, min<sup>-1</sup>;
  - 4) displacement cm<sup>3</sup>;
  - 5) mass kg;
- b) generator:
  - 1) output voltage and frequency V, Hz;
  - 2) power and current kW, A;
  - 3) number of output plug sockets
- c) total mass kg;
- d) overall dimensions:
  - 1) length mm;
  - 2) width mm;
  - 3) height mm.

### 5.4 Immersion vibrators with flexible drive and internal combustion engine

For immersion vibrators with flexible drive that have an internal combustion engine, the following data shall also be presented:

- a) internal combustion engine:
  - 1) designation and name of manufacturer;
  - 2) engine type:
    - i) spark ignition (two- or four-cycle), or
    - ii) compression ignition;
  - 3) power and revolutions kW, min<sup>-1</sup>;
  - 4) displacement cm<sup>3</sup>;
  - 5) mass kg;
- b) length of a flexible drive shaft m.

### 5.5 Pneumatic immersion vibrators

For pneumatic immersion vibrators, the following data shall also be presented:

- a) maximum pressure MPa;
- b) approx. frequency in concrete
  - at nominal pressure Hz;
- c) air consumption rate at nominal pressure m<sup>3</sup>/h;
- d) length of a hose m.

### 5.6 Hydraulic vibrators

For hydraulic vibrators, the following data shall also be presented:

- a) length of hose m;
- b) length of a rigid part of the hose mm;
- c) recommendations for the hydraulic power unit:
  - 1) pump output l/min
  - 2) maximum pressure MPa.

## Annex A (informative)

### Examples of internal vibrator structures

See Figures A.1 to A.10.

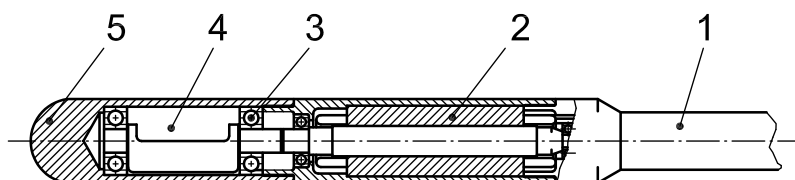

a) Eccentric-type immersion vibrator

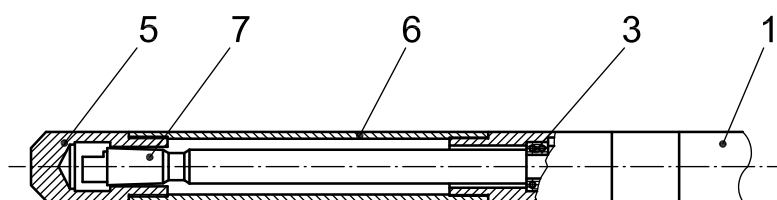

b) Pendulum-type immersion vibrator

#### Key

- 1 flexible drive shaft
- 2 electric motor
- 3 bearing
- 4 eccentric mass
- 5 vibration head
- 6 housing
- 7 pendulum

Figure A.1 — Structure of immersion vibrators

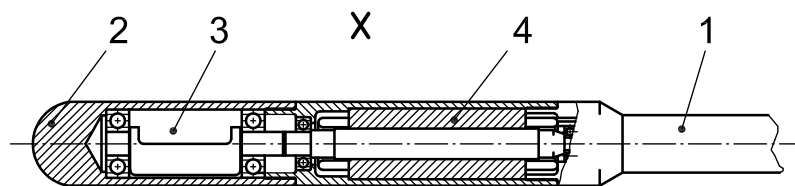
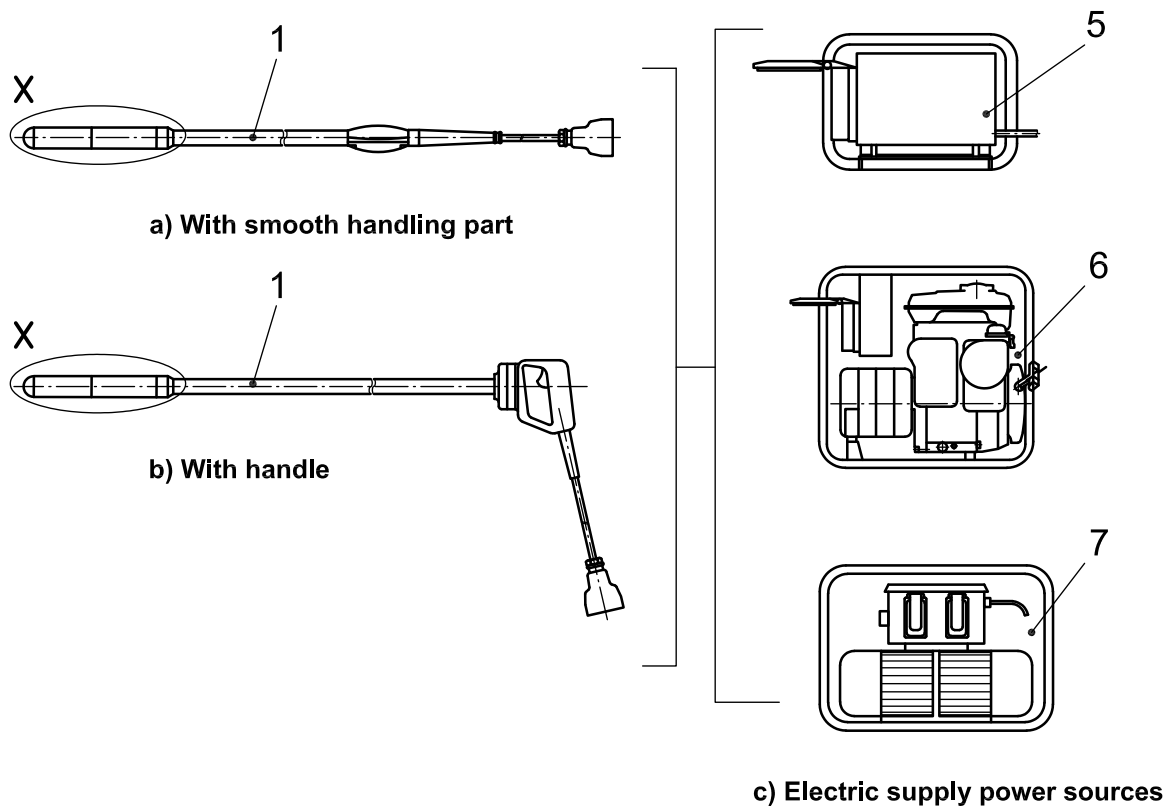

**Key**

- 1 protective hose
- 2 vibration head
- 3 eccentric mass
- 4 electric motor
- 5 inverter
- 6 generator
- 7 frequency converter

**Figure A.2 — Built-in motor-type electric immersion vibrator**

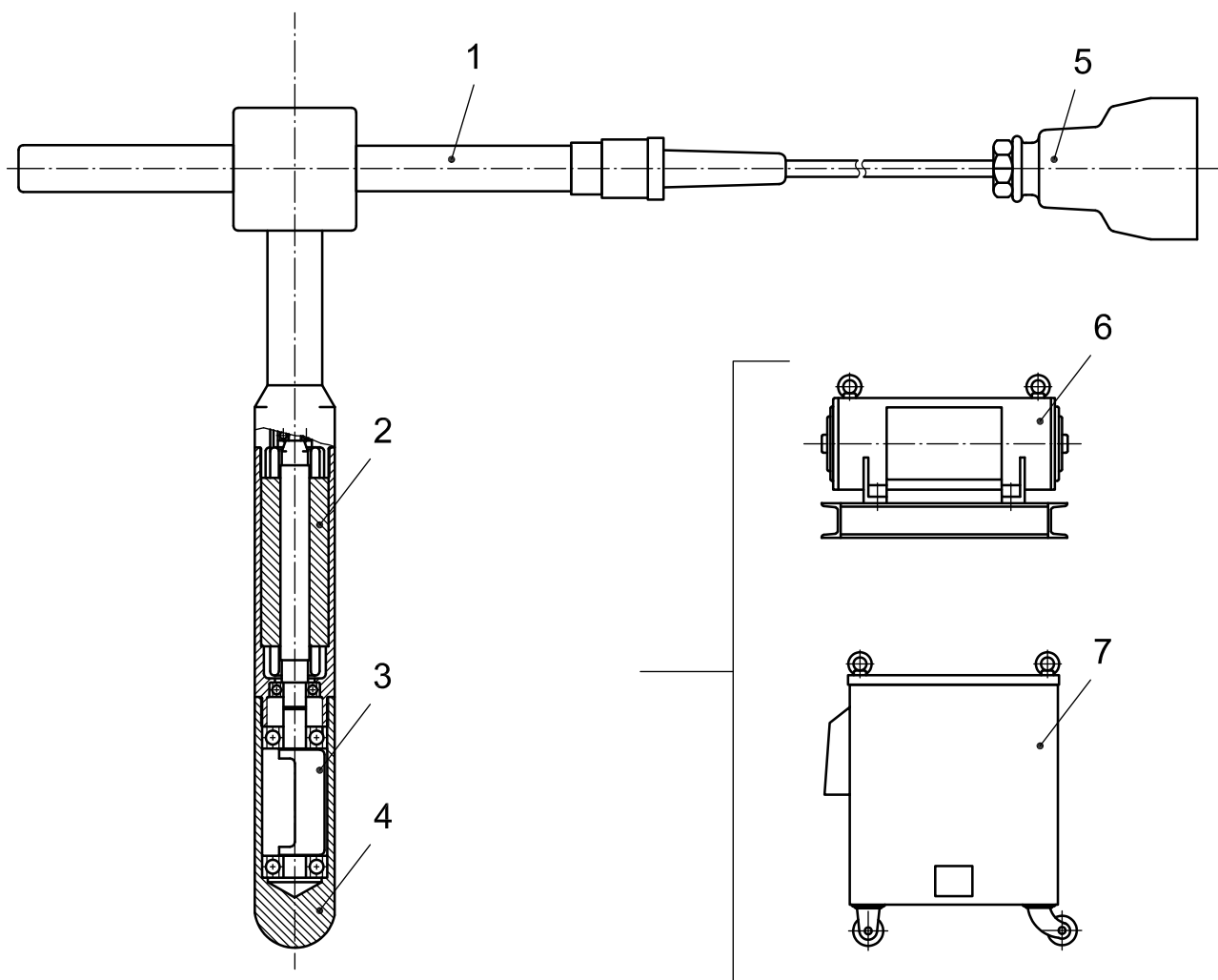

**Key**

- 1 handle
- 2 electric motor
- 3 eccentric mass
- 4 vibration head
- 5 plug
- 6 converter
- 7 inverter

**Figure A.3 — Built-in motor-type electric immersion vibrator with handle**

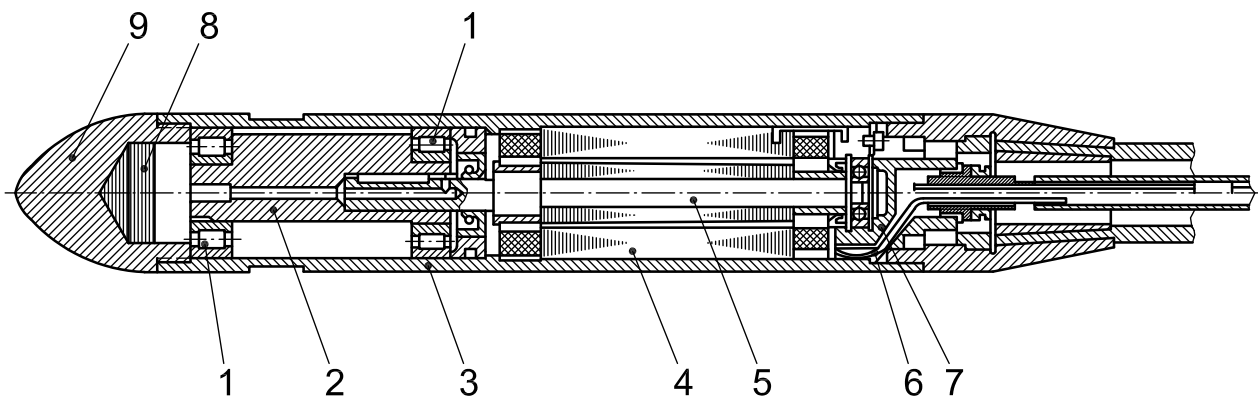

**Key**

- 1 bearings of the shaft with unbalanced mass
- 2 shaft with unbalanced mass
- 3 housing
- 4 stator of the electric motor
- 5 rotor
- 6 thermal break switch
- 7 thermal break switch package
- 8 liquid grease
- 9 vibrator bottom

**Figure A.4 — Built-in motor-type electric immersion vibrator**

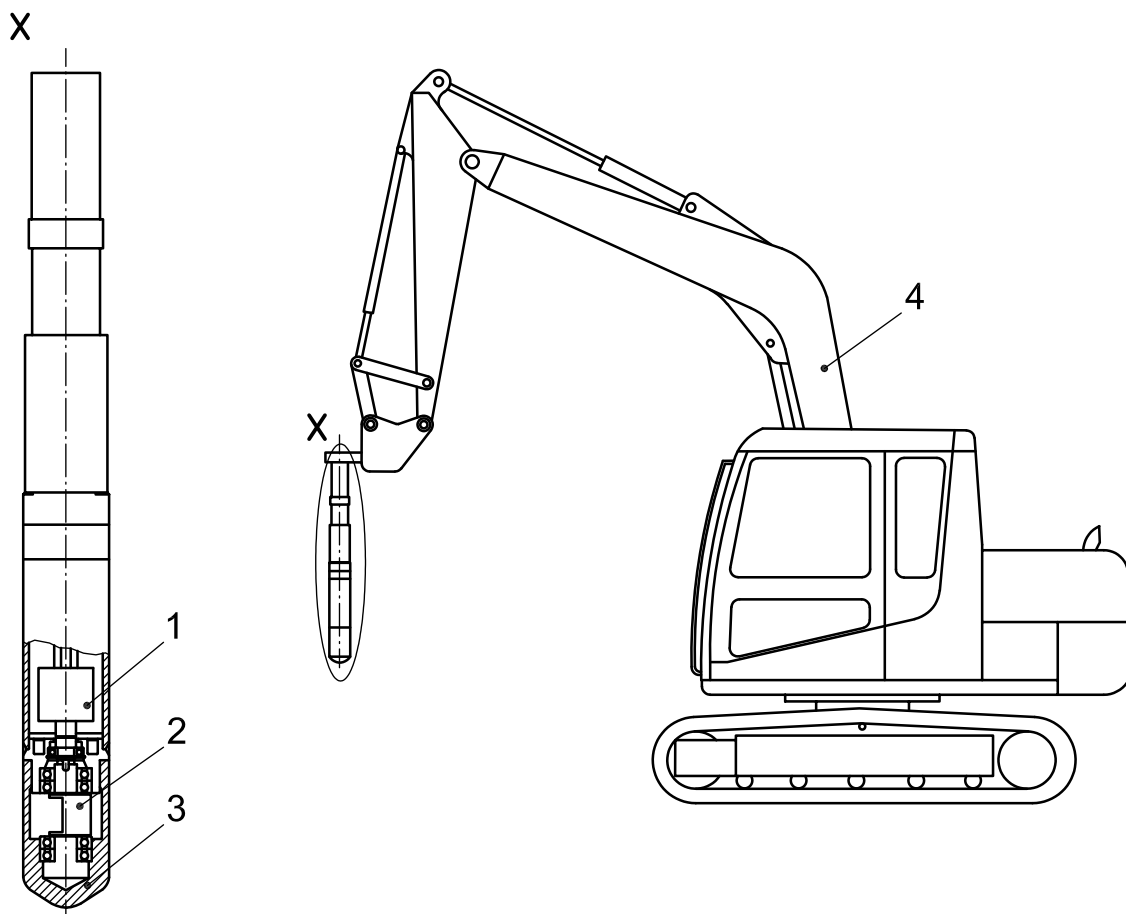

**Key**

- 1 hydraulic motor
- 2 eccentric mass
- 3 vibration head
- 4 base machine

**Figure A.5 — Hydraulic immersion vibrator installed on a base machine**



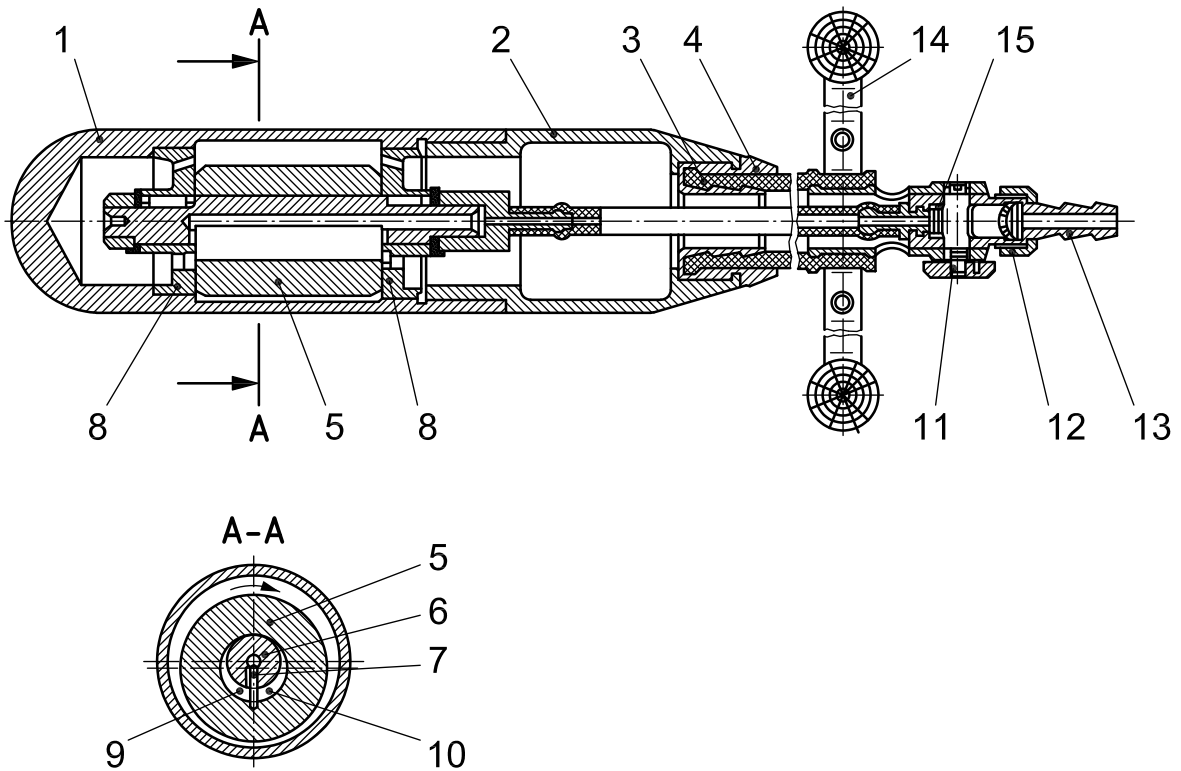

**Key**

- 1 housing, lower part
- 2 housing, upper part
- 3 hose for outlet air
- 4 hose for inlet compressed air to the pneumatic motor
- 5 rotor of the pneumatic motor
- 6 stator of the pneumatic motor
- 7 blade
- 8 faces with hollows for outlet air
- 9 working chamber
- 10 chamber of outlet air
- 11 control valve
- 12 nut
- 13 joint
- 14 handle
- 15 packing washer

**Figure A.6 — Pneumatic immersion vibrator**

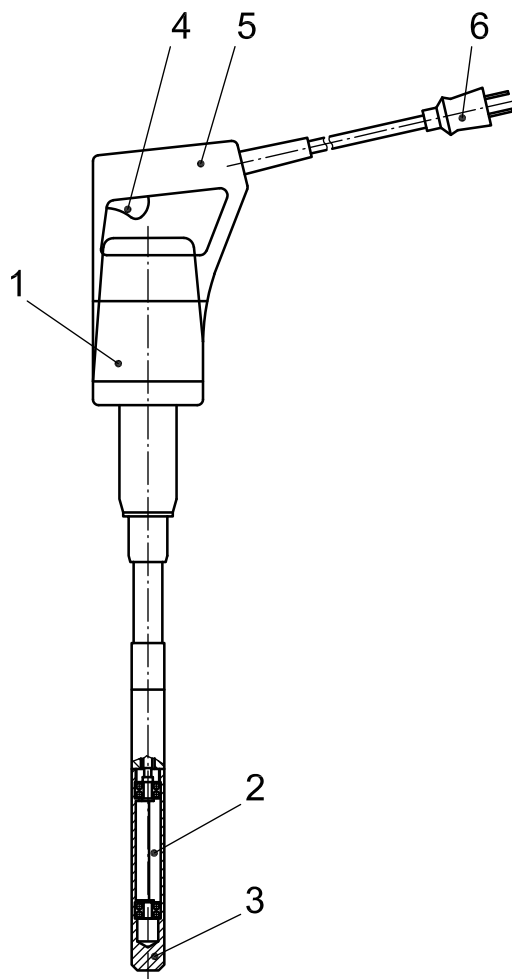

**Key**

- 1 electric motor
- 2 eccentric mass
- 3 vibration head
- 4 switch
- 5 handle
- 6 plug

**Figure A.7 — Portable electric immersion vibrator and motor equipped with handle**

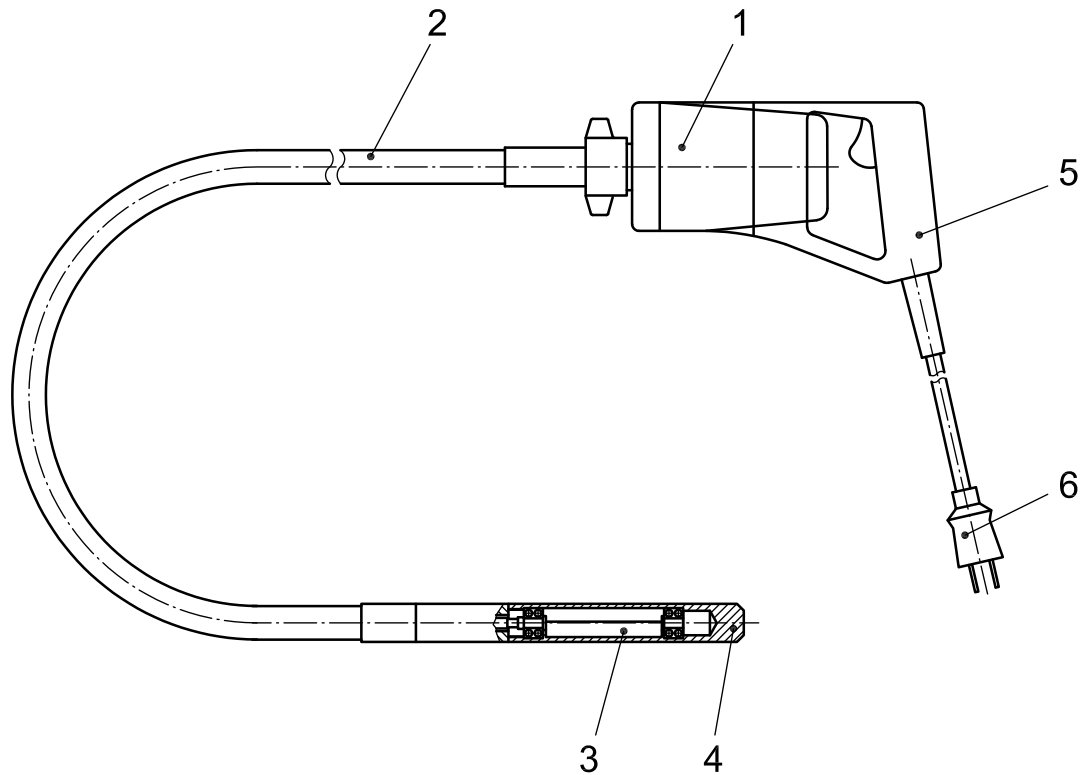

**Key**

- 1 electric motor
- 2 flexible drive shaft
- 3 eccentric mass
- 4 vibration head
- 5 handle
- 6 plug

**Figure A.8 — Electric immersion vibrator with flexible drive shaft and motor equipped with handle**

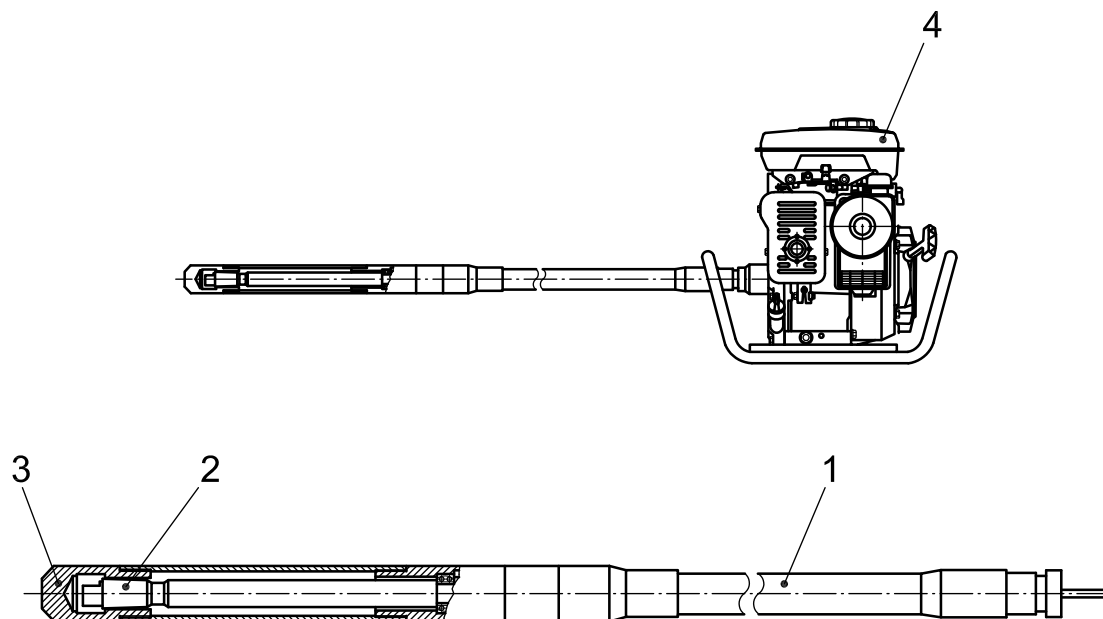

**Key**

- 1 flexible drive shaft
- 2 pendulum
- 3 vibration head
- 4 internal combustion engine

**Figure A.9 — Pendulum-type immersion vibrator driven by flexible drive shaft and internal combustion engine**

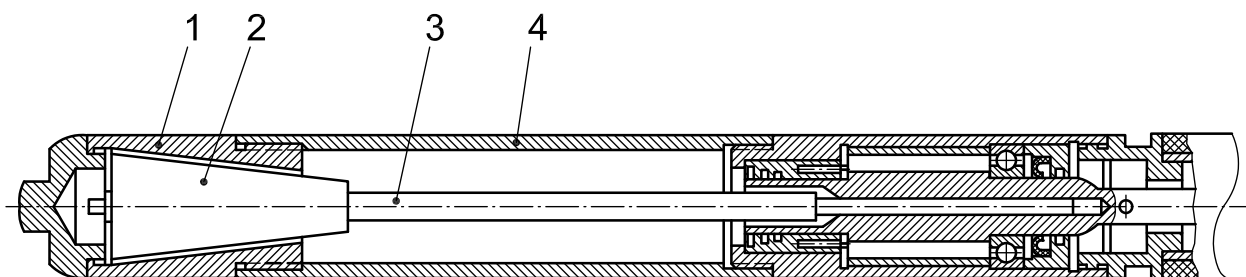

**Key**

- 1 raceway
- 2 drive unit
- 3 flexible drive shaft
- 4 housing

**Figure A.10 — Pendulum type immersion vibrator**



---

---

**ICS 91.220**

Price based on 16 pages