**Building construction machinery and
equipment — Concrete mixers —**

Part 1:

Vocabulary and general specifications

*Machines et matériels pour la construction des bâtiments — Malaxeurs
de béton —*

Partie 1: Vocabulaire et spécifications générales



Reference number
ISO 18650-1:2004(E)

© ISO 2004

PDF disclaimer

This PDF file may contain embedded typefaces. In accordance with Adobe's licensing policy, this file may be printed or viewed but shall not be edited unless the typefaces which are embedded are licensed to and installed on the computer performing the editing. In downloading this file, parties accept therein the responsibility of not infringing Adobe's licensing policy. The ISO Central Secretariat accepts no liability in this area.

Adobe is a trademark of Adobe Systems Incorporated.

Details of the software products used to create this PDF file can be found in the General Info relative to the file; the PDF-creation parameters were optimized for printing. Every care has been taken to ensure that the file is suitable for use by ISO member bodies. In the unlikely event that a problem relating to it is found, please inform the Central Secretariat at the address given below.

© ISO 2004

All rights reserved. Unless otherwise specified, no part of this publication may be reproduced or utilized in any form or by any means, electronic or mechanical, including photocopying and microfilm, without permission in writing from either ISO at the address below or ISO's member body in the country of the requester.

ISO copyright office
Case postale 56 • CH-1211 Geneva 20
Tel. + 41 22 749 01 11
Fax + 41 22 749 09 47
E-mail copyright@iso.org
Web www.iso.org

Published in Switzerland

Contents

Page

| | |
|---|-----------|
| Foreword | iv |
| Introduction | v |
| 1 Scope | 1 |
| 2 Normative references | 1 |
| 3 Terms and definitions | 1 |
| 4 Description of the basic structures of concrete mixers | 4 |
| 4.1 Basic structure of gravity mixers | 4 |
| 4.2 Basic structure of forced mixers | 4 |
| 5 Commercial specifications | 4 |
| 5.1 Basic characteristics of a concrete mixer | 4 |
| 5.2 dimensions characteristic of concrete mixers | 6 |
| 5.3 Other specifications for particular types of concrete mixers | 6 |
| Annex A (informative) Examples of concrete mixers structures and dimensional characteristics | 11 |
| Bibliography | 27 |

Foreword

ISO (the International Organization for Standardization) is a worldwide federation of national standards bodies (ISO member bodies). The work of preparing International Standards is normally carried out through ISO technical committees. Each member body interested in a subject for which a technical committee has been established has the right to be represented on that committee. International organizations, governmental and non-governmental, in liaison with ISO, also take part in the work. ISO collaborates closely with the International Electrotechnical Commission (IEC) on all matters of electrotechnical standardization.

International Standards are drafted in accordance with the rules given in the ISO/IEC Directives, Part 2.

The main task of technical committees is to prepare International Standards. Draft International Standards adopted by the technical committees are circulated to the member bodies for voting. Publication as an International Standard requires approval by at least 75 % of the member bodies casting a vote.

Attention is drawn to the possibility that some of the elements of this document may be the subject of patent rights. ISO shall not be held responsible for identifying any or all such patent rights.

ISO 18650-1 was prepared by Technical Committee ISO/TC 195, *Building construction machinery and equipment*.

ISO 18650 consists of the following parts, under the general title *Building construction machinery and equipment — Concrete mixers*:

— *Part 1: Vocabulary and general specifications*

A Part 2 dealing with the procedures for examination of the mixing efficiency is in preparation.

Introduction

This International Standard deals with concrete mixers used either as individual machines on building sites or as components of batching plants.

The document provides the terms, definitions and commercial specifications for the subject machines.

The definitions refer to whole machines, their structures and parameters.

The commercial specifications establish technical characteristics of the whole machines and their components. Enclosed figures explain structures and dimensions characteristic of the concrete mixers.

Building construction machinery and equipment — Concrete mixers —

Part 1: Vocabulary and general specifications

1 Scope

This International Standard establishes additional terms and definitions to describe the functioning and the required and optional components for various types of concrete mixers. The content of commercial literature specifications for these types of machines is defined.

It applies to concrete mixers as defined in ISO 11375, truck mixers excluded.

2 Normative references

The following referenced documents are indispensable for the application of this document. For dated references, only the edition cited applies. For undated references, the latest edition of the referenced document (including any amendments) applies.

ISO 11375:1998, *Building construction machinery and equipment — Terms and definitions*

3 Terms and definitions

For the purposes of this document, the terms and definitions given in ISO 11375 and the following apply.

3.1

pan-type concrete mixer

compulsory mixer with agitators rotating about the vertical axis of a stationary or rotating pan

3.2

charging time

t_1

duration of charging the concrete components to the mixer for one batch

NOTE 1 Refers to batch-type concrete mixers.

NOTE 2 The charging time, t_1 , is expressed in units of seconds.

3.3

mixing time

t_2

(batch-type mixer) duration from the completion of charging the concrete components to the completion of their mixing

NOTE The mixing time, t_2 , is expressed in units of seconds.

3.4 mixing time

t_2
(continuous mixer) duration during which the concrete components are kept in the mixing chamber

NOTE 1 The mixing time for a continuous mixer is calculated as follows:

$$t_2 = \frac{m_c}{q_m}$$

where

m_c is the mass of concrete components in the mixing chamber, expressed in kilograms;

q_m is the mass flow rate of the concrete components being charged, expressed in kilograms per second.

NOTE 2 The mixing time, t_2 , is expressed in units of seconds.

3.5 discharging time

t_3
duration from the start of discharging to its completion

NOTE 1 The remainder in the mixer after discharging is expected not exceed 3 %.

NOTE 2 The discharging time, t_3 , is expressed in units of seconds.

3.6 reset time

t_4
duration from the completion of the discharging to the start of charging for the next batch

NOTE The reset time, t_4 , is expressed in units of seconds.

3.7 cycle time

t_c
duration from the start of charging concrete components to the completion of preparation to accept the next charge after the reset

NOTE 1 The cycle time is calculated from the following equation: $t_c = t_1 + t_2 + t_3 + t_4$.

NOTE 2 The cycle time, t_c , is expressed in units of seconds.

3.8 number of batches

n
quantity of batches of mixing per one hour

NOTE The number of batches per hour is calculated as follows:

$$n = 3\,600/t_c$$

where t_c is the cycle time, expressed in seconds.

3.9 dry-components capacity

V_c
volume of dry components (cement + aggregates) for one batch

NOTE The dry-components capacity, V_c , is expressed in units of cubic decimetres.

3.10 ready-concrete capacity

V_u
volume of ready concrete received from one batch

NOTE 1 The approximate volume of ready concrete received from one batch may be calculated from the following equation:

$$V_u = V_c \cdot \alpha$$

where

V_u is the volume of ready concrete, expressed in cubic decimetres;

V_c is the volume of dry components, expressed in cubic decimetres;

α is the coefficient equal to the ratio V_u/V_c , which, for ordinary concrete (as defined in the note in 3.11) is 0,7.

NOTE 2 The ready-concrete capacity, V_u , is expressed in units of cubic decimetres.

3.11 rated capacity

parameter equal to the dry components capacity, V_c , divided by the ready concrete capacity, V_u

NOTE Typically, concrete mixer rating capacity refers to the ordinary concrete used in building sites which has a density between 1,8 kg/dm³ and 2,5 kg/dm³ and is composed of cement, water, fine and coarse mineral aggregates and possibly mineral additives and chemical admixtures. In the case of special concrete mixes (e.g. heavy aggregates), it is necessary that the concrete mixer capacity value be agreed between the supplier and purchaser.

EXAMPLE If the dry-components capacity for a mixer is 500 dm³ and the ready-concrete capacity is 350 dm³, then the rated capacity is 500/350.

3.12 theoretical output capacity

Q
number of cubic metres of ready concrete received from the mixer per hour of operation

NOTE 1 The theoretical output for a batch type concrete mixer is expressed by the equation:

$$Q = n \times V_u / 1\,000$$

where

n is the number of batches per hour;

V_u is the capacity of ready concrete, expressed in cubic decimetres.

NOTE 2 The theoretical output capacity for a continuous mixer is calculated as follows:

$$Q = \frac{3,6 \times q_m}{\rho}$$

where

q_m is the mass flow rate of charging concrete components, expressed in kilograms per second;

ρ is the specific gravity of the produced concrete components, expressed in kilograms per cubic decimetre.

NOTE 3 The theoretical output capacity, Q , is expressed in units of cubic metres per hour.

4 Description of the basic structures of concrete mixers

4.1 Basic structure of gravity mixers

Gravity mixers (see Figures A.1 to A.5) consist of the following basic units: an electric motor or combustion engine, a mixing drum, a mixing drum transmission, and a tipping drum mechanism and supporting frame, which may be provided with wheels to aid relocation. The bigger machines (with a capacity larger than approximately 350 dm³) typically have a skip hoist or charging bucket, a water-dosing unit and a towbar (see Figures A.3, A.4 and A.5).

4.2 Basic structure of compulsory mixers

Compulsory mixers (see Figures A.6 to A.14) consist of the following basic units: a pan or trough, mixing blades, an electric motor and transmission for the mixing-blades drive, a discharging gate and its drive. Bigger machines (with a capacity larger than approximately 350 dm³) are typically equipped with a charging skip hoist, a cover for the pan or trough and a water-distributing installation (see Figures A.7, A.8, A.10 and A.14). For easy relocation, the machines may be provided with wheels.

5 Commercial specifications

5.1 Basic characteristics of a concrete mixer

5.1.1 General data

Specify the following parameters in the designated units, where given:

- | | |
|---|-------------------|
| a) general type, e.g. tipping drum, reversing drum, discharging chute, turbo, planetary, turbo-planetary, counter-current operation, concurrent operation, with high-speed stirrer and paddle concrete mixer; | |
| b) rated capacity | dm ³ |
| c) output per hour for a specified number of cycles, <i>n</i> ¹⁾ | m ³ /h |
| d) maximum size of aggregates: | |
| — gravel | mm |
| — crushed stone | mm |
| e) total power installed | kW |
| f) mass of the base machine | kg |
| g) mass of the unloaded machine in operating mode | kg |
| h) overall dimensions during operation: | |
| — length | mm |
| — width | mm |
| — height | mm |

1) This parameter designates the technical capability of a mixer and usually refers to ordinary concrete (as defined in the note to 3.11) production. Some concrete mixes (e.g. with a low water/cement ratio used in the precast-concrete industry) may require a prolonged mixing time. In these cases, it is necessary that the mixer's output capacity be agreed between the purchaser and supplier.

5.1.2 Detailed data for the concrete-mixer components

5.1.2.1 Motors and engines for mixing mechanisms

Specify whether the unit is driven by an electric motor or a combustion engine, and the relevant information from the following:

a) electric motors:

- number of phases
- supply voltage V
- power kW
- frequency Hz
- revolutions min^{-1}

b) combustion engines:

- type:
 - i) 4-stroke petrol
 - ii) 2-stroke petrol
 - iii) diesel
- power kW
- revolutions min^{-1}

5.1.2.2 Skip hoist or bucket with optional specifications

Specify the following:

- a) skip-hoist or bucket capacity dm^3
- b) speed of lifting and descending m/min
- c) time of lifting and descending (for charging bucket) s
- d) mass of the skip hoist or bucket assembly kg

5.1.2.3 Hydraulic or pneumatic installation for tilt mechanism

Specify the following:

- a) capacity of the hydraulic pump or compressor l/min
- b) maximum pressure (gauge) MPa
- c) volume of the hydraulic oil tank or air tank dm^3

5.1.2.4 Water dosing installation with optional specifications

Specify the following:

- a) water-supply pressure MPa
- b) water-pump capacity l/min
- c) internal diameter of water supply line mm
- d) type of water-supply unit:
 - flow type with flow meter
 - volume type with water tank
 - weighing type with scale
- e) operating capacity of water-supply unit l

5.2 Dimensions characteristic of concrete mixers

The following dimensions, characteristic of concrete mixers and required for their installation and operation, shall be provided:

- a) overall dimensions (length, width and height) in operating mode and prepared for relocation (the latter pertains to a mixer provided with wheels);
- b) maximum angle of inclination of the mixing drum in operation (pertains to tipping-drum concrete mixers);
- c) dimensions and location of charging and discharging holes, including the slewing angle, δ , for the discharging gate;
- d) dimensions of the skip hoist or charging bucket assembly;
 - width and length of the skip-hoist track;
 - overall dimensions of the ship hoist and bucket;
- e) location of the charging skip hoist relative to the drum or pan;
- f) dimensions of the pan and its cover (diameter, height);
- g) spacing of mounting holes (pertains to stationary mixers).

Examples of characteristic dimensions of concrete mixers are presented in Figures A.1 to A.6 and A.8 to A.14.

5.3 Other specifications for particular types of concrete mixers

NOTE These characteristics augment the data given in 5.1.

5.3.1 Tipping drum gravity concrete mixer

See Figures A.1, A.2 and A.3.

Specify the following:

- a) revolutions of the drum min⁻¹
- b) method of additional protection from electric shock (2-class isolation, residual current device (RCD), separating transformer, etc.)
- c) permissible hauling speed: km/h
- d) type of tilting mechanism:
 - manual:
 - i) hand lever with drum position locking
 - ii) hand wheel with: direct drum position locking, brake disc or pedal operated of a drum position locking
 - pneumatic
 - hydraulic
- e) type and dimension of wheels:
 - iron
 - elastic
 - solid-rubber tires
 - pneumatic tires
 - for dimensions, see 5.2 and Figures A.1, A.2 and A.3.
- f) options:
 - car or truck towbar, mudguards, lighted licence plate and spring-mounted axle for towing up to 80 km/h
 - drum cover for horizontal mixing
 - washer for the drum cover

5.3.2 Reversing-drum concrete mixer

See Figures A.4 and A.5.

Specify the following:

- a) number of revolutions of the drum min⁻¹
- b) permissible hauling speed km/h
- c) for dimensions, see 5.2 and Figures A.4 and A.5
- d) options:
 - scraping shovel
 - water-supply equipment (flow meter or volumetric gauging unit to measure water delivery)
 - skip-hoist weighing system

5.3.3 Pan-type concrete mixers

See Figures A.6, A.7, A.8, A.9 and A.10.

5.3.3.1 General data

Specify the following:

- a) method of discharging of the mixer:
 - rotary or sliding gate, either actuated manually or driven electro-mechanically, hydraulically or pneumatically
 - drop gate located in the centre of the pan bottom
 - by tipping of the mixer
- b) method of suspension of the mixing blade arms:
 - rigid
 - elastic
- c) control:
 - push-button contacts in switchbox
 - for dimensions, see 5.2 and Figures A.8 and A.10²⁾
 - options for the charging skip-hoist assembly, supporting the structure, metering the water flow, including a dirt-trap and a stop valve, volumetrically metering the water-supply unit, and weighing units for the cement and aggregates.

5.3.3.2 Turbo mixer

See Figures A.6, A.7 and A.8.

Specify following:

- a) mixing-blade assembly:
 - number of revolutions of the rotor min⁻¹
 - number of mixing blades
 - number of scraper cleaning blades for the side surfaces of the pan
- b) for dimensions, see 5.2 and Figure A.8

2) Due to the variety of pan-type concrete mixers, only two examples of the characteristic dimensions are given. These are turbo and planetary mixers, which are mostly used ones.

5.3.3.3 Planetary and turbo-planetary mixer

See Figures A.9 and A.10.

Specify the following:

a) mixing-blade assembly:

- number of revolutions of the planetary gear min^{-1}
- number of revolutions of the mixing star(s) min^{-1}
- number of mixing stars
- number of blades for the single mixing stars
- number of the scraper cleaning blades for the pan surface
- number of working blades in the turbo system

b) for dimensions, see 5.2 and Figure A.10.

5.3.3.4 Counter-current and concurrent operation mixers

Specify the following:

a) mixing-blade assembly:

- number of revolutions of the pan min^{-1}
- number of revolutions of the mixing star min^{-1}
- number of mixing stars
- number of blades per single mixing star
- number of the scraper cleaning blades for the pan surface

b) for dimensions, see 5.2

5.3.3.5 Concrete mixer with (a) high-speed stirrer(s)

Specify the following:

a) mixing-blade assembly:

- number of stirrers;
- number of revolutions of the stirrer min^{-1}

b) for dimensions, see 5.2

5.3.4 Paddle mixer

See Figures A.11, A.12, A.13 and A.14.

- a) type of the mixer:
 - one-paddle agitator
 - two-paddle agitators
 - number of revolutions of the paddle agitators min⁻¹
- b) method of discharging:
 - by opening of the segment of the trough bottom
 - by tipping (deals with small-sized paddle mixers)
 - dimensions
- c) for dimensional characteristic of paddle mixers, see 5.2 and Figures A.13 and A.14
- d) options for the charging skip hoist and for the water-supply installation comprised of the water-supply unit and the cut-off valve.

5.3.5 Continuous-type concrete mixer

See Figures A.15 and A.16.

Specify the following:

- a) type of mixer:
 - gravity mixer
 - compulsory mixer (with one or two paddle agitators)
- b) output capacity m³/h
- c) maximum size of aggregates:
 - gravel mm
 - crushed stone mm
- d) power installed kW
- e) motor or engine characteristics (in accordance with 5.1.2.1)
- f) mass kg
- g) for dimensions characteristic of the continuous-type concrete mixers, see 5.2 and Figures A.15 and A.16.

Annex A (informative)

Examples of concrete mixers structures and dimensional characteristics

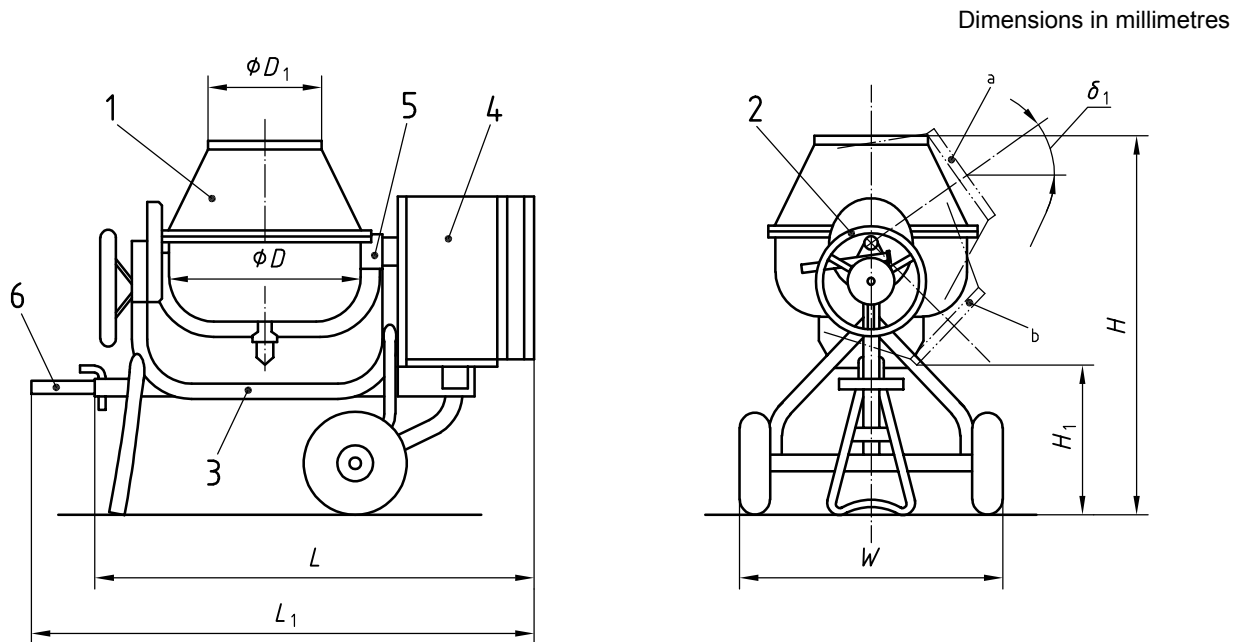

Key

- 1 mixing drum
- 2 tipping mechanism with internal tooth gear and lock for the drum position
- 3 frame and running wheels
- 4 motor with belt transmission and electrical installation
- 5 bevel gear pair
- 6 towbar

- D diameter of the mixing drum
- D_1 diameter of the charging hole
- H overall height
- H_1 height of discharging
- δ_1 angle of inclination of the mixing drum during operation, in degrees
- L overall length
- L_1 overall length in travelling position
- W overall width
- a Position for charging and mixing.
- b Position for discharging.

Figure A.1 — Small-sized tipping-drum concrete mixer equipped with travelling wheels

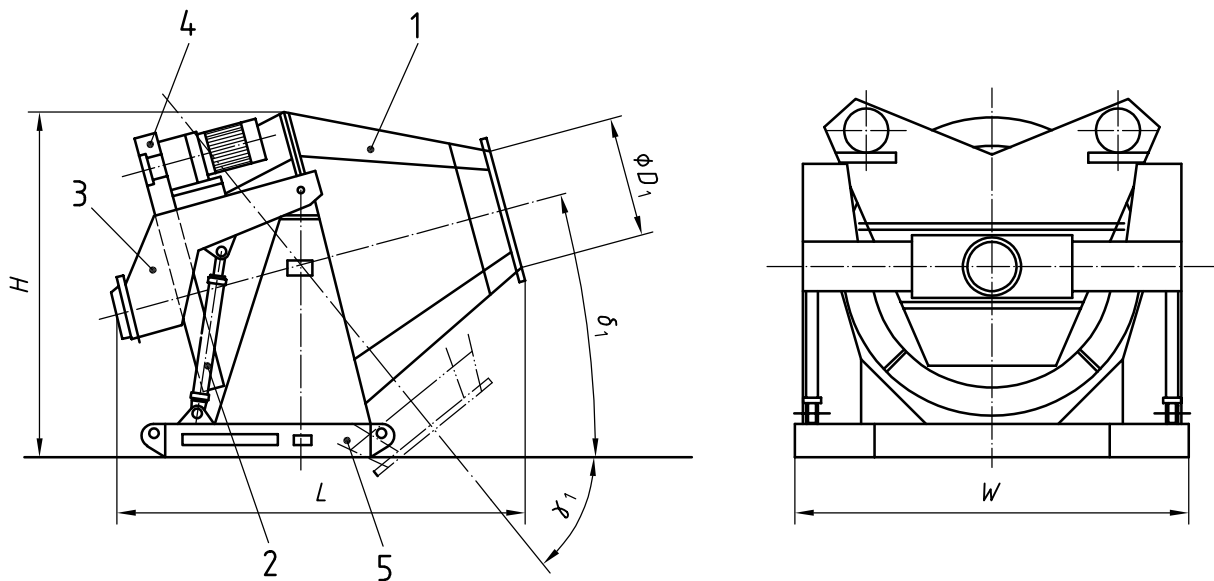

Key

- 1 mixing drum
- 2 tipping mechanism
- 3 yoke
- 4 drive unit
- 5 frame

- D_1 diameter of the charging hole
- δ_1 angle of inclination of the mixing drum during operation
- γ_1 discharge angle
- L overall length
- W overall width
- H overall height

Figure A.2 — Tipping-drum stationary concrete mixer

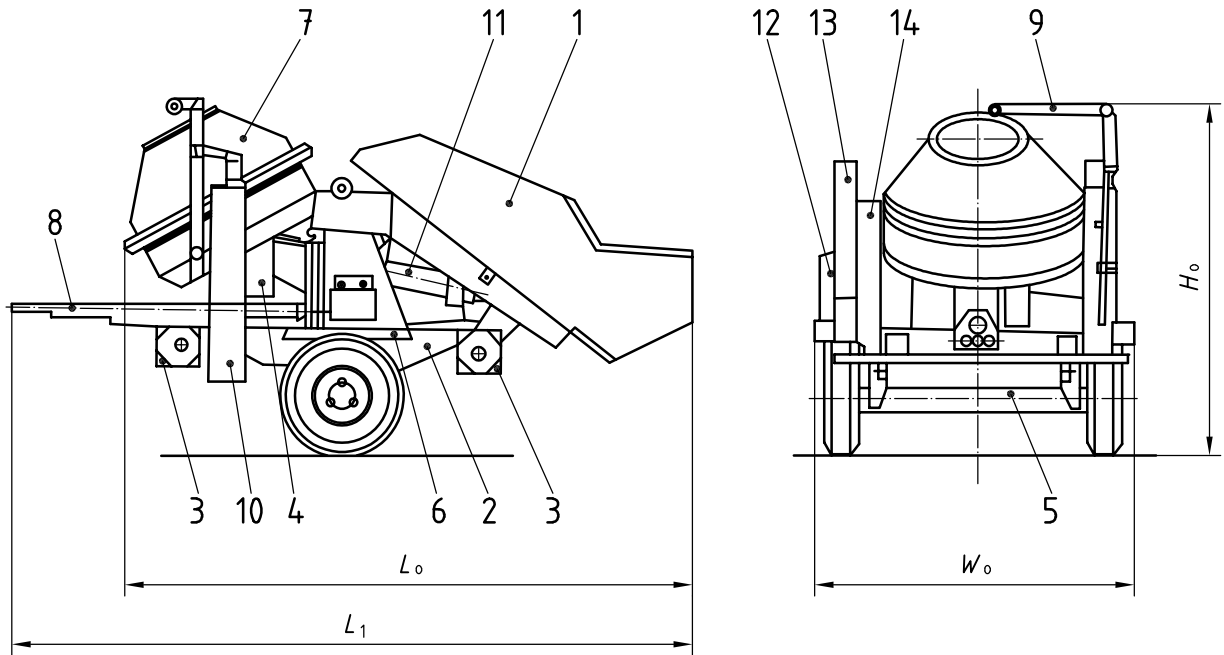
**Key**

- 1 charging bucket
- 2 chassis
- 3 front and rear supports
- 4 electric installation
- 5 axle
- 6 side support
- 7 mixing drum
- 8 towbar
- 9 water-supply installation
- 10 tipping mechanism
- 11 hydraulic drive
- 12 controls
- 13 guard
- 14 support for mixing drum

- H_o overall height in operating mode
- L_o overall length in operating mode
- L_1 overall length in transport position
- W_o overall width in operating mode

Figure A.3 — Tipping-drum concrete mixer with an hydraulic drive for the drum and the skip charging bucket

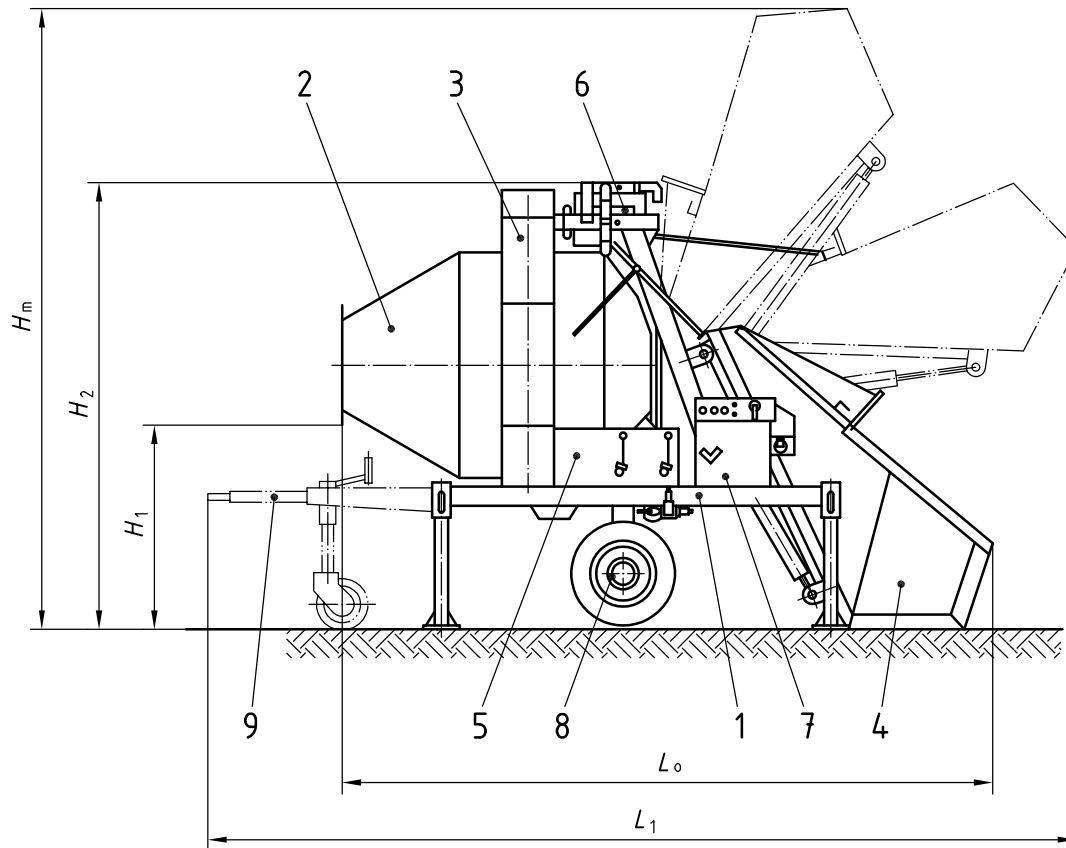

Key

- 1 frame
- 2 mixing drum
- 3 guard for the crown gear
- 4 charging bucket
- 5 hydraulic drive
- 6 water supply
- 7 electrical control panel
- 8 axle
- 9 towbar with mounting jack

- H_m maximum height
- H_1 height in discharging
- H_2 height of transport position
- L_0 length in operating mode
- L_1 length in transport position

Figure A.4 — Reversing-drum concrete mixer with hydraulically driven mixing drum and charging bucket

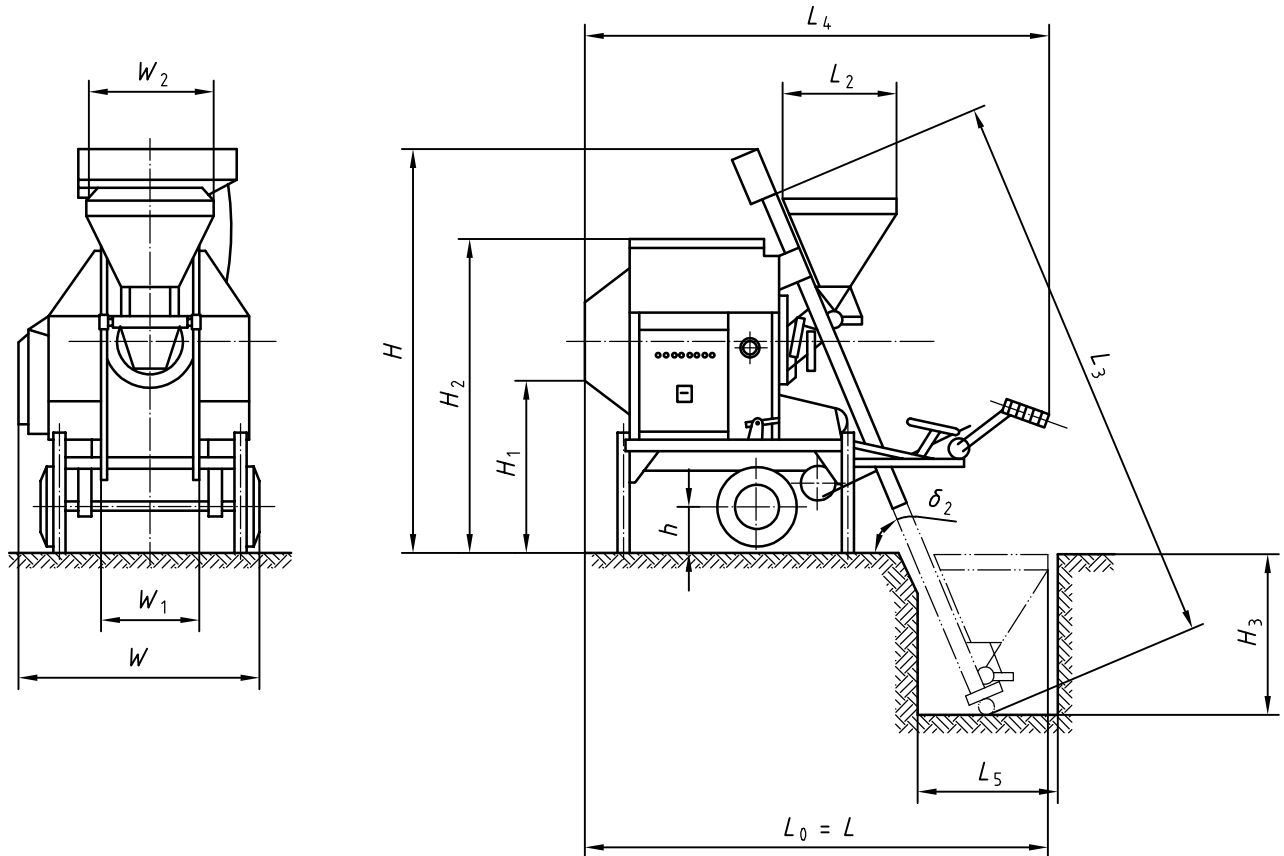

Key

- L_0 length in operating mode
- L_2 length of the charging skip hoist
- L_3 length of the skip-hoist track
- L_4 length from the head of the mixing drum to the mechanical shovel connection
- L_5 length of the hole for the charging skip hoist
- W_1 width of the skip-hoist track
- W_2 width of the charging skip hoist
- H_1 height of discharging
- H_2 height
- H_3 height of the hole for the charging skip
- h distance from the transport axle to the ground
- δ_2 angle of inclination of the track
- L overall length
- W overall width
- H overall height

Figure A.5 — Reversing-mixing-drum concrete mixer with a mechanical drive for the drum and the skip hoist

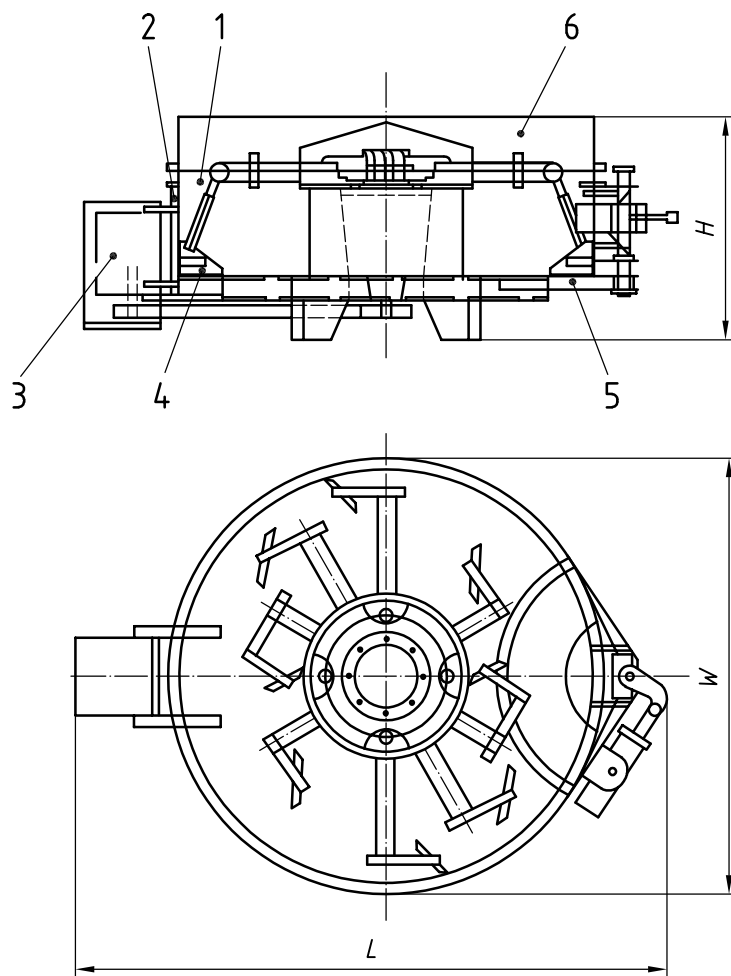

Key

- 1 pan
- 2 lining
- 3 drive unit
- 4 mixing blades
- 5 discharging gate
- 6 cover for the pan

- L overall length
- W overall width
- H overall height

Figure A.6 — Turbo concrete mixer

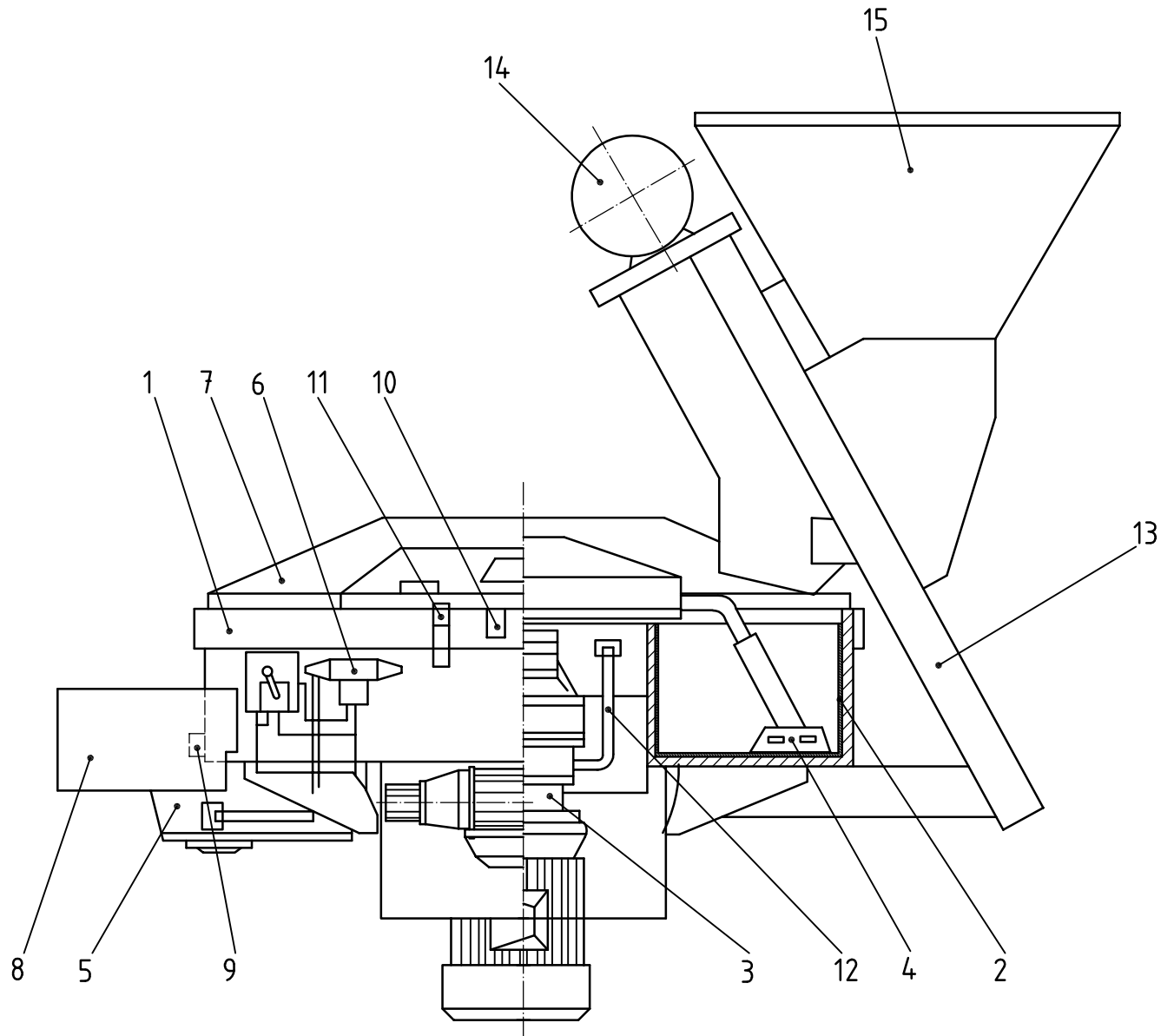

Key

- 1 pan
- 2 lining
- 3 drive unit
- 4 mixing blades
- 5 discharging gate
- 6 hydraulic drive assembly for the discharging gate
- 7 pan cover
- 8 guard for the discharging gate
- 9 limit switches for the discharging gate
- 10 safety cut-out switch for the cover of the pan
- 11 water nozzle
- 12 oil-filling inlet
- 13 track
- 14 hoisting winch
- 15 charging skip hoist

Figure A.7 — Structure of a turbo-mixer with a charging skip hoist

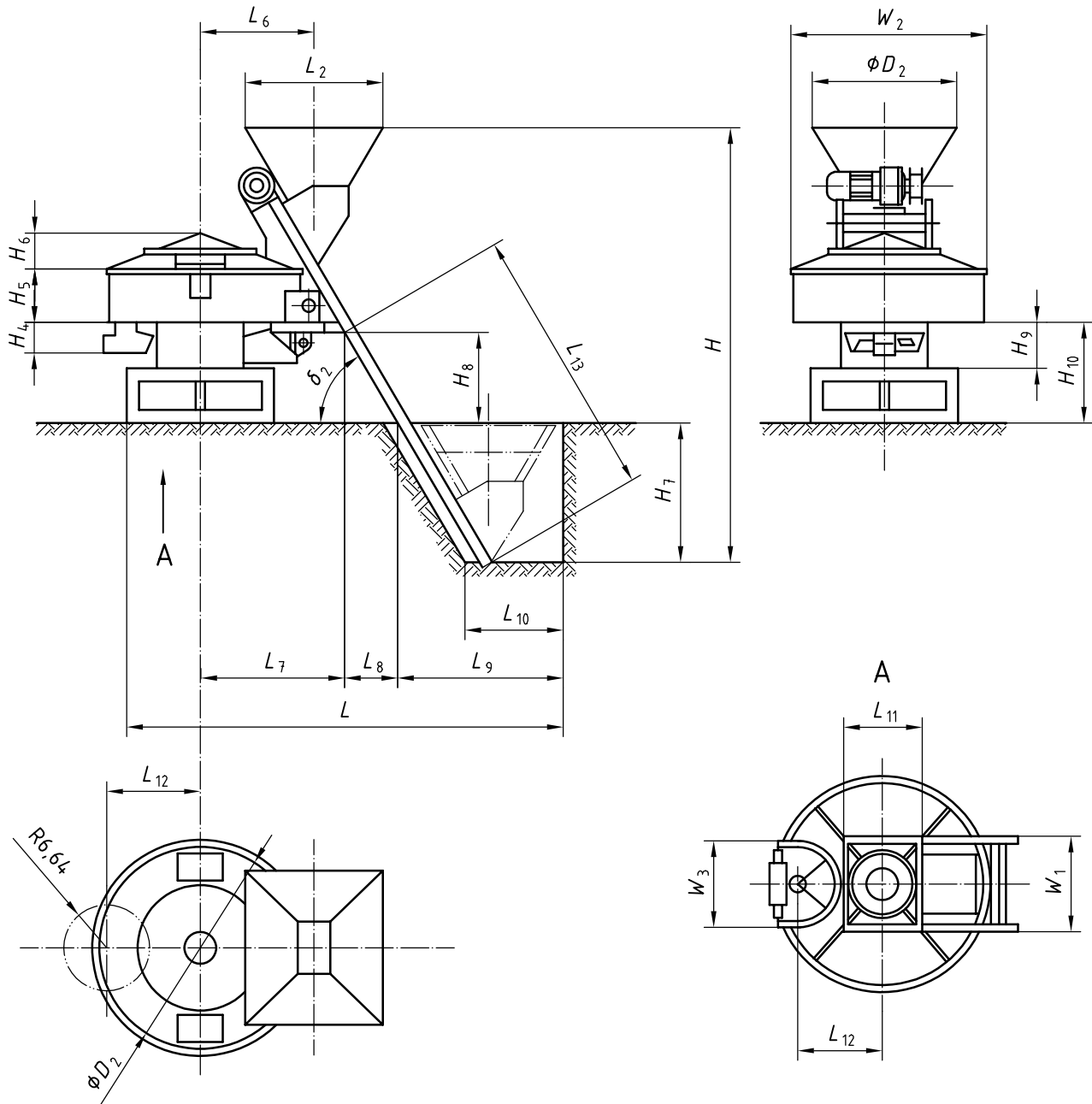

Key

- | | |
|--|--|
| H overall height | L_6 distance between axles of the mixer and skip hoist in its discharging position |
| H_4 height of discharging unit assembly | L_7 distance between the axle of the mixer and track support |
| H_5 height of the pan | L_8 distance between the track support and the track entrance to the hole |
| H_6 height of the cover | L_9 distance between the track entrance to the hole and its rear wall |
| H_7 height of the hollow for the skip hoist | L_{10} length of the bottom of the hole |
| H_8 distance between the support of the track and ground | L_{11} length of the housing of the mixing-unit drive |
| H_9 height of the housing of the mixing unit drive | L_{12} distance between the axes of the discharging gate and the mixer |
| H_{10} distance between the pan and ground | L_{13} length of the lower part of the track |
| D_2 diameter of the pan | W_1 width of the skip hoist |
| R radius of slewing of the discharging gate | W_2 width of the track |
| L overall length | W_3 width of the housing of the mixing-unit drive |
| L_2 length of the skip hoist | δ_2 angle of inclination of the track |

Figure A.8 — Dimensional characteristics of the turbo mixer

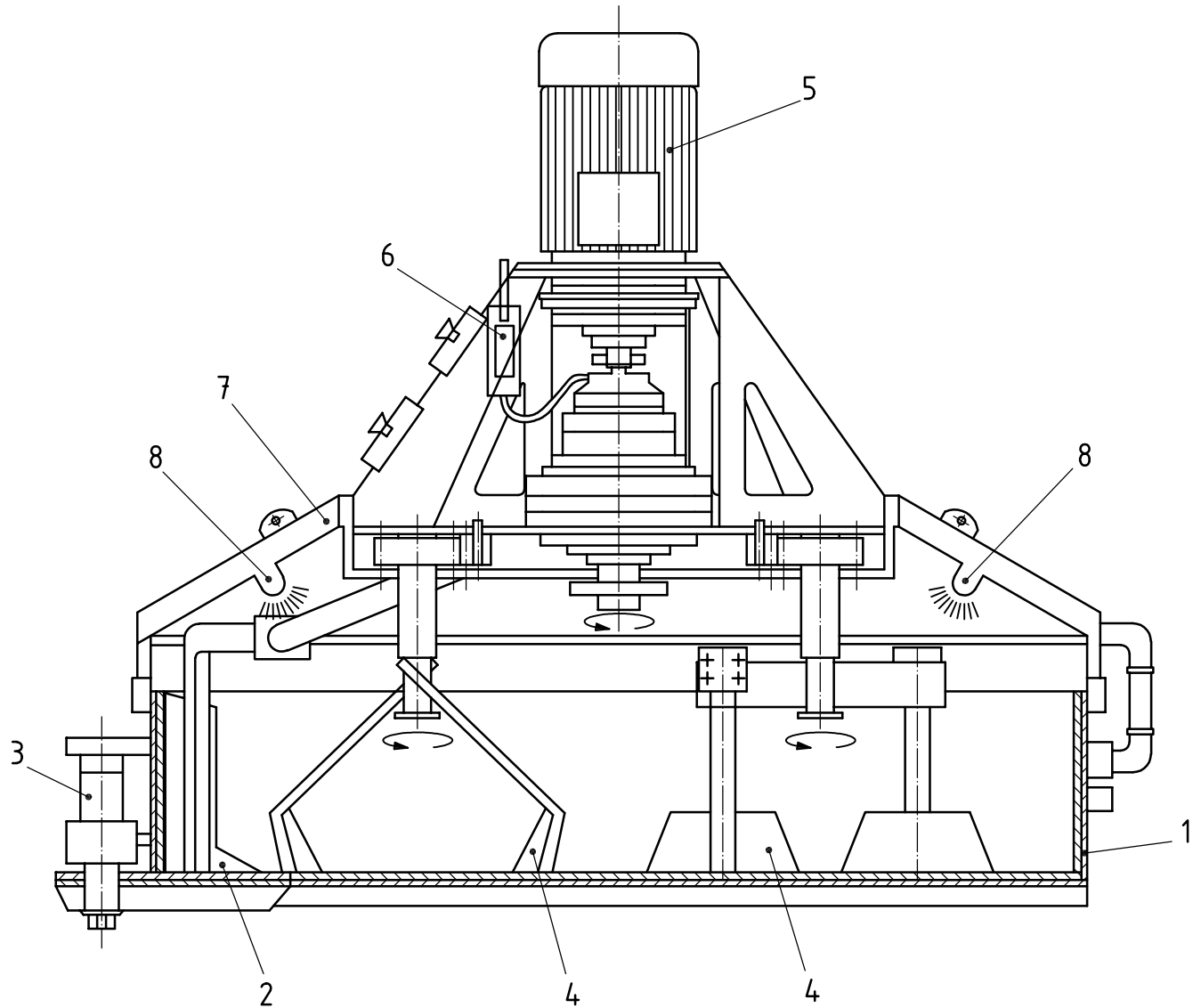
**Key**

- 1 pan
- 2 cleaning blade
- 3 hydraulic drive for the discharging gate
- 4 mixing blades for planetary movement
- 5 drive unit for the mixing blades
- 6 electrical control system
- 7 pan cover
- 8 water nozzle

Figure A.9 — Structure of the planetary concrete mixer

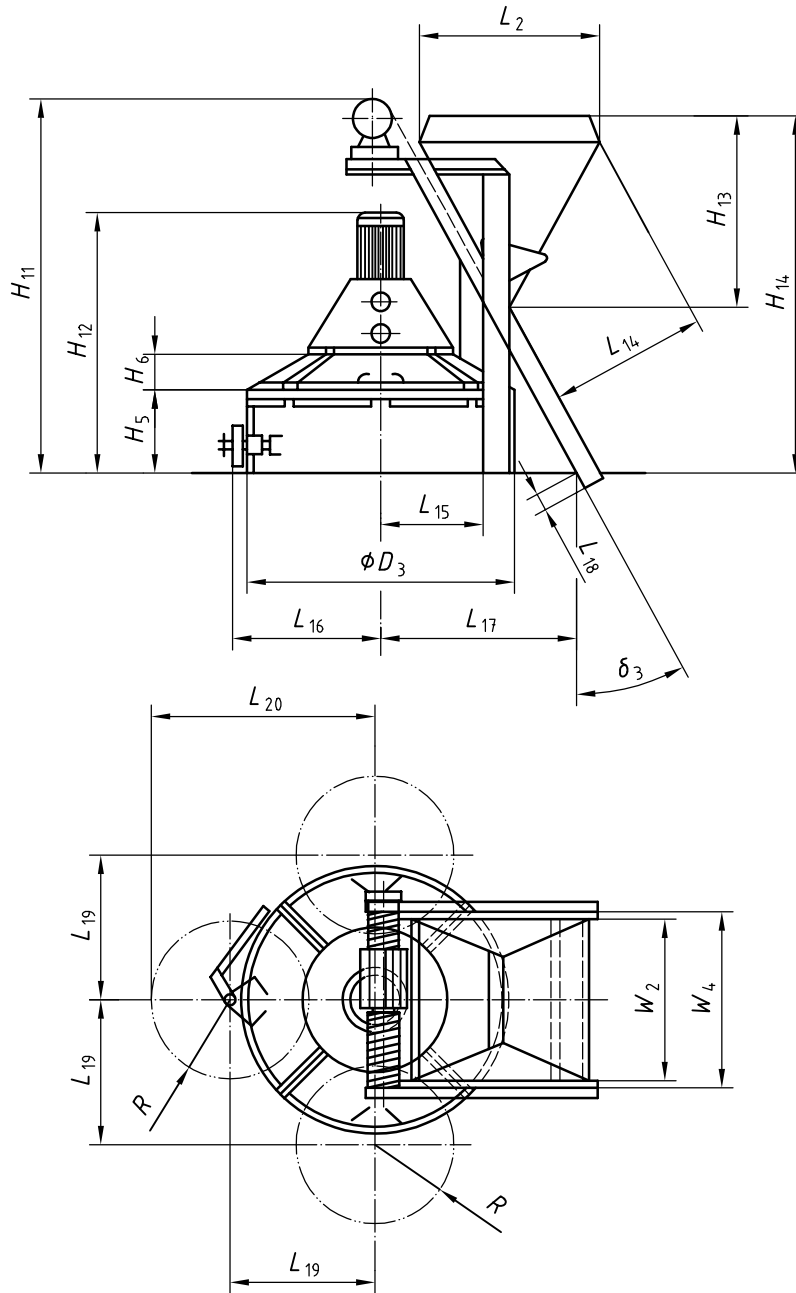

Key

- | | |
|--|--|
| H_5 height of the pan | L_{17} distance from the track to the mixer's axis measured at the mixer's base plane |
| H_6 height of the pan's cover | L_{18} length from lower part of the track measured to the mixer's base plane |
| H_{11} height from pan support to the skip-hoist winch | L_{19} distance between the mixer's and the discharging gate axes |
| H_{12} height of the mixer | L_{20} maximum distance between discharging gate in its open position and the mixer's axis |
| H_{13} height of the skip hoist | R slewing radius of the discharging gate |
| H_{14} distance between the mixer base and skip-hoist upper edge | W_2 width of the skip hoist |
| D_3 outer diameter of the pan | W_4 inner width of the track |
| L_2 length of the skip hoist | δ_3 angle of inclination of the skip hoist track |
| L_{14} distance from the skip-hoist outer edge to the track | |
| L_{15} distance from the track-supporting structure to the mixer's axis | |
| L_{16} distance from the discharging gate driving unit to the mixer's axis | |

Figure A.10 — Dimensions characteristic of the planetary mixer with charging skip hoist and three possible gates for discharging

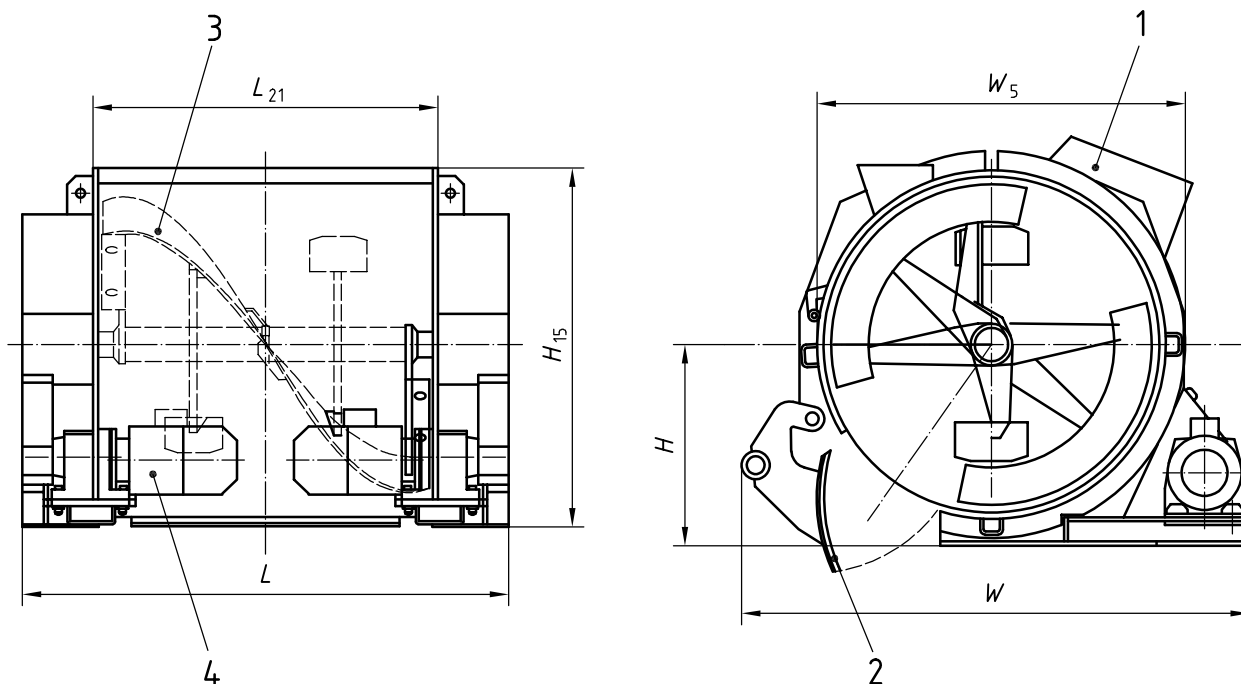

Key

- 1 aggregate inlet
- 2 discharging gate
- 3 mixing system with two helices and blades
- 4 gear motor and chain transmission for mixing system drive

- L overall length
- W overall width
- H overall height
- H_{15} height of the shaft measured from the mixer's base
- L_{21} length of the trough
- W_5 width of the trough

Figure A.11 — Paddle mixer with a single paddle agitator

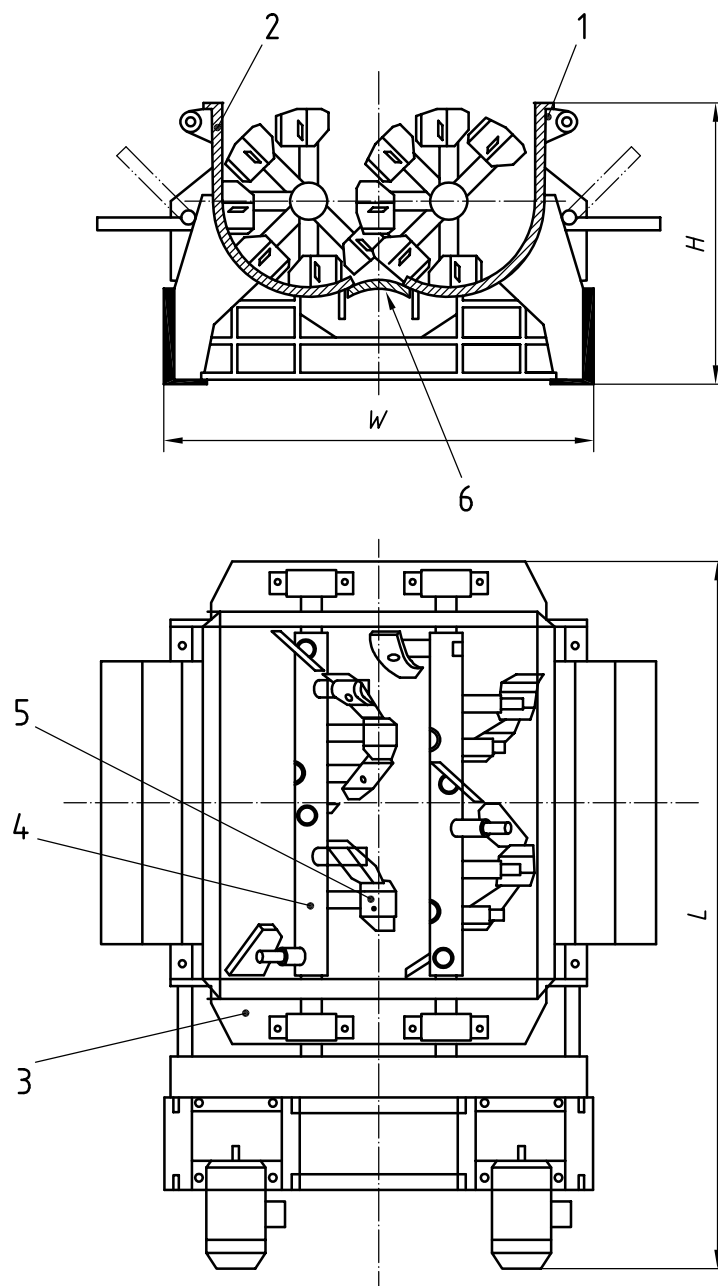

Key

- 1 trough
- 2 lining
- 3 drive unit
- 4 shaft and arms
- 5 mixing blades
- 6 discharging gate

- L* overall length
- W* overall width
- H* overall height

Figure A.12 — Paddle mixer with two-paddle agitators

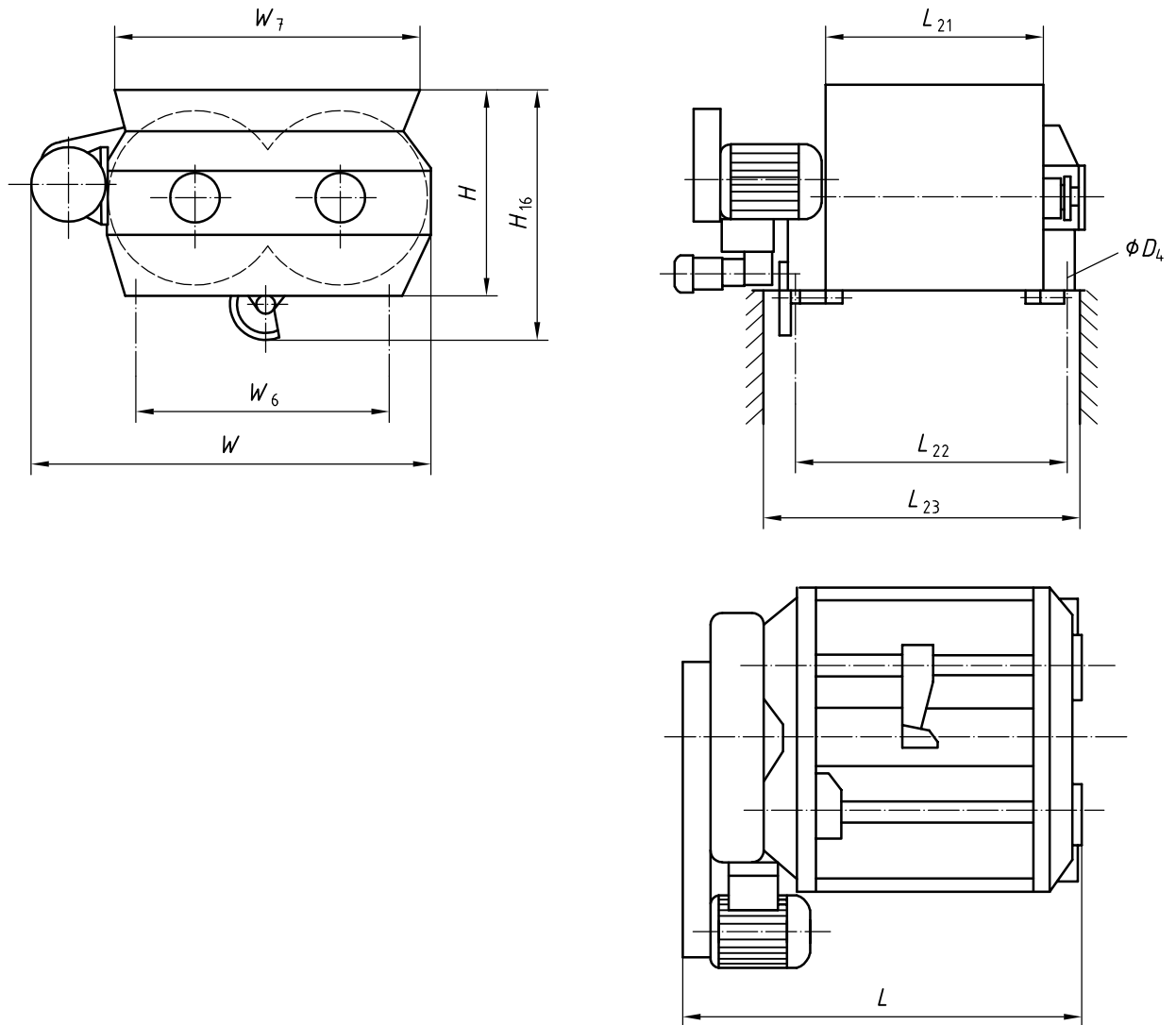

Key

- L overall length
- L_{21} length of the trough
- L_{22}, W_6 distances between the axes of the mounting holes
- L_{23} required distance for discharging
- W overall width
- W_7 width of the upper edge of the trough
- H overall height of the mixer
- H_{16} height of the mixer in discharging position
- D_4 diameter of the mounting holes

Figure A.13 — Paddle mixer (characteristic dimensions)

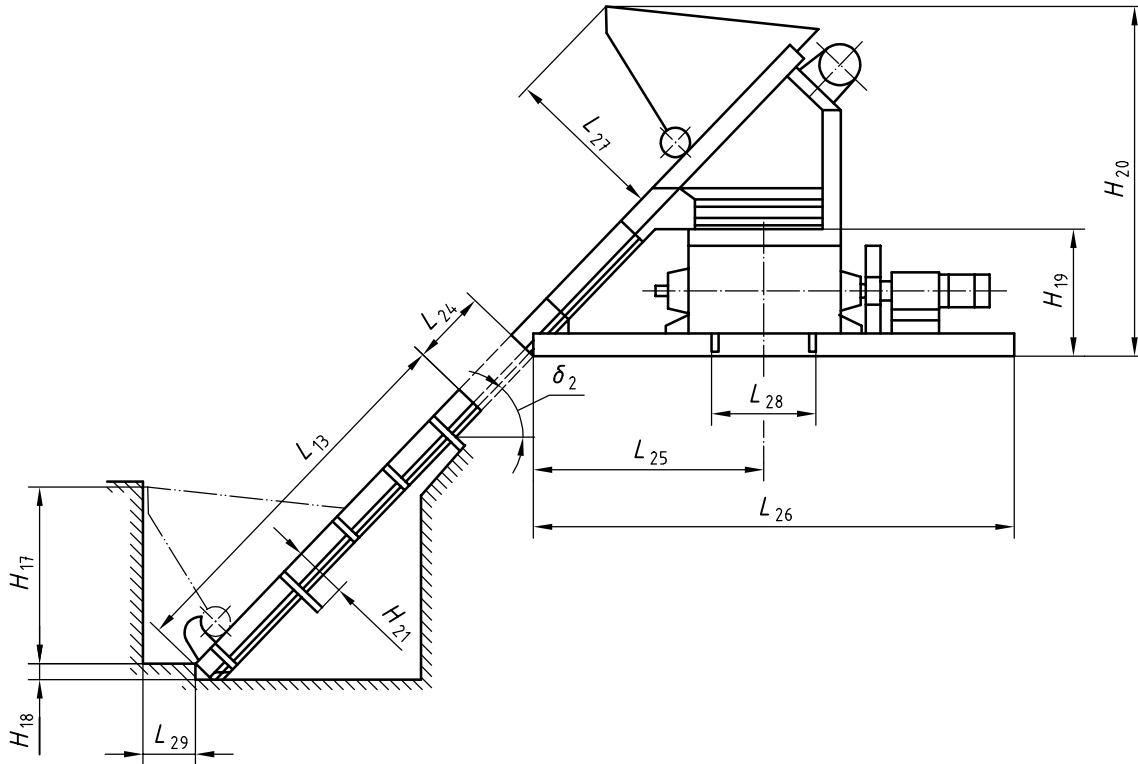

Key

- H_{17} height of the excavation for the charging skip hoist
- H_{18} height of the lower track support
- H_{19} height of the trough and base frame
- H_{20} height from base frame to the upper edge of the charging skip hoist
- H_{21} height of the support of the track
- L_{13} length of the lower part of the track
- L_{24} optional length of the track relative to the height the mixer's supporting structure
- L_{25} distance from the frame edge to its axis
- L_{26} length of the frame
- L_{27} distance between the track and the upper edge of the skip hoist
- L_{28} length of the hole for discharging in the base frame
- L_{29} length of the concrete rest for the track
- δ_2 angle of inclination of the track

Figure A.14 — Paddle mixer with skip hoist for location on a supporting structure

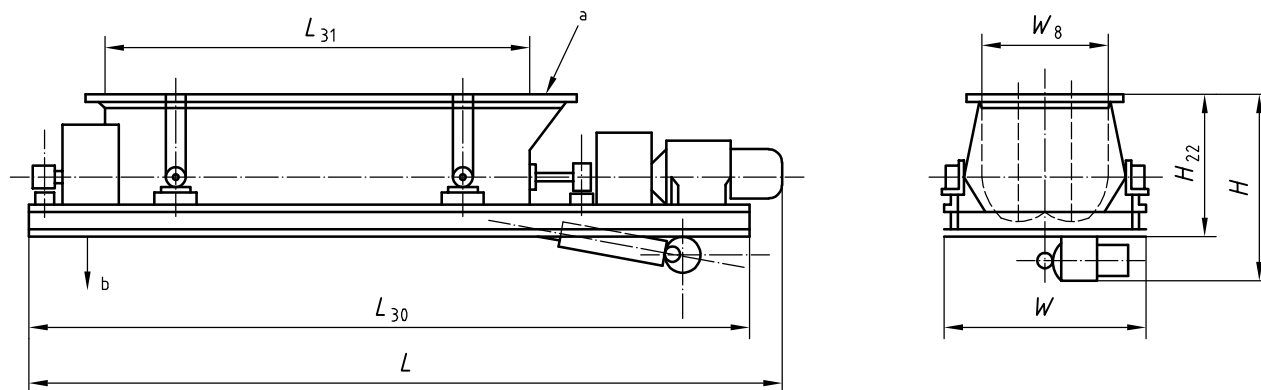
**Key** L overall length W overall width H overall height H_{22} height from the base frame to the upper edge of the trough L_{30} length of the base frame L_{31} length of the effective mixing part of the trough W_8 width of the trough

a Charging of concrete components.

b Discharging of concrete mix.

Figure A.15 — Continuous-type concrete mixer

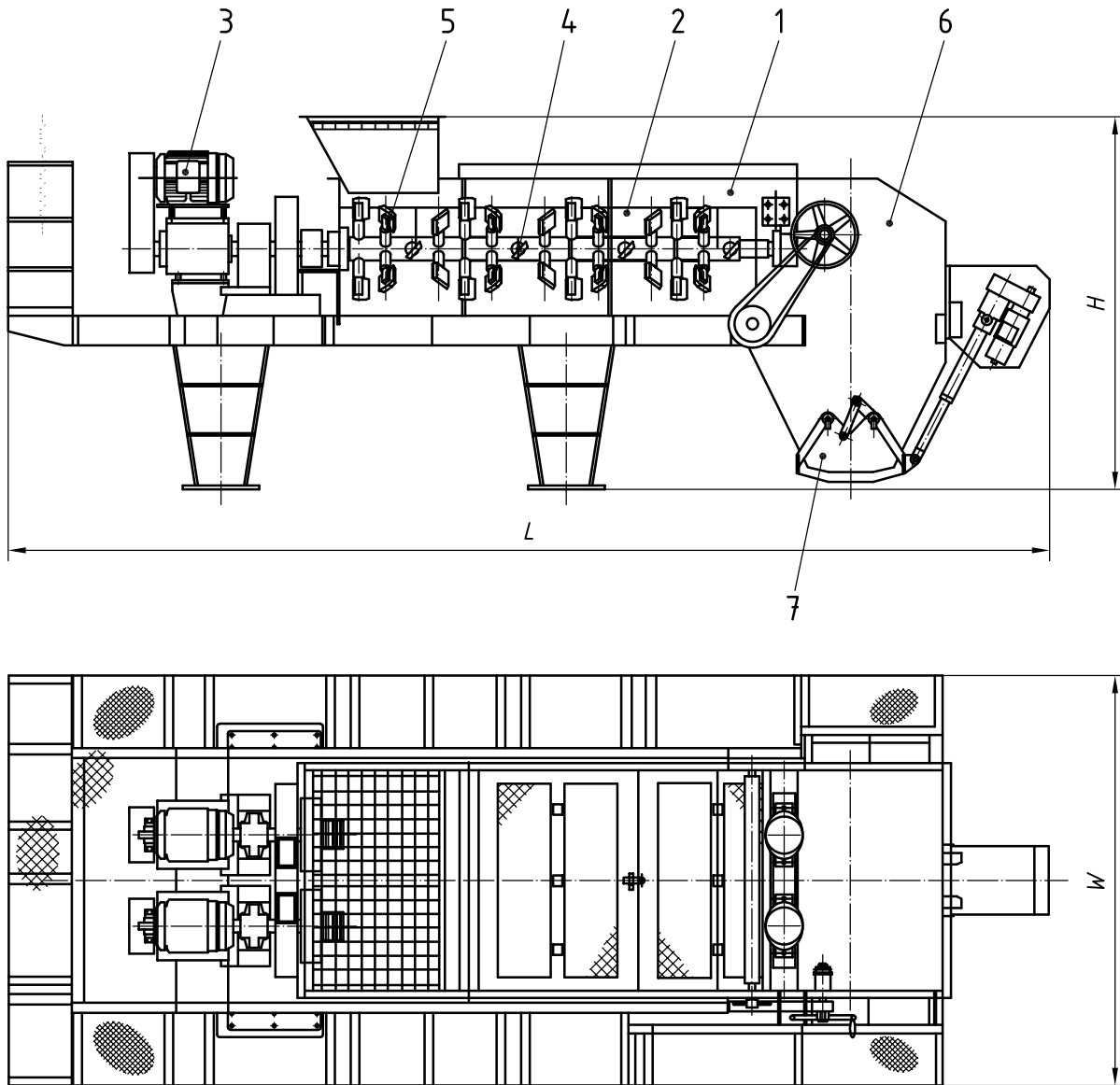

Key

- 1 trough
- 2 lining
- 3 drive unit
- 4 shaft and arms
- 5 mixing blades
- 6 discharging hopper
- 7 discharging gate

- L overall length
- W overall width
- H overall height

Figure A.16 — Continuous-type concrete mixer with two paddle agitators

Bibliography

- [1] EN 12151, *Machinery and plant for the preparation concrete and mortar — Safety requirements*
- [2] DIN 459-1, *Building material machines — Mixers for concrete and mortar — Part 1: Terms, determination of performance, sizes*

.....

ICS 01.040.91; 91.220.00

Price based on 27 pages