

---

---

**Transport packaging — Reusable,  
rigid plastic distribution boxes —**

**Part 1:  
General purpose application**

*Emballages de transport — Boîtes de distribution en plastique rigide,  
réutilisables —*

*Partie 1: Application à un besoin général*





**COPYRIGHT PROTECTED DOCUMENT**

© ISO 2016, Published in Switzerland

All rights reserved. Unless otherwise specified, no part of this publication may be reproduced or utilized otherwise in any form or by any means, electronic or mechanical, including photocopying, or posting on the internet or an intranet, without prior written permission. Permission can be requested from either ISO at the address below or ISO's member body in the country of the requester.

ISO copyright office  
Ch. de Blandonnet 8 • CP 401  
CH-1214 Vernier, Geneva, Switzerland  
Tel. +41 22 749 01 11  
Fax +41 22 749 09 47  
copyright@iso.org  
www.iso.org

# Contents

Page

<b>Foreword</b> .....	<b>iv</b>
<b>Introduction</b> .....	<b>v</b>
<b>1 Scope</b> .....	<b>1</b>
<b>2 Normative references</b> .....	<b>1</b>
<b>3 Terms and definitions</b> .....	<b>2</b>
<b>4 Types of reusable rigid plastic distribution boxes</b> .....	<b>4</b>
<b>5 Dimensions</b> .....	<b>10</b>
5.1 Plan view dimensions.....	10
5.2 Slippage prevention.....	10
5.3 Box tare mass.....	10
5.4 Nominal stacking load.....	10
<b>6 Safety</b> .....	<b>11</b>
6.1 Safety in stacking.....	11
6.2 Safety in handling.....	11
<b>7 Identification</b> .....	<b>11</b>
7.1 Unique identification of the returnable transport box.....	11
7.2 Designation of the box.....	11
<b>8 Marking and labelling</b> .....	<b>13</b>
8.1 Marking.....	13
8.1.1 Symbology requirements.....	13
8.1.2 Data requirements.....	13
8.2 Labelling.....	15
8.2.1 General.....	15
8.2.2 Labelling for parallelepipedic type of box.....	15
<b>9 Radio frequency identification (RFID)</b> .....	<b>15</b>
<b>Bibliography</b> .....	<b>16</b>

## Foreword

ISO (the International Organization for Standardization) is a worldwide federation of national standards bodies (ISO member bodies). The work of preparing International Standards is normally carried out through ISO technical committees. Each member body interested in a subject for which a technical committee has been established has the right to be represented on that committee. International organizations, governmental and non-governmental, in liaison with ISO, also take part in the work. ISO collaborates closely with the International Electrotechnical Commission (IEC) on all matters of electrotechnical standardization.

The procedures used to develop this document and those intended for its further maintenance are described in the ISO/IEC Directives, Part 1. In particular the different approval criteria needed for the different types of ISO documents should be noted. This document was drafted in accordance with the editorial rules of the ISO/IEC Directives, Part 2 (see [www.iso.org/directives](http://www.iso.org/directives)).

Attention is drawn to the possibility that some of the elements of this document may be the subject of patent rights. ISO shall not be held responsible for identifying any or all such patent rights. Details of any patent rights identified during the development of the document will be in the Introduction and/or on the ISO list of patent declarations received (see [www.iso.org/patents](http://www.iso.org/patents)).

Any trade name used in this document is information given for the convenience of users and does not constitute an endorsement.

For an explanation on the meaning of ISO specific terms and expressions related to conformity assessment, as well as information about ISO's adherence to the World Trade Organization (WTO) principles in the Technical Barriers to Trade (TBT) see the following URL: [www.iso.org/iso/foreword.html](http://www.iso.org/iso/foreword.html).

The committee responsible for this document is ISO/TC 122, *Packaging*.

A list of all parts in the ISO 18616 series can be found on the ISO website.

## Introduction

Standardization is a crucial element to improve the efficiency of a returnable packaging system in a supply chain and can help to integrate a supply chain. Standardization of returnable transport items (RTI) and its operation system (returnable transport system) is the first step for an efficient and seamless supply chain. RTI standards such as container sizes, materials and weights enable a company's supply chain integration. A standardized returnable packaging operation system facilitates the supply chain automation, increases efficiency of inventory control and reduces total logistics costs. Global standardization of returnable transport systems can help a company make it easy to invest in their packaging system while facilitating smooth and integrated supply chain interfaces from suppliers to customers.



# Transport packaging — Reusable, rigid plastic distribution boxes —

## Part 1: General purpose application

### 1 Scope

This document specifies the four main types of reusable, rigid plastic distribution boxes for general purpose application in the fields of handling, transport, storage and display of products in distribution systems from the point of manufacture to the point of retail services:

- a) rigid parallelepipedic and rectangular boxes (stackable boxes);
- b) foldable boxes;
- c) nestable boxes;
- d) nestable and stackable boxes.

These boxes are based on the modular area 600 mm × 400 mm, 600 mm × 500 mm, 550 mm × 366 mm and subdivisions of them. This document defines the main types of rigid plastic distribution boxes, dimensions, safety, designation, marking and labeling.

This document is designed for general purpose applications in a returnable transport system. For automotive industry application, ISO 19709-1, ISO/TS 19709-2 and ISO/TS 19709-3 can be referenced.

### 2 Normative references

The following documents are referred to in the text in such a way that some or all of their content constitutes requirements of this document. For dated references, only the edition cited applies. For undated references, the latest edition of the referenced document (including any amendments) applies.

ISO 3394, *Packaging — Complete, filled transport packages and unit loads — Dimensions of rigid rectangular packages*

ISO 3676, *Packaging — Complete, filled transport packages and unit loads — Unit load dimensions*

ISO/IEC 15418, *Information technology — Automatic identification and data capture techniques — GS1 Application Identifiers and ASC MH10 Data Identifiers and maintenance*

ISO/IEC 15434, *Information technology — Automatic identification and data capture techniques — Syntax for high-capacity ADC media*

ISO/IEC 15459-5, *Information technology — Automatic identification and data capture techniques — Unique identification — Part 5: Individual returnable transport items (RTIs)*

ISO/IEC 16022, *Information technology — Automatic identification and data capture techniques — Data Matrix bar code symbology specification*

ISO 17364, *Supply chain applications of RFID — Returnable transport items (RTIs) and returnable packaging items (RPIs)*

ISO/IEC 18000-63, *Information technology — Radio frequency identification for item management — Part 63: Parameters for air interface communications at 860 MHz to 960 MHz Type C*

## ISO 18616-1:2016(E)

ISO 18616-2, *Transport packaging — Reusable, rigid plastics distribution boxes — Part 2: General specifications for testing*

### 3 Terms and definitions

For the purposes of this document, the terms and definitions given in ISO 21067 and ISO/IEC 19762 and the following apply.

ISO and IEC maintain terminological databases for use in standardization at the following addresses:

- IEC Electropedia: available at <http://www.electropedia.org/>
- ISO Online browsing platform: available at <http://www.iso.org/obp>

**3.1  
box**  
rigid packaging with rectangular or polygonal sides, usually completely enclosing the contents

[SOURCE: ISO 21067:2007, 2.3.7]

**3.2  
bottom**  
normal standing surface of packaging

[SOURCE: ISO 11683:1997, 3.4]

**3.3  
burr**  
raised sharp edge, frequently with a wane on the opposite side

[SOURCE: ISO 8785:1998, 4.2.6]

**3.4  
capacity**  
<returnable transport systems> inner parallelepipedic rectangular volume calculated by multiplying the usable inner length by the usable inner width (both measured at the half way height) and the usable inner height

**3.5  
ends**  
vertical face of the box which corresponds to the width

[SOURCE: ISO 6780:2003, 3.7]

**3.6  
flash**  
ridge of workpiece material either expelled from the gap between mould parts or die parts when forming (die casting, forging, etc.) or formed perpendicular to the direction of pressure when resistance welding two surfaces (upset welding, flash welding, etc.)

[SOURCE: ISO 8785:1998, 4.2.7]

**3.7  
foldable box**  
box with a mechanism to reduce its volume when empty

Note 1 to entry: See examples in [Figures 1](#) and [2](#).



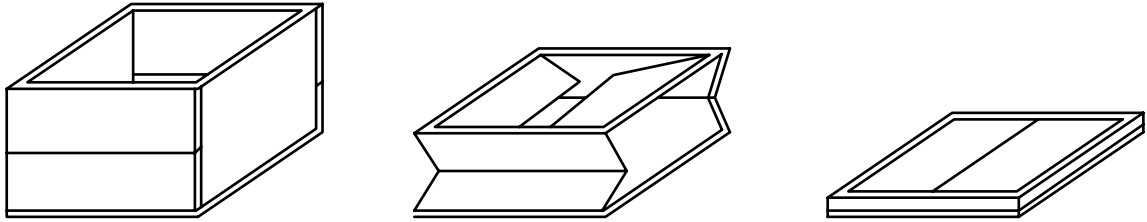
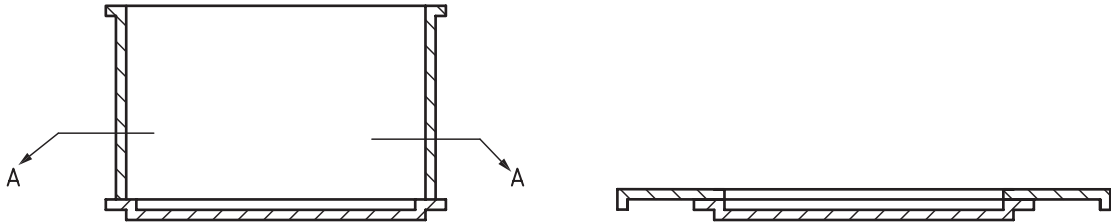

Figure 1 — Folded without plan view dimensions changed



**Key**

A Ends for interlocking.

Figure 2 — Folded with plan view dimensions changed

**3.8  
lid**

top fitting cover to enclose a working volume and to prevent the escape of material accessory which fits inside or over the top rim of the box

**3.9  
maximum capacity**

liquid equivalent volume up to the usable inner height

**3.10  
nestable box**

box which can be placed upright partly inside another when empty, to reduce volume

Note 1 to entry: See [Figure 6](#).

**3.11  
nestable and stackable box**

nestable box incorporating a method of stacking

Note 1 to entry: See [Figure 7](#).

**3.12  
nominal load**

lowest load value, for the purposes of comparison, for the specified support conditions, independent of the type of load (excluding concentrated loads)

[SOURCE: ISO 445:2013, 2.2]

**3.13  
nominal stacking load**

<returnable transport systems> recommended maximum weight applied to the top of a box when stacked

**3.14**

**reusable packaging**

packaging or packaging component which has been designed to accomplish or proves its ability to accomplish a minimum number of trips or rotations in a system for reuse

[SOURCE: ISO 21067-2:2015, 2.3.2]

**3.15**

**sides**

vertical face of the box which corresponds to the length

[SOURCE: ISO 6780:2003, 3.8]

**3.16**

**test load**

maximum load required to be contained inside the box, multiplied by the safety factor, or the maximum stacking load required on top of the box, multiplied by the safety factor

**3.17**

**intrusive marking**

**subtractive marking**

marking method designed to alter a surface to form a human- or machine-readable symbol

[SOURCE: ISO/IEC 19762:2016, 04.02.24, modified]

Note 1 to entry: This marking category includes, but is not limited to, methods that abrade, burn, corrode, cut, deform, dissolve, etch, melt, oxidize or vaporize a surface. Intrusive marking methods include stamping, laser etching, chemical etching, dot peen and micro-sandblast.

**3.18**

**non-intrusive marking**

**additive marking**

marking method designed to add material to a surface to form a human- or machine-readable symbol

[SOURCE: ISO/IEC 19762:2016, 04.02.25, modified]

Note 1 to entry: Non-intrusive marking methods include ink jet, some forms of laser bonding, liquid metal jet, screen process, stencil and thin film deposition.

**3.19**

**permanent marking**

intrusive or non-intrusive markings that are designed to remain legible for at least the normal service life of an item

[SOURCE: ISO/IEC 19762:2016, 04.02.26]

**3.20**

**returnable transport item**

**RTI**

means to assemble goods for transportation, storage, handling and product protection in the supply chain which are returned for further usage

EXAMPLE Pallets with and without cash deposits as well as all forms of reusable containers, crates, trays, boxes, roll pallets, barrels, trolleys, pallet collars and lids.

[SOURCE: ISO 17364:2013, 4.3, modified]

## **4 Types of reusable rigid plastic distribution boxes**

Details of the four main types of rigid plastic distribution boxes are given in [Table 1](#) and [Figures 3](#) to [7](#).

**Table 1 — Dimensional descriptions**

<b>Position Number</b>	<b>Description</b>
1	Overall length
2	Overall width
3	Overall height
4	Usable inner height
5	Location height
6	Stacking height
7	Overall length flat
8	Overall width flat
9	Overall height flat
10	Stacking height flat
11	Incremental height when nested
12	Inner bottom length
13	Inner bottom width
14	Inner top length
15	Inner top width
16	Usable inner bottom length
17	Usable inner top length

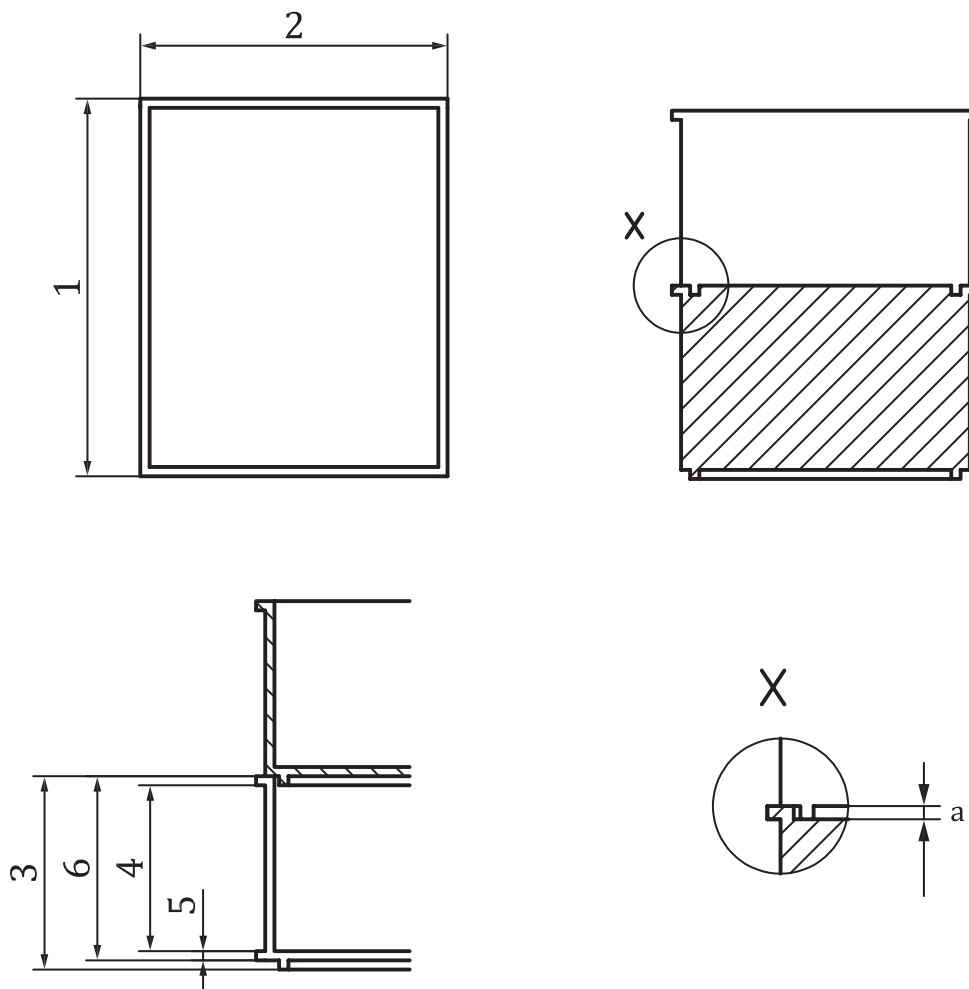

a Height  $\geq$  location height.

**Figure 3 — Rigid parallelepipedic and rectangular box**

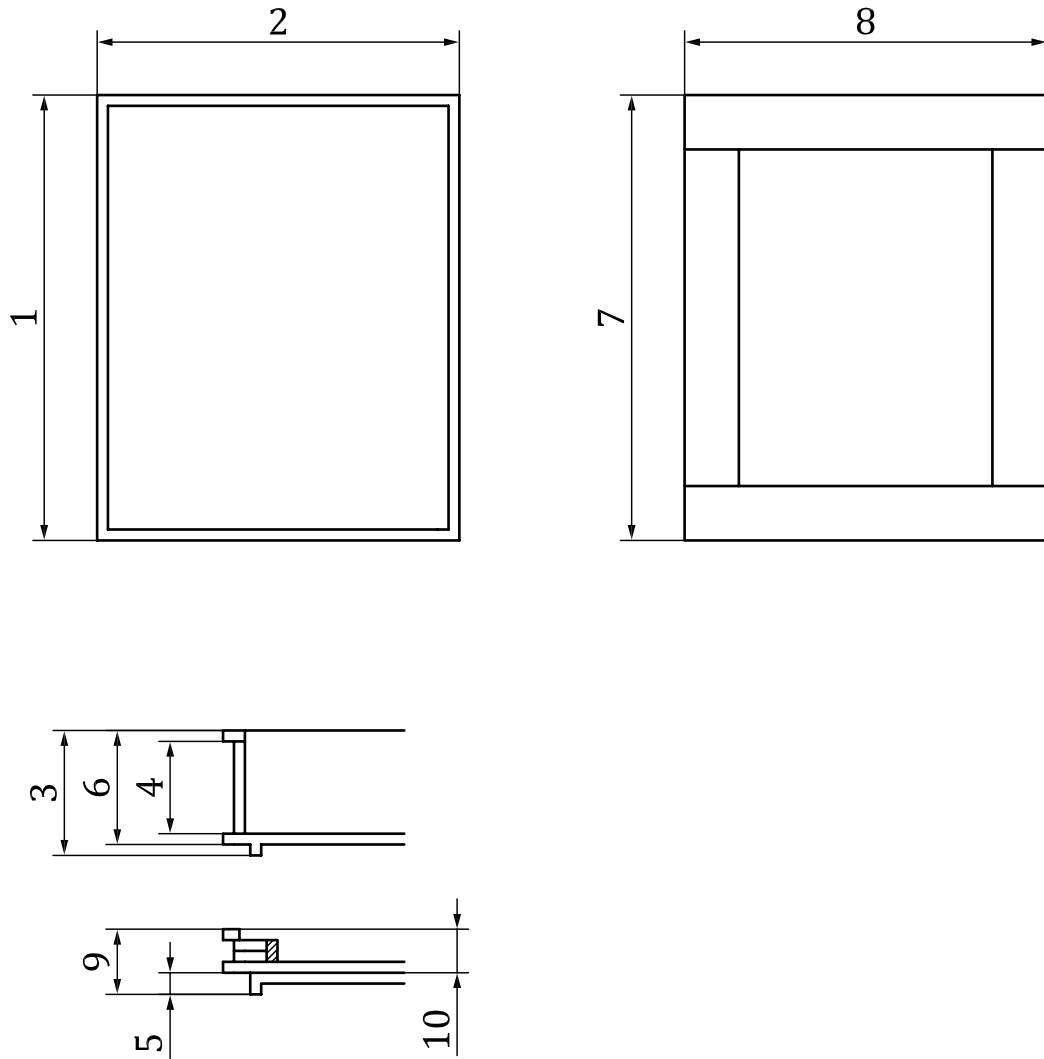

Figure 4 — Foldable box without plan view dimensions changed (1 = 7 and 2 = 8)

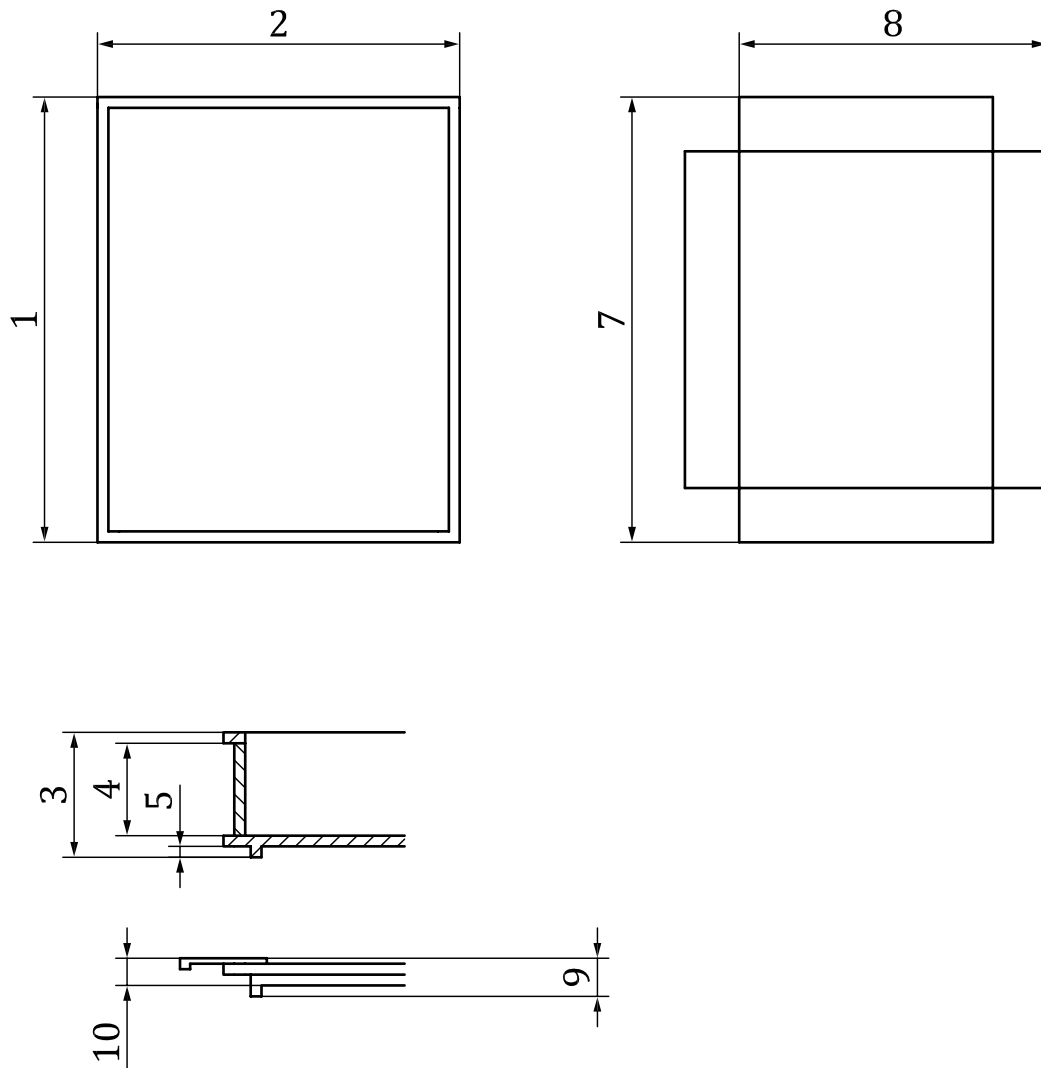
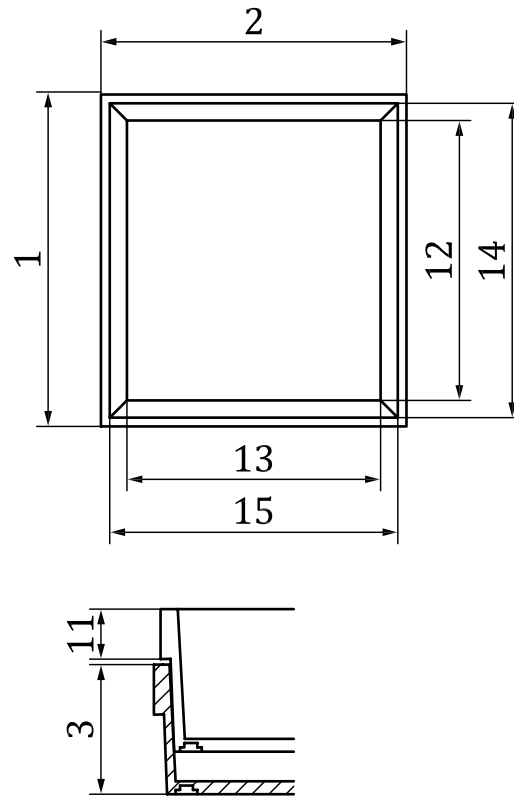

Figure 5 — Foldable box with plan view dimensions changed



**Figure 6 — Nestable box**

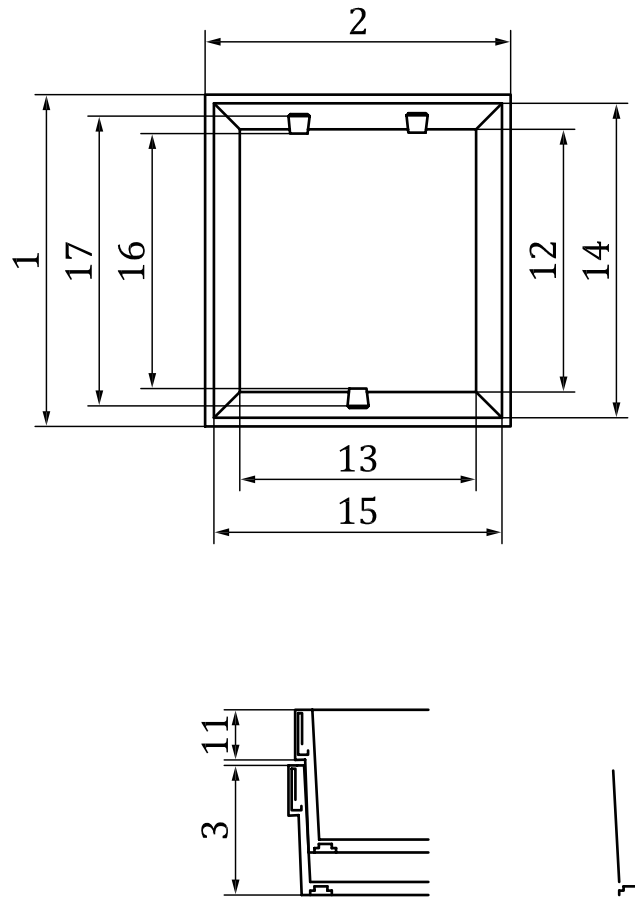

Figure 7 — Nestable and stackable boxes

## 5 Dimensions

### 5.1 Plan view dimensions

All rigid plastic distribution boxes, including foldable boxes in erected position, shall be based on the standard plan dimensions (modules) of 600 mm × 400 mm, 600 mm × 500 mm and 550 mm × 366 mm, as outlined in ISO 3394 and ISO 3676, which define the plan dimensions of four series (1 219 mm × 1 016 mm, 1 200 mm × 1 000 mm, 1 200 mm × 800 mm, and 1 100 mm × 1 100 mm). The plan view dimensions of the boxes shall be subdivisions of the modular area. The plan view dimensions shall not exceed the modular dimensions. There shall be no deviation greater than 0,5 % from the nominal dimensions.

### 5.2 Slippage prevention

The individual boxes shall be stacked in such a manner so as to prevent slippage.

EXAMPLE A flange height of 8 mm has been found to be effective to prevent slippage.

### 5.3 Box tare mass

The deviation shall be not greater than ±3 %.

### 5.4 Nominal stacking load

The nominal stacking load shall be as specified by the manufacturer.



## 6 Safety

### 6.1 Safety in stacking

To prevent any risk of stacked boxes collapsing when operated either in unit loads or single stack columns, they shall conform to the requirements specified in ISO 18616-2. This applies both to static and dynamic situations.

### 6.2 Safety in handling

To avoid injury, the boxes shall be free of flash and burrs.

## 7 Identification

The identification number shall include

- the unique identification of the manufacturer,
- the serial number, and
- the designation of the box.

A unique identifier of a plastic distribution box may be up to 35 alphanumeric characters in length, excluding the Data Identifier (an3+an..35). With the mutual agreement of the trading partners, this length can be extended to 50 characters (an3+an..50). A unique identifier of returnable packaging items (accessories to the plastic distribution box) may be up to 50 alphanumeric characters in length, excluding the Data Identifier (an3+an..50).

### 7.1 Unique identification of the returnable transport box

The unique identification of RTIs shall be in accordance with ISO/IEC 15459-5. Unique identification is provided by three components:

- a) issuing agency code (IAC);
- b) company identification number (CIN);
- c) serial number.

All serial numbers shall be unique within the manufacturers CIN.

### 7.2 Designation of the box

The box designation shall consist of an alphanumeric code and a 7-digit number as shown in subsections (a) and (b) below. Additional data shown in subsections (c) to (f) may be included. Each field (a) and (b) and optionally (c) to (f) shall be separated by a hyphen (-) character. If any of the optional fields shown in subsections (c) to (f) are not included, a placeholder hyphen shall be encoded.

## ISO 18616-1:2016(E)

a) Alphanumeric code for box type:

- 1) S: (Stackable box) Parallelepipedic rigid and rectangular box;
- 2) N: Nestable box;
- 3) SN: Stackable and nestable box;
- 4) F: Foldable box.

EXAMPLE 1 For the designation of a stackable and nestable box: ... SN ...

b) 7-digit numeric code for box size:

- 1) The first digit shall indicate the overall external length (not folded).
- 2) The second digit shall indicate the overall external width (not folded).
- 3) The third and fourth digits shall indicate the overall external height (not folded).

The first two digits of the length and width shall be used, e.g. 5536280.

If height is not divisible evenly by 10, the first two digits of the length and width and the full height shall be used, e.g. 6040275.

EXAMPLE 2 For the designation of a stackable and nestable box of 550 mm overall length, 366 mm wide and 280 mm high: ...SN-5536280...

EXAMPLE 3 For the designation of a stackable and nestable box of 600 mm overall length, 500 mm wide and 280 mm high: ...SN-6050280...

EXAMPLE 4 For the designation of a stackable and nestable box of 600 mm overall length, 400 mm wide and 275 mm high: ...SN-6040275...

c) Date of manufacture, expressed in the form: two-digit month and two-digit year.

EXAMPLE 5 For a box as identified in (b) (EXAMPLE 2) above, manufactured in May 2009, the data string would be SN-5536280-0509.

d) Tare mass, expressed in kilograms (kg) including two decimals.

EXAMPLE 6 For a box as identified in (c) (EXAMPLE 2) above, having a tare mass of 2,6 kg, the data string would be SN-5536280-0509-02.60.

e) Nominal load, expressed in kilograms (kg).

EXAMPLE 7 For a box as identified in (d) (EXAMPLE 2) above, having a nominal load of 30 kg, the data string would be SN-5536280-0509-02.60-30.

f) Nominal stacking load, expressed in kilograms (kg).

EXAMPLE 8 For a box as identified in (e) (EXAMPLE 1) above, having a nominal stacking load of XX kg, the data string would be SN-5536280-0509-02.60-30-XX.

g) Example of structure with one field not included.

EXAMPLE 9 For a box as identified in (f) (EXAMPLE 1) above, without the date of manufacture, the data string would be SN-5536280--02.60-30-XX.

## 8 Marking and labelling

### 8.1 Marking

#### 8.1.1 Symbology requirements

Data may be marked in either or both of the following permanent marking methods:

- in human-readable form;
- in machine-readable form.

ISO/TR 17350 explains the direct marking technologies of laser etch and dot peen. If the identification is directly marked with an intrusive technology, it shall follow the guidance provided in ISO/TR 17350 and ISO/IEC/TR 24720, and it shall comply with the following requirements.

- a) Symbology shall be either QR Code Model 2 (ISO/IEC 18004) or Data Matrix ECC 200 (ISO/IEC 16022), and with symbology identifiers given in ISO/IEC 15424.
- b) Syntax shall be in accordance with ISO/IEC 15434 and semantics shall be in accordance with ISO/IEC 15418.
- c) 2D symbol "X" dimensions shall be 0,4 mm or greater, but not larger than 0,8 mm for direct marking. With express trading partner agreement, the "X" dimension may be as small as 0,15 mm or symbols sizes as small as 10 mm × 10 mm, if the issuing agency has specific rules those shall apply.
- d) Encryption shall not be used.
- e) Quiet zone: The QR Code Model 2 symbol shall have a minimum quiet zone of four (4) times the "X" dimension width on all four sides of the symbol.
- f) Subject to the guidance provided in ISO/TR 17350 and ISO/IEC 18004, the error correction level for QR Code symbols shall be M, Q or H. The error correction level is determined by many factors, including the surface type, operating environment, symbol quality and reading device(s) used.
- g) Symbol quality: A QR Code Model 2 symbol shall conform to ISO/IEC/TR 29158 and have a minimum symbol quality of DPM2.0/10/660/(30Q|90), where "15 to 30" indicates an X-dimension range of 0,4 to 0,8 mm, "660" indicates that the symbol is illuminated with a narrowband light source centred around 660 nm. The "30Q" light source angle shall be 45°. ISO/IEC/TR 24720 is recommended as a guideline for directly marking a Data Matrix symbol on various materials.
- h) Quiet zone: The Data Matrix symbol shall have a minimum quiet zone of one (1) times the "X" dimension width on all four sides of the symbol.
- i) The error correction level for Data Matrix symbols shall be ECC 200 as defined in ISO/IEC 16022.
- j) Symbol quality: A Data Matrix ECC symbol shall conform to ISO/IEC/TR 29158 and have a minimum symbol quality of DPM1.5/08/660/9045, where the minimum overall symbol-grade is 1,5 (C), measured with an aperture size of 0,20 mm with a narrowband light source, at an angle of incidence of 45°. ISO/IEC/TR 24720 is recommended as a guideline for directly marking a Data Matrix symbol on various materials.

#### 8.1.2 Data requirements

The requirement for this document is that data encoded in any machine-readable form shall be as follows.

- a) To identify the returnable transport system box, the unique identification of a returnable transport item (RTI) shall be used with the Data Identifier "25B."

**Table 2 — Unique identification of the RTS box (RTI)**

Data identifier	IAC	CIN	RTI serial number
25B	UN	043325711	N <sub>1</sub> – N <sub>24</sub>

- b) To identify the returnable transport system box accessories, e.g. lids, the unique identification of a reusable transport item (RTI) shall be used with the Data Identifier “55B.”

**Table 3 — Unique identification of the accessory, e.g. lid (RPI)**

Data identifier	IAC	CIN	RPI serial number
55B	UN	043325711	N <sub>1</sub> – N <sub>24</sub>

- c) To identify the box designation, whose data is defined in 7.2, the Data Identifier, e.g. XX, shall precede the box designation.

**Table 4 — Designation of the RTS box**

Data identifier	Alpha code	Numeric code	Date of manufacture (MMYY)	Tare mass (kg)	Nominal load (kg)	Nominal stacking load (kg)
XX	SN	6040975	0509	3,5	30	300

The boxes shall be durably marked in human-readable text with the following data:

- a) unique identification of the item (RTI) [see 7.2 a) and 7.2 b)];
- b) alphanumeric code and 4- to 7-digit numeric code [see 7.2 b)];
- c) month and year of manufacture (MMYY);
- d) tare mass (in kg, expressed up to two decimal places);
- e) nominal load (in kg);
- f) nominal stacking load (in kg).

**EXAMPLE** A stackable-nestable box (SN) prepared in accordance with this document, parallelepipedic, rigid and rectangular, 600 mm long, 400 mm wide and 275 mm high, produced by Reliable Transport Box, during May 2009, tare mass 3,5 kg, nominal load 30 kg and nominal stacking load 300 kg, shall have the following markings displayed:

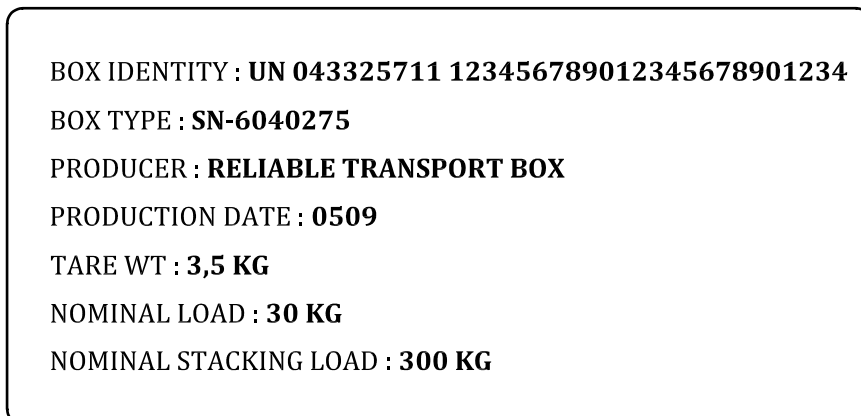

**Figure 8 — Box nameplate**

## 8.2 Labelling

### 8.2.1 General

Boxes shall have areas for both permanent and temporary labelling.

The location of the labels shall be such as to permit automatic fixing and not restrict scanning by barcode reader.

Where required, the labelling area shall have a texture to allow the easy removal of adhesive labels used for temporary identification.

### 8.2.2 Labelling for parallelepipedic type of box

Machine-readable symbols in either QR Code or Data Matrix shall be encoded using an ISO/IEC 15434 Format Indicator "06" syntax, with the unique identification of the RTI encoded first, followed by the box designation.

Where required, to ensure compatibility between the label and a bar code reader, the position of the label shall be as illustrated in [Figure 9](#). The lower edge of the label area shall be positioned on the line  $y$  ( $30 \pm 10$ ) mm from the base on the sides or ends of the box. The minimum distance  $x$  between the vertical label edge and the nearest box rib shall not be less than 10 mm.

For protection against mechanical damage, label areas shall be inset or produced with an embossed border.

NOTE The maximum size of the area available for labelling depends on the position and thickness of the ribs.

## 9 Radio frequency identification (RFID)

When using (attaching) RFIDs, they shall conform to the requirements specified in ISO 17364. The data in [Table 2](#) and [Table 3](#) shall be stored in the UII bank of ISO/IEC 18000-63 type C. The data in [Table 4](#) shall be stored in the USER bank of ISO/IEC 18000-63 type C.

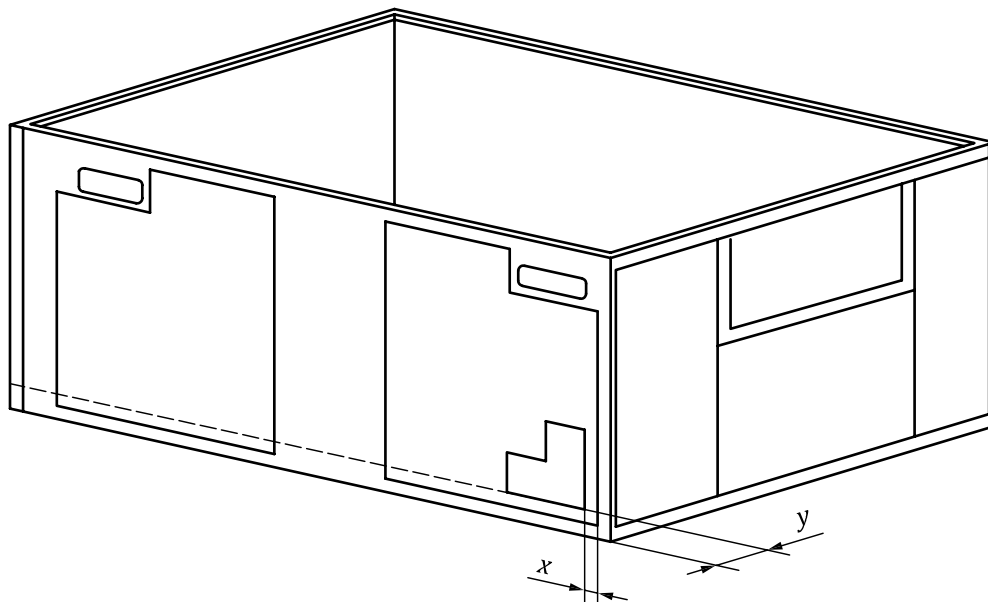

Figure 9 — Example of labelling for parallelepipedic type of box

## Bibliography

- [1] ISO 445:2013, *Pallets for materials handling — Vocabulary*
- [2] ISO 6780:2003, *Flat pallets for intercontinental materials handling — Principal dimensions and tolerances*
- [3] ISO 8785:1998, *Geometrical Product Specification (GPS) — Surface imperfections — Terms, definitions and parameters*
- [4] ISO 11683:1997, *Packaging — Tactile warnings of danger — Requirements*
- [5] ISO/IEC 15418, *Information technology — Automatic identification and data capture techniques — GS1 Application Identifiers and ASC MH10 Data Identifiers and maintenance*
- [6] ISO/IEC 15424, *Information technology — Automatic identification and data capture techniques — Data Carrier Identifiers (including Symbology Identifiers)*
- [7] ISO/TR 17350, *Direct Marking on Plastic Returnable Transport Items (RTIs)*
- [8] ISO/IEC 18004, *Information technology — Automatic identification and data capture techniques — QR Code bar code symbology specification*
- [9] ISO/IEC 19762:2016, *Information technology — Automatic identification and data capture (AIDC) techniques — Harmonized vocabulary*
- [10] ISO 21067:2007, *Packaging — Vocabulary*
- [11] ISO/IEC TR 24720, *Information technology — Automatic identification and data capture techniques — Guidelines for direct part marking (DPM)*
- [12] ISO 28219, *Packaging — Labelling and direct product marking with linear bar code and two-dimensional symbols*
- [13] ISO/IEC/TR 29158, *Information technology — Automatic identification and data capture techniques — Direct Part Mark (DPM) Quality Guideline*



