**Measurement of radioactivity in the
environment — Soil —**

Part 4:

**Measurement of plutonium isotopes
(plutonium 238 and plutonium 239 + 240)
by alpha spectrometry**

Mesurage de la radioactivité dans l'environnement — Sol —

*Partie 4: Mesurage des isotopes du plutonium (plutonium 238 et
plutonium 239 + 240) par spectrométrie alpha*



Reference number
ISO 18589-4:2009(E)

© ISO 2009

PDF disclaimer

This PDF file may contain embedded typefaces. In accordance with Adobe's licensing policy, this file may be printed or viewed but shall not be edited unless the typefaces which are embedded are licensed to and installed on the computer performing the editing. In downloading this file, parties accept therein the responsibility of not infringing Adobe's licensing policy. The ISO Central Secretariat accepts no liability in this area.

Adobe is a trademark of Adobe Systems Incorporated.

Details of the software products used to create this PDF file can be found in the General Info relative to the file; the PDF-creation parameters were optimized for printing. Every care has been taken to ensure that the file is suitable for use by ISO member bodies. In the unlikely event that a problem relating to it is found, please inform the Central Secretariat at the address given below.



COPYRIGHT PROTECTED DOCUMENT

© ISO 2009

All rights reserved. Unless otherwise specified, no part of this publication may be reproduced or utilized in any form or by any means, electronic or mechanical, including photocopying and microfilm, without permission in writing from either ISO at the address below or ISO's member body in the country of the requester.

ISO copyright office
Case postale 56 • CH-1211 Geneva 20
Tel. + 41 22 749 01 11
Fax + 41 22 749 09 47
E-mail copyright@iso.org
Web www.iso.org

Published in Switzerland

Contents

Page

Foreword	iv
Introduction	v
1 Scope	1
2 Normative references	1
3 Terms, definitions and symbols	1
4 Principle	2
5 Chemical reagents and equipment	2
6 Procedure	3
7 Expression of results	4
8 Test report	6
Annex A (informative) Plutonium desorption	7
Annex B (informative) Chemical separation of plutonium by an organic solvent	11
Annex C (informative) Chemical separation of plutonium on anionic resin	13
Annex D (informative) Chemical separation of plutonium by specific resins	15
Annex E (informative) Preparation of the source by electro-deposition	18
Annex F (informative) Preparation of the source by co-precipitation	21
Bibliography	22

Foreword

ISO (the International Organization for Standardization) is a worldwide federation of national standards bodies (ISO member bodies). The work of preparing International Standards is normally carried out through ISO technical committees. Each member body interested in a subject for which a technical committee has been established has the right to be represented on that committee. International organizations, governmental and non-governmental, in liaison with ISO, also take part in the work. ISO collaborates closely with the International Electrotechnical Commission (IEC) on all matters of electrotechnical standardization.

International Standards are drafted in accordance with the rules given in the ISO/IEC Directives, Part 2.

The main task of technical committees is to prepare International Standards. Draft International Standards adopted by the technical committees are circulated to the member bodies for voting. Publication as an International Standard requires approval by at least 75 % of the member bodies casting a vote.

Attention is drawn to the possibility that some of the elements of this document may be the subject of patent rights. ISO shall not be held responsible for identifying any or all such patent rights.

ISO 18589-4 was prepared by Technical Committee ISO/TC 85, *Nuclear energy*, Subcommittee SC 2, *Radiation protection*.

ISO 18589 consists of the following parts, under the general title *Measurement of radioactivity in the environment — Soil*:

- *Part 1: General guidelines and definitions*
- *Part 2: Guidance for the selection of the sampling strategy, sampling and pre-treatment of samples*
- *Part 3: Measurements of gamma-emitting radionuclides*
- *Part 4: Measurement of plutonium isotopes (plutonium 238 and plutonium 239 + 240) by alpha spectrometry*
- *Part 5: Measurement of strontium 90*
- *Part 6: Measurement of gross alpha and gross beta activities*

Introduction

ISO 18589 is published in several parts for use jointly or separately according to needs. Parts 1 to 6 concerning the measurements of radioactivity in the soil have been prepared simultaneously. These parts are complementary and are addressed to those responsible for determining the radioactivity present in soil. The first two parts are general in nature. Parts 3 to 5 deal with nuclide-specific measurements and Part 6 deals with non-specific measurements of gross alpha or gross beta activities.

Additional parts can be added to ISO 18589 in the future if the standardization of the measurement of other radionuclides becomes necessary.

Measurement of radioactivity in the environment — Soil —

Part 4:

Measurement of plutonium isotopes (plutonium 238 and plutonium 239 + 240) by alpha spectrometry

1 Scope

This part of ISO 18589 describes a method for measuring plutonium 238 and 239 + 240 isotopes in soil by alpha spectrometry samples using chemical separation techniques. The method can be used for any type of environmental study or monitoring. These techniques can also be used for measurements of very low levels of activity, one or two orders of magnitude less than the level of natural alpha-emitting radionuclides.

The mass of the test portion required depends on the assumed activity of the sample and the desired detection limit. In practice, it can range from 0,1 g to 100 g of the test sample.

2 Normative references

The following referenced documents are indispensable for the application of this document. For dated references, only the edition cited applies. For undated references, the latest edition of the referenced document (including any amendments) applies.

ISO 31-9, *Quantities and units — Part 9: Atomic and nuclear physics*

ISO 11074, *Soil quality — Vocabulary*

ISO/IEC 17025, *General requirements for the competence of testing and calibration laboratories*

ISO 18589-1, *Measurement of radioactivity in the environment — Soil — Part 1: General guidelines and definitions*

ISO 18589-2, *Measurement of radioactivity in the environment — Soil — Part 2: Guidance for the selection of the sampling strategy, sampling and pre-treatment of samples*

3 Terms, definitions and symbols

For the purposes of this document, the terms, definitions and symbols given in ISO 18589-1, ISO 11074 and ISO 31-9 together with the following symbols apply.

m	Mass of the test portion, expressed in kilograms
a	Activity per unit of mass, expressed in becquerel per kilogram
A	Activity of the tracer added, expressed in becquerel, at the time of measurement
t_g	Sample counting time, expressed in seconds

t_0	Background counting time, expressed in seconds
r_g, r_{gt}	Gross count rate per second from measured plutonium and tracer, respectively
r_0, r_{0t}	Background count rate per second from measured plutonium and tracer, respectively
R	Total measurement yield
$u(a)$	Standard uncertainty associated with the measurement result, expressed in becquerel per kilogram
U	Expanded uncertainty, expressed in becquerel per kilogram, calculated by $U = k \cdot u(a)$ with $k = 1, 2, \dots$
a^*	Decision threshold, expressed in becquerel per kilogram
$a^\#$	Detection limit, expressed in becquerel per kilogram
$a^<, a^>$	Lower and upper limits of the confidence interval, expressed in becquerel per kilogram

4 Principle

The plutonium is deposited as a thin source for measurement by alpha spectrometry using a grid chamber or semi-conductor detector-type apparatus. The sources are usually prepared by electro-deposition or co-precipitation after chemical separation and purification of the plutonium isotopes present in the test portion [1], [2], [3], [4]. Direct deposition on the planchette, such as electro-spraying, can also be used.

Specific chemical separation and purification procedures are required in order to avoid interference from the presence of natural or artificial α -emitters and stable nuclides in the sample, in quantities that are often greater than those of the plutonium isotopes during their measurement.

These procedures allow the removal of the main sources of interference, including

- the salt content of the leaching solutions, especially hydrolyzable elements, in order to prepare the thinnest deposited source,
- other α -emitting radionuclides, such as ^{241}Am and the thorium isotopes, whose emissions can interfere with those of plutonium isotopes.

The total yield for each analysis (chemical separation yield, thin-layer deposit and measurement) is determined by adding a standard solution of ^{236}Pu or ^{242}Pu considered as tracer. As a result, the procedure shall include a valence cycle, adjusting the tracer and the plutonium isotopes being measured to the same oxidation state, in order to achieve identical chemical behaviour for all of them.

5 Chemical reagents and equipment

The chemical reagents and equipment are described in Annex A for plutonium desorption, in Annexes B, C and D for chemical treatment and in Annexes E and F for the preparation of the deposited source.

All the chemical reagents required to carry out this procedure shall be of analytical grade.

6 Procedure

6.1 Plutonium desorption

It is necessary to desorb the plutonium from the soil test portion and into solution. When the plutonium is absorbed onto soil particles from an aqueous solution or onto global fallout particles directly deposited on the soil, it is readily desorbed by direct acid treatment. Plutonium metabolized by animals or plants forms an organic complex that can be found in soil samples. It is released by the destruction of organic matter present in the soil by calcination of the test sample at 500 °C to 600 °C. In some cases, when heated, plutonium can form refractory compounds that require hydrofluoric acid treatment or fusion to make them soluble [4].

Two methods of plutonium desorption are described in Annex A.

In order to quantify the recovery yield, a tracer is added at the start of this step of the procedure; time is allowed, usually up to one day, to obtain equilibrium before starting the plutonium desorption.

6.2 Chemical separation

There are three commonly used techniques for the chemical separation of plutonium: liquid-liquid extraction, extraction on an ion-exchange resin or specific-extraction chromatographic resin. One method from each technique is presented in Annexes B to D: organic solvent [5], separation by anionic resin [6] or by extraction chromatographic resin [7], [8].

6.3 Preparation of the source to be measured

The source can be prepared by deposition, either by electro-deposition on a planchette (a stainless steel disk), or by co-precipitation.

6.3.1 Electro-deposition method

Electro-deposition is carried out after the chemical separation of the plutonium from interfering elements. It allows the electrochemical deposition of the radionuclides in an ultra-thin layer onto the planchette [9], [10]. The procedure described in Annex E applies to the three chemical separation methods described in Annexes B, C and D.

NOTE Electro-deposition is not a selective method because the metal cations likely to form insoluble hydroxides can be deposited at the same time as the plutonium.

6.3.2 Co-precipitation method

Co-precipitation, using fluoride compounds, can be carried out after the chemical separation of the plutonium from other interfering elements. It allows the precipitation of the radionuclide(s) in the form of a thin layer on a filter. The procedure described in Annex F can be applied to the three chemical separation methods described in Annexes B to D.

6.4 Background determination

Measure the background using a blank prepared for the method chosen, starting with a clean test portion (or directly distilled water).

6.5 Measurement

The plutonium activity per unit of mass is calculated by counting the sample source for an appropriate time. The same equipment conditions should be used for the sample, the background and the calibration source measurements.

The counting time required depends on the sample and background count rates and also the detection limit and decision threshold required.

The spectra should be inspected to confirm good peak separation and no interfering peaks.

7 Expression of results

7.1 Calculation of the activity per unit of mass

The plutonium activity is calculated by integrating the number of counts in the corresponding peaks of the radionuclide tracer, ^{238}Pu and/or $^{239} + ^{240}\text{Pu}$, of the alpha emission spectrum of the sample, obtained by alpha spectrometry. The results of these integrations, divided by the counting time, are the gross count rates, r_{gt} and r_{g} , for the tracer and the plutonium isotopes, respectively.

r_{gt} and r_{g} are corrected for the background contribution and, if needed, for the contribution of the tailing of higher-energy peaks, which depends on the detector characteristics.

Background count rates are calculated from the alpha-emission spectrum of a blank sample by integrating the number of counts in the regions of interest (ROI) in which the peaks appear in the sample spectrum. The result of this integration, divided by the counting time, is the background count rate, $r_{0\text{t}}$ and r_0 , for the tracer and the plutonium isotopes, respectively.

NOTE The blank sample is obtained and measured by applying the procedure used in the analysis without soil and with or without tracer.

The activity per unit of mass, a , of the plutonium isotope is calculated as given in Equation (1):

$$a = (r_{\text{g}} - r_0) / (m \cdot R) = (r_{\text{g}} - r_0) \cdot w \quad (1)$$

where $w = \frac{1}{m \cdot R}$.

The total measurement yield, R , is determined from the activity, A , of the tracer added, and the net count rate in the corresponding peak is calculated as given in Equation (2):

$$R = (r_{\text{gt}} - r_{0\text{t}}) / A \quad (2)$$

The detector efficiency allows one to calculate the chemical yield. This value is important for quality control.

7.2 Standard uncertainty

According to ISO/IEC Guide 98-3 [13], the standard uncertainty of a is calculated by Equation (3):

$$\begin{aligned} u(a) &= \sqrt{w^2 \cdot [u^2(r_{\text{g}}) + u^2(r_0)] + a^2 \cdot u_{\text{rel}}^2(w)} \\ &= \sqrt{w^2 \cdot (r_{\text{g}}/t_{\text{g}} + r_0/t_0) + a^2 \cdot u_{\text{rel}}^2(w)} \end{aligned} \quad (3)$$

where the uncertainty of the counting time is neglected.

The relative standard uncertainty of w is calculated by Equation (4):

$$u_{\text{rel}}^2(w) = u_{\text{rel}}^2(R) + u_{\text{rel}}^2(m) \quad (4)$$

The relative standard uncertainty of R is calculated by Equation (5):

$$\begin{aligned} u_{\text{rel}}^2(R) &= u_{\text{rel}}^2(r_{\text{gt}} - r_{\text{0t}}) + u_{\text{rel}}^2(A) \\ &= (r_{\text{gt}}/t_{\text{g}} + r_{\text{0t}}/t_{\text{0}}) / (r_{\text{gt}} - r_{\text{0t}})^2 + u_{\text{rel}}^2(A) \end{aligned} \quad (5)$$

$u_{\text{rel}}(A)$ includes all the uncertainties related to the tracer activity, that is, those of the standard solution, of the preparation of the tracer solution and of the addition of the tracer solution to sample.

The calculation of the characteristic limits (see ISO 11929^[12]) requires a determination of $\tilde{u}(\tilde{a})$, i.e., the standard uncertainty of a as a function of its true value, as calculated by Equation (6):

$$\tilde{u}(\tilde{a}) = \sqrt{w^2 \cdot [(a/w + r_0)/t_g + r_0/t_0] + \tilde{a}^2 \cdot u_{\text{rel}}^2(w)} \quad (6)$$

7.3 Decision threshold

The decision threshold, a^* , is obtained from Equation (6) for $\tilde{a} = 0$ (see ISO 11929). This yields Equation (7):

$$a^* = k_{1-\alpha} \cdot \tilde{u}(0) = k_{1-\alpha} \cdot w \cdot \sqrt{r_0/t_g + r_0/t_0} \quad (7)$$

$\alpha = 0,05$ with $k_{1-\alpha} = 1,65$ is often chosen by default.

7.4 Detection limit

The detection limit, $a^\#$, is calculated by Equation (8) (see ISO 11929):

$$\begin{aligned} a^\# &= a^* + k_{1-\beta} \cdot \tilde{u}(a^\#) \\ &= a^* + k_{1-\beta} \cdot \sqrt{w^2 \cdot [(a^\#/w + r_0)/t_g + r_0/t_0] + a^{\#2} \cdot u_{\text{rel}}^2(w)} \end{aligned} \quad (8)$$

$\beta = 0,05$ with $k_{1-\beta} = 1,65$ is often chosen by default.

The detection limit can be calculated by solving Equation (8) for $a^\#$ or, more simply, by iteration with a starting approximation $a^\# = 2 \cdot a^*$.

By taking $\alpha = \beta$, then $k_{1-\alpha} = k_{1-\beta} = k$ and the solution of Equation (8) is given by Equation (9):

$$a^\# = \frac{2 \cdot a^* + (k^2 \cdot w)/t_g}{1 - k^2 \cdot u_{\text{rel}}^2(w)} \quad (9)$$

7.5 Confidence limits

The lower limit, a^{\triangleleft} , and the upper limit, a^{\triangleright} , of the confidence interval are calculated using Equations (10) and (11) (see ISO 11929):

$$a^{\triangleleft} = a - k_p \cdot u(a); p = \omega \cdot (1 - \gamma/2) \quad (10)$$

$$a^{\triangleright} = a + k_q \cdot u(a); q = 1 - \omega \cdot \gamma/2 \quad (11)$$

where

$\omega = \Phi[y/u(y)]$, where Φ is the distribution function of the standardized normal distribution.

ω may be set equal to 1 if $a \geq 4 \cdot u(a)$ and Equation (12) applies:

$$a^{\triangleleft \triangleright} = a \pm k_{1-\gamma/2} \cdot u(a) \quad (12)$$

$\gamma = 0,05$ with $k_{1-\gamma/2} = 1,96$ is often chosen by default.

8 Test report

The test report shall conform to ISO/IEC 17025 requirements and shall contain the following information:

- a) reference to this part of ISO 18589
- b) identification of the sample;
- c) units in which the results are expressed;
- d) test result, $a \pm u(a)$ or $a \pm U$, with the associated k value.

Complementary information can be provided such as the following:

- probabilities α , β and $(1 - \gamma)$;
- decision threshold and the detection limit;
- depending on the customer request, there are different ways to present the result:
 - when the activity per unit of mass, a , is compared with the decision threshold (see ISO 11929), the result of the measurement should be expressed as $\leq a^*$ when the result is below the decision threshold;
 - when the activity per unit of mass, a , is compared with the detection limit, the result of the measurement can be expressed as $\leq a^\#$ when the result is below the detection limit. If the detection limit exceeds the guideline value, it shall be documented that the method is not suitable for the measurement purpose;
- any relevant information likely to affect the results.

Annex A (informative)

Plutonium desorption

A.1 Principles

The radioactive tracers, ^{236}Pu or ^{242}Pu , are added during this initial treatment phase.

The test portion is ashed between 550 °C and 600 °C and in this situation the extraction of the plutonium might not be possible without a multiple-acid digestion (see A.4.1).

When the test portion of soil does not contain organic matter, plutonium from hot particles or high-fired plutonium, the sample should not be ashed but rather the plutonium extracted by nitric acid digestion (see A.4.2).

A.2 Chemical reagents

A.2.1 Certified solution of ^{236}Pu or ^{242}Pu tracer.

A.2.2 Hydrochloric acid, concentrated, $c(\text{HCl}) = 12,0 \text{ mol/l}$, $\rho = 1,19 \text{ g/ml}$, mass fraction $w(\text{HCl}) = 37 \%$.

A.2.3 Nitric acid, concentrated, $c(\text{HNO}_3) = 14,4 \text{ mol/l}$, $\rho = 1,40 \text{ g/ml}$, mass fraction $w(\text{HNO}_3) = 65 \%$.

A.2.4 Nitric acid, diluted, $c(\text{HNO}_3) = 8 \text{ mol/l}$.

A.2.5 Hydrogen peroxide, $w(\text{H}_2\text{O}_2) = 30 \%$.

A.2.6 Sodium nitrite (NaNO_2).

A.2.7 Hydrofluoric acid, concentrated, $c(\text{HF}) = 22,6 \text{ mol/l}$, $\rho = 1,13 \text{ g/ml}$, mass fraction $w(\text{HF}) = 48 \%$ to 51 %.

A.2.8 Oxalic acid.

A.2.9 Nitric acid, diluted, $c(\text{HNO}_3) = 4 \text{ mol/l}$.

A.2.10 Calcium nitrate.

A.2.11 Ammonium hydroxide (NH_4OH).

A.2.12 Ferric chloride (FeCl_3) **solution.**

A.2.13 Sodium hydroxide (NaOH).

A.2.14 Hydrochloric acid, diluted, $c(\text{HCl}) = 9,0 \text{ mol/l}$.

A.3 Equipment

A.3.1 Standard laboratory equipment.

A.3.2 Analytical balance, accurate to 0,1 mg.

A.3.3 Hot plate.

A.3.4 Centrifuge and tubes.

A.3.5 Furnace.

A.3.6 Crucible.

A.3.7 Beaker, Teflon¹⁾.

A.4 Procedure

A.4.1 Multiple-acid digestion

This procedure, based on a cycle of acid leaching and dry evaporation, includes the following steps.

- a) Weigh between 0,1 g and 15 g of the test sample prepared in accordance with ISO 18589-2. The mass of the test portion shall depend on the expected activity of the sample and the required detection limit.
- b) Ash the test portion at between 550 °C and 600 °C for at least 5 h; leave it to cool in the crucible (A.3.6).
- c) Transfer the sample to a glass beaker and gradually add 10 ml of diluted HNO₃ (A.2.4) per gram of sample and stir.
- d) Wait up to one day.
- e) Add the ²³⁶Pu or ²⁴²Pu tracer solution (A.2.1) and homogenize by stirring.
- f) Add slowly 150 ml of concentrated HNO₃ (A.2.3) and 50 ml of concentrated HCl (A.2.2).
- g) Boil for 1 h while stirring.
- h) Cool to room temperature.
- i) Decant the liquid into another beaker and retain.
- j) Repeat steps e) to h) combining the liquid with the reserved solution and evaporate to dryness.
- k) Transfer the remaining soil to a Teflon beaker (A.3.7) with 30 ml of concentrated HNO₃ (A.2.3), add 15 ml of HF (A.2.7) and evaporate to dryness.
- l) Add 30 ml of concentrated HNO₃ (A.2.3) and 30 ml of HF (A.2.7). Evaporate to dryness.
- m) Add 5 ml of concentrated HNO₃ (A.2.3) and 1 ml H₂O₂ (A.2.5). Evaporate to dryness.
- n) Add 20 ml of concentrated HNO₃ (A.2.3) in 5 ml amounts, drying between each aliquot.

1) TeflonTM is an example of a suitable product available commercially. This information is given for the convenience of users of this part of ISO 18589 and does not constitute an endorsement by ISO of this product.

- o) Transfer the remaining solids to a centrifuge tube (A.3.4) using 8 molar HNO_3 (A.2.4). Centrifuge and mix this solution with the liquid retained from step h).
- p) Repeat step n) twice with 50 ml of 8 molar HNO_3 (A.2.4).
- q) Evaporate the mixed solution to near dryness and dissolve in 50 ml of 8 molar HNO_3 (A.2.4).

The test portion is ready to undergo radiochemical separation.

NOTE It is possible to use larger test portions, but a final step of plutonium precipitation is required to avoid possible interference with stable elements that it is necessary to eliminate before the radiochemical separation. This precipitation consists of the addition of FeCl_3 to the solution after digestion and the precipitation of iron when adding ammonia to pH 10. The supernatant is discarded and the analysis continues with the iron precipitate that contains the plutonium and the other actinides.

The dissolution may also be carried out using a microwave digestion apparatus. Operating conditions for each system should be adjusted to the type of apparatus and the nature of the soil to be digested.

A.4.2 Simple nitric acid digestion

This procedure is based on a cycle of acid leaching and dry evaporation.

- a) Weigh between 0,1 g and 15 g of the test sample prepared in accordance with ISO 18589-2. The mass of the test portion depends on the expected activity of the sample and the required detection limit.
- b) Gradually add 10 ml of 8 molar HNO_3 (A.2.4) per gram of sample.
- c) Add the ^{236}Pu or ^{242}Pu tracer (A.2.1) and homogenize by stirring.
- d) Digest on a hot plate (A.3.3) for at least 8 h with intermittent additions of H_2O_2 (A.2.5). Leave it to cool.
- e) Transfer the test portion to a centrifuge tube (A.3.4) and separate the solid matter from the liquid phase. The supernatant is stored.

NOTE 1 Instead of centrifuging the test portion, it can be filtered using a fibreglass filter.

- f) Rinse the beaker with 8 molar HNO_3 (A.2.4), add to the same tube (A.3.4), stir and centrifuge. Add the supernatant to the liquid retained in step e). Repeat the process until the supernatant is clear.
- g) Evaporate the supernatant to dryness.
- h) Add 50 ml of 8 molar HNO_3 (A.2.4).
- i) Add 0,6 g of NaNO_2 (A.2.6), heat to remove the nitrous fumes and leave it to cool.

The test portion is ready to undergo a radiochemical separation.

NOTE 2 It is possible to use larger test portions, but a final step of plutonium precipitation is required to avoid possible interference with stable elements that it is necessary to eliminate before the radiochemical separation. This precipitation consists of the addition of FeCl_3 to the solution after digestion and the precipitation of iron when adding ammonia to pH 10. The supernatant is discarded and the analysis continues with the iron precipitate that contains the plutonium and the other actinides.

The dissolution may also be carried out using a microwave digestion apparatus. Operating conditions for each system should be adjusted to the type of apparatus used and the nature of the soil to be digested.

A.4.3 Precipitation for plutonium and americium

When americium, in addition to plutonium, is measured on the same large-mass test portion, the specific precipitation procedure shall be adapted as follows.

- a) Once the leaching is completed, add 50 g of oxalic acid (A.2.8) and 200 mg of Ca as nitrate (A.2.10).
- b) Precipitate with NH_4OH (A.2.11) to a pH of 2,5. This allows the co-precipitation of Pu with calcium oxalate and the separation of Fe and other cations as the precipitation is done at a very low pH.
- c) The system is maintained at 90 °C whilst stirring for 6 h and then the crystals are allowed to grow overnight.
- d) The supernatants are transferred to a beaker and the precipitate is preserved.
- e) Add 200 mg of Ca (A.2.10) to the supernatants and repeat the previous steps.
- f) The final precipitate is dissolved with 8 molar HNO_3 (A.2.4) and then is transferred to a 250 ml beaker.
- g) Evaporate on a hot plate (A.3.3) to dryness and eliminate the oxalate completely.
- h) Once the oxalate is eliminated, dissolve in 4 molar HNO_3 (A.2.9) and add 50 mg of Fe in a solution of FeCl_3 (A.2.12). Then precipitate with NaOH (A.2.13) to a pH of 12.
- i) Filtrate and eliminate the supernatants.
- j) Dissolve the precipitate with 9 molar HCl (A.2.14).
- k) Evaporate to dryness.
- l) Add 50 ml of 8 molar HNO_3 (A.2.4).
- m) Add 0,6 g of NaNO_2 (A.2.6), heat to remove the nitrous fumes and leave to cool.

The test portion is ready to undergo a radiochemical separation.

Annex B (informative)

Chemical separation of plutonium by an organic solvent

B.1 Principle

The plutonium isotopes are extracted from the sample solution, in a nitric medium (1 mol/l to 10 mol/l), using a organic cation exchanger (HDEHP) after adjustment to valence IV. The purification of the organic phase is completed by washing the solution in 6 molar HCl. Finally, the plutonium is extracted again in an aqueous medium using a mixture of 6 molar HCl and KI.

B.2 Chemical reagents

B.2.1 HDEHP [di (2 ethylhexyl) hydrogen phosphate] **solution**. 145 ml of HDEHP for 855 ml of heptane.

Ensure the reagent is pure by washing it in an equal volume of water whose pH after this operation shall be greater than 3.

B.2.2 Heptane (C₇H₁₆).

B.2.3 Hydrochloric acid, diluted, $c(\text{HCl}) = 6 \text{ mol/l}$.

B.2.4 Potassium iodide (KI), crystallized.

B.2.5 Nitric acid, diluted, $c(\text{HNO}_3) = 4 \text{ mol/l}$.

B.2.6 Sodium nitrite (NaNO₂), crystallized.

B.3 Equipment

B.3.1 Standard laboratory equipment.

B.3.2 Scales, to an accuracy of 0,1 mg.

B.3.3 Evaporator or hot plate.

B.3.4 Sepatory funnels, adapted to the volumes being treated.

B.3.5 Stirrer, automatic, for the sepatory funnel.

B.4 Procedure

This procedure is carried out after the digestion of the samples described in Annex A with three main steps: extraction, washing the organic phase and re-extraction of plutonium isotopes.

B.4.1 Extraction of plutonium

This procedure includes the following steps.

- a) Take an aliquot or all of the solution being analysed, which shall be clear [if not, dilute the solution with HNO_3 (B.2.5)].
- b) Adjust the plutonium to an oxidation state of IV by adding several milligrams of NaNO_2 (B.2.6).
- c) Leave to react for 10 min.
- d) Transfer this solution into a separatory funnel and balance by stirring vigorously for 15 min in an equal volume of HDEHP diluted to 15 % in heptane (B.2.2).

B.4.2 Washing of the organic phase

This procedure includes the following steps.

- a) Once settled, remove the aqueous phase.
- b) Wash the organic phase in the same volume of HCl (B.2.3) for 5 min.
- c) Leave to settle and throw away the aqueous phase. Repeat this operation until the solution is completely discoloured (to remove the iron).

B.4.3 Re-extraction of plutonium in an aqueous phase

This procedure includes the following steps.

- a) Add 25 ml of 6 molar HCl (B.2.3) and 500 mg of KI (B.2.4) to the organic phase and re-extract the plutonium in an aqueous phase by stirring vigorously for 15 min.
- b) Leave it to settle.
- c) Transfer the aqueous phase into a second separatory funnel (B.3.4).
- d) Wash for 5 min in an equal volume of heptane (B.2.2) to remove traces of HDEHP.
- e) Collect the aqueous phase in a 100 ml beaker.

Annex C (informative)

Chemical separation of plutonium on anionic resin

C.1 Principle

The plutonium isotopes are separated from the other radionuclides and from the soil matrix in an anionic complex form using an ion-exchange resin in a column with media of nitric and hydrochloric acid.

C.2 Chemical reagents

C.2.1 Hydrochloric acid, concentrated, $w(\text{HCl}) = 37\%$.

C.2.2 Nitric acid, concentrated, $w(\text{HNO}_3) = 65\%$.

C.2.3 Ammonia, concentrated, $w(\text{NH}_4\text{OH}) = 25\%$.

C.2.4 Sodium nitrite (NaNO_2).

C.2.5 Anionic resin, 1X8, 100/200 mesh.

C.2.6 Nitric acid, diluted, $c(\text{HNO}_3) = 8\text{ mol/l}$.

C.2.7 Hydrochloric acid, diluted, $c(\text{HCl}) = 8\text{ mol/l}$.

C.2.8 Hydroxyl ammonium chloride $c(\text{NH}_3\text{OH})\text{Cl} = 0,2\text{ mol/l}$ in hydrochloric acid, $c(\text{HCl}) = 2\text{ mol/l}$.

C.3 Equipment

C.3.1 Standard laboratory equipment.

C.3.2 Hot plate.

C.3.3 Column, glass, 30 ml.

C.4 Procedure

This procedure is carried out, after the digestion of the sample as described in Annex A, and includes two main steps: chemical separation and elution.

C.4.1 Separation of plutonium

- a) Fill the column with the resin (C.2.5).
- b) Prepare the 8 molar nitric solution (C.2.6).

- c) Convert the resin to the nitrate form by passing 150 ml of the 8 molar HNO_3 (C.2.6) at a flow rate of approximately 1 ml/min.
- d) Pour the Pu solution into the top of the column.
- e) Wash the column and beaker with portions of 8 molar HNO_3 (C.2.6), up to 150 ml at a flow rate of approximately 1 ml/min. Discard the washings.
- f) Wash the column with 80 ml of 8 molar HCl (C.2.7). Discard the washings.

C.4.2 Elution of plutonium

- a) Place a clean beaker under the column.
- b) Elute the Pu with 90 ml of 0,2 molar $(\text{NH}_3\text{OH})\text{Cl}$ in 2 mol/l HCl (C.2.8) at a flow rate of approximately 0,5 ml/min.
- c) Evaporate the eluate slowly until the volume is less than 25 ml and add carefully 2 ml of concentrated HNO_3 (C.2.2).
- d) When the presence of relatively important amounts of other actinides is suspected, it is necessary to carry out a purification process that basically consists of the repetition of the following steps:
 - 1) Evaporate the eluate to dryness.
 - 2) Add 50 ml of 8 molar HNO_3 (C.2.6).
 - 3) Add 0,6 g of NaNO_2 (C.2.4) and heat to remove the nitrous fumes and leave to cool.
 - 4) Repeat the procedure from C.4.1 to separate and elute the Pu.

Annex D (informative)

Chemical separation of plutonium by specific resins

D.1 Principle

This technique is based on the selective chromatographic extraction of Pu using a resin containing a specific extractant CMPO/TBP (for example TRU-Spec[®] 2). The chemical separation is fast and well suited for monitoring plutonium activity in the environment.

D.2 Chemical reagents

D.2.1 Nitric acid (HNO₃), 3 mol/l containing aluminium nitrate, $c[\text{Al}(\text{NO}_3)_3] = 0,5 \text{ mol/l}$.

D.2.2 Nitric acid, $c(\text{HNO}_3) = 2 \text{ mol/l}$, containing 0,1 mol/l sodium nitrite, $c(\text{NaNO}_2) = 0,1 \text{ mol/l}$.

D.2.3 Nitric acid, concentrated, at least $w(\text{HNO}_3) = 69 \%$.

D.2.4 Nitric acid (HNO₃), diluted, different concentrations:

D.2.4.1 $c(\text{HNO}_3) = 3 \text{ mol/l}$.

D.2.4.2 $c(\text{HNO}_3) = 2 \text{ mol/l}$.

D.2.4.3 $c(\text{HNO}_3) = 1 \text{ mol/l}$.

D.2.4.4 $c(\text{HNO}_3) = 0,5 \text{ mol/l}$.

D.2.5 Ammonium thiocyanate, diluted, $c(\text{NH}_4\text{SCN}) = 0,1 \text{ mol/l}$.

D.2.6 Ascorbic acid.

D.2.7 Iron sulfamate, 0,6 = mol/l.

D.2.8 Hydrogen peroxide, $w(\text{H}_2\text{O}_2) = 30 \%$.

D.2.9 Hydrochloric acid, concentrated, $w(\text{HCl}) = 37 \%$.

D.2.10 Ammonium oxalate, diluted, $c(\text{NH}_4\text{HC}_2\text{O}_4) = 0,1 \text{ mol/l}$.

D.3 Equipment

D.3.1 Standard laboratory equipment.

D.3.2 Balance, accurate to 0,1 mg.

2) TRU-Spec[®] is an example of a suitable product available commercially. This information is given for the convenience of users of this part of ISO 18589 and does not constitute an endorsement by ISO of this product.

D.3.3 Evaporator or hot plate.

D.3.4 Sepatory funnels, adapted to the volumes to be treated.

D.3.5 Stirring apparatus, for the sepatory funnel.

D.3.6 Resin columns, containing the extractant CMPO/TBP (TRU-Spec®).

D.4 Procedure

This procedure is carried out after the digestion of the samples as described in Annex A and includes two main steps: extraction and elution of plutonium.

D.4.1 Extraction of plutonium

The procedure includes the following steps.

- a) Evaporate the solution being analysed to dryness.
- b) Add 10 ml of 3 mol/l HNO_3 in 0,5 mol/l $\text{Al}(\text{NO}_3)_3$ (D.2.1). Dissolve the precipitate.
- c) Add some drops of NH_4SCN (D.2.5). If the dissolution becomes red, add ascorbic acid (D.2.6) until the colour disappears; then heat and leave to cool.
- d) Repeat step c) if the dissolution is not complete.
- e) Add 1 ml of 0,6 molar iron sulfamate (D.2.7); stir until dissolution.
- f) Add 0,1 g of ascorbic acid (D.2.6), heat until total dissolution and leave to cool.
- g) Set up the CMPO/TBP (TRU-Spec®) column (D.3.6).
- h) Prepare the resin by passing through it 25 ml of 3 molar HNO_3 containing 0,5 mol/l $\text{Al}(\text{NO}_3)_3$ (D.2.1) at a flow rate of approximately 1 ml/min.
- i) Pour the Pu solution onto the top of the column (D.3.6).
- j) Wash the beaker with 5 ml of 3 molar HNO_3 (D.2.4.1) and pour onto the top of the column.
- k) Wash the column with 5 ml of 2 molar HNO_3 (D.2.4.2), 5 ml of 2 molar HNO_3 containing 0,1 molar NaNO_2 (D.2.2) and 5 ml of 0,5 molar HNO_3 (D.2.4.4). Discard the washings.

D.4.2 Elution of plutonium

The procedure includes the following steps.

- a) Place a clean beaker under the column.
- b) Elute the plutonium with 20 ml of 0,1 molar $\text{NH}_4\text{HC}_2\text{O}_4$ (D.2.10).
- c) Evaporate the eluate to dryness. The white precipitate is the oxalate.

D.4.3 Oxalate decomposition

The procedure includes the following steps.

- a) Add 1 ml of 69 % HNO_3 (D.2.3) and five drops of 30 % H_2O_2 (D.2.8), leave to dryness.
- b) Add 1 ml of 69 % HNO_3 (D.2.3), and 1 ml of 37 % HCl (D.2.9), leave to dryness.
- c) Add 1 ml of 69 % HNO_3 (D.2.3), leave to dryness.
- d) Repeat step c) until the precipitate disappears.
- e) Dissolve in 4 ml of 1 molar HNO_3 (D.2.4.3).

Annex E (informative)

Preparation of the source by electro-deposition

E.1 Principle

Applying different voltages between two electrodes using a DC generator leads to the reduction of the metal cations dissolved in the electrolyte. The reduction that takes place at the cathode leads to the formation of a deposit of actinide hydroxides.

E.2 Chemical reagents

- E.2.1 Nitric acid, concentrated, $w(\text{HNO}_3) = 65 \%$.
- E.2.2 Sodium sulfate, $c(\text{Na}_2\text{SO}_4) = 0,3 \text{ mol/l}$.
- E.2.3 Sulfuric acid, concentrated, $w(\text{H}_2\text{SO}_4) = 95 \%$ to 97% .
- E.2.4 Thymol blue, $0,04 \%$.
- E.2.5 Ammonia, concentrated, $w(\text{NH}_4\text{OH}) = 25 \%$.
- E.2.6 Sulfuric acid, diluted, $w(\text{H}_2\text{SO}_4) = 1 \%$.
- E.2.7 Ammonium hydroxide, diluted, $w(\text{NH}_4\text{OH}) = 1 \%$.

E.3 Equipment

E.3.1 Electro-deposition apparatus, composed of

- a) a glass or polyethylene electro-deposition cell;
- b) a platinum wire (anode);
- c) a planchette or stainless steel disc (cathode) with a diameter adapted to the electro-deposition cell;
- d) a DC generator;
- e) a hot plate;
- f) a Petri dish.

E.4 Procedure

E.4.1 Assembly of the electro-deposition cell

This procedure refers to the electro-deposition apparatus designed for deposits on small-diameter stainless steel discs (see Figure E.1). The electro-deposition procedure for this type of apparatus is as follows.

- a) Place the clean and degreased stainless steel disc [E.3.1 c)] in the cap assembly.
- b) Screw on the cell [E.3.1 a)] with the cap assembly.
- c) Fill the cell with water to check for leaks.
- d) Empty the cell.
- e) Fix the platinum wire [E.3.1 b)] vertically to its support.
- f) Attach the lower end of the wire to the side contact of the disk support; the distance between the wire and the disk is approximately 3 mm.

E.4.2 Preparing the deposit

Using the preparation obtained from the purification phase (C.4.2), from the re-extraction of plutonium phase (B.4.3) or from the oxalate decomposition phase (D.4.3), carry out the following operations.

- a) Evaporate to near dryness; care should be taken to avoid evaporating the sample to complete dryness.
- b) Add 1 ml of concentrated HNO_3 (E.2.1) and evaporate to near dryness. Repeat this step three times.
- c) Add 1 ml of 0,3 molar Na_2SO_4 (E.2.2) and evaporate to dryness.
- d) Add 500 μl of 95 % to 97 % H_2SO_4 (E.2.3).
- e) Add 10 ml of distilled water and 3 drops of 0,04 % thymol blue (E.2.4) and stir.
- f) Adjust the pH to between 2,1 and 2,3 by adding concentrated ammonia (E.2.5) (colour changes from red to orange).
- g) Introduce this solution in the electro-deposition cell [E.3.1 a)].
- h) Rinse the beaker with 1 % H_2SO_4 (E.2.6) whose pH was previously adjusted to 2,3 and add it to the electro-deposition cell.
- i) Set up the anode and carry out the electro-deposition at a constant current (about 1,0 A) for approximately 1 h.
- j) One minute before switching off the generator, add 1 ml of 25 % NH_4OH (E.2.5).
- k) Wait 1 min, remove the anode before switching off the generator and quickly empty the cell.
- l) Dismantle the apparatus, rinse the disc with water, then with 1 % NH_4OH (E.2.7), and dry it in hot air or on a hot plate [E.3.1 e)].
- m) Identify the disk and place it in a plastic Petri dish [E.3.1 f)].

The source is ready to be measured by alpha spectrometry.

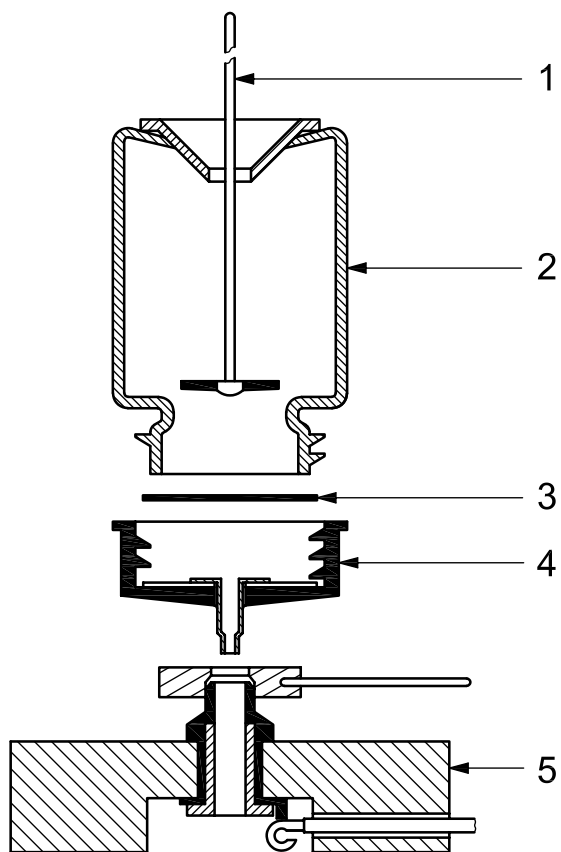

Key

- 1 anode
- 2 scintillation vial
- 3 planchette
- 4 cap assembly
- 5 base

Figure E.1 — Diagram of an electro-deposition cell

Annex F (informative)

Preparation of the source by co-precipitation

F.1 Principle

The plutonium isotopes are recovered by precipitation using lanthanide fluoride.

F.2 Chemical reagents

F.2.1 Hydrochloric acid, $c(\text{HCl}) = 0,2 \text{ mol/l}$.

F.2.2 Ammonia, concentrated, $c(\text{NH}_4\text{OH}) = 25 \%$.

F.2.3 Lanthanum oxide: 99,999 %.

F.2.4 Solution A: 29 mg of lanthanum oxide (F.2.3) dissolved in 100 ml of 0,2 molar HCl (F.2.1).

F.3 Equipment

The equipment used for the co-precipitation method generally includes the following.

F.3.1 Membrane filter, cellulose ester (pore diameter: 0,22 μm).

F.3.2 Planchette or **stainless steel disc**, having a diameter adapted to the spectrometry apparatus.

F.3.3 Filtration system.

F.4 Procedure

Using the preparation obtained from the purification phase (see C.4.2) or from the re-extraction of plutonium phase (see B.4.3) or from the oxalate decomposition step (see D.4.3), carry out the following operations.

- a) Adjust the pH to 1,9 by adding NH_4OH (F.2.2).
- b) Add, for a deposit of 20 cm^2 , the equivalent of 250 μg of lanthanum (i.e. 1 ml of solution A, F.2.4).
- c) Stir, then leave to settle for 10 min.
- d) Recover the precipitate by light vacuum filtering on the membrane filter without forgetting to collect, by rinsing with water, the deposit remaining on the side of the beaker.
- e) Leave the precipitate to dry in open air, then attach the membrane (F.3.1) to the planchette or stainless steel disc (F.3.2).

The source is ready to be measured by alpha spectrometry.

Bibliography

- [1] AIEA³⁾ Technical Report No. 295, *Measurements of radionuclides in food and the environment*, 1989
- [2] LOVETT, M.B., BOGGIS, S.J., BLOWERS, P., The determination of alpha-emitting nuclides of plutonium, americium and curium in environmental materials: Part 1. Sea water Aquatic environment protection: *Analytical methods*, No. 7, MAFF, Directorate of Fisheries Research, Lowestoft (G.B.), 1991
- [3] NUREG-1576, EPA 402-B-04-001A, NTIS PB2004-105421, *Multi-Agency Radiological Laboratory Analytical Protocols Manual (MARLAP)*, 2005
- [4] CLEVELAND, J.M., *The Chemistry of Plutonium*, American Nuclear Society, 1979
- [5] NF M 60-790-8, *Énergie nucléaire — Mesure de la radioactivité dans l'environnement — Sol. Partie 8: Méthodes de mesure des isotopes du plutonium (plutonium 238 and plutonium 239+240) dans les échantillons de sol*, 1999
- [6] U.S. Department of Energy, *The Procedures Manual of the Environmental Measurements Laboratory*, HASL-300, 1999
- [7] HORWITZ, E.P., *New Chromatographic Materials for Determinations of Actinides, Strontium, and Technetium in Environmental, Bioassay, and Nuclear Waste Samples*, 1993
- [8] HORWITZ, E.P., *et al.*, Separation and Preconcentration of Actinides from Acidic Media by Extraction Chromatography, *Analytica Chimica Acta*, Vol. **281**, pp. 361-372, 1993
- [9] HALLSTADIUS, L., A Method for the Electrodeposition of Actinides, *Nuclear Instruments and Methods in Physic Research*, **223**, 1984
- [10] TALVITIE, N.A., Electrodeposition of Actinides for Alpha Spectrometric Determination, *Analytical Chemistry*, Vol. **44**, No. 2, 1972
- [11] WEISE, K., HÜBEL, K., MICHEL, R., ROSE, E., SCHLÄGER, M., SCHRAMMEL, D., TÄSCHNER, M., *Determination of the detection limit and decision threshold for ionizing radiation measurements — Fundamentals and particular applications*; Proposal for a standard, Report FS-05-129-AKSIGMA, Fachverband für Strahlenschutz, TÜV-Verlag (Cologne), 2005
- [12] ISO 11929, *Determination of the characteristic limits (decision threshold, detection limit and limits of the confidence interval) for measurements of ionizing radiation — Fundamentals and application*
- [13] ISO/IEC Guide 98-3, *Uncertainty of measurement — Part 3: Guide to the expression of uncertainty in measurement (GUM:1995)*

3) International Atomic Energy Agency, Vienna, Austria.

.....

ICS 13.080.01; 17.240

Price based on 22 pages