**Non-destructive testing —
Characterization and verification of
ultrasonic phased array equipment —
Part 3:
Combined systems**

*Essais non destructifs — Caractérisation et vérification de
l'appareillage ultrasonore multi-éléments —*

Partie 3: Système complet





COPYRIGHT PROTECTED DOCUMENT

© ISO 2015, Published in Switzerland

All rights reserved. Unless otherwise specified, no part of this publication may be reproduced or utilized otherwise in any form or by any means, electronic or mechanical, including photocopying, or posting on the internet or an intranet, without prior written permission. Permission can be requested from either ISO at the address below or ISO's member body in the country of the requester.

ISO copyright office
Ch. de Blandonnet 8 • CP 401
CH-1214 Vernier, Geneva, Switzerland
Tel. +41 22 749 01 11
Fax +41 22 749 09 47
copyright@iso.org
www.iso.org

Contents

| | Page |
|--|-----------|
| Foreword | v |
| 1 Scope | 1 |
| 2 Normative references | 1 |
| 3 Terms and definitions | 2 |
| 4 Symbols | 2 |
| 5 General requirements for conformity | 3 |
| 6 Modes of operation | 4 |
| 7 Equipment required for tests | 8 |
| 8 Group 1 tests | 9 |
| 8.1 General | 9 |
| 8.2 Elements and channels | 9 |
| 8.2.1 General | 9 |
| 8.2.2 Channel assignment | 9 |
| 8.2.3 Relative sensitivity of elements | 10 |
| 8.3 Beam characterization | 12 |
| 8.3.1 General | 12 |
| 8.3.2 Absence of saturation | 13 |
| 8.3.3 Beam characterization for contact probes | 14 |
| 8.3.4 Beam characterization for immersion probes | 21 |
| 8.4 Imaging check | 24 |
| 8.4.1 General | 24 |
| 8.4.2 Reflector positioning | 25 |
| 8.4.3 -6 dB spot size | 25 |
| 8.4.4 Amplitude comparison | 25 |
| 9 Group 2 tests | 25 |
| 9.1 General | 25 |
| 9.2 Visual inspection of equipment | 26 |
| 9.2.1 Operating procedure | 26 |
| 9.2.2 Acceptance criteria | 26 |
| 9.3 Relative sensitivity of elements | 26 |
| 9.3.1 General | 26 |
| 9.3.2 Operating procedure | 26 |
| 9.3.3 Identification of dead elements | 27 |
| 9.3.4 Compensation of sensitivity variation | 27 |
| 9.3.5 Acceptance criteria | 27 |
| 9.4 Linearity of amplification system | 27 |
| 9.4.1 Operating procedure | 27 |
| 9.4.2 Acceptance criteria | 27 |
| 9.5 Absolute sensitivity of virtual probes | 28 |
| 9.5.1 General | 28 |
| 9.5.2 Operating procedure | 28 |
| 9.5.3 Acceptance criterion | 28 |
| 9.6 Relative sensitivity of virtual probes | 28 |
| 9.6.1 General | 28 |
| 9.6.2 Operating procedure | 28 |
| 9.6.3 Acceptance criterion | 29 |
| 9.7 Probe index points | 29 |
| 9.7.1 General | 29 |
| 9.7.2 Operating procedure | 29 |
| 9.7.3 Acceptance criteria | 29 |
| 9.8 Angle(s) of refraction | 29 |

| | | |
|---|--------------------------------------|-----------|
| 9.8.1 | General..... | 29 |
| 9.8.2 | Operating procedure..... | 30 |
| 9.8.3 | Acceptance criterion..... | 30 |
| 9.9 | Squint angle for contact probes..... | 30 |
| 9.9.1 | General..... | 30 |
| 9.9.2 | Operating procedure..... | 30 |
| 9.9.3 | Reporting..... | 30 |
| 10 | System record sheet..... | 30 |
| Annex A (informative) Tests to be performed and their acceptance criteria..... | | 32 |
| Bibliography..... | | 34 |

Foreword

ISO (the International Organization for Standardization) is a worldwide federation of national standards bodies (ISO member bodies). The work of preparing International Standards is normally carried out through ISO technical committees. Each member body interested in a subject for which a technical committee has been established has the right to be represented on that committee. International organizations, governmental and non-governmental, in liaison with ISO, also take part in the work. ISO collaborates closely with the International Electrotechnical Commission (IEC) on all matters of electrotechnical standardization.

The procedures used to develop this document and those intended for its further maintenance are described in the ISO/IEC Directives, Part 1. In particular the different approval criteria needed for the different types of ISO documents should be noted. This document was drafted in accordance with the editorial rules of the ISO/IEC Directives, Part 2 (see www.iso.org/directives).

Attention is drawn to the possibility that some of the elements of this document may be the subject of patent rights. ISO shall not be held responsible for identifying any or all such patent rights. Details of any patent rights identified during the development of the document will be in the Introduction and/or on the ISO list of patent declarations received (see www.iso.org/patents).

Any trade name used in this document is information given for the convenience of users and does not constitute an endorsement.

For an explanation on the meaning of ISO specific terms and expressions related to conformity assessment, as well as information about ISO's adherence to the WTO principles in the Technical Barriers to Trade (TBT) see the following URL: [Foreword - Supplementary information](#)

This document was prepared by the European Committee for Standardization (CEN) Technical Committee CEN/TC 138, *Non-destructive testing*, in collaboration with ISO Technical Committee ISO/TC 135, *Non-destructive testing*, Subcommittee SC 3, *Ultrasonic Testing*, in accordance with the Agreement on technical cooperation between ISO and CEN (Vienna Agreement).

ISO 18563 consists of the following parts, under the general title *Non-destructive testing — Characterization and verification of ultrasonic phased array systems*:

- *Part 1: Instruments*
- *Part 3: Combined systems*

Non-destructive testing — Characterization and verification of ultrasonic phased array equipment —

Part 3: Combined systems

1 Scope

This part of ISO 18563 addresses ultrasonic test systems implementing linear phased array probes, in contact (with or without wedge) or in immersion, with centre frequencies in the range of 0,5 MHz–10 MHz.

It provides methods and acceptance criteria for verifying the performance of combined equipment (i.e. instrument, probe and cables connected). The methods described are suitable for users working under on-site or shop floor conditions. Its purpose is for the verification of the correct operation of the system prior to testing, and also the characterization of sound beams or verification of the absence of degradation of the system.

The methods are not intended to prove the suitability of the system for particular applications, but are intended to prove the capability of the combined equipment to generate ultrasonic beams according to the settings used.

The calibration of the system for a specific application is outside of the scope of part of ISO 18563 and it is intended that it be covered by the test procedure.

This part of ISO 18563 does not address the following:

- encircling arrays;
- series of apertures having a different number of elements;
- different settings for transmitting and receiving (e.g. active aperture, number of active elements, delays);
- techniques using post-processing of the signals of individual elements in a more complex manner than a simple delay law (e.g. full matrix capture).

2 Normative references

The following documents, in whole or in part, are normatively referenced in this document and are indispensable for its application. For dated references, only the edition cited applies. For undated references, the latest edition of the referenced document (including any amendments) applies.

ISO 5577, *Non-destructive testing — Ultrasonic inspection — Vocabulary*

ISO 18563-1, *Non-destructive testing — Characterization and verification of ultrasonic phased array equipment — Part 1: Instruments*

EN 1330-4, *Non-destructive testing — Terminology — Part 4: Terms used in ultrasonic testing*

EN 16018, *Non-destructive testing — Terminology — Terms used in ultrasonic testing with phased arrays*

EN 16392-2, *Non-destructive testing — Characterization and verification of ultrasonic phased array test equipment — Part 2: Probes*

3 Terms and definitions

For the purposes of this document, the terms and definitions given in ISO 5577, EN 1330-4, EN 16018 and the following apply.

3.1 combined equipment

connected set including the instrument, the probe and connecting cables including adapters

3.2 system

combined equipment including the settings for a given mode of operation

Note 1 to entry: Settings are specific values or ranges of values.

3.3 reference system

system including an instrument according to ISO 18563-1 and a probe according to EN 16392-2, on which all of the Group 1 tests defined in [Clause 8](#) and all Group 2 tests defined in [Clause 9](#) of this part of ISO 18563-3 have been performed successfully

3.4 identical system

system in which instruments, probes and connecting cables are each from the same manufacturer and of the same product name, and the mode of operation and the settings are the same

3.5 mode of operation

specification of shots and active apertures for each position of the probe as reported in [Clause 6](#)

3.6 natural refracted beam

beam in the direction of the natural refracted beam angle

3.7 system record sheet

document for reporting the test results for a system and for comparing with the values obtained from the reference system

4 Symbols

For the purposes of this document, the symbols given in [Table 1](#) apply.

Table 1 — Symbols

| Symbol | Unit | Definitions |
|-----------------|------------|---|
| λ | mm | Wavelength |
| ΔS_{el} | dB | Relative sensitivity of an element |
| a_i | mm | <i>Contact probe</i> : distance between the orthogonal projection of the axis of the hole and the front surface of the probe, see Figure 4 <i>Immersion probe</i> : distance between the orthogonal projection of the axis of the hole and the centre of the probe surface |
| A_{el} | V or %-FSH | Amplitude of one elementary signal |
| A_{mean} | V or %-FSH | Mean value of the amplitudes of all elementary signals |
| A_{ref} | V or %-FSH | Mean value of the amplitudes of all elementary signals, excluding the dead elements, |

Table 1 (continued)

| | | |
|------------------|----|--|
| D | mm | Diagonal of the active aperture |
| d_i | mm | Depth of the holes |
| G_0 | dB | Calibrated gain |
| G_{ref} | dB | Reference gain for the amplitude – distance measurements |
| N | mm | Near field length associated with the active aperture |
| θ | ° | Angle of refraction |
| p | mm | Pitch |
| X | mm | Distance between the probe front surface and the probe index point |

5 General requirements for conformity

The tests to be performed prior to the first use of the system for a given application (mode of operation and settings) are described in [Clause 8](#) (Group 1 tests) and in [Clause 9](#) (Group 2 tests), except the tests described in [9.3](#), [9.8](#) and [9.9](#) which are already performed for Group 1.

When all tests are successful, the system is considered to conform to this part of ISO 18563 and becomes a reference system. If no component and/or setting of the system is modified or replaced, it remains a reference system. Using the system with other settings does not void the reference system, if the original settings can be restored. The results of the tests shall be reported on the system record sheet.

On a system identical to a reference system, only the Group 2 tests have to be performed. When all tests are successful, the system is considered to conform to this part of ISO 18563. During the first performance of the tests, the system record sheet is initialized with the values obtained on the reference system and is completed with the values obtained after the tests.

The Group 2 tests have then to be performed periodically, on any system, on workshop or on site. After each performance of the Group 2 tests, the system record sheet shall be updated.

[Table 2](#) presents the different tests to be performed on a system, featuring an immersion or contact probe.

A summary of all tests to be carried out, including their acceptance criteria, is given in [Table A.1](#).

Table 2 — Tests to be performed

| | Contact probe | Immersion probe |
|--|-------------------------|-------------------------|
| Group 1 tests | | |
| Elements and channels | | |
| Channel assignment | 8.2.2 | 8.2.2 |
| Relative sensitivity of elements | 8.2.3 | 8.2.3 |
| Beam characterization | | |
| Absence of saturation | 8.3.2 | 8.3.2 |
| Angle of refraction — Probe index point | 8.3.3.2 | |
| Angle of refraction — Point of incidence on the test object | | 8.3.4.2 |
| Sensitivity along the beam axis | 8.3.3.3 | 8.3.4.3 |
| Beam dimensions | 8.3.3.4 | 8.3.4.4 |
| Squint angle | 8.3.3.5 | |
| Grating lobes (recommended) | 8.3.3.6 | |
| ^a For the reference system, the test need not to be repeated because it was performed in Group 1. | | |

Table 2 (continued)

| | Contact probe | Immersion probe |
|--|-----------------------|-----------------------|
| Imaging check | | |
| Reflector positioning | 8.4.2 | 8.4.2 |
| −6 dB spot size | 8.4.3 | 8.4.3 |
| Amplitude comparison | 8.4.4 | 8.4.4 |
| Group 2 tests | | |
| Visual inspection of the equipment | 9.2 | 9.2 |
| Relative sensitivity of elements ^a | 9.3 | 9.3 |
| Linearity of the amplification system | 9.4 | 9.4 |
| Absolute sensitivity of virtual probes | 9.5 | 9.5 |
| Relative sensitivity of virtual probes | 9.6 | 9.6 |
| Probe index points ^a | 9.7 | |
| Angle(s) of refraction ^a | 9.8 | 9.8 |
| Squint angle ^a | 9.9 | |
| ^a For the reference system, the test need not to be repeated because it was performed in Group 1. | | |

6 Modes of operation

During ultrasonic testing with phased arrays, a set of beams is generally produced from each position of the probe.

Each beam corresponds to one shot, each being defined by the active aperture and by the delay laws applied. The modes of operation are characterized by the number of apertures (one or multiple) and the number of shots per aperture (one or multiple).

The tests described only address applications in which the transmitting elements are also receiving.

In the scope of this standard, only one received signal is considered for each shot.

Depending on the application the following variants of phased array technique (modes of operation) can be used/combined:

- number of active apertures (one or multiple);
- number of shots or delay laws (one or multiple) per active aperture;
- type of delay law (beam steering, beam focusing or combined).

If multiple active apertures are used, then the same set of delay laws may be used for all active apertures, or a different set of delay laws may be used for each active apertures. The latter may be required to compensate for the orientation of the array relative to the object surface (wedge angle for contact technique, array tilt for immersion technique).

The verification tests for the different modes shall be performed as follows:

Mode 1

- Only one beam is created.
- Tests are performed with this beam.

Mode 2

- Multiple beams are created with the same active aperture.

- Tests are performed with a minimum of three beams corresponding to the extremes and median delay laws.

Mode 3

- Only applicable for an array parallel to the test surface.
- Multiple active apertures are used, all using the same delay law.
- Tests are performed with a minimum of one aperture.

Mode 4:

- Multiple active apertures are used, all using the same set of delay laws.
- Tests are performed with a minimum of one aperture and with a minimum of three beams corresponding to the extremes and median delay laws.

Mode 5

- Multiple active apertures are used, all using a single delay law but different for each active aperture.
- Alternatively, multiple active apertures are used, all using the same delay law, if the array is not parallel to the test surface.
- Tests are performed with a minimum of three apertures corresponding to the extreme and median positions.

Mode 6

- Multiple active apertures are used, each using a different set of delay laws.
- Tests are performed with a minimum of three apertures corresponding to the median and extreme positions and, for each of these apertures, on three beams corresponding to the extremes and median delay laws.

The modes are described and illustrated in [Table 3](#).

Table 3 — Modes of operation

| Modes | Number of active apertures | Number of delay laws per active aperture | Identical or different delay laws for each aperture | Examples |
|--|----------------------------|--|---|---|
| Mode 1 | One | One | Not applicable |  <p>Beam steering</p> |
| | | | Not applicable |  <p>Focusing on one point</p> |
| Mode 2 | One | Multiple | Not applicable |  <p>Sectorial electronic scanning</p> |
| | | | Not applicable |  <p>Focusing on several points</p> |
| <p>NOTE 1 For simplicity only the beam centre lines are indicated. An arrow indicates the beam direction, dots indicate focal points.</p> <p>NOTE 2 The medium between array and test object can be a fluid (immersion) or a solid (e.g. wedge).</p> | | | | |

Table 3 (continued)

| Modes | Number of active apertures | Number of delay laws per active aperture | Identical or different delay laws for each aperture | Examples |
|--|----------------------------|--|---|--|
| Mode 3 | Multiple | One | Identical beams for each aperture |  <p>Beam steering</p> |
| | | | Identical beams for each aperture |  <p>Focusing on one depth</p> |
| Mode 4 | Multiple | Multiple | Set of beams identical for each aperture |  <p>Sectorial electronic scanning</p> |
| | | | Set of beams identical for each aperture |  <p>Focusing on several points</p> |
| <p>NOTE 1 For simplicity only the beam centre lines are indicated. An arrow indicates the beam direction, dots indicate focal points.</p> <p>NOTE 2 The medium between array and test object can be a fluid (immersion) or a solid (e.g. wedge).</p> | | | | |

Table 3 (continued)

| Modes | Number of active apertures | Number of delay laws per active aperture | Identical or different delay laws for each aperture | Examples |
|--|----------------------------|--|---|---|
| Mode 5 | Multiple | One | Different for each aperture |  <p>Beam steering</p> |
| | | | Different for each aperture |  <p>Focusing on one depth</p> |
| Mode 6 | Multiple | Multiple | Set of beams different for each aperture |  <p>Sectorial electronic scanning</p> |
| | | | Set of beams different for each aperture |  <p>Focusing on several points</p> |
| <p>NOTE 1 For simplicity only the beam centre lines are indicated. An arrow indicates the beam direction, dots indicate focal points.</p> <p>NOTE 2 The medium between array and test object can be a fluid (immersion) or a solid (e.g. wedge).</p> | | | | |

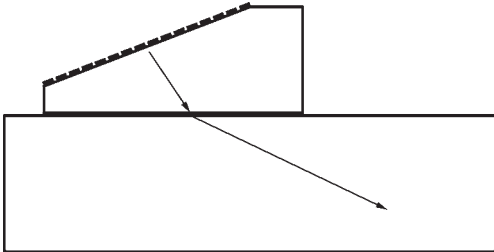
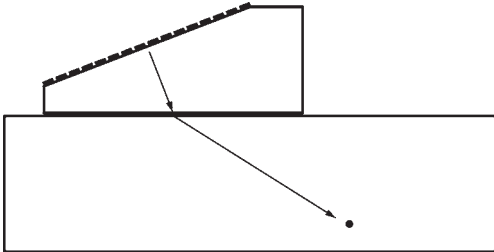
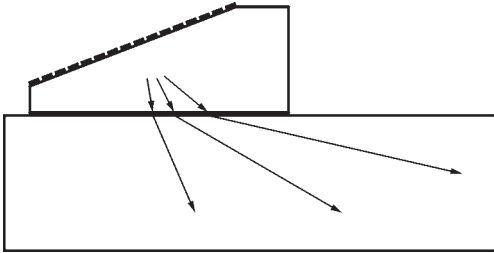
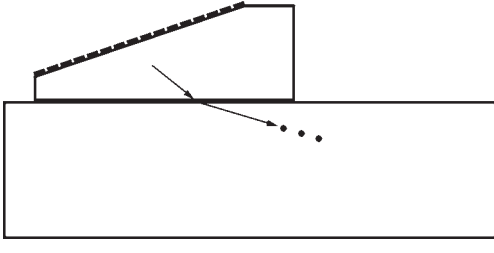
7 Equipment required for tests

The equipment required for the tests of the phased array system includes the following:

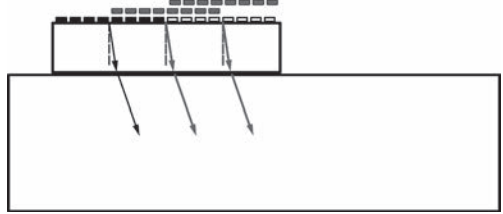
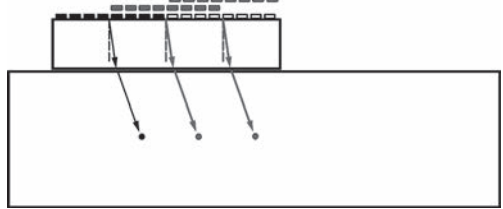
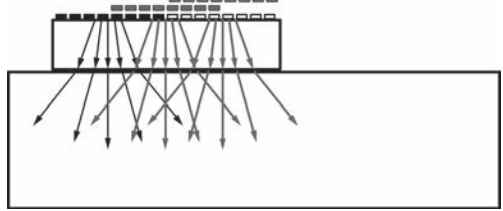
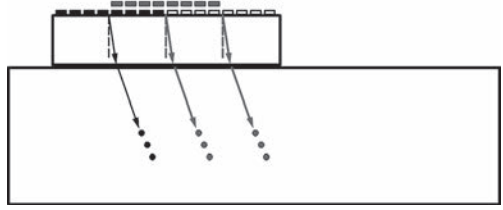
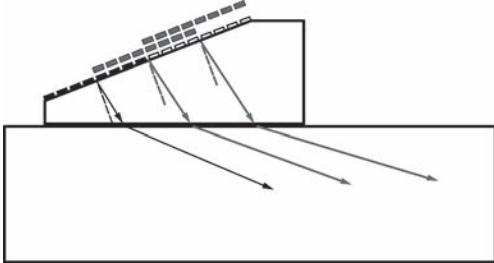
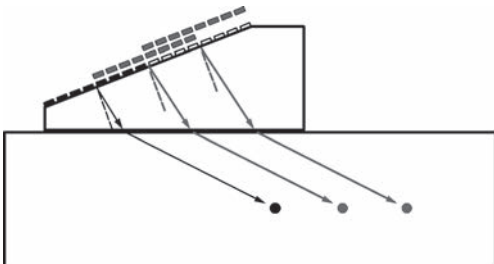
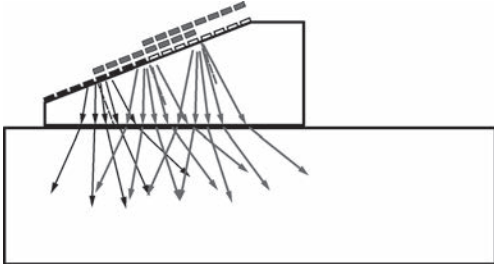
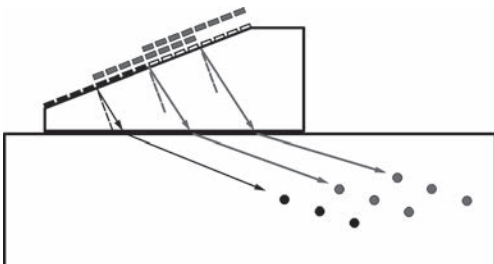
- suitable reference block(s);

EXAMPLE Size, curvature, material grade and/or sound velocity, dimensions of the block(s) and type, size and position of reflectors.

- means for measuring length and angle.

8 Group 1 tests

8.1 General

Group 1 tests are to be performed upon the system, initially, after a maintenance operation or after replacement of one of the system components.

For applications in which not all the elements of the probe are used, the tests can be limited to the elements of the used apertures only. In that case the results of the tested elements shall be recorded on the system record sheet.

Before performing the tests the equipment settings shall be made according to the array, wedge etc. that are in use.

8.2 Elements and channels

8.2.1 General

These tests are to ensure proper connection of the probe to the instrument and correct operation of the probe once connected.

The tests address

- the verification of channel/element assignment for transmission and reception, and the capability of the instrument to perform the electronic switching operations necessary to activate different apertures successively,
- the measurement of the relative sensitivity of the probe elements, and
- the identification of any failing component (e.g. dead elements).

If necessary, and if the instrument has the capability, these tests are followed by a compensation in amplitude of the elements.

8.2.2 Channel assignment

8.2.2.1 Operating procedure

For this test, it is necessary to use a planar reflecting surface that is tilted by a few degrees to the natural refracted beam axis in order to generate increasing time-of-flight values from element to element.

For the immersion technique, either tilt the array or tilt the reflector (a few degrees off perpendicular incidence).

For the contact technique:

- *without* a wedge, use a reference block with planar surfaces that are non-parallel;
- *with* a wedge,
 - 1) no reference block is needed if an echo from within the wedge is received for each element, or
 - 2) use a reference block with planar surfaces, where the impingement angle on the reflecting surface is at least a few degrees (see [Figure 1](#)).

Activate the elements one by one from the first element to the last element and compare the individual time-of-flight (e.g. A-scans, E-scans, time-of-flight values).

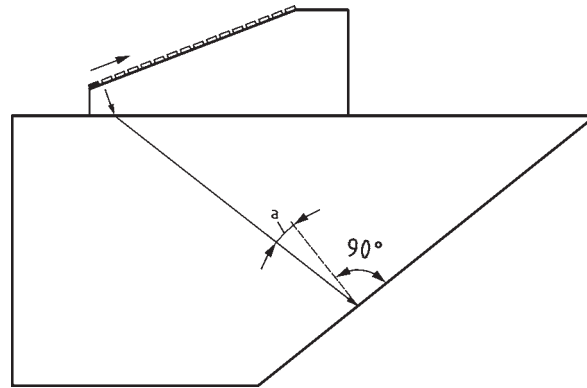

a Impingement angle.

NOTE The lines show only the centre line of the transmitted beam.

Figure 1 — Example of operating mode for verification of channel assignment in case of contact probe with wedge

8.2.2.2 Acceptance criteria

The longest time-of-flight shall be associated with the element farthest from the reflector; the shortest time-of-flight shall be associated with the echo corresponding to the element closest to the reflector. The time-of-flight of the received signals shall vary monotonically with element position.

8.2.3 Relative sensitivity of elements

8.2.3.1 General

The objective is to verify the relative sensitivity of the elements of the probe and to identify dead elements.

The test consists in activating successively each of the elements of the active aperture (transmit and receive with the same element) then measuring the variation in the amplitude of an echo generated by reflection on a planar surface equally distant from the various elements.

For contoured probe wedges, it is recommended to verify that the elementary channels are homogeneous without the wedge, if possible.

8.2.3.2 Operating procedures

8.2.3.2.1 Contact probes

The operating procedure for contact probes is as follows.

Position the probe on a reference block in order to obtain the same time-of-flight for all of the elements, e.g.:

- without a wedge, if possible;
- with a wedge, using a block of the same material with one side inclined at the same angle as the probe wedge;
- with a flat delay block, using the signals of the block surface (dry surface, no coupling fluid at the reflecting surface).

Activate the elements one by one (transmit and receive with the same element).

Display the amplitude of the echo from the reflector for each element.

Measure the amplitude A_{el} of each elementary signal.

8.2.3.2.2 Immersion probes

The operating procedure for immersion probes is as follows:

Position the probe in normal incidence in front of a reference block (made of steel, e.g.) with a planar surface.

Activate the elements one by one (transmit and receive with the same element).

Display the amplitude of the interface echo for each element; perpendicular incidence is obtained if all signals show an equivalent time-of-flight within a half-period tolerance.

Measure the amplitude A_{el} of the signal of each element.

8.2.3.3 Identification of dead elements

The relative sensitivity (in dB) of each element is calculated using Formula (1):

$$\Delta S_{el} = 20 \log (A_{el}/A_{mean}) \quad (1)$$

where

A_{el} the amplitude of the signal of a single element;

A_{mean} the mean value of the amplitudes of all signals (needs to be calculated);

ΔS_{el} relative sensitivity of an element.

An element is considered to be a dead element if

- a) $\Delta S_{el} < -12$ dB when the instrument is able to apply a compensation in gain on the elements,
- b) $\Delta \Delta S_{el} < -9$ dB when the instrument has no compensation circuit.

A drop in amplitude A_{el} can be caused by the array element, the cable and/or the instrument. Regardless of the reason, this shall be referred to as a *dead element*.

8.2.3.4 Calculation of reference sensitivity

The reference sensitivity A_{ref} is defined as the mean value of the amplitudes of the elementary signals excluding the dead elements. A_{ref} has to be calculated and reported on the system record sheet. A_{ref} is the reference amplitude for subsequent tests.

8.2.3.5 Compensation of sensitivity variation (amplitude balancing)

The compensation aims to reduce the variations in sensitivity between the elements. If the instrument has the capability, elementary amplitude compensation should be performed.

Every element showing a deviation in sensitivity greater than 3 dB (in absolute value) with respect to A_{ref} shall be compensated.

The compensation means changing elementary gain, limited to ± 12 dB, of any element which has shown a deviation in sensitivity more than 3 dB (in absolute value) with respect to the reference sensitivity A_{ref} .

Compensated elements together with their gain compensation shall be reported in the system record sheet.

8.2.3.6 Acceptance criteria

The number of dead elements on the same active aperture shall be a maximum of 1 out of 16 and the dead elements are not allowed to be adjacent.

8.3 Beam characterization

8.3.1 General

To verify that the phased array equipment is able to produce the beam(s) as intended, it is necessary to characterize at least the beam(s) according to the mode of operation as selected in [Clause 6](#). Due to the number of variables in settings for phased array technology, typically no data sheets for beam characterization are available as they are for conventional ultrasonic probes. Therefore reference values for beam characterization should be determined on a reference system. The items for beam characterization shall cover at least the items that are relevant for the operational use (application) of the equipment.

These tests shall be carried out

- a) after the tests of elements and channels upon a new system build-up,
- b) when a drift of the system characteristics is found during Group 2 tests.

In respect of a), If the beam characterization has already been performed on an identical system (see [3.4](#)), the characterization tests may be skipped on the new system. Indeed, the results obtained from the identical system may be used as a reference and the Group 2 tests carried out. The reference results shall be reported on the new system record sheet.

The characterization includes measurement of the following:

- probe index point (for contact probes) or point of incidence on the test object (for immersion probes);
- angle of refraction for angle-beam probes;
- sensitivity along the beam axis (e.g. distance-amplitude curve);
- beam dimensions in the area of interest;
- squint angle for contact probes;
- grating lobes (measurement or simulation recommended, if suspected).

Depending on the mode of operation, beam characterization is carried out on a subset of apertures and/or shots (see [Clause 6](#)).

Nevertheless, when the phased array probe includes dead elements, for Modes 3, 4, 5 and 6, it is necessary to characterize the beams of all the active apertures affected by the presence of those dead elements:

- for the shot concerned (Mode 3);
- for three shots corresponding to the extreme and median settings (Mode 4, 5 and 6).

These additional characterizations may be skipped in any of the following cases:

- the number of dead elements on the same active aperture is less than or equal to 1 out of 16 and the dead elements are not adjacent;
- a software simulation has provided evidence that for the given application the dead elements have no influence on the beams compared to the beams generated with all elements working properly;

- an experimental simulation of dead elements has been performed by switching off one or multiple elements and has shown that for the given application the dead elements have no influence on the beams compared to the beams generated with all elements working properly.

8.3.2 Absence of saturation

8.3.2.1 General

Prior to each test of the characterization of beams it is necessary to verify that elementary channels do not saturate.

There are two situations, as follows:

- If the instrument has an indication function for saturated channels, then this verification is not required. If saturation is indicated, the operator shall take appropriate measures to avoid saturation.
- If the instrument has no indication function for saturated channels, then the linearity of the sum of signals shall be verified (see [8.3.2.2](#)). A saturation of elementary channels leads to a distortion of the sum of signals and alters any quantitative measurement of amplitude; therefore, the absence of saturation is verified by checking the linearity of the sum of signals.

Verification of the absence of saturation shall be performed for the various active configurations and shots which require beam characterization and prior to all amplitude measurements made during this characterization.

8.3.2.2 Operating procedure

Set and note the transmitter voltage, apply the delay law to the active aperture, set and note the gain; position the probe to visualize the echo from the reflector considered. The reflector to be used for this test shall be similar to the reflector used in [8.3.3.3](#) or [8.3.4.3](#).

Adjust the gain so that the sum of signals corresponds to 80 % of full screen height.

Note the value of the calibrated gain control (dB).

Then increase the gain by 2 dB and confirm that the signal rises to slightly more than full screen height (101 %), if visible.

Retrieve the initial value of gain and decrease it by 6 dB then by an additional 6 dB.

Confirm that the signal drops to approximately 40 % then to 20 % of full screen height.

8.3.2.3 Acceptance criteria

For the case of [8.3.2.1 a\)](#), elementary signals shall not be saturated.

For the case of [8.3.2.1 b\)](#), the linearity of the sum of signals shall be consistent with [Table 4](#).

Table 4 — Acceptance criteria for the linearity of the sum of signals

| Gain setting dB | Amplitude on the screen % of full screen height | Acceptable amplitude % of full screen height |
|--------------------|--|---|
| + 2 | 101 | 95 minimum |
| 0 | 80 | Reference line |
| - 6 | 40 | from 37 to 43 |
| - 12 | 20 | from 17 to 23 |

If the criterion is not met, a solution may be to decrease the transmitter voltage.

8.3.3 Beam characterization for contact probes

8.3.3.1 General

Tests may be performed with devices for automated movements of the probe. Measurements are performed with the parameters identified for the application.

In some applications, several beams require characterization. These beams may be produced by the same set of parameters or may each require a separate setting. Depending on the settings available on the instrument used, this characterization phase may be performed by applying one set of parameters which produces all the beams or by successively applying the settings that will produce each beam.

Beam characterization may be done in one test for all the beams or in one test per beam.

For example, in the case of sectorial scanning, it is possible to characterize the beams corresponding to the extreme and median delay laws either

- by application of a single set of parameters corresponding to the sectorial scanning and carrying out measurements on each of the three beams of the sectorial scanning, or
- by application of three sets of parameters and carrying out measurements on each of the three beams.

In the case of probes with plane probe wedges, planar reference blocks shall be used.

In the case of contoured probe wedges, reference blocks with the same curvature shall be used.

8.3.3.2 Angle of refraction — Probe index point

8.3.3.2.1 General

For phased array probes, the probe index point position is not an intrinsic feature of the probe as it is for non-phased array contact probes.

Not only does the position of the probe index point vary from one active aperture to another but it may also vary with the delay laws applied for one aperture.

The probe index point and the angle of refraction shall be determined initially (then periodically, when performing stability tests).

8.3.3.2.2 Operating procedure

Two measurement methods are possible:

- a) determination of the probe index point first and then measuring the angle of refraction, a method that requires the use of a reference block with a quarter of a cylinder (see [Figure 2](#)) and a side-drilled hole (see [Figure 3](#));
- b) a method giving simultaneous access to the probe index point and to the angle of refraction, requiring the use of a reference block with side-drilled holes.

Depending on the method chosen, a block according to ISO 2400 or ISO 19675 may be used.

The most appropriate of the two methods shall be applied, as follows:

a) Determination of probe index point first, then angle of refraction

To determine the probe index point, a reference block featuring a quarter of a cylinder shall be used. For non-focused beams the radius of the cylinder shall be larger than the near field length of the active aperture considered. For focused beams the radius of the cylinder shall be in the range of the focal zone. The cylinder axis shall be marked on at least one side of the reference block as shown in [Figure 2](#).

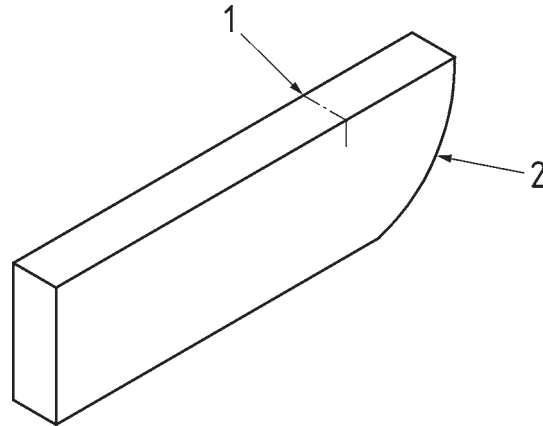
**Key**

- 1 cylinder axis
2 quarter of cylinder

Figure 2 — Reference block with quarter of cylinder and axis engraved

An estimation of the near field length N associated to the active aperture may be obtained using the standard formula, expressed in millimetres:

$$N = D^2/4\lambda = \frac{L^2 + W^2}{4\lambda} \quad (2)$$

where

- D is the diagonal of the active aperture in millimetres;
- L is the length of the active aperture in millimetres;
- W is the width of the active aperture in millimetres;
- λ is the wavelength in the material of the reference block in millimetres.

Adjust the position of the probe to maximize the echo from the cylindrical surface.

In this position, check for the absence of saturation of elementary signals (see 8.3.2); when no saturation is found, the probe index point coincides with the engraved centre line of the quarter of a cylinder.

Once the position of the probe index point has been found and noted (e.g. by marking the index point on the wedge), a reference block featuring a side-drilled hole at a known position shall be used to measure the angle of refraction. This block may bear on one side a scale of the radial angle to the centre of the hole (see Figure 3). For measurement of the beam angle the side-drilled hole shall be in the focal zone for focused beams. For unfocused beams the side-drilled hole shall be at the near field length or beyond.

Position the probe on the reference block and produce a signal from the side-drilled hole.

Move the probe backwards and forwards so as to maximize the amplitude of the signal. When the amplitude is at maximum, then the angle of refraction is determined either by calculation or by reading on the scale on the block below the measured probe index point.

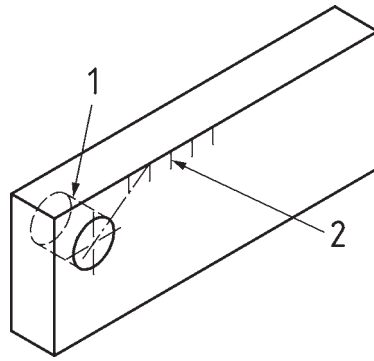

Key

- 1 side-drilled hole
- 2 scale of radial angles

Figure 3 — Reference block featuring a side-drilled hole and an angle scale on one side

b) Simultaneous determination of probe index point and angle of refraction

This requires the use of a reference block featuring at least four side-drilled holes at different depths (aligned vertically or not) (see [Figure 4](#)).

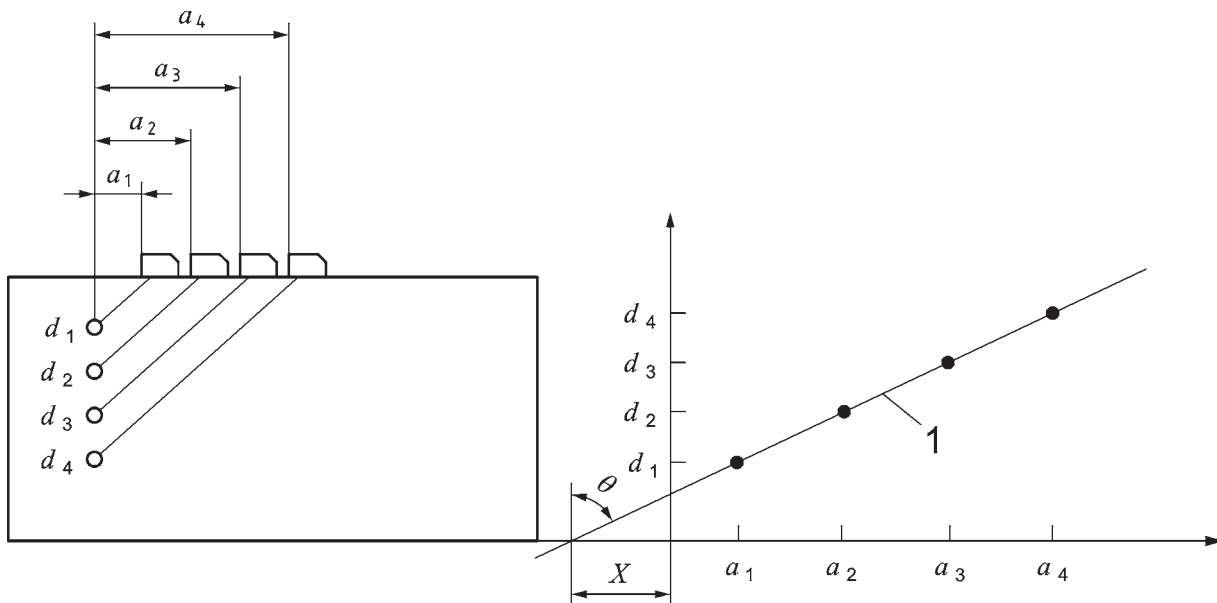

Key

- X distance between probe front surface and probe index point
- 1 slope = angle of refraction

Figure 4 — Principle of simultaneous measurement of angle of refraction and probe index point — Position of probe on reference block with four side-drilled holes and associated plot

Obtain the maximum amplitude for the direct echo from each hole, one after the other.

For each maximum amplitude echo, check for the absence of saturation of the elementary signals (see [8.3.2](#))

In each case, measure the distance (a_i) between the orthogonal projection of the axis of the hole and the front surface of the probe (with a ruler)

Plot the depth (d_i) of the holes against these distances (a_i) on a scale drawing of a section through the reference block and draw a straight line through the points,

Both the probe index and beam angle can thus be graphically determined simultaneously: The probe index point position corresponds to the distance X in [Figure 4](#) and the angle of refraction, θ , can be calculated using Formula (3):

$$\Theta = \text{Arctan} \left(\frac{a_i - a_1}{d_i - d_1} \right) \quad (3)$$

8.3.3.2.3 Reporting and acceptance criteria

The measurements are reported on the system record sheet.

The measured angle of refraction shall be within $\pm 2^\circ$ of the value specified in the settings of the delay laws. However, for angles of refraction greater than 65° , the measured angle shall be within $\pm 5^\circ$ of the specified value.

8.3.3.3 Sensitivity along the beam axis

8.3.3.3.1 General

The sensitivity along the beam axis shall be verified in the area of interest. If only one fixed distance will be used for testing, then this distance shall be used in the measurements in this clause.

For contact probes, the measurement is performed manually or with an automated scanning device, using equal reflectors at different distances, by recording the amplitudes of the echoes and the corresponding sound path.

If the instrument supports an automated recording of the sensitivity along the beam axis, like a distance-amplitude curve or an automated correction feature like time-corrected gain (TCG), this instrument feature may be used for the characterization of the beam.

Alternatively, the sensitivity along the beam axis may be measured and documented manually.

The measurements require the use of a reference block with reflectors in the area of interest. The recommended reflectors are side-drilled holes as shown in [Figure 5](#).

NOTE Flat reflectors (like flat-bottomed holes) are allowed but are less practical because they are only suitable for beam angles that impinge perpendicular on the reflector.

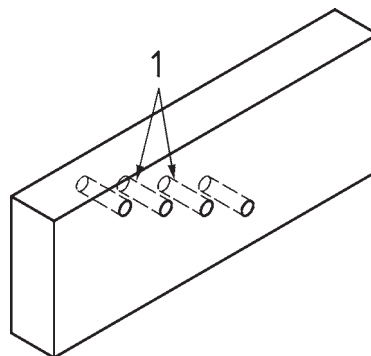

Key

1 side-drilled holes

Figure 5 — Example of reference block with equal diameter side-drilled holes

8.3.3.3.2 Operating procedure

Position the probe on the reference block so that its plane of incidence is perpendicular to the holes.

Move the probe over the reference block.

Adjust the gain to ensure that the maximum amplitude of the echo from any of the holes is at 80 % of FSH. Check for the absence of saturation of elementary signals.

Record the depth and/or sound path of the reflector that provides the maximum signal, record the value of the used gain G_{ref} on the system record sheet.

Position the probe on the reference block to obtain the maximum amplitude of each individual reflector.

8.3.3.3.3 Reporting

Measure and store the amplitudes or gain values and the corresponding sound paths as either

- distance-amplitude curve,
- time-corrected gain, or
- a table.

If beam focusing is used, determine the length of the focal zone at the -6 dB level.

8.3.3.4 Beam dimension

8.3.3.4.1 General

The beam is characterized by its dimensions in the plane perpendicular to the axis of the shot; these dimensions are measured in the plane of incidence and in the plane perpendicular to it (see [Figure 6](#)).

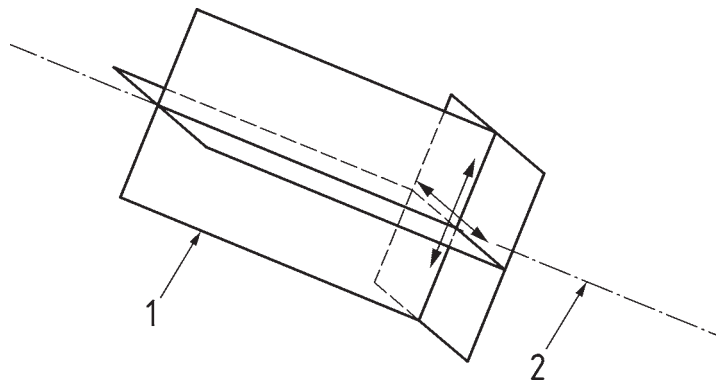

Key

- 1 plane of incidence
- 2 beam axis

Figure 6 — Focal spot dimensions

At least one measurement of the beam dimensions shall be carried out, in the zone of interest for the application. This measurement is performed automatically or manually by recording simultaneously the amplitudes of the echoes and the scanning movements of the probe. Two different methods can be used to characterize the beam shape:

- with a reference block featuring side-drilled holes;
- with a reference block featuring hemispherical-bottomed holes.

The first method only gives the beam dimension in the plane of incidence; the other gives the dimensions of the beam in the plane of incidence and the plane perpendicular to it.

8.3.3.4.2 Operating procedure

a) With reference block featuring side-drilled holes

A reference block with plane parallel sides with side-drilled holes at different distances (see [Figure 5](#)) may be used to measure the dimensions of the beam in the plane of incidence, as follows:

- 1) Position the probe on the reference block.
- 2) Move the probe on the reference block, so that its plane of incidence is perpendicular to the axes of the holes, in order to obtain echoes from these reflectors in the zone of interest for the application.
- 3) For the highest amplitude echo from the reflectors, check for the absence of saturation of elementary signals (see [8.3.2](#)).
- 4) For each reflector note the probe positions which produce a 6 dB amplitude drop. The dimension of the beam in the plane of incidence and perpendicular to the axis of the beam is obtained by multiplying the distance between the two positions by the cosine of the angle of refraction.

b) With reference block featuring hemispherical-bottomed holes

A reference block with plane parallel sides and featuring hemispherical-bottomed holes at different distances (see [Figure 7](#)) may be used to measure the dimensions of the beam in two perpendicular planes.

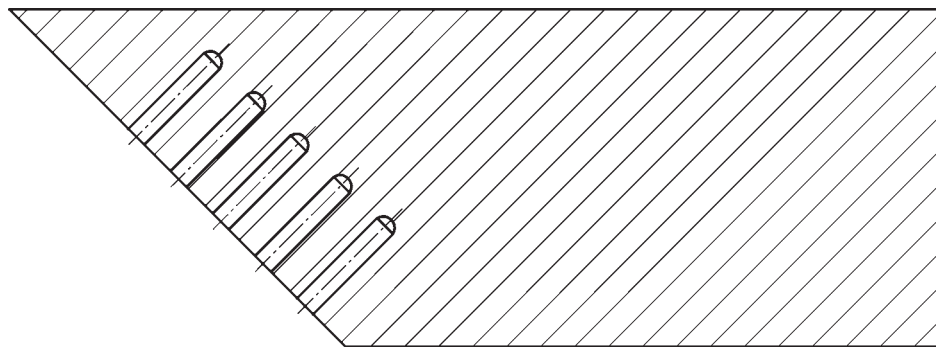

Figure 7 — Example for reference block featuring hemispherical-bottomed holes

The probe is moved in two perpendicular directions (front-rear and left-right) to obtain the dimensions of the beam, at the depth of the reflector considered.

The steps of the operating procedure are as follows:

- 1) Position the probe on the reference block.
- 2) Move the probe in scanning and increment over the block so as to obtain the echoes from the reflectors in the zone of interest for the application.
- 3) For the highest amplitude echo from the reflectors, check for the absence of saturation of elementary signals (see [8.3.2](#)).
- 4) For each reflector note the probe positions which produce a 6 dB amplitude drop. The dimension of the beam in the plane of incidence and perpendicular to the axis of the beam is obtained by multiplying the distance between the two positions by the cosine of the angle of refraction.

- 5) For each reflector determine the probe positions which produce a 6 dB amplitude drop in the direction perpendicular to the plane of incidence. The distance between these positions gives the dimension of the beam perpendicular to the plane of incidence (beam width).

8.3.3.4.3 Reporting

The measurements are reported in the system record sheet.

8.3.3.5 Squint angle

8.3.3.5.1 General

It is possible to use three different methods to evaluate the squint angle of the probe:

- using a reference block featuring side-drilled holes as described in EN 12668-2;
- using a reference block featuring a corner;
- using an electromagnetic-acoustic receiver as described in EN 12668-2.

8.3.3.5.2 Operating procedure

The described methods are used to maximize the signal from the selected reflector by swivelling the probe in order to measure the squint angle of the probe.

8.3.3.5.3 Reporting

The measurements are reported in the system record sheet.

8.3.3.6 Grating lobes (as recommended)

8.3.3.6.1 General

When $p > \lambda/2$ — λ being the wavelength in the first propagation medium and p the pitch of the array — grating lobes may be formed which can hinder detection or characterization by the main beam.

Therefore this test is recommended whenever $p > \lambda/2$ and when beam steering is required.

Several different methods can be used to evaluate the grating lobes of a beam:

- with a reference block featuring side-drilled holes;
- with an electromagnetic-acoustic receiver as described in EN 12668-2;
- using simulation software.

The procedure shall take into account the presence of grating lobes, the acceptance criteria depend on the application.

8.3.3.6.2 Operating procedure

The described methods are used to determine the signals from the selected reflector at different angles of the same beam.

Scan the probe over the surface of the reference block, or scan the cylindrical surface of the block with the electromagnetic-acoustic receiver and measure the signal received.

Plot the amplitude of the signal against the probe position, or the scanning angle of the electromagnetic-acoustic receiver.

Record the local maximum amplitudes and the associated angles.

8.3.3.6.3 Reporting

These measurements are recorded on the system record sheet.

8.3.4 Beam characterization for immersion probes

8.3.4.1 General

This section describes the tests to be performed for immersion probes.

The measurements are performed by applying the settings identified for the application.

In some applications, several beams have to be characterized. These beams may be produced by the same set of parameters or may require each a separate set of parameters. Depending on the settings offered by the instrument being used, the characterization phase may be performed by applying a set of parameters which produces all the beams or by applying successively the parameters each producing one beam.

For example, in the case of sectorial scanning, it is possible to characterize the beams corresponding to the extreme and median delay laws:

- either by applying one set of parameters corresponding to the sectorial scanning and on carrying out the measurements on each of the three beams of the sectorial scanning; or
- by applying successively three sets of parameters and carrying out the beam measurements for each set.

Before each measurement of a parameter, it is necessary to check for the absence of saturation of elementary signals ([8.3.2](#)).

8.3.4.2 Angle of refraction — Point of incidence on test object

8.3.4.2.1 General

The method proposed enables to obtain simultaneously the angle of refraction and the equivalent of the probe index point, i.e. here the intersection of the beam axis and the test object surface; this point is called the beam point of incidence on the test object. It requires the use of a reference block featuring at least four side-drilled holes at different depths as shown in [Figure 5](#).

8.3.4.2.2 Operating procedure

Position the probe in immersion above the reference block with side-drilled holes at the same angle and with the same sound path as the application considered.

Find for each hole the maximum value of the echo.

For the maximum amplitude echo from the side-drilled holes, check for the absence of saturation of elementary signals (see [8.3.2](#))

In each case, measure the distance (a_i) between the orthogonal projection of the axis of the hole and the centre of the probe surface

Plot the depth (d_i) of the holes against these distances (a_i) on a scale drawing of a section through the reference block and draw a straight line through the points; the beam point of incidence on the test piece and the angle of refraction can thus be determined simultaneously. The beam point of incidence on the

test piece corresponds to the distance X shown on [Figure 4](#) and the angle of refraction θ is calculated using Formula (4):

$$\Theta = \text{Arctan} \left(\frac{a_i - a_1}{d_i - d_1} \right) \quad (4)$$

8.3.4.2.3 Reporting and acceptance criteria

These measurements are reported on the system record sheet.

The measured angle of refraction shall be within $\pm 2^\circ$ of the value specified in the settings of the delay laws. However, for angles of refraction greater than 65° , the measured angle shall be within $\pm 5^\circ$ of the specified value.

8.3.4.3 Sensitivity along the beam axis

8.3.4.3.1 General

In immersion, the measurement is performed, for the active apertures considered, by simultaneously recording the amplitude of the echoes and the scanning movements of the probe. The measurements require the use of a reference block with reflectors of equal diameter at different depths within the area of interest. The reflectors shall be used to generate a distance–amplitude curve.

If the instrument supports an automated recording of the sensitivity along the beam axis, like a distance-amplitude curve or an automated correction feature like time-corrected gain (TCG), this instrument feature may be used for the characterization of the beam.

The recommended reflectors are side-drilled holes as shown in [Figure 5](#).

Flat reflectors (like flat-bottomed holes) may be used, but are less practical because they are only suitable for beam angles that impinge perpendicular on the reflector.

8.3.4.3.2 Operating procedure

Position the probe in immersion above the reference block with a water path equivalent to that of the application considered.

Move the probe in scanning above the block so that its plane of incidence is perpendicular to the generating lines of the cylindrical holes.

Verify that the maximum amplitude of the echo from all used reflectors is greater than 80 % of screen height; verify the absence of saturation of elementary signals, (see [8.3.2](#)).

Note the corresponding value of the gain; this value, G_{ref} recorded on the system record sheet will be the reference gain for the amplitude–distance measurements made later in the framework of the system stability.

Measure the maximum amplitude of each echo.

Draw the distance-amplitude curve by plotting these amplitudes against the depth of the corresponding reflectors.

Note the highest amplitude on the curve and the corresponding depth on the curve.

Measure on the curve the difference between the coordinates (depth) corresponding to a 6 dB decrease from the maximum; note the corresponding value which is the length of the focal zone.

8.3.4.3.3 Reporting and acceptance criterion

The distance-amplitude curve as well as the gain, G_{ref} , shall be reported on the system record sheet.

When parameters have been set in order to focus the beams, the maximum amplitude on the curve, the associated distance and the length of the focal zone are also recorded on the system record sheet.

The difference between the positions of the specified and the measured focal point along the beam axis shall be less or equal to half the measured length of the focal zone (see [Figure 8](#)).

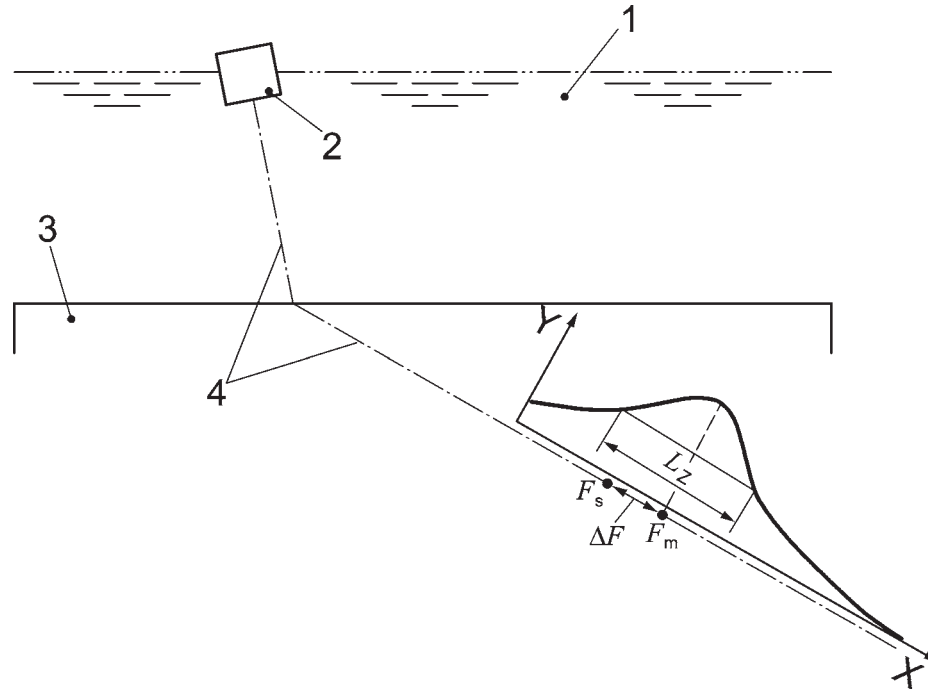

Key

- X distance
- Y amplitude
- L_z length of the focal zone (-6 dB)
- F_s position of the specified focal point
- F_m position of the measured focal point
- ΔF absolute value of difference between positions of specified and measured focal points along beam axis
- 1 coupling fluid
- 2 probe
- 3 test block
- 4 sound path along the beam axis

Figure 8 — Sensitivity along beam axis for focused beam

8.3.4.4 Beam dimensions

8.3.4.4.1 General

The measurement is performed for the active apertures considered by recording simultaneously the amplitude of the echoes together with the scanning movements of the probe. To characterize the shape of the beam the use of side-drilled or hemispherical-bottomed holes is recommended. Flat-bottomed holes may be used only if the diameter is much smaller than the beam to be measured.

The use of side-drilled holes only gives the dimensions of the beam in the plane of incidence.

8.3.4.4.2 Operating procedure

a) **With a reference block featuring side-drilled holes**

The operating procedure is similar to that given in [8.3.3.4.2 a\)](#), as follows.

- 1) Position the probe above the reference block.
- 2) Move the probe above the reference block, so that its plane of incidence is perpendicular to the axes of the holes, in order to obtain echoes from these reflectors in the operating zone of the probe.
- 3) For the highest amplitude echo from the reflectors, verify the absence of saturation of elementary signals (see [8.3.2](#)).
- 4) For each reflector, note the probe positions which produce a 6 dB amplitude drop. The dimension of the beam in the plane of incidence and perpendicular to the axis of the beam is obtained by multiplying the distance between the two positions by the cosine of the angle of refraction.

b) **Using a reference block with hemispherical-bottomed holes or flat-bottomed holes**

The operating procedure is similar to that given in [8.3.3.4.2 b\)](#), as follows. A reference block with plane parallel sides and reflectors at different distances (see [Figure 7](#)) may be used to measure the dimensions of the beam in two perpendicular planes.

- 1) Position the probe above the reference block.
- 2) Move the probe in scanning and increment above the block in order to obtain the echoes from the reflectors in the zone of interest for the application.
- 3) For the highest amplitude echo from the reflectors, check for the absence of saturation of elementary signals (see [8.2.2](#)).
- 4) For each reflector, note the probe positions which produce a 6 dB amplitude drop. The dimension of the beam in the plane of incidence and perpendicular to the axis of the beam is obtained by multiplying the distance between the two positions by the cosine of the angle of refraction.
- 5) For each reflector, determine the probe positions which produce a 6 dB amplitude drop in the direction perpendicular to the plane of incidence. The distance between these positions gives the dimension of the beam perpendicular to the plane of incidence (beam width).

8.3.4.4.3 Reporting

The measured beam dimensions are reported on the system record sheet.

8.4 Imaging check

8.4.1 General

Phased array systems offer the possibility to visualize acquisition data on reconstructed 2D images (e.g. E-scan presentations, S-scan presentations). These presentations are generated through algorithms specific to the system and therefore should be assessed.

The following tests should be performed with a suited reference block:

- verification of reflector positioning in the image compared to the positions in the reference block;
- verification of the -6 dB spot size in the image compared to the measured beam size;
- verification of the signal amplitudes in the image (colour coded) compared to the corresponding A-scan amplitudes;
- verification of the time-of-flight in the image compared to the corresponding A-scan.

8.4.2 Reflector positioning

8.4.2.1 Procedure

The verification of indication positioning in imaging (in all displayed dimensions) requires the use of a reference block featuring reflectors covering the area of interest (examples are shown in [Figure 5](#) and [Figure 7](#)).

Position the probe on a block so that the reconstructed 2D image makes it possible to visualize at least two reflectors at different depths in the area of interest.

Measure the positions of the reflectors given by imaging and the actual positions, calculate the deviations.

8.4.2.2 Reporting

Record the deviations on the system record sheet. These deviations give an order of magnitude of the performance of the system in terms of positioning of indications.

8.4.3 –6 dB spot size

8.4.3.1 Procedure

Move the probe so that its plane of incidence is perpendicular to the centre line of the holes in order to maximize the amplitude of the echo from a reflector in the median shot [side-drilled hole or flat-bottomed hole, see [8.3.3.4.2 a\)](#) or [8.3.3.4.2 b\)](#)].

Measure the size of the –6 dB spot in the image, perpendicularly to the axis of median shot.

8.4.3.2 Reporting

Note the deviation between the size of the beam measured on the shot corresponding to the median delay law and the size of the echo at –6 dB on the system record sheet.

8.4.4 Amplitude comparison

8.4.4.1 Procedure

Move the probe so that its plane of incidence is perpendicular to the centre line of the holes in order to maximize the amplitude of the echo from a reflector in the median shot [side-drilled hole or flat-bottomed hole, see [8.3.3.4.2 a\)](#) or [8.3.3.4.2 b\)](#)].

Determine the value of the maximum amplitude in the A-scan and compare to the amplitude value in the image.

8.4.4.2 Reporting

Note the deviation between the amplitude measured in the A-scan and the amplitude in the image on the system record sheet.

9 Group 2 tests

9.1 General

These checks confirm that the following characteristics show no drift with time:

- general condition and aspect;
- relative sensitivity of elements;

- linearity of the amplification system;
- absolute sensitivity of virtual probes;
- relative sensitivity of virtual probes;
- probe index point for contact probes;
- angles of refraction for contact probes;
- squint angle for contact probes.

If the tests of Group 2 are performed immediately after the tests of Group 1, then the identical tests, as mentioned in the footnote to [Table 2](#), need not be carried out again.

The verification of parameters makes reference to the results obtained after the latest phase of beam characterization previously performed on the system or on an identical system (see [3.4](#)).

When a parameter no longer meets the acceptance criteria, a complete characterization shall be launched in accordance with [Clause 8](#) unless the initial tests took into account these deviations and have been evaluated (see [9.3.5](#)).

9.2 Visual inspection of equipment

9.2.1 Operating procedure

Visually inspect the ultrasonic phased array instrument from outside, the probes, the cables and the connectors in order to detect any sign of damage or wear that may affect both the current operation of the system and its long term reliability.

Particularly, inspect the probe wedge. If the probe is made out of various components, verify that they are correctly assembled.

9.2.2 Acceptance criteria

The wedge shall have no mechanical damage that influences the beam characteristics.

The cable connections shall be in good condition.

9.3 Relative sensitivity of elements

9.3.1 General

The test is intended at verifying that the possible occurrence of changes in the relative sensitivity of the elements has no influence on the correct operation of the system; when necessary, corrective actions shall be taken.

Note that the relative sensitivity of elements varies from probe to probe, so differences between the tested system and the reference system can occur.

During this test, compensation of elements shall be upgraded when necessary and if the ultrasonic phased array instrument enables it. When one or more elements are considered dead, a complete characterization of the beam may have to be repeated.

9.3.2 Operating procedure

The measurement of the sensitivity of the various elements included in any active aperture shall be performed according to [8.2.3.2](#) with the same parameters as for the Group 1 test.

9.3.3 Identification of dead elements

A new A_{mean} shall be calculated and reported.

An element is considered a dead element, if

- a) $\Delta S_{\text{el}} < -12$ dB, when the instrument is able to apply a compensation in gain on the elements;
- b) $\Delta S_{\text{el}} < -9$ dB, when the instrument has no compensation circuit.

9.3.4 Compensation of sensitivity variation

Any element showing a deviation in sensitivity from the value A_{mean} greater than 3 dB (in absolute value) shall be compensated in accordance with [8.2.3.5](#), if the ultrasonic phased array instrument makes it possible.

When compensation is not possible and if the elements showing a deviation in sensitivity greater than 3 dB from the mean value are different from those having been noted during the previous characterization phase, then it is recommended to carry out a new characterization of beams on the affected active apertures.

9.3.5 Acceptance criteria

The presence of one or several new dead elements imposes re-launching a complete characterization of beams on the affected active apertures according to [8.2](#), unless

- a) a simulation has provided evidence that the failure of these elements had no measurable influence on the characterization of beams, or
- b) the number of dead elements on the same active aperture is less than or equal to 1 out of 16 and the dead elements are not adjacent.

A drop between the new A_{mean} and A_{ref} greater than 6 dB is only acceptable if the signal-to-noise ratio for the application is acceptable. Otherwise, a maintenance operation shall be carried out.

9.4 Linearity of amplification system

9.4.1 Operating procedure

Position the probe on a calibration block (or above, when in immersion) and define an active aperture enabling to obtain a signal reflected from a small reflector.

Adjust the gain to set the signal to 80 % of full screen height then note the value G_0 of the calibrated gain control (dB).

Decrease the gain G_0 by 6 dB and confirm that the signal falls down to 40 % of full screen height.

Decrease the gain by an additional 6 dB increment and confirm that the amplitude of the signal falls to 20 % of full screen height.

9.4.2 Acceptance criteria

See [Table 5](#).

Table 5 — Acceptance levels for vertical display linearity

| Gain setting dB | Amplitude on the screen % of full screen height | Acceptable amplitude % of full screen height |
|--------------------|--|---|
| + 2 | 101 | 95 minimum |
| 0 | 80 | Reference line |
| -6 | 40 | from 37 to 43 |
| -12 | 20 | from 17 to 23 |

9.5 Absolute sensitivity of virtual probes

9.5.1 General

This test verifies the absolute sensitivity of the system to show any drift. Measurements have to be performed according to [8.3.3.3](#) or [8.3.4.3](#) and are then be compared to previous measurements.

9.5.2 Operating procedure

Apply the settings and reference block(s) which were used in [8.3.3.3.2](#) or [8.3.4.3.2](#) respectively.

Select the reflector delivering the highest echo amplitude.

Adjust the gain to set the amplitude of the echo from that reflector to 80 % of FSH and this gain value shall be recorded.

Compare this gain to G_{ref} measured in [8.3.3.3.2](#) or [8.3.4.3.2](#) respectively.

9.5.3 Acceptance criterion

The gain used should not vary by more than ± 4 dB from G_{ref} .

A drop between the gain used and G_{ref} greater than 4 dB is only acceptable, if the signal-to-noise ratio for the application is acceptable. Otherwise a maintenance operation shall be carried out.

9.6 Relative sensitivity of virtual probes

9.6.1 General

This test is performed for Mode 3 and 4 to check the uniform sensitivity of all virtual probes using the same delay law. Only one selected delay law has to be used.

9.6.2 Operating procedure

The test requires a reference block with at least two reflectors of the same type and size at different depths in the area of interest.

The probe has to be moved across a first reflector to get the amplitudes of the echoes from this reflector received by all virtual probes used. The result has to be recorded on the system record sheet.

If the instrument has the capability, the normalization of virtual probes should be performed.

Then the probe has to be moved across the other reflector(s) to get the amplitudes of the echoes from this reflector(s) received by all virtual probes used. The result has to be recorded on the system record sheet.

9.6.3 Acceptance criterion

After normalization all of the virtual probes using the same delay law shall show amplitudes within ± 2 dB of the mean amplitude response at each depth of the reflectors.

For the following periodic checks applying the previous normalization the same criterion applies.

If no normalization is applied the results shall be taken into account when using the system.

9.7 Probe index points

9.7.1 General

These tests have to be performed after a verification of the absence of saturation of elementary channels.

A verification of the probe index points is to be performed in the case of contact probes. It is intended for verifying that the possible occurrence of wear on the probe wedge or the occurrence of dead elements, previously identified, has no influence on the characteristics of the beam.

Therefore:

- in the *absence* of dead elements, the probe index point shall be measured on one shot of one of the active apertures of the configuration considered;
- in the *presence* of dead elements, the probe index point shall be measured on one shot of each of the affected active apertures of the configuration considered.

In the presence of dead elements, only one measurement may be carried out in either of the following cases:

- a) a simulation has provided evidence that the failure of these elements had no measurable influence on the characterization of beams;
- b) the number of dead elements on the same active aperture is less than or equal to 1 out of 16 and the dead elements are not adjacent.

9.7.2 Operating procedure

Measurement of the probe index points is to be performed following the procedure in [8.2.3.2](#).

9.7.3 Acceptance criteria

The probe index point shall fall within ± 1 mm from the point initially reported on the system record sheet.

For angle probes in which the size of the active aperture is less than or equal to 15 mm and the frequencies are less than or equal to 2 MHz, the position of the probe index point shall be measured with a tolerance of ± 2 mm compared to the value initially reported on the system record sheet.

9.8 Angle(s) of refraction

9.8.1 General

A verification of the absence of saturation of elementary channels shall first be carried out.

A verification of the angles of refraction shall be performed in all the cases.

This is intended to verify the influence of possible dead elements previously identified.

For contact probes, the test is also intended to verify that a possible wear of the probe wedge has no influence on the characteristics of the beam.

For immersion probes, the test is also intended to verify that a possible drift of the positioning system has no influence on the characteristics of the beam.

Therefore:

- in the *absence* of dead elements, the angle of refraction shall be measured on one shot of one of the active apertures of the configuration considered;
- in the *presence* of dead elements, the angle of refraction shall be measured on one shot of each of the affected active apertures of the configuration considered.

In the presence of dead elements, only one measurement may be carried out in either of the following cases:

- a) a simulation has provided evidence that the failure of these elements had no measurable influence on the characterization of beams;
- b) the number of dead elements on the same active aperture is less than or equal to 1 out of 16 and the dead elements are not adjacent.

9.8.2 Operating procedure

The measurement of the angle shall be performed in accordance with [8.3.3.2](#) or [8.3.4.2](#), according to the test technique, contact or immersion.

9.8.3 Acceptance criterion

The measured angle of refraction shall be within $\pm 2^\circ$ of the value specified in the settings of the delay laws. However, for angles of refraction greater than 65° , the measured angle shall be within $\pm 5^\circ$ of the specified value.

9.9 Squint angle for contact probes

9.9.1 General

Three different methods can be used to evaluate the squint angle of the probe:

- with a reference block featuring side-drilled holes as described in EN 12668-2;
- with a reference block featuring a corner;
- using an electromagnetic-acoustic receiver as described in EN 12668-2.

9.9.2 Operating procedure

The described methods are used to maximize the signal from the selected reflector by swivelling the probe in order to measure the squint angle of the probe.

9.9.3 Reporting

The measurements are to be reported in the system record sheet ([Clause 10](#)).

10 System record sheet

The system record sheet shall include at least the following information:

- a) measurement results;
- b) date of testing;

- c) type and serial number of equipment (instrument, probe and cable);
- d) reference block(s) used;
- e) software version;
- f) mode of operation;
- g) tested beam parameters/settings;
- h) name and signature of operator.

Annex A (informative)

Tests to be performed and their acceptance criteria

See [Table A.1](#).

Table A.1 — Tests to be performed and their acceptance criteria

| | Contact probe | Immersion probe | Reporting and criteria |
|---|-------------------------|-------------------------|--|
| Group 1 tests | | | |
| Elements and channels | | | |
| Channel assignment | 8.2.2 | 8.2.2 | The longest time-of-flight shall be associated with the element farthest from the reflector; the shortest time-of-flight shall be associated with the echo corresponding to the element closest to the reflector. The time-of-flight of the received signals shall vary monotonically with element position. |
| Relative sensitivity of elements | 8.2.3 | 8.2.3 | The number of dead elements on the same active aperture shall be a maximum of 1 out of 16 and the dead elements are not allowed to be adjacent. |
| Beam characterization | | | |
| Absence of saturation | 8.3.2 | 8.3.2 | For the sum of signals the linearity has to be $\pm 3\%$ for +2 dB, -6 dB and -12 dB, reference at 80 %. |
| Probe index point | 8.3.3.2 | | Reporting on system record sheet. |
| Angle of refraction | 8.3.3.2 | | Reporting on system record sheet. The measured angle of refraction shall be within $\pm 2^\circ$ of the value specified in the settings of the delay laws. However, for angles of refraction greater than 65° , the measured angle shall be within $\pm 5^\circ$ of the specified value. |
| Angle of refraction – point of incidence on the test object | | 8.3.4.2 | Reporting on system record sheet. The measured angle of refraction shall be within $\pm 2^\circ$ of the value specified in the settings of the delay laws. However, for angles of refraction greater than 65° , the measured angle shall be within $\pm 5^\circ$ of the specified value. |
| Sensitivity along the beam axis | 8.3.3.3 | 8.3.4.3 | Reporting on record sheet (contact probe). The distance-amplitude curve as well as the gain G_{ref} is recorded on the system record sheet (immersion probe). |
| Beam dimensions | 8.3.3.4 | 8.3.4.4 | Reporting on system record sheet. |
| Squint angle | 8.3.3.5 | | Reporting on system record sheet. |
| Grating lobes (recommended) | 8.3.3.6 | | Reporting on system record sheet. |
| Imaging check | | | |
| Reflector positioning | 8.4.2 | 8.4.2 | Reporting on system record sheet. |
| -6 dB spot size | 8.4.3 | 8.4.3 | Reporting on system record sheet. |
| Amplitude comparison | 8.4.4 | 8.4.4 | Reporting on system record sheet. |
| Group 2 tests | | | |

Table A.1 (continued)

| | Contact probe | Immersion probe | Reporting and criteria |
|---|---------------------|---------------------|--|
| Visual inspection of the equipment | 9.2 | 9.2 | The wedge has no mechanical damage that influences the beam characteristics. The cable connections are in good condition. |
| Relative sensitivity of elements | 9.3 | 9.3 | The presence of one or several new dead elements imposes re-launching a complete characterization of beams on the affected active apertures according to 8.2 , unless a) a simulation has provided evidence that the failure of these elements had no measurable influence on the characterization of beams, or b) the number of dead elements on the same active aperture is less than or equal to 1 out of 16 and the dead elements are not adjacent. A drop between the new A_{mean} and A_{ref} greater than 6 dB is only acceptable if the signal-to-noise ratio for the application is acceptable. Otherwise, a maintenance operation is carried out. |
| Linearity of the amplification system | 9.4 | 9.4 | For the sum of signals the linearity has to be $\pm 3\%$ for +2 dB, -6 dB and -12 dB, reference at 80 %. |
| Absolute sensitivity of the virtual probe | 9.5 | 9.5 | The gain used should not vary by more than ± 4 dB from G_{ref} . A drop between the gain used and G_{ref} greater than 4 dB is only acceptable if the signal-to-noise ratio for the application is acceptable. Otherwise, a maintenance operation is carried out. |
| Relative sensitivity of the virtual probe | 9.6 | 9.6 | After normalization all of the virtual probes using the same delay law show amplitudes within ± 2 dB of the mean amplitude response at each depth of the reflectors. If no normalization is applied the results are taken into account when using the system. |
| Probe index points | 9.7 | | The probe index point falls within ± 1 mm from the point initially reported on the system record sheet. For angle-beam probes in which the size of the active aperture is less than or equal to 15 mm and the frequencies are less than or equal to 2 MHz, the position of the probe index point is measured with a tolerance of ± 2 mm compared to the value initially reported on the system record sheet. |
| Angle(s) of refraction | 9.8 | 9.8 | The measured angle of refraction is within $\pm 2^\circ$ of the value specified in the settings of the delay laws. However, for angles of refraction greater than 65° , the measured angle is within $\pm 5^\circ$ of the specified value. |
| Squint angle | 9.9 | | The measurements are reported in the system record sheet. |

Bibliography

- [1] ISO 2400, *Non-destructive testing — Ultrasonic testing — Specification for calibration block No. 1*
- [2] ISO 7963, *Non-destructive testing — Ultrasonic testing — Specification for calibration block No. 2*
- [3] ISO 19675, *Non-destructive testing — Ultrasonic testing — Specification for a calibration block for phased array testing (PAUT)*¹⁾
- [4] EN 12668-2, *Non-destructive testing — Characterization and verification of ultrasonic examination equipment — Part 2: Probes*

1) To be published.

