**Gasoline engines — Medium pressure
liquid fuel supply connections —**

**Part 1:
60° female cone connectors**

*Moteurs à essence — Connexions pour des lignes de combustible
liquide à moyenne pression —*

Partie 1: Raccords à cônes femelle de 60°





COPYRIGHT PROTECTED DOCUMENT

© ISO 2016, Published in Switzerland

All rights reserved. Unless otherwise specified, no part of this publication may be reproduced or utilized otherwise in any form or by any means, electronic or mechanical, including photocopying, or posting on the internet or an intranet, without prior written permission. Permission can be requested from either ISO at the address below or ISO's member body in the country of the requester.

ISO copyright office
Ch. de Blandonnet 8 • CP 401
CH-1214 Vernier, Geneva, Switzerland
Tel. +41 22 749 01 11
Fax +41 22 749 09 47
copyright@iso.org
www.iso.org

Contents

	Page
Foreword	iv
Introduction	v
1 Scope	1
2 Normative references	1
3 Terms and definitions	1
4 Requirements	1
4.1 Dimensions and tolerances	1
4.2 Materials	3
5 Operating pressure	3
6 Designation	3
Bibliography	4

Foreword

ISO (the International Organization for Standardization) is a worldwide federation of national standards bodies (ISO member bodies). The work of preparing International Standards is normally carried out through ISO technical committees. Each member body interested in a subject for which a technical committee has been established has the right to be represented on that committee. International organizations, governmental and non-governmental, in liaison with ISO, also take part in the work. ISO collaborates closely with the International Electrotechnical Commission (IEC) on all matters of electrotechnical standardization.

The procedures used to develop this document and those intended for its further maintenance are described in the ISO/IEC Directives, Part 1. In particular the different approval criteria needed for the different types of ISO documents should be noted. This document was drafted in accordance with the editorial rules of the ISO/IEC Directives, Part 2 (see www.iso.org/directives).

Attention is drawn to the possibility that some of the elements of this document may be the subject of patent rights. ISO shall not be held responsible for identifying any or all such patent rights. Details of any patent rights identified during the development of the document will be in the Introduction and/or on the ISO list of patent declarations received (see www.iso.org/patents).

Any trade name used in this document is information given for the convenience of users and does not constitute an endorsement.

For an explanation on the meaning of ISO specific terms and expressions related to conformity assessment, as well as information about ISO's adherence to the World Trade Organization (WTO) principles in the Technical Barriers to Trade (TBT) see the following URL: www.iso.org/iso/foreword.html.

The committee responsible for this document is ISO/TC 22, *Road vehicles*, Subcommittee SC 34, *Propulsion, powertrain, and powertrain fluids*.

This second edition cancels and replaces the first edition (ISO 18418-1:2014), which has been technically revised.

A list of all parts in the ISO 18418 series can be found on the ISO website.

Introduction

Some spark ignition (SI) engines use direct injection (DI) fuel systems which supply gasoline under pressure to a rail and to the injectors via pipe assemblies with a 60° female cone connector. Such components are similar to ISO 2974 and ISO 13296 for the diesel injection systems, except for the relationship between the outside and inside diameters of the pipes due to the lower pressure range.

Connectors defined either in ISO 2974 or in this document can be used.

Gasoline engines — Medium pressure liquid fuel supply connections —

Part 1: 60° female cone connectors

1 Scope

This document specifies the dimensional requirements of medium-pressure pipe end-connections for gasoline (spark ignition) engine fuel injection equipment.

It is applicable to externally threaded end-connections having a 60° female cone (see [Figure 1](#)), as well as to the pipe end assemblies of medium-pressure fuel injection pipes with outside diameters of up to and including 10 mm (see [Table 1](#)).

2 Normative references

The following documents are referred to in the text in such a way that some or all of their content constitutes requirements of this document. For dated references, only the edition cited applies. For undated references, the latest edition of the referenced document (including any amendments) applies.

ISO 261, *ISO general purpose metric screw threads — General plan*

3 Terms and definitions

No terms and definitions are listed in this document.

ISO and IEC maintain terminological databases for use in standardization at the following addresses:

- IEC Electropedia: available at <http://www.electropedia.org/>
- ISO Online browsing platform: available at <http://www.iso.org/obp>

4 Requirements

4.1 Dimensions and tolerances

[Figure 1](#) indicates the basic requirements for the end-connection at the rail, at the fuel injection pump, and at the injector to allow interchangeability for medium-pressure fuel injection pipe assemblies.

The 60° female cone and its relationship to the external thread of the end-connection shall meet the requirements of [Figure 1](#).

It is important that the dimensions and tolerances are valid after the final assembly (heat treating, brazing, welding) of the end-connection to the rail, the pump, or the injector and prior to the assembly of the pipe.

Dimensions and tolerances are given in [Table 1](#). Unspecified details are left to the manufacturer's choice.

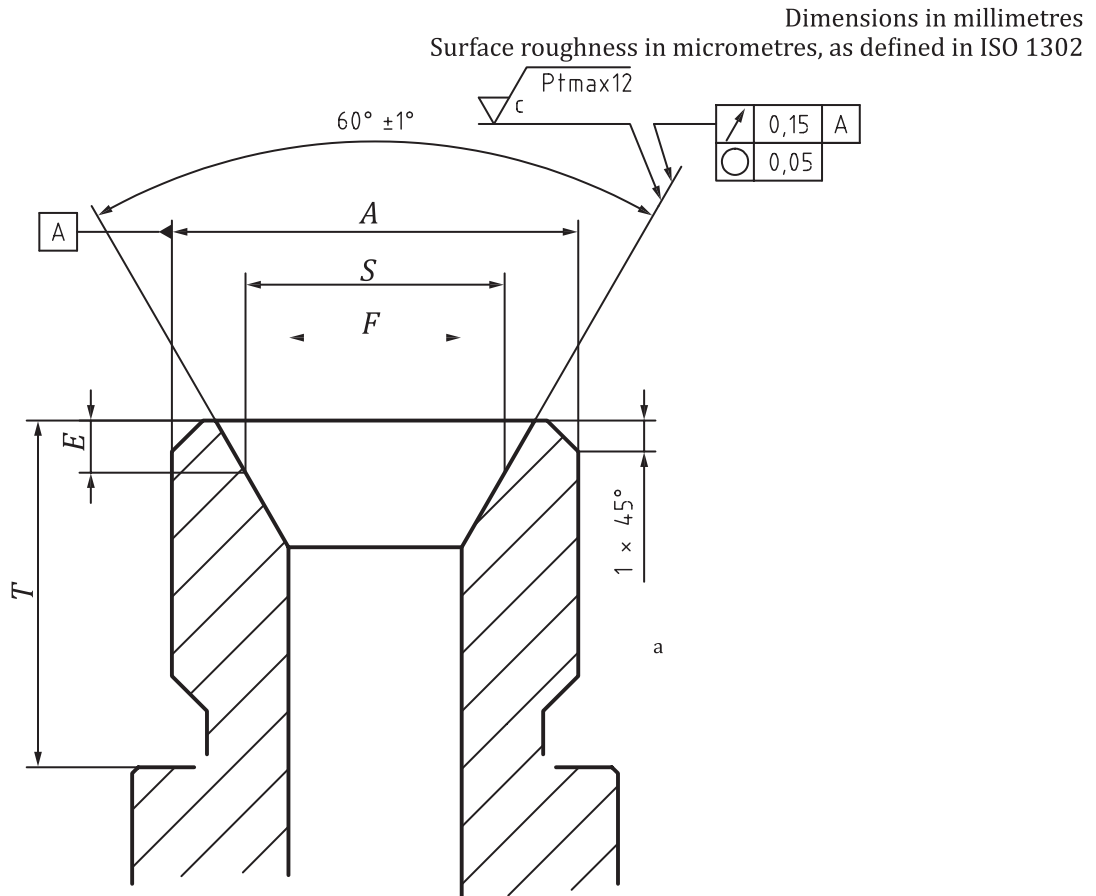

Key

- A* thread
- S* reference diameter
- E* depth of reference diameter plane
- F* bore diameter
- T* connector length
- ^a Undercut: design according to agreement between customer and supplier maintaining a minimum thread engagement of 3x pitch when assembled with pipe end nut.

NOTE 1 See [Table 1](#) for dimensions of *A*, *S*, *E*, *F*, and *T*.

NOTE 2 All non-dimensioned edges $\sqrt{-0,2}$.

Figure 1 — End-connector with integral 60° female cone

Table 1 — 60° female cones

Dimension in millimetres

Tube outside diameter	Thread ^a <i>A</i>	Reference diameter <i>S</i>	Bore diameter <i>F</i> max.	Depth of reference diameter plane <i>E</i>	Connector length <i>T</i> min.
8	M14 × 1,5	8,5	6,1	2,2 ± 0,08	11
10	M16 × 1,5	8,5	8,1	3,9 ± 0,08	11

^a Tolerance classes of threads 6 g for external threaded end-connection.

4.2 Materials

The specification of material and heat treatment shall be made according to the intended use.

5 Operating pressure

The permissible operating pressure shall be specified with an adequate safety margin to ensure the sealing of the joint under maximum internal pressure and shall be agreed upon between supplier and customer.

6 Designation

An end-connection conforming to this document shall be designated by the following elements, in the order given:

- a) a reference to this document, i.e. ISO 18418-1;
- b) the tube outside diameter, in millimetres (mm);
- c) the thread designation, in accordance with ISO 261.

EXAMPLE An end-connection of pipe outside diameter 8 mm, with an M14 thread is designated:

ISO 18418-1 - M14

Bibliography

- [1] ISO 1302, *Geometrical Product Specifications (GPS) — Indication of surface texture in technical product documentation*
- [2] ISO 2974, *Diesel engines — 60 degree female cones for high-pressure fuel injection components*
- [3] ISO 3508, *Thread run-outs for fasteners with thread in accordance with ISO 261 and ISO 262*
- [4] ISO 13296, *Diesel engines — High-pressure fuel injection pipe assemblies — General requirements and dimensions*
- [5] ISO 18418-2, *Gasoline engines — Medium pressure liquid fuel supply connections — Part 2: Pipe assemblies*

