

INTERNATIONAL
STANDARD

ISO
18391

First edition
2016-10-01

Geometrical product specifications (GPS) — Population specification

*Spécification géométrique des produits (GPS) — Spécification de
population*



Reference number
ISO 18391:2016(E)

© ISO 2016



COPYRIGHT PROTECTED DOCUMENT

© ISO 2016, Published in Switzerland

All rights reserved. Unless otherwise specified, no part of this publication may be reproduced or utilized otherwise in any form or by any means, electronic or mechanical, including photocopying, or posting on the internet or an intranet, without prior written permission. Permission can be requested from either ISO at the address below or ISO's member body in the country of the requester.

ISO copyright office
Ch. de Blandonnet 8 • CP 401
CH-1214 Vernier, Geneva, Switzerland
Tel. +41 22 749 01 11
Fax +41 22 749 09 47
copyright@iso.org
www.iso.org

Contents

Page

Foreword	iv
Introduction	v
1 Scope	1
2 Normative references	1
3 Terms and definitions	1
4 Rules for establishing a population specification	3
4.1 General.....	3
4.2 Rules.....	3
4.2.1 Rule 1: Description of a population specification.....	3
4.2.2 Rule 2: Description of type of individual GPS specification (univariate or multivariate).....	5
4.2.3 Rule 3.....	7
5 Symbol used to specify a population specification	8
6 Rules for indicating a population specification	11
Annex A (informative) Relation in the GPS matrix model	15
Bibliography	16

Foreword

ISO (the International Organization for Standardization) is a worldwide federation of national standards bodies (ISO member bodies). The work of preparing International Standards is normally carried out through ISO technical committees. Each member body interested in a subject for which a technical committee has been established has the right to be represented on that committee. International organizations, governmental and non-governmental, in liaison with ISO, also take part in the work. ISO collaborates closely with the International Electrotechnical Commission (IEC) on all matters of electrotechnical standardization.

The procedures used to develop this document and those intended for its further maintenance are described in the ISO/IEC Directives, Part 1. In particular the different approval criteria needed for the different types of ISO documents should be noted. This document was drafted in accordance with the editorial rules of the ISO/IEC Directives, Part 2. www.iso.org/directives

Attention is drawn to the possibility that some of the elements of this document may be the subject of patent rights. ISO shall not be held responsible for identifying any or all such patent rights. Details of any patent rights identified during the development of the document will be in the Introduction and/or on the ISO list of patent declarations received. www.iso.org/patents

Any trade name used in this document is information given for the convenience of users and does not constitute an endorsement.

For an explanation on the meaning of ISO specific terms and expressions related to conformity assessment, as well as information about ISO's adherence to the WTO principles in the Technical Barriers to Trade (TBT), see the following URL: [Foreword - Supplementary information](#)

The committee responsible for this document is ISO/TC 213, *Dimensional and geometrical product specifications and verification*.

Introduction

This International Standard is a Geometrical Product Specification (GPS) standard and is to be regarded as a global GPS standard (see ISO 14638). It influences all chain links of all chains of standards.

The ISO/GPS Masterplan given in ISO 14638 gives an overview of the ISO/GPS system of which this document is a part. The fundamental rules of ISO/GPS given in ISO 8015 apply to this document and the default decision rules given in ISO 14253-1 apply to specifications made in accordance with this document, unless otherwise indicated. For more detailed information on the relationship of this International standard to other standards and to the GPS matrix model, see [Annex A](#).

In order to define the permissible interval for a geometrical characteristic, the designer only defines a condition (a unilateral tolerance limit or a bilateral pair of tolerance limits) for each workpiece, by considering the worst case impact in an assembly.

But when the tolerancing is based on a set of hypotheses about the population of the workpieces, one or more additional requirements should be added to verify these hypotheses.

NOTE The intent of this International Standard is not to define calculation methods to determine tolerances, but to give the means to express the hypotheses to verify.

Geometrical product specifications (GPS) — Population specification

1 Scope

This International Standard defines rules to establish and to indicate population specifications, which are used to specify conditions on population characteristics, which are established from a set of characteristic values obtained one on each workpiece of a population of workpieces.

A population specification (as applied to a population of workpieces considered as a collection and not as individual items) can be seen as a complementary requirement to the individual specification (as applied to each workpiece considered as individual items). Population specifications express the statistical hypotheses used on the population of workpieces.

NOTE 1 A population specification is a complement to an individual GPS specification.

NOTE 2 This International Standard is not intended to mandate a given tolerancing method or how to calculate tolerance values. Its intent is to specify tools to allow the expression of population specifications.

2 Normative references

The following documents, in whole or in part, are normatively referenced in this document and are indispensable for its application. For dated references, only the edition cited applies. For undated references, the latest edition of the referenced document (including any amendments) applies.

ISO 1101, *Geometrical product specifications (GPS) — Geometrical tolerancing — Tolerances of form, orientation, location and run-out*

ISO 14405-1, *Geometrical product specifications (GPS) — Dimensional tolerancing — Part 1: Linear sizes*

ISO 17450-1, *Geometrical product specifications (GPS) — General concepts — Part 1: Model for geometrical specification and verification*

3 Terms and definitions

For the purposes of this document, the terms and definitions given in ISO 17450-1 and the following apply.

3.1

population characteristic

statistic defined from the characteristic values, obtained on the population of workpieces or the population of assemblies

Note 1 to entry: Population characteristics are used to consider the population of workpieces.

Note 2 to entry: Population characteristics are only statistically meaningful when the values are based upon global individual characteristics, see Example 2.

EXAMPLE 1 The arithmetic mean and the standard deviation of a global individual characteristic on the population of workpieces, are population characteristics.

EXAMPLE 2 The minimum circumscribed diameter has one unique value for a given cylindrical feature. Therefore a population characteristic based on this individual characteristic value will be statistically meaningful. The two-point diameter for a given cylindrical feature will vary within a range, dependent upon the form deviations of the feature. In this case, one population characteristic for two-point diameter cannot be defined from the population of values. However, it is possible to establish a population characteristic from the maximum two point diameter along the geometric feature, which is a global individual characteristic, together with a population characteristic from the minimum two-point diameter along the geometric feature which is another global individual characteristic.

3.2 population condition

limit that applies to the population characteristic value

Note 1 to entry: Population conditions can be used for statistical process control (SPC).

EXAMPLE The mean value, μ , of the minimum circumscribed diameter of a population of workpieces can be considered as a population characteristic, and required to be less than or equal to 10,1, which is a population condition (see [Clause 6](#)).

3.3 statistic

completely specified function of random variables

[SOURCE: ISO 3534-1:2006, definition 1.8, modified — Notes have not been reproduced.]

Note 1 to entry: In GPS, the random variables, which are used are in most of cases one-dimensional (scalar). Multi-dimensional (vector) variables also exist.

Note 2 to entry: For a population or a sample of individual characteristic values, at least one statistic can be applied. In GPS, a statistic can be used on a population of local individual characteristic values taken on one workpiece or, on a population of global individual characteristic values taken on a population of workpieces.

EXAMPLE See [Table 1](#). More information can be found in ISO 3534- series.

Table 1 — Non exhaustive list of population statistics^a

	Description of the statistic	Mathematical description according to ISO 3534-1 ^b
A)	Minimum	minimum (X)
B)	Maximum	maximum (X)
C)	Mean: expected value	$\mu = E(X) = \frac{1}{n} \sum_{i=1}^n X_i ,$ or $\mu = E [g(X)] = \int g(X)dp = \int g(x)dF(x)$
D)	Mean deviation: difference between the mean and the target value (τ)	$\delta = \mu - \tau$
E)	Standard deviation	$\sigma = \sqrt{V(X)}$
F)	Variance	$V(X) = E \left\{ [X - E(X)]^2 \right\}$
G)	y % distribution quantile of the variable X	$X_{y \%} : P \left[X \leq X_{y \%} \right] = y \%$

Table 1 (continued)

	Description of the statistic	Mathematical description according to ISO 3534-1 ^b
H)	Median, i.e 50 % distribution quantile	$X_{50\%}$
I)	Median absolute deviation from median ^c	$\Delta_{50\%}$ with $\Delta = x - X_{50\%} $
a	The symbols used in this table are defined in Table 2	
b	Where X is the global characteristic value on one workpiece.	
c	See Reference [6] .	

4 Rules for establishing a population specification

4.1 General

A population characteristic is a characteristic, which is calculated from a set of values, each of which is an global individual characteristic value obtained on one workpiece of the population.

In some applications it is necessary to specify that one or more relations between the workpieces of the population shall be satisfied. The following rules describe the implication on the individual specification, and how to indicate a population specification.

A population characteristic can be used to manage statistical tolerancing requirements or the implementation of statistical process control indexes.

4.2 Rules

4.2.1 Rule 1: Description of a population specification

4.2.1.1 Rule # 1a (indicating a population specification)

By default, a GPS specification is an individual specification. When a population specification is required to complement an individual specification then the tolerance value of the individual GPS specification shall be followed by the modifier \diamond ST.

4.2.1.2 Rule # 1b (individual characteristic)

To define a population characteristic, an individual specification shall be used to define an individual signed global characteristic on each workpiece. In cases where the characteristic captures material deviation, the positive direction is out of the material.

4.2.1.3 Rule # 1c (deriving a global characteristic from a local characteristic)

By default, if the GPS characteristic is a local characteristic, it shall be transformed in one or two global characteristics by applying a rank order operator as defined in ISO 14405-1 ($\textcircled{\text{SA}}$, $\textcircled{\text{SX}}$, $\textcircled{\text{SN}}$, $\textcircled{\text{SR}}$, $\textcircled{\text{SD}}$, etc.). If no rank order operator is indicated, two separate global characteristics apply, one for the minimum and one for the maximum of the local characteristic.

ISO 18391:2016(E)

EXAMPLE 1 Defined transformation:

specification of local characteristic

$$10 \pm 0,1 \text{ (LP)}$$

specification of global characteristics

$$0,2 \text{ (LP) (SR)}$$

$$9,9 \text{ min. (LP) (SN)}$$

EXAMPLE 2 Implicit transformation:

specification of local characteristic

$$10 \pm 0,1 \text{ (LP)}$$

implicit global characteristics

$$+0,1 \text{ (LP) (SX)}$$

$$10 -0,1 \text{ (LP) (SN)}$$

4.2.1.4 Rule # 1d (population specification / individual specification)

By default a population specification is a complementary requirement to an individual specification. The individual specification and each population specification shall be satisfied independently. Conformance of the population of workpieces is subject to the conformance of all specified (individual and population) specifications.

When a population specification is not a complementary requirement to an individual specification then no individual specification shall be specified, but the individual characteristic, used to define the population characteristic, shall be specified explicitly.

For the purpose of general specifications, see ISO 2768-1, a dimension with a population specification is considered as having an individual tolerance indication. Therefore general specifications do not apply to this dimension.

The following examples illustrate the rule # 1d to show requirements combining or not combining individual specification and population specification.

	Indications of requirements	Individual specification	Population specification
a)	$\varnothing 8 \pm 0,1$	Yes	No
b)	$\varnothing 8 \pm 0,1 \text{ (ST) LP}_{pk} 1,33$	Yes	Yes
c)	$\varnothing 8 \text{ (SN) (ST) } \sigma 0,02$	No	Yes
d)	$\square 0,002$	Yes	No
e)	$\square 0,002 \text{ (ST) LP}_{pk} 1,33$	Yes	Yes
f)	$\square \text{ (F) (ST) } \sigma 0,02$	No	Yes

4.2.1.5 Rule # 1e (target value)

By default, the target value is equal to:

- the mid-value of the tolerance limits for a dimensional bilateral specification,
- zero for form, orientation, run-out, and location specifications;
- zero for surface texture parameters when the condition is defined only as an upper tolerance limit;

- the mid-value of the tolerance limits for a surface texture bilateral specification,

When no default target value is defined, the target value shall be defined.

NOTE The TEDs used in a geometrical specification of form, orientation, location or run-out are not target values; they allow the construction of reference feature from which the geometrical characteristic is established.

EXAMPLE Implicit target value defined for population specification from an individual characteristic with or without associated condition:

Individual characteristic	Target value for the population specification
$10 \pm 0,1$ (SA) (ST)	10
$0,1$ (SR) (ST)	0
(SR) (ST)	0
— $0,1$ (ST)	0
— (ST)	0

4.2.2 Rule 2: Description of type of individual GPS specification (univariate or multivariate)

4.2.2.1 Rule # 2a (default type of the individual GPS characteristic)

An individual global characteristic is by default a univariate characteristic unless it defines a population characteristic. Surface texture characteristics, dimensional characteristics, and form characteristics by default define univariate population characteristics and orientation and location characteristics by default define multivariate population characteristics.

NOTE The range of values of a population characteristic considered univariate is larger than the range of the statistical combination of the components of the same characteristic considered multivariate, especially for the characteristics of orientation or location. Of course, if the population characteristic is acceptable without taking into account rule # 2a, it will also be acceptable when taking into account rule # 2a.

4.2.2.2 Rule # 2b (multivariate individual GPS characteristic)

If an individual global characteristic shall be decomposed into a multivariate characteristic, this shall be explicitly indicated. In this case, the population characteristic is established from the population of

- global characteristics of the variation curves on each workpiece, or
- the collection of transformed characteristics resulting from the parameterization of the individual global characteristic on each workpiece.

EXAMPLE 1 The minimum circumscribed diameter is a univariate characteristic.

EXAMPLE 2 The location of the axis of a feature of size (as in the example of [Figure 1](#)) is by default a univariate global characteristic. It can be defined as a multivariate characteristic by considering the variation curve along the specified axis.

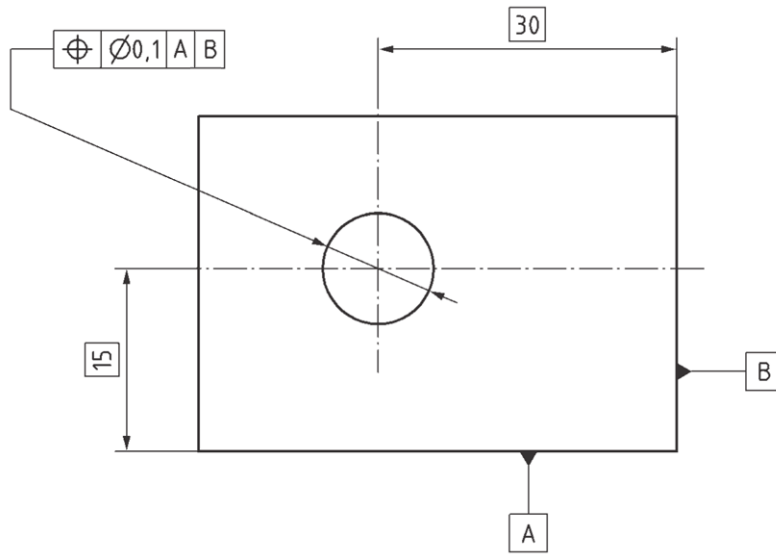
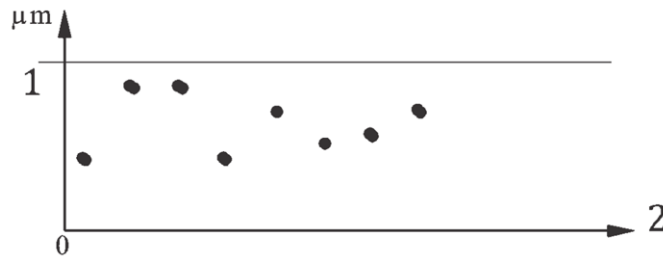

Figure 1 — Example of an individual specification of position

By default, the individual global characteristic of position is a univariate characteristic, defined as two times the maximum distance between the reference feature and the extracted feature (see [Figure 2](#)).

This individual global characteristic of position can also be decomposed into two characteristics as projection (in 2D view) on the axes X and Y (see [Figure 3](#)), built from the datum system A and B.



Key

- 1 position tolerance value
- 2 number of the result

Figure 2 — Example of a univariate characteristic defined on a set of individual results

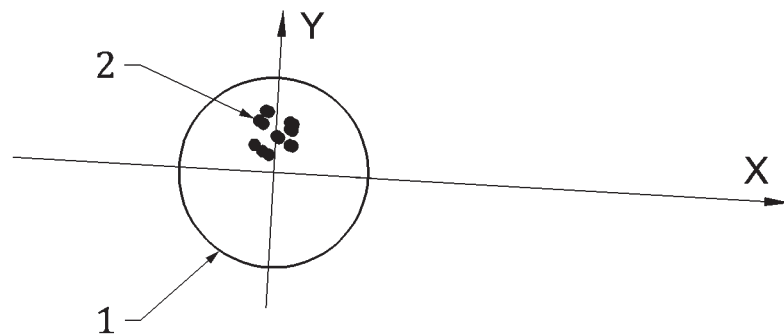

Key

- 1 tolerance zone
- 2 individual result in a section decomposed as coordinates X and Y in a cartesian system defined from the datum system A/B

Figure 3 — Example of a multivariate characteristic defined on a set of individual results in a section

EXAMPLE 3	Individual specification	Target value	Population specifications
	$\oplus \phi 0,1 A B$	0	$X \langle ST \rangle = 0,03$ $Y \langle ST \rangle = 0,03$

4.2.3 Rule 3

4.2.3.1 Rule # 3a (scale of multivariate characteristic)

When an individual characteristic is to be considered a multivariate characteristic, an appropriate system (Cartesian, polar, rules of the decomposition, etc.) used to define the multidimensional scale shall be indicated in the GPS specification.

NOTE 1 When an individual global characteristic is to be considered a multivariate characteristic, then the dimension of it can be reduced by parameterization.

NOTE 2 The tools for indicating the system used to define the multidimensional scale in the GPS specification have not been standardized.

4.2.3.2 Rule # 3b (system of parameterization)

When a parameterization system is indicated in the GPS specification, its parameters shall be described.

NOTE This system of parameterization can use a coordinate system.

EXAMPLE The result of the global individual characteristic on each workpiece, can be e.g.:

- a set of n-tuples giving the X,Y,Z coordinates of the local deviation.
- a p-tuples having as parameters the size deviation, the orientation deviation angles, the location deviation distances and the deviations of several form modes

5 Symbol used to specify a population specification

The terms and symbols used in this International shall be in accordance with [Table 2](#).

Table 2 — Terms and symbols

Term	Symbol	Definition
Upper tolerance limit of individual specification	U	Upper tolerance limit of individual specification
Lower tolerance limit of individual specification	L	Lower tolerance limit of individual specification
Target	τ	Target value
Mean	μ	Arithmetic mean of the population characteristic distribution
Mean deviation	δ	mean deviation from the target value $\delta = \mu - \tau$
y % distribution quantile of variable, X	$X_{y\%}$	y % distribution quantile of variable, X
Median	$X_{50\%}$	Median value of the population distribution
Standard deviation	σ	Standard deviation of the population characteristic distribution
Reference interval	$X_{99,865\%} - X_{0,135\%}$	Length of the reference interval (see ISO 3534-2)
Lower reference interval	$X_{50\%} - X_{0,135\%}$	Length of the lower reference interval (see ISO 3534-2)
upper reference interval	$X_{99,865\%} - X_{50\%}$	Length of the upper reference interval (see ISO 3534-2)
Spread	D	Variability span of the population characteristic distribution $D = 6\sigma$
Lower Centring ratio	F_{cl}	Ratio of the deviation of the mean from the target value and the range between the lower tolerance limit and the target value, $F_{cl} = (\mu - \tau)/(\tau - L)$
Upper centring ratio	F_{cu}	Ratio of the deviation of the mean from the target value and the range between the upper tolerance limit and the target value $F_{cu} = (\mu - \tau)/(U - \tau)$
	F_c	The larger of the absolute ratios of the deviation of the mean from the target value and the range between the upper or lower tolerance limit and the target value $F_c = \text{Max}[\text{abs}(F_{cl}; F_{cu})]$ for bilateral limit or $\text{abs}(F_{cl})$ or $\text{abs}(F_{cu})$ for respectively lower or upper unilateral limit
	Q_b	Ratio of the tolerance span and the standard deviation $Q_b = (U - L)/\sigma$
Inertia parameter	I	Square root of the sum of the squares of the mean deviation from the target value and the standard deviation $I = \sqrt{\delta^2 + \sigma^2}$
weighted inertia parameter	I_w	Square root of the sum of the squares of the weighted mean deviation from the target value and the standard deviation $I_w = \sqrt{w \cdot \delta^2 + \sigma^2}$

Table 2 (continued)

Term	Symbol	Definition
	F_L	Ratio of the deviation of the mean from the lower tolerance value and the spread divided by two $F_L = (\mu - L)/(D/2)$
	F_U	Ratio of the deviation of the mean from the upper tolerance value and the spread divided by two $F_U = (U - \mu)/(D/2)$
	F_k	Smaller ratio between F_L and F_U $F_k = \min(F_L; F_U)$ for bilateral tolerance or $F_k = F_L$ or F_U for respectively lower or upper unilateral limit
	F	Ratio of the tolerance interval value and the spread $(U - L)/D$ for bilateral tolerance only or $F = F_L$ or F_U for respectively lower or upper unilateral limit
process performance index	P_p^a	performance index (See ISO 3534-2) $P_p = \frac{U - L}{X_{99,865\%} - X_{0,135\%}}$
process performance index	P_{pk}^a	performance index (See ISO 3534-2) $P_{pk} = \min \left(\frac{U - X_{50\%}}{X_{99,865\%} - X_{50\%}}; \frac{X_{50\%} - L}{X_{50\%} - X_{0,135\%}} \right)$
	F_I	Ratio of the tolerance span and the inertia $F_I = \frac{(U - L)}{I}$
	F_{Iw}	Ratio of the tolerance span and the weighted inertia $F_{Iw} = \frac{(U - L)}{I_w}$
	Q_k	Ratio of the inertia parameter and the tolerance span in percent $Q_k (\%) = 100 \cdot \frac{I}{\tau}$
	Q	Minimum quality statistic (ISO 3534-2) $Q = \min(Q_U; Q_L)$
	Q_U	Upper quality statistic (ISO 3534-2) $Q_U = (U - \mu)/\sigma$
	Q_L	Lower quality statistic (ISO 3534-2) $Q_L = (\mu - L)/\sigma$
Probability conforming	$\% P$	Proportion of population inside a unilateral or bilateral interval (positive fitting)
Probability non-conforming	$\% N$	Proportion of population outside a unilateral or bilateral interval (negative fitting)
Probability non-conforming	P_t	Total nonconforming fraction (ISO 3534-2)

Table 2 (continued)

Term	Symbol	Definition
Probability non-conforming	P_U	Upper nonconforming fraction (ISO 3534-2)
Probability non-conforming	P_L	Lower nonconforming fraction (ISO 3534-2)
^a P_p and P_{pk} depending on the stability observed on the process and they may be replaced by C_p and C_{pk} , see ISO 22514-1		

NOTE The sampling introduces a statistical uncertainty on the estimated value of a population parameter (e.g. P_p, P_{pk}). This uncertainty is used for determining whether the population parameter belongs to a confidence interval based on the estimated value, the confidence level and of samples.

A population specification can be signed or not. Some population specification characteristics can be dependent on the condition given in the individual specification, but they can be also independent (see examples given in [Table 3](#)).

Table 3 — Examples of dependence or independence of population characteristics

Parameter	Type	Population specification	
		Independent of the individual specification condition	Dependent on the individual specification condition
Basic	Central tendency parameter	Mean μ	—
		Deviation of the mean from the target value $\delta = \mu - \tau$ (τ : target value)	$F_{cl} = \frac{\delta}{\tau - L}$
			$F_{cu} = \frac{\delta}{U - \tau}$
			$F_c = \max(F_{cu} ; F_{cl})$
	Dispersion parameter	Standard deviation (σ)	$Q_b = \frac{U - L}{\sigma}$
		Spread ($D = 6\sigma$)	$F = \frac{U - L}{6\sigma}$
		Reference interval $X_{99,865\%} - X_{0,135\%}$	$P_p = \frac{U - L}{X_{99,865\%} - X_{0,135\%}}$ ^a

Table 3 (continued)

Parameter	Type	Population specification	
		Independent of the individual specification condition	Dependent on the individual specification condition
Composite	(Combination between position and scale parameters)	Inertia parameter $I = \sqrt{\delta^2 + \sigma^2}$	$Q_k(\%) = 100 \cdot \frac{I}{\tau}$ $F_I = \frac{(U-L)}{I}$
		$I_w = \sqrt{w \cdot \delta^2 + \sigma^2}$	$F_{Iw} = \frac{(U-L)}{I_w}$
		—	$Q_U = \frac{U-\mu}{\sigma}$ $Q_L = \frac{\mu-L}{\sigma}$ $Q = \min(Q_U; Q_L)$
		—	$F_L = \frac{\mu-L}{D/2}$ $F_U = \frac{U-\mu}{D/2}$ $F_k = \min(F_U; F_L)$
			$P_{pk} = \min \left(\frac{U - X_{50\%}}{X_{99,865\%} - X_{50\%}}; \frac{X_{50\%} - L}{X_{50\%} - X_{0,135\%}} \right)$ a
Counting		—	% P
		—	% N

a P_p and P_{pk} depend on the stability observed on the process and may be replaced by C_p and C_{pk} , see ISO 22514-1

6 Rules for indicating a population specification

A population specification shall be indicated after an individual specification that it complements by using a population indicator. One or more population specifications shall be used to indicate these complementary requirement(s).

The population (specification) indicator is a hexagon with ST in it, that can be followed by an alphanumerical identifier. The length of the hexagon depends on the number of characters defining the identifier. The height of the hexagon is fixed.

This population indicator shall be numbered when it defines a generic population specification and more than one specific population specifications is given in the technical product documentation (TPD).

When only one generic population specification is given in the TPD, the identifier can be omitted. (See Examples 1 to 4).

NOTE For some geometrical specifications, the current GPS standards do not define the geometrical characteristic.

ISO 18391:2016(E)

EXAMPLE 1 $10 \pm 0,1$ (GG) (ST) (ST) = LP_{pk} 1,33

EXAMPLE 2 $+0,1$ (GN) (ST)
 $10 - 0,1$ (GX) (ST) (ST) = LF_l 1,33

EXAMPLE 3 \square 0,02 (ST) (ST) = LP_{pk} 1,33

EXAMPLE 4 $\langle 0, X, Y, Z \rangle$
 \equiv 0,02 B (ST) (ST) = LF_l 1,33

A population specification is directly or indirectly indicated after an individual specification or an individual characteristic indication.

When a population specification is directly indicated after an individual specification then the non-numbered population indicator is placed after the individual specification and follows the indication method defined in Form 1 below (without using of the symbol "="), see Example 5.

EXAMPLE 5 $\varnothing 10 \pm 0,1$ (GG) (ST) LP_{pk} 1,33

When a population specification is indirectly indicated, (see Example 6), defining a generic population specification, then the population indicator number is placed after the individual specification, and the population indicators shall be described near the title block, by one of the following methods:

a) Form 1: Indication of a population specification

- the population indicator followed by "=" when it indicates indirectly a generic population specification;
- the symbol L or U with a space when the population specification is a unilateral specification using L for a lower specification limit and U for an upper specification limit, respectively;

By default, if only one specification limit is defined, it is an upper specification limit and the U can be omitted.

- the symbol of the population characteristic followed by a space;
- its target value and a slash "/" followed by a space, if applicable e.g. to change the implicit target value;
- the value of the lower or upper limit or the signed values of the lower limit and the upper limit separated by a semicolon (";") or by "±" followed by the absolute value of specification limits (when they are symmetrical).

NOTE The sign of the value can be omitted when the sign is positive.

When the target value is not explicitly defined, the implicit target value is zero.

b) Form 2: Indication for a set of more than one population specification

- the population indicator followed by "="
- the set of population indicators separated by a semicolon (";")

Each population specification applies independently (see [Figure 4](#)).

EXAMPLE 6

$\varnothing 10 \pm 0,1$ (GG) (ST4)

\square 0,02 (ST1)

(ST1) = L Q4

(ST2) = I 0,005

(ST3) = μ 10/ -0,002; 0,005

(ST4) = (ST3) ; (ST2)

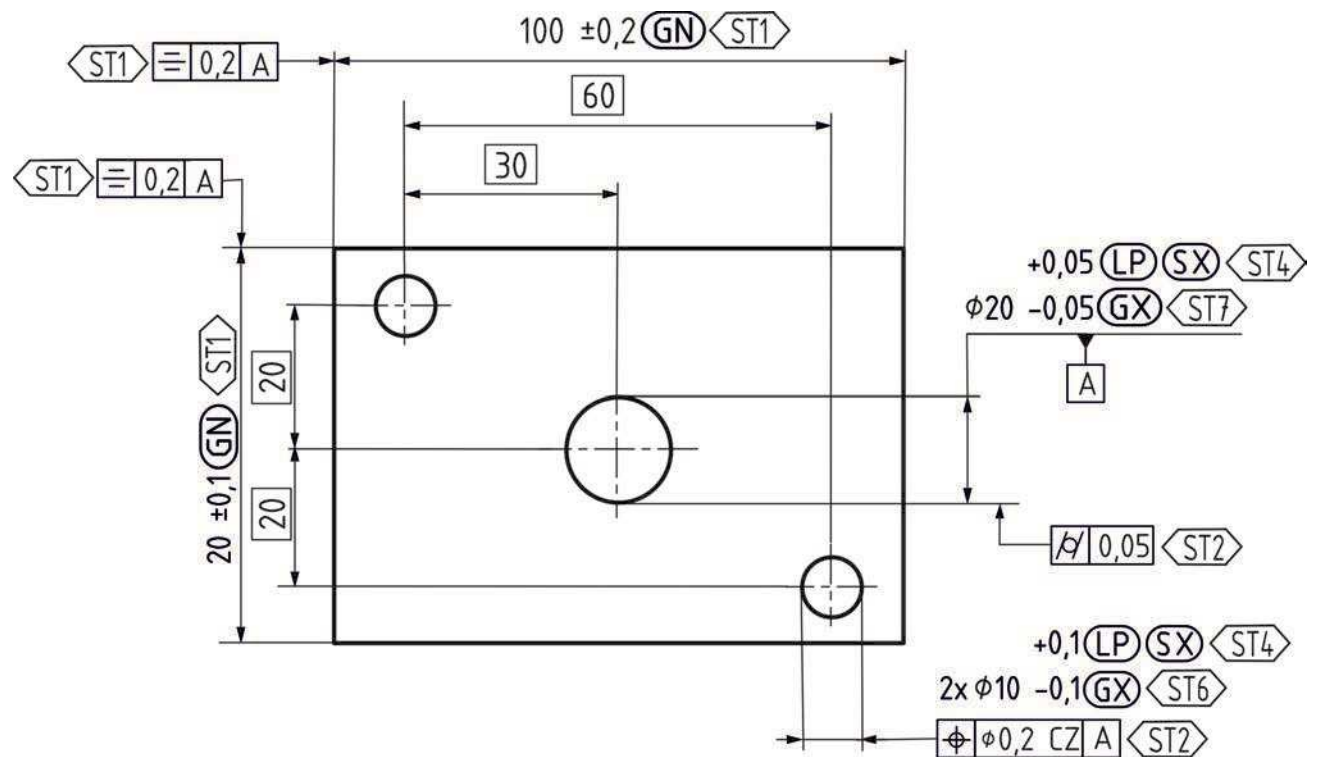

(ST1) = L P_p 1,66

(ST2) = I 0,003

(ST3) = L Q_U 8

(ST4) = L F_I 6

(ST5) = L Q_L 8

(ST6) = (ST1) ; (ST3)

(ST7) = (ST1) ; (ST5)

Figure 4 — Example of population specifications

Several kinds of flagnotes can be given in the TPD e.g. for moveable assemblies (see ISO/TS 17863), population specifications, or other complementary requirements.

For example, there can be a flagnote ST 1 and a flagnote 1: these two flagnotes have the same number but are not of same type.

Annex A (informative)

Relation in the GPS matrix model

A.1 General

For full details about the GPS matrix model see ISO 14638

A.2 Information about this standard and its use

This International standard covers a number of fundamental assumptions and principles that apply to all GPS standards and technical product documentation that is based on the GPS matrix system.

This International standard also covers the indication of non-default specification operators, either by direct indication or by the use of relevant documents or drawing specific defaults.

A.3 Position in the GPS matrix model

This International standard is a fundamental GPS standard, which influences any other standard in the GPS matrix system, as graphically illustrated in [Table A.1](#).

Table A.1 — Position in the GPS matrix model

	Chain links						
	A	B	C	D	E	F	G
	Symbols and indications	Feature requirements	Feature properties	Conformance and non-conformance	Measurement	Measurement equipment	Calibration
Size	•	•	•	•	•	•	•
Distance	•	•	•	•	•	•	•
Form	•	•	•	•	•	•	•
Orientation	•	•	•	•	•	•	•
Location	•	•	•	•	•	•	•
Run-out	•	•	•	•	•	•	•
Profile surface texture	•	•	•	•	•	•	•
Areal surface texture	•	•	•	•	•	•	•
S u r f a c e imperfections	•	•	•	•	•	•	•

Bibliography

- [1] ISO 3534 (all parts), *Statistics — Vocabulary and symbols*
- [2] ISO 8015, *Geometrical product specifications (GPS) — Fundamentals — Concepts, principles and rules*
- [3] ISO 14253-1, *Geometrical product specifications (GPS) — Inspection by measurement of workpieces and measuring equipment — Part 1: Decision rules for proving conformity or nonconformity with specifications*
- [4] ISO 14638, *Geometrical product specifications (GPS) — Matrix model*
- [5] ISO/TS 17863, *Geometrical product specifications (GPS) — Tolerancing of moveable assemblies*
- [6] ISO 22514-1, *Statistical methods in process management — Capability and performance — Part 1: General principles and concepts*
- [7] WILCOX R.R. 2001), *Fundamentals of Modern Statistical Methods: Substantially improving Power and Accuracy*, Springer- Verlag New York. Inc., ISBN 0-387-95157-1

