

---

---

## General requirements for solid wood flooring

*Exigences générales pour revêtements de sol en bois massif*



Reference number  
ISO 17959:2014(E)

© ISO 2014



**COPYRIGHT PROTECTED DOCUMENT**

© ISO 2014

All rights reserved. Unless otherwise specified, no part of this publication may be reproduced or utilized otherwise in any form or by any means, electronic or mechanical, including photocopying, or posting on the internet or an intranet, without prior written permission. Permission can be requested from either ISO at the address below or ISO's member body in the country of the requester.

ISO copyright office  
Case postale 56 • CH-1211 Geneva 20  
Tel. + 41 22 749 01 11  
Fax + 41 22 749 09 47  
E-mail [copyright@iso.org](mailto:copyright@iso.org)  
Web [www.iso.org](http://www.iso.org)

Published in Switzerland

.....

# Contents

	Page
<b>Foreword</b> .....	<b>iv</b>
<b>1 Scope</b> .....	<b>1</b>
<b>2 Normative references</b> .....	<b>1</b>
<b>3 Terms and definitions</b> .....	<b>1</b>
<b>4 Requirements</b> .....	<b>4</b>
4.1 Moisture content .....	4
4.2 Geometrical characteristics .....	4
4.3 Paint film performance .....	5
4.4 Grading .....	5
4.5 Other declarations at the time of the first delivery .....	6
<b>5 Test methods</b> .....	<b>6</b>
5.1 Geometrical characteristics .....	6
5.2 Test of moisture content and paint film performance .....	6
<b>6 Packaging</b> .....	<b>7</b>
<b>7 Marking</b> .....	<b>7</b>
<b>Annex A (normative) Test methods of measuring geometrical characteristics</b> .....	<b>9</b>

## Foreword

ISO (the International Organization for Standardization) is a worldwide federation of national standards bodies (ISO member bodies). The work of preparing International Standards is normally carried out through ISO technical committees. Each member body interested in a subject for which a technical committee has been established has the right to be represented on that committee. International organizations, governmental and non-governmental, in liaison with ISO, also take part in the work. ISO collaborates closely with the International Electrotechnical Commission (IEC) on all matters of electrotechnical standardization.

The procedures used to develop this document and those intended for its further maintenance are described in the ISO/IEC Directives, Part 1. In particular, the different approval criteria needed for the different types of ISO documents should be noted. This document was drafted in accordance with the editorial rules of the ISO/IEC Directives, Part 2 (see [www.iso.org/directives](http://www.iso.org/directives)).

Attention is drawn to the possibility that some of the elements of this document may be the subject of patent rights. ISO shall not be held responsible for identifying any or all such patent rights. Details of any patent rights identified during the development of the document will be in the Introduction and/or on the ISO list of patent declarations received (see [www.iso.org/patents](http://www.iso.org/patents)).

Any trade name used in this document is information given for the convenience of users and does not constitute an endorsement.

For an explanation on the meaning of ISO specific terms and expressions related to conformity assessment, as well as information about ISO's adherence to the WTO principles in the Technical Barriers to Trade (TBT), see the following URL: [Foreword — Supplementary information](#).

The committee responsible for this document is ISO/TC 218, *Timber*.

# General requirements for solid wood flooring

## 1 Scope

This International Standard specifies the requirements and test methods of characteristics of solid wood flooring boards for internal (interior) use as flooring. It also specifies packaging and marking requirements.

It is applicable to both finished and unfinished solid wood flooring board. Solid wood parquet is not covered.

## 2 Normative references

The following documents, in whole or in part, are normatively referenced in this document and are indispensable for its application. For dated references, only the edition cited applies. For undated references, the latest edition of the referenced document (including any amendments) applies.

ISO 2409, *Paints and varnishes — Cross-cut test*

ISO 3130:1975, *Wood — Determination of moisture content for physical and mechanical tests*

ISO 15184, *Paints and varnishes — Determination of film hardness by pencil test*

ISO 24294, *Timber — Round and sawn timber — Vocabulary*

ISO 16415, *Non-structural timber grading requirements*

## 3 Terms and definitions

For the purposes of this document, the terms and definitions given in ISO 24294 and the following apply.

### 3.1

#### **solid wood flooring**

assembly of individual solid wood boards installed either on the primary structure or on the sub-floor

### 3.2

#### **solid wood flooring board**

long solid (single-layer) wood piece with parallel sides prepared to a regular thickness and constant profile(s) with or without profiled edges and/or ends, capable of being assembled with other analogous wood pieces

Note 1 to entry: See [Figure 1](#).

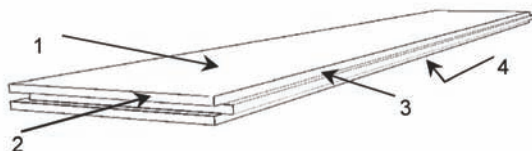

a) With profiled edges and/or ends

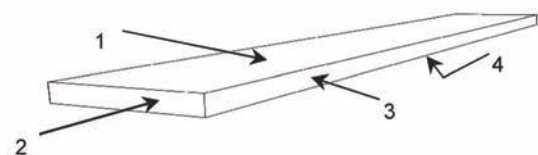

b) Without profiled edges and/or ends

#### **Key**

- 1 face
- 2 end

- 3 edge
- 4 back

**Figure 1 — Example of solid wood flooring board**

**3.3 finished solid wood flooring board**

flooring board that has been surface-coated with lacquer, wax, oil, etc.

**3.4 unfinished solid wood flooring board**

flooring board without any surface coating

**3.5 lipping mismatch**

difference in height between two adjacent faces of assembled flooring boards when laid on a flat surface

Note 1 to entry: See [Figure 2](#)

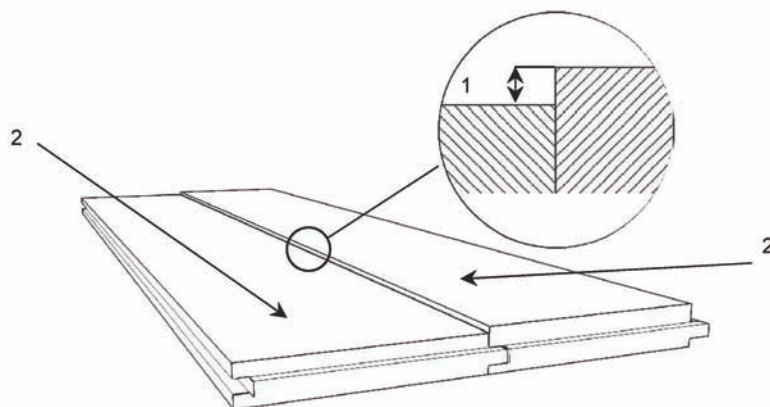

- Key**
- 1 lipping
  - 2 face

**Figure 2 — Example of lipping**

**3.6 bow**

lengthwise curvature of a flooring board perpendicular to the face

Note 1 to entry: See [Figure 3](#).

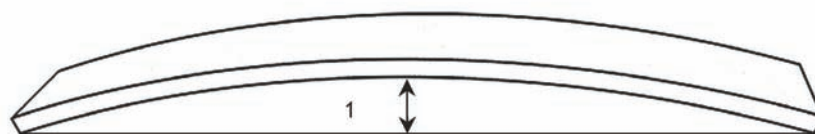

- Key**
- 1 bow

**Figure 3 — Example of bow**

**3.7**

**cup**

curvature of a flooring board across the width of the face

Note 1 to entry: See [Figure 4](#).

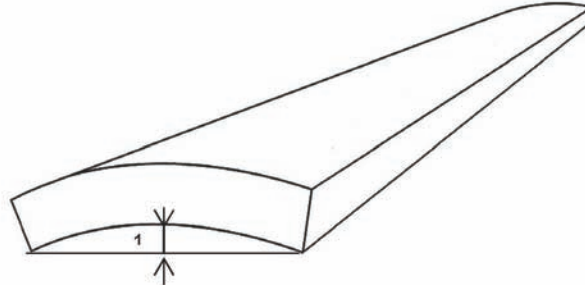

**Key**

1 cup

**Figure 4 — Example of cup**

**3.8**

**spring**

lengthwise curvature of a flooring board perpendicular to the edge

Note 1 to entry: See [Figure 5](#).

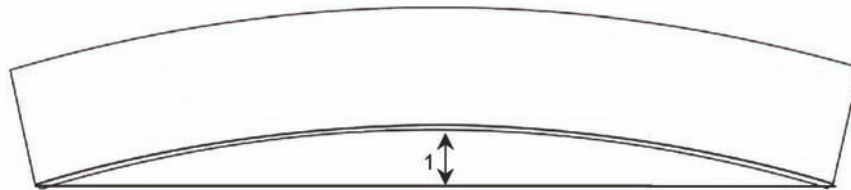

**Key**

1 spring

**Figure 5 — Example of spring**

**3.9**

**twist**

distortion of a solid wood flooring board in which one corner is out of the plane of the other three corners

Note 1 to entry: See [Figure 6](#).



**Key**

1 twist

**Figure 6 — Example of twist**

## 4 Requirements

### 4.1 Moisture content

Unless otherwise agreed on the order between buyer and supplier, individual solid wood flooring board shall have moisture content before the shipment of the first delivery between 6 % and the average equilibrium moisture content of the wood found in the customer's local climate.

NOTE For instance, the moisture content in France is between 7 % and 11 %.

### 4.2 Geometrical characteristics

#### 4.2.1 General

Unless otherwise agreed on the order between buyer and supplier, all dimensions of solid wood flooring board shall be given at a reference moisture content of 9 %. Unless there is evidence to the contrary, it shall be assumed that the thickness and width of a piece of timber increase by 0,25 % for every 1 % of moisture content above the reference moisture content, and decrease by 0,25 % for every 1 % of moisture content below the reference moisture content.

#### 4.2.2 Dimensions and tolerance

##### 4.2.2.1 Dimensions

The common dimensions are given in [Table 1](#).

**Table 1 — Dimensions for solid wood flooring board**

Dimensions in millimetres

Thickness	Width	Length
≥10	≥90	≥ 400

NOTE The length and width of the solid wood flooring board refer to face size of the solid wood flooring board.

##### 4.2.2.2 Tolerances

Unless otherwise agreed on the order between buyer and supplier, solid wood flooring board shall have the tolerances of dimensions at the time of the first delivery given in [Table 2](#).

**Table 2 — Tolerances**

Dimensions in millimetres

Dimension	Tolerance
Length	±2,0
Width	±1,0
Thickness	±1,0
Lipping (mismatch)	≤0,5

#### 4.2.3 Deformation

##### 4.2.3.1 General

Unless otherwise agreed on the order between buyer and supplier, the deformation limitations shall meet the requirements in [4.2.3.2](#) to [4.2.3.5](#).



#### 4.2.3.2 Cup

The cup shall not exceed 0,7 % of the width at the time of the first delivery.

#### 4.2.3.3 Bow

The bow shall be evaluated taking into account the length and the method of laying.

If the flooring boards are to be installed by gluing only, this shall be stated when ordering. For such flooring boards, the bow shall not exceed 0,5 % of the length at the time of the first delivery.

If the flooring boards are to be installed by nailing, the limit for the bow shall be determined by their suitability to be laid using commercially available equipment.

#### 4.2.3.4 Spring

The spring shall be evaluated taking into account the length.

For lengths not exceeding 1 m, the spring shall not exceed 0,1 % of the considered length at the time of the first delivery.

For lengths more than 1 m, the spring shall not exceed 0,2 % of the considered length at the time of the first delivery.

#### 4.2.3.5 Twist

The twist shall be evaluated taking into account the length and the method of laying.

If the flooring boards are to be installed by gluing only, this shall be stated when ordering. For such flooring boards, the twist shall not exceed 0,15 % of the length at the time of the first delivery.

If the flooring boards are to be installed by nailing, the limit for the twist shall be determined by its suitability to be laid using commercially available equipment.

#### 4.2.4 Squareness and other angular deviations

The deviation from all the 90° angles and from required angles for specific patterns shall not exceed 0,2 % measured across the width.

### 4.3 Paint film performance

**4.3.1** This subclause is only applicable to finished solid wood flooring board coated with paint sand; it is not applicable to finished solid wood flooring board coated with oil, wax and unfinished solid wood flooring board.

**4.3.2** The performance requirements of the paint film shall comply with [Table 3](#).

**Table 3 — Performance requirements of paint film**

Performance	Requirements
Adhesion (class)	≤3
Hardness	≥H

### 4.4 Grading

The grading requirements of solid wood flooring boards shall comply with ISO 16415.

#### 4.5 Other declarations at the time of the first delivery

Where applicable (e.g. if required by local standards or regulations), the following can be declared accordingly: reaction to fire, formaldehyde release, content of pentachlorophenol, breaking strength, slip resistance, thermal properties, biological durability, volatile organic compounds (VOC) release, etc.

### 5 Test methods

#### 5.1 Geometrical characteristics

The geometrical characteristics shall be measured with measuring instruments capable of recording to the specified degree of accuracy.

The length and width of the solid wood flooring board shall be measured on the face.

Geometrical characteristics shall be determined in accordance with the methodology set out in [Annex A](#).

NOTE Alternative test methods that guarantee a similar accuracy may also be used.

#### 5.2 Test of moisture content and paint film performance

##### 5.2.1 Specimen preparation and dimension requirement

The position, dimension and number of test specimens are specified in [Figure 7](#) and [Table 4](#).

If the length of one solid wood flooring board is not sufficient to allow cutting of all the required test specimens, these can be made on other randomly selected flooring boards till all qualified test specimens are cut.

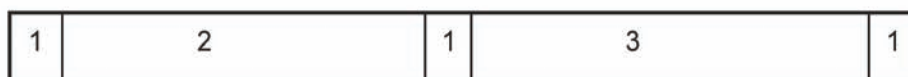

#### Key

- 1 moisture content
- 2 adhesion of paint film
- 3 hardness of paint film

**Figure 7 — Performance tests of solid wood flooring board — Position of test samples**

**Table 4 — Performance tests of solid wood flooring board — Dimension and number of test samples**

Test	Dimension of test samples (length × width) mm × mm	Number of test samples	Position in <a href="#">Figure 7</a>
Moisture content	20,0 × flooring board width	9	1
Adhesion of paint film	250,0 × flooring board width	1	2
Hardness of paint film	300,0 × flooring board width	1	3

##### 5.2.2 Moisture content

The average moisture content of the three positions (see [Figure 7](#)) stands for the moisture content of the solid wood flooring board.

The moisture content shall be measured with an electric moisture meter. The moisture meter, of any design, shall be calibrated for the species of wood concerned, and capable of making an individual measurement with an error of not more than  $\pm 2\%$  at moisture contents from 7% to 28%.

In case of dispute, the moisture content shall be determined by the oven drying method according to ISO 3130:1975.

The surface paint film shall be removed for measuring the moisture content.

### 5.2.3 Performance of paint film

#### 5.2.3.1 Test of paint film adhesion

The position, dimension and number of test samples shall comply with [Figure 7](#) and [Table 4](#).

Three test areas are selected on the face of the test sample. Two of them shall be selected near two ends, and one at the centre, as shown in [Figure 8](#).

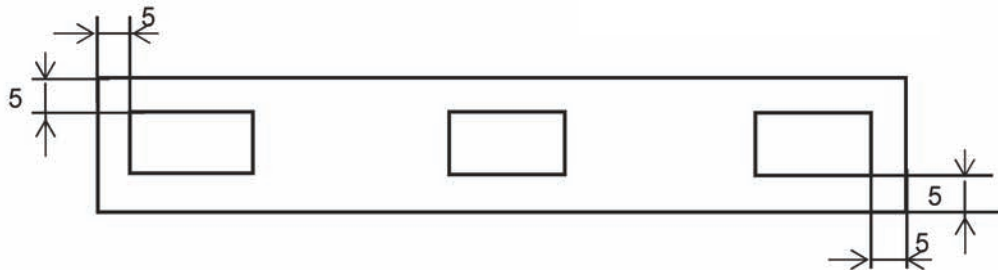

Figure 8 — Test areas for the paint film adhesion test

The paint film adhesion shall be determined as specified in ISO 2409.

#### 5.2.3.2 Test of paint film hardness

The position, dimension and number of test samples shall comply with [Figure 7](#) and [Table 4](#).

Paint film hardness shall be measured according to ISO 15184.

## 6 Packaging

By agreement between buyer and supplier, the products shall be packed according to the production type, specification and grade, individually. The package shall be moisture resistant.

## 7 Marking

By agreement between buyer and supplier, the package shall be clearly marked with the following information as a minimum:

- name of manufacturer or supplier;
- trade name;
- a reference to this International Standard ;
- dimensions;
- wood species;
- date of production and/or batch number;

— quantity of products and/or covered surface

## Annex A (normative)

### Test methods of measuring geometrical characteristics

#### A.1 Instrument and apparatus

##### A.1.1 General

The equipment specified in this standard is given as an indication. Any other equipment providing the same results with at least the same accuracy may be used.

##### A.1.2 Equipment to measure the dimensions

**A.1.2.1 Calliper**, with an accuracy of 0,05 mm and a useful measuring length corresponding to the width of the flooring boards to be measured.

**A.1.2.2 Micrometre**, with a limit deviation of 0,05 mm and two parallel flat circular feelers having a diameter of  $(10 \pm 1)$  mm.

**A.1.2.3 Graduated ruler**, used when the dimensions to be measured are out of the calliper's range, with a limit deviation of 0,5 mm for a length of up to 2 m, and of 1 mm for longer lengths.

**A.1.2.4 Feeler gauge**, readable to the nearest 0,05 mm.

**A.1.2.5 Straight ruler**, at least as long as the actual flooring board, with a gauge readable to the nearest 0,5 mm regarding the bow and 0,1 mm regarding the spring.

**A.1.2.6 Calibration plate**, consisting of a reference plate of suitable material to calibrate to zero the gauge fitted on the apparatus.

**A.1.2.7 Reference square**, with its longer arm consistent with the length of the flooring boards to be checked and not less than 210 mm.

Each arm shall have a fixed feeler at about 10 mm from the corner.

The longer arm shall have a second feeler, adjustable between 200 mm and 300 mm from the fixed feeler.

The shorter arm shall have a gauge, readable to the nearest  $\pm 0,01$  mm, adjustable to the width of the flooring board to be controlled.

**A.1.2.8 Calibration ruler square**, to set the gauge to 0.

## A.2 Test methods

### A.2.1 Conditioning

Measure the flooring board in its delivered size at the reference moisture content given in the product standards or, if there is no product standard, at a given reference moisture content. If specified, condition the flooring board to constant mass prior to measurement.

NOTE Constant mass is considered to be reached when the results of two successive weighing operations carried out at an interval of 24 h, do not differ by more than 0,1 % of the mass of the flooring board.

### A.2.2 Test procedure

#### A.2.2.1 General

Proceed as follows with the method of measurement and record the results every time. Mark all position of measurements on the flooring board. When there is a doubt about a measurement or the value is outside the limits, proceed immediately as follows: carry out two other measurements at 5 mm on each side of the point where the first measurement was just taken. Average the three measurements.

#### A.2.2.2 Dimensions of solid wood flooring boards

##### A.2.2.2.1 Length and width of the flooring board

###### For rectangular or square flooring boards:

With the calliper or, if it is out of its range, with an equipment, measure the length and width along two lines parallel to the arises as they are seen when the flooring board is assembled. The lines of measurement shall be within 5 mm to 10 mm from the edges. If the span between the edges exceeds 500 mm, one measurement shall be made, in addition, along a central line.

Mark all positions of measurements on the flooring board.

###### For other flooring boards:

Make the measurements with one of the items of equipment defined in [A.1.2](#).

Mark all positions of measurements on the flooring board.

Measure the length along the long edges between two adjacent angles (two measurements).

Measure the width perpendicularly to the edges.

##### A.2.2.2.2 Thickness of the flooring board

Measure the thickness of the flooring board with the calliper or with the micrometre. If the flooring board is not longer than 500 mm, make two measurements each 5 mm to 10 mm from each end along the longitudinal lines of measurement.

##### A.2.2.2.3 Squareness

Adjust the adjustable feeler and the gauge of the reference square defined in [A.1.2](#) to the lengths of the sides of the flooring board they shall be applied on. In case of long flooring board (more than 500 mm), the distance between the adjustable and fixed feeler shall be 300 mm.

Then set the gauge to zero using the calibration square.

Apply the reference square to one of the four angles with full contact on the three feelers and the gauge. The gauge located within 10 mm to 20 mm from the apparent end of the flooring board gives the deviation from the calibration square.

Repeat the procedure with the opposite angle on the same diagonal with the exception of tongued and grooved flooring boards where the measurement is carried out above the tongue.

#### A.2.2.2.4 Lipping

Join two flooring boards together and place the resulting assembly on a flat surface. Measure the difference in levels of the faces of the two flooring boards with the feeler.

#### A.2.2.2.5 Deformation

##### Bow

Determine the bow by measuring, at the middle of the length of the flooring board, the distance separating the face of the flooring board from the straight reference line joining the end top arises of the flooring board, as shown in [Figure 3](#).

Place the flooring board with its concave surface (the face for a flooring board with concave bow, the back for an flooring board with convex bow), in contact, at its two ends, with the ruler or with the reference plate. Measure the maximum gap between the actual surface and the ruler or the reference plate — generally around the centre of the flooring board, either

- with a feeler gauge, or
- with a calliper, or
- with any device providing the same accuracy.

Record a convex bow as a (+) value.

Record a concave bow as a (-) value.

NOTE If the maximum bow is not in the middle of the length, the measurement can be carried out at the appropriate place and this should be mentioned in the report.

##### Cup

Determine the cup by measuring, at the middle of the width of the flooring board, the distance separating the face of the flooring board from the straight reference line joining the top arises of the edges of the flooring board, as shown in [Figure 4](#).

Place the flooring board with its concave surface, in contact, at the four corners, with the ruler or with the reference plate. Measure the maximum gap between the actual surface and the ruler or the reference plate — generally around the centre of the flooring board, either

- with feeler gauge, or
- with a calliper, or
- with any device providing the same accuracy.

Record a convex cup as a (+) value.

Record a concave cup as a (-) value.

##### Spring

Determine the spring by measuring, at the middle of the length of the flooring board, along the lengthwise edges of the flooring board, the distance separating one edge from the straight reference line joining the two arises of that edge, as shown in [Figure 5](#).

NOTE The measurement is usually carried out on the edge bearing the groove.

Measure the spring on the groove side.

Measure the maximum gap between the laid edge and the ruler or the reference plate — generally around the centre of the flooring board, either

- with feeler gauge, or
- with a calliper, or
- with any device providing the same accuracy.

### A.3 Test results and expression of results

#### A.3.1 Expression of results of dimensions

$$L = \frac{L_1 + L_2 + L_n}{n}$$

where

$L$  is the length of the solid wood flooring board with an accuracy of  $\pm 0,1$  mm;

$n$  is the number of measurements.

$$W = \frac{W_1 + W_2 + W_n}{n}$$

where

$W$  is the width of the solid wood flooring board with an accuracy of  $\pm 0,1$  mm;

$n$  is the number of measurements.

$$T = \frac{T_1 + T_2 + T_n}{n}$$

where

$T$  is the thickness of the solid wood flooring board (mm);

$n$  is the number of measurements.

Note the minimum and the maximum values.

Average the four or six measurements to the nearest 0,1 mm.

#### A.3.2 Expression of results of squareness

Divide each value given by the gauge by the distance expressed in millimetres between the fixed feeler and the gauge and multiply by 100.

It gives the relative deviation expressed in %.

#### A.3.3 Expression of results of warp

##### Cup

Average the measurements to the nearest 0,05 mm.

##### Bow



Report the measurements to the nearest 0,5 mm for 1 m and to the nearest 1 mm for floorings longer than 1 m.

**Spring**

Report the measurements to the nearest 0,1 mm.

