

INTERNATIONAL
STANDARD

ISO
17916

First edition
2016-03-15

Safety of thermal cutting machines

Sécurité des machines de coupage thermique



Reference number
ISO 17916:2016(E)

© ISO 2016



COPYRIGHT PROTECTED DOCUMENT

© ISO 2016, Published in Switzerland

All rights reserved. Unless otherwise specified, no part of this publication may be reproduced or utilized otherwise in any form or by any means, electronic or mechanical, including photocopying, or posting on the internet or an intranet, without prior written permission. Permission can be requested from either ISO at the address below or ISO's member body in the country of the requester.

ISO copyright office
Ch. de Blandonnet 8 • CP 401
CH-1214 Vernier, Geneva, Switzerland
Tel. +41 22 749 01 11
Fax +41 22 749 09 47
copyright@iso.org
www.iso.org

Contents

	Page
Foreword	iv
Introduction	v
1 Scope	1
2 Normative references	1
3 Terms and definitions	2
4 Significant hazards	4
5 Safety requirements and protective measures	4
5.1 General	4
5.2 List of safety requirements	5
6 Information for use	15
6.1 General	15
6.2 Instruction handbook	15
6.3 Noise declaration	16
6.4 Marking	16
Annex A (informative) Examples of hazards, hazardous situations, and hazardous events	17
Annex B (informative) Calculation examples for dimensioning of exhaust systems	21
Annex C (informative) Example for the lower limit of protective devices	24
Annex D (informative) Example for calculation of the compression corresponding to the acceptable maximum force in case of collision between the machine and a human body ..	25
Annex E (normative) Measurement of the air velocity at the entrance plane of the cutting table ..	27
Bibliography	28

Foreword

ISO (the International Organization for Standardization) is a worldwide federation of national standards bodies (ISO member bodies). The work of preparing International Standards is normally carried out through ISO technical committees. Each member body interested in a subject for which a technical committee has been established has the right to be represented on that committee. International organizations, governmental and non-governmental, in liaison with ISO, also take part in the work. ISO collaborates closely with the International Electrotechnical Commission (IEC) on all matters of electrotechnical standardization.

The procedures used to develop this document and those intended for its further maintenance are described in the ISO/IEC Directives, Part 1. In particular the different approval criteria needed for the different types of ISO documents should be noted. This document was drafted in accordance with the editorial rules of the ISO/IEC Directives, Part 2 (see www.iso.org/directives).

Attention is drawn to the possibility that some of the elements of this document may be the subject of patent rights. ISO shall not be held responsible for identifying any or all such patent rights. Details of any patent rights identified during the development of the document will be in the Introduction and/or on the ISO list of patent declarations received (see www.iso.org/patents).

Any trade name used in this document is information given for the convenience of users and does not constitute an endorsement.

For an explanation on the meaning of ISO specific terms and expressions related to conformity assessment, as well as information about ISO's adherence to the WTO principles in the Technical Barriers to Trade (TBT) see the following URL: [Foreword - Supplementary information](#)

The committee responsible for this document is ISO/TC 44, *Welding and allied processes*, Subcommittee SC 9, *Health and safety*.

Requests for official interpretations of any aspect of this International Standard should be directed to the Secretariat of ISO/TC 44/SC 9 via your national standards body. A complete listing of these bodies can be found at www.iso.org.

Introduction

This International Standard has been created in recognition of the particular hazards that are presented by thermal cutting machines.

This International Standard is a type-C standard as outlined in ISO 12100.

When provisions of a type-C standard are different from those which are stated in type-A or type-B standards, the provisions of the type-C standard will take precedence over the provisions of the other standards for machines that have been designed and built in accordance with the provisions of the type-C standard.

The machinery concerned and the extent to which hazards, hazardous situations, and events are covered are indicated in the Scope of this International Standard.

Hazards associated with thermal cutting machines are well recognized, but the sources of the hazards are frequently unique to a particular thermal cutting system. The number and type(s) of hazard(s) is (are) directly related to the nature of the thermal cutting process and the complexity of the installation. The risks associated with these hazards vary with the type of equipment used, its purpose, and the way in which it is installed, programmed, operated, and maintained.

This International Standard is not applicable to thermal cutting machines that were manufactured prior to its publication date.

Safety of thermal cutting machines

1 Scope

This International Standard specifies the safety requirements and measures for machinery covering design, construction, production, transport, installation, operation, maintenance, and putting out of service.

This International Standard applies to machinery using thermal cutting and or marking processes such as oxy-fuel, plasma arc. This International Standard applies to machinery the basis of which is either designed as open gantry, cantilever machine, or the track of which is incorporated in the cutting table.

This International Standard does not cover design standards for specific tools, e.g. oxy-fuel hose standards, electrical requirements for plasma power supplies. Most tools used on thermal cutting machines have specific design standards.

This International Standard does not cover handheld cutting equipment and cutting equipment which is combined with a constrained tracking system mounted on the work piece.

Risks arising from thermal cutting tools may be covered by related standards.

Risks arising from laser radiation, except those caused by position indicating lasers, are not covered by this International Standard. Those risks are covered by ISO 11553.

Machines that combine thermal processes with other processes (e.g. grinding, drilling, milling, etc.) are only partly covered. Risks arising from these other processes may be covered by related standards.

2 Normative references

The following documents, in whole or in part, are normatively referenced in this document and are indispensable for its application. For dated references, only the edition cited applies. For undated references, the latest edition of the referenced document (including any amendments) applies.

ISO 3746, *Acoustics — Determination of sound power levels and sound energy levels of noise sources using sound pressure — Survey method using an enveloping measurement surface over a reflecting plane*

ISO 3821, *Gas welding equipment — Rubber hoses for welding, cutting and allied processes*

ISO 4871, *Acoustics — Declaration and verification of noise emission values of machinery and equipment*

ISO 5171, *Gas welding equipment — Pressure gauges used in welding, cutting and allied processes*

ISO 5172, *Gas welding equipment — Blowpipes for gas welding, heating and cutting — Specifications and tests*

ISO 5175, *Equipment used in gas welding, cutting and allied processes — Safety devices for fuel gases and oxygen or compressed air — General specifications, requirements and tests*

ISO 7289, *Gas welding equipment — Quick-action couplings with shut-off valves for welding, cutting and allied processes*

ISO 7291, *Gas welding equipment — Pressure regulators for manifold systems used in welding, cutting and allied processes up to 30 MPa (300 bar)*

ISO 8207, *Gas welding equipment — Specification for hose assemblies for equipment for welding, cutting and allied processes*

ISO 17916:2016(E)

ISO 11202, *Acoustics — Noise emitted by machinery and equipment — Determination of emission sound pressure levels at a work station and at other specified positions applying approximate environmental corrections*

ISO 12100:2010, *Safety of machinery — General principles for design — Risk assessment and risk reduction*

ISO 13849-1, *Safety of machinery — Safety-related parts of control systems — Part 1: General principles for design*

ISO 13854, *Safety of machinery - Minimum gaps to avoid crushing of parts of the human body*

ISO 13855, *Safety of machinery — Positioning of safeguards with respect to the approach speeds of parts of the human body*

ISO 13857, *Safety of machinery — Safety distances to prevent hazard zones being reached by upper and lower limbs*

ISO 15012-4¹⁾, *Health and safety in welding and allied processes — Equipment for capture and separation of welding fume — Part 4: General requirements for welding fume separation equipment*

ISO/TR 28821, *Gas welding equipment — Hose connections for equipment for welding, cutting and allied processes — Listing of connections which are either standardised or in common use*

EN 894-1, *Safety of machinery — Ergonomics requirements for the design of displays and control actuators — General principles for human interactions with displays and control actuators*

EN 894-3, *Safety of machinery — Ergonomics requirements for the design of displays and control actuators — Control actuators*

IEC 60204-1:2005, *Safety of machinery — Electrical equipment of machines — Part 1: General requirements*

IEC 60974-1, *Arc welding equipment — Part 1: Welding power sources*

3 Terms and definitions

For the purposes of this document, the following terms and definitions apply.

3.1 thermal cutting
cutting process that uses heat of different sources to melt or oxidize the material and a high speed jet to remove the liquid material

3.2 tool
any component to carry out a working process

Note 1 to entry: Working processes are, for example, cutting or marking.

3.3 aggregate
unit that carries one or more *tools* (3.2) and which is used to position the tools relatively to each other and/or to adjust the bevel angle of the tool(s)

3.4 cutting table
support for the work piece to be cut

3.4.1 dry cutting table
cutting table (3.4) not filled with water

1) To be published.

3.4.2**water table**

cutting table (3.4) filled with water

Note 1 to entry: The work piece may be placed under, on, or above the water.

3.5**exhaust unit**

unit to exhaust fumes and exhaust gases generated by the cutting process

3.6**exhaust system**

system including *cutting table* (3.4), ducting, and *exhaust unit* (3.5)

3.7**marking process**

method for applying markings on the surface of the work piece

3.8**movement envelope**

area which can be reached by a moveable part of the machine

3.9**oxy-fuel cutting**

thermal cutting (3.1) process using an oxygen/fuel gas flame to heat up the material to its ignition temperature and an oxygen jet to oxidize and remove the material

3.10**plasma cutting**

thermal cutting (3.1) process using a constricted arc to heat up the material and a high velocity jet of ionized gas to remove the molten material

3.11**positioning laser**

laser pointer to indicate the exact position of the machine

3.12**section****segment**

partition of the *cutting table* (3.4)

Note 1 to entry: Sections are used to make exhausting more efficient. Flaps in each section allow the exhaust system to open the suction only to the currently active cutting area.

3.13**time weighted average****TWA**

quantitative average which is determined from the measurement of a sample, which has been taken over a known time interval, multiplied by the desired time interval expression, and divided by the total time of over which the sample was obtained

Note 1 to entry: For occupational exposure, a working shift of eight hours is commonly used as the averaging time. Values are typically expressed as a concentration of a contaminant in air, or decibels, in the case of noise exposure.

3.14**working area**

area where operation of cutting/marketing *tool* (3.2) is intended by design and/or manufacturer's specifications

3.15

overall stopping distance

distance travelled within the time interval between the actuation of the sensing function and the termination of the hazardous machine function

3.16

machine environment

sphere of influence of the machine

4 Significant hazards

The listed hazards (see [Table A.1](#)) assume foreseeable access from all directions, as well as unexpected start-up. Risks to both the operators and other persons who can have access to the danger zones are identified, taking into account hazards that can occur under various conditions (e.g. commissioning, set-up, production, maintenance, repair, decommissioning) during the life of the machine. The assessment includes an analysis of the effect of failure in the control system. Following the intended use of the machine which includes maintenance, setting and cleaning, the reasonably foreseeable misuse, the identification of the significant hazards associated with the machine, and risks shall be evaluated.

For identification and evaluation of hazards, ISO 12100 applies.

5 Safety requirements and protective measures

5.1 General

Machines covered by this International Standard shall meet the safety requirements listed hereafter.

With regard to hazards not covered by this International Standard, these machines shall be designed in compliance with the principles given in ISO 12100.

Machines, covered by this International Standard, shall be equipped with protective devices shown in the [Table 1](#), column 2.

Machines requiring access to the movement envelope during operation require protective devices against collision with the gantry in the movement envelope. Protective devices against collision with the gantry in the movement envelope may not be required in all situations, e.g. for machines having construction-related short operating cycles, or a cutting table which is not suited for access due to its design.

5.2 List of safety requirements

Table 1 — List of safety requirements and/or protective measures and their verification procedures for cutting machines using thermal cutting processes

Hazard	Safety requirements and/or protective measures	Verification
<p>1 Mechanical</p>	<p>1.1 Risk of collision between the operator and the machine while the operator is on the ground</p> <p>1.1.1 Collision when the operator is unimpeded by obstacles</p> <p>The lower limit of the protective devices shall start at ≤ 180 mm above the table. Otherwise, due to the variable thickness of work pieces, the lower limit of protective devices used may be set to 50 mm or less plus the maximum thickness of the work piece specified in the machine documentation, measured from the table. This applies to specified material thicknesses >130 mm.</p> <p>NOTE An example is given in Annex C.</p> <p>1.1.1.1 General</p> <p>The following conditions shall be fulfilled in case of collision with the body:</p> <ul style="list-style-type: none"> — force, $F < 150$ N; — energy, $E < 10$ J; — pressure, $p < 50$ N/cm². <p>1.1.1.2 Relative speed of the machine to the operator ≤ 15 m/min</p> <p>The conditions described in 1.1.1.1 are met with a use of a bumper that is able to compress at least 4 mm (e.g. working clothes wrapping the body plus human tissues) and the collision area >3 cm².</p> <p>NOTE An example for a calculation is given in Annex D.</p> <p>1.1.1.3 Relative speed of the machine to the operator >15 m/min</p> <p>The conditions described in 1.1.1.1 shall be met using one or more of the measures below:</p> <ul style="list-style-type: none"> a) bumpers to safely remove the operator out of the danger zone fulfilling the conditions of 1.1.1.1; b) bumper according to ISO 13856-3 which activates an emergency stop according to ISO 13850. The stroke shall be greater than the overall stopping distance. This bumper shall function without exceeding the conditions described in 1.1.1.1. The required performance level is C according to ISO 13849-1; c) emergency trip wire according to ISO 13856-3 which activates an emergency stop according to ISO 13850. The maximum prolongation of the trip wire shall allow for the overall stopping distance, D, without adding additional hazards to persons or other obstacles, see Figures 1 and 2. This emergency trip wire shall function without exceeding the conditions described in ISO 13856-3 and 1.1.1.1. The required performance level is C according to ISO 13849-1. 	<p>Visual inspection, calculation and measurement</p>

Table 1 (continued)

Hazard	Safety requirements and/or protective measures	Verification
	<div style="text-align: center;">  </div> <p>Key</p> <p>s_{max} maximum stroke (maximum travel of the machine to trigger the emergency stop function)</p> <p>s_{min} minimum stroke (minimum travel of the machine to trigger the emergency stop function)</p> <p>A, B emergency trip wire</p> <p>a Focal points of an ellipse.</p> <p style="text-align: center;">Figure 1 — Emergency trip wire</p> <div style="display: flex; justify-content: space-around; align-items: flex-end;"> <div style="text-align: center;">  <p>a) Contact</p> </div> <div style="text-align: center;">  <p>b) Triggered</p> </div> <div style="text-align: center;">  <p>c) Stop</p> </div> </div> <p>Key</p> <p>1 person/obstacle (not moving)</p> <p>D overall stopping distance</p> <p>s_d stopping distance</p> <p>s_{max} maximum stroke (maximum travel of the machine to trigger the emergency stop function)</p> <p style="text-align: center;">Figure 2 — Emergency trip wire function</p>	<p>Visual inspection, calculation and measurement</p>

Table 1 (continued)

Hazard	Safety requirements and/or protective measures	Verification
	<p>d) Electro Sensitive Protective Equipment (ESPE) using Active Opto-Electronic Protective Devices (AOPD) which activates an emergency stop according to ISO 13850. The distance between the ESPE using AOPD and the hazard shall be greater than the overall stopping distance. The required performance level is C according to ISO 13849-1.</p> <p>ESPE using AOPD shall be positioned in accordance with ISO 13855 and designed in accordance with IEC 61496-2.</p> <p>NOTE Special care shall be taken on the methodology as given in ISO 13855, where it is possible to define variant ESPE using AOPD in type C standards.</p> <p>1.1.2 Collision when the operator is impeded by obstacles</p> <p>The lower limit of the protective devices shall start at ≤ 180 mm above the table. Otherwise, due to the variable thickness of work pieces, the lower limit of protective devices used may be set to 50 mm or less plus the maximum thickness of the work piece specified in the machine documentation, measured from the table. This applies to specified material thicknesses >130 mm.</p> <p>NOTE An example is given in Annex C.</p> <p>The conditions described in 1.1.1.1 shall be met using one or more of the measures below:</p> <p>a) ESPE using AOPD which activates an emergency stop according to ISO 13850. The distance between the ESPE using AOPD and the hazard shall be greater than the overall stopping distance. The required performance level is <i>D</i> according to ISO 13849-1.</p> <p>b) bumper which activates an emergency stop according to ISO 13850. The stroke shall be greater than the overall stopping distance. This bumper shall function without exceeding the conditions described in 1.1.1.1. The required performance level is <i>D</i> according to ISO 13849-1.</p> <p>In the case where a foreign object is present in the rail mounting fasteners of a machine (e.g. a foot is trapped), the gantry shall have a safety device installed to detect its presence and activate an emergency stop according to ISO 13850. This safety device shall function without exceeding the conditions described in 1.1.1.1. The required performance level is <i>D</i> according to ISO 13849-1.</p> <p>ESPE using AOPD shall be positioned in accordance with ISO 13855:2010, 5.2, with the parameter <i>K</i> to be equal to the maximum positioning speed of the machine's fastest axis and parameter C set to 0 mm.</p> <p>NOTE The parameter <i>K</i>, being equal to the maximum positioning speed of the machine's fastest axis, is due to the fact that people themselves are not moving towards the gantry.</p>	<p>Visual inspection, calculation and measurement</p>

Table 1 (continued)

Hazard	Safety requirements and/or protective measures	Verification
	<p>1.2 Risk while stepping/standing on the cutting table</p> <p>To avoid falling while stepping on the table, e.g. for marking and picking up parts, an adequate ascent support shall be available.</p> <p>To avoid injuries while walking on the table, safe walking areas shall be (temporarily) installable, e.g. plates.</p> <p>This does not apply to tables which are not able to carry a person. In this case, signs on the machine and the safety instructions in the manual shall point out not to step on the table.</p> <p>Additional requirements for while the machine is in operation</p> <p>The conditions described in 1.1.1.1 shall be met using some of the measures below:</p> <ul style="list-style-type: none"> — bumper which activates an emergency stop according to ISO 13850. The stroke shall be greater than the overall stopping distance. This bumper shall function without exceeding the conditions described in 1.1.1.1. The required performance level is <i>D</i> according to ISO 13849-1. — ESPE using AOPD which activates an emergency stop according to ISO 13850. The distance between the ESPE using AOPD and the hazard shall be greater than the overall stopping distance. The required performance level is <i>D</i> according to ISO 13849-1. 	<p>Visual inspection</p>
	<p>1.3 Outside the machine</p> <p>Protections against unauthorized persons are required.</p> <p>NOTE There could be specific national regulations in force dealing with this topic.</p> <p>The safety area to the outer machine movement envelope shall be installed according to ISO 13854 and ISO 13857.</p> <p>This safety area shall be defined in the manufacturer's instructions.</p> <p>For safety devices outside the machine, the required performance level is <i>D</i> according to ISO 13849-1.</p> <p>EXAMPLE Possible safety devices are ESPE using AOPD, active bumpers, trip wires, fences, safety (shut-off) mats, etc.</p> <p>To allow the operator sufficient access to the machine in normal operation, a clearance of 500 mm from the machine movement envelope shall be kept free of obstructions. Due to the fact that the hazards are easily recognizable, a presence detection system for this clearance area is not required.</p> <p>If the safety area as designed by the manufacturer cannot be realized around the movement envelope due to site specific restraints, then the requirements specified in 1.1 shall be met.</p>	<p>Measurement Visual inspection</p>

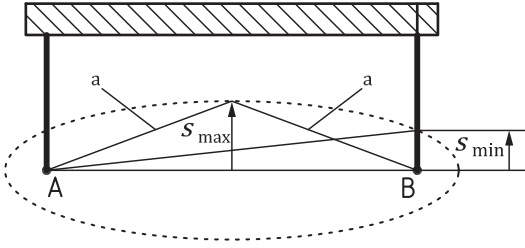
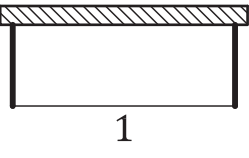
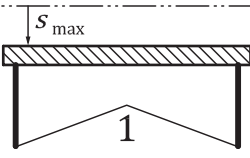
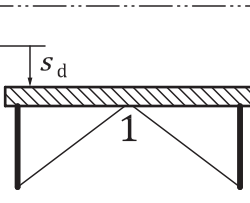
Table 1 (continued)

Hazard	Safety requirements and/or protective measures	Verification
	<p>1.4 Suspension of safety functions</p> <p>1.4.1 General</p> <p>Movements of the machine/aggregates are only allowed as long as the protective devices, according to 1.1, are in position or activated.</p> <p>If for reasons of maintenance, service, or setting protective devices are disabled, machine movements are allowed as given in 1.4.2 and 1.4.3. Disabling of the protective devices shall only be possible by using a lockable selector.</p> <p>1.4.2 Speeds up to 6 m/min</p> <p>Speeds ≤ 6 m/min during service, maintenance, or setting are permitted in connection with at least one of the following devices:</p> <ul style="list-style-type: none"> — a hold to run control device in accordance with IEC 60204-1:2005, 9.2.4; — an electronic hand wheel. <p>Rotating aggregates (e.g. rotating bevel units) should be limited to a circumferential speed of 6 m/min.</p> <p>The required performance level is C according to ISO 13849-1.</p> <p>1.4.3 Speeds above 6 m/min</p> <p>Higher speeds during service, maintenance, or setting are permitted only in connection with a hold to run control device in accordance with IEC 60204-1:2005, 9.2.4 and an enabling control device in accordance with IEC 60204:2005, 9.2.6.3.</p> <p>The required performance level is D according to ISO 13849-1.</p>	Measurement Functional test
	<p>1.5 End stops</p> <p>In all directions of movement, end stops shall be provided to safely stop the machine movement. If mechanical end stops are used, these end stops shall be designed in a way that crushing between the end stop and other components of the machine is avoided.</p> <p>The inevitable resulting crushing points should be covered. If this is not possible because the function of the machine would be impeded (e.g. at transversal end stops), they shall at least be clearly marked.</p>	Visual inspection
	<p>1.6 Falling objects — Push out of work pieces</p> <p>Collision of the tool(s) with tilted parts may cause wedging or pushing out work pieces. Appropriate measures shall be provided to avoid such critical situations (e.g. by predetermined breaking points, force limitation of the tool carrier, or collision protection units).</p>	Visual inspection

Table 1 (continued)

Hazard	Safety requirements and/or protective measures	Verification
2 Electrical	<p>2.1 Direct and indirect contact</p> <p>The entire electrical equipment of a machine shall be designed according to IEC 60204-1.</p>	Visual inspection
	<p>2.2 Plasma cutting hazards</p> <p>The entire electrical equipment of a plasma machine shall be designed according to IEC 60204-1 and IEC 60974-1.</p> <p>Warning signs close to each of the plasma torches shall indicate that it is mandatory to switch off the plasma power source before any activities at the torch.</p>	Visual inspection
	<p>2.3 Protection against electric shock on the Work Piece</p> <p>Appropriate measures to ensure sufficient grounding of the work piece shall be provided with the machine. If a sufficient grounding cannot be ensured automatically, additional devices (e.g. clamps) shall be used.</p> <p>NOTE The No Load or Open Circuit Voltage of plasma cutting machines can exceed 400 volts and are lethal in contact with the human body. Safety measures can be found in the instruction manual of the plasma cutting power source (according to IEC 60974-1).</p>	Visual inspection
	<p>2.4 Ignition unit for oxy-fuel cutting</p> <p>Temporary high frequency/high voltage is present for these units. The risks associated with them shall be pointed out in the operator's manual.</p>	Visual inspection
3 Thermal hazards	<p>3.1 Contact with the hot work piece</p> <p>To avoid burns by the hot work piece, personal protective equipment shall be worn. Signs on the machine and safety instructions in the manual shall point to the obligation to wear personal protective equipment.</p>	Visual inspection
	<p>3.2 Contact with the hot tool</p> <p>If hot tools cannot be covered, personal protective equipment shall be worn. Signs on the machine and safety instructions in the manual shall point to the obligation to wear personal protective equipment.</p>	Visual inspection
	<p>3.3 Contact with hot slag and sparks</p> <p>Slag splashes and sparks are inevitable due to the process. Where possible, technical measures shall ensure that at a distance of 2 m and greater from the machine, slag splashes, and sparks are avoided. Persons that stay within the splashing zone around the machine shall wear suitable personal protective equipment. Signs on the machine and safety instructions in the manual shall point to the obligation to wear personal protective equipment.</p>	Visual inspection
	<p>3.4 Contact with the gas flame or the plasma arc</p> <p>The same measures that protect from mechanical hazards, work piece/aggregates as required under 1.1 shall also protect from contact with the gas flame or arc. The suspension of safety functions given in 1.4 shall assure that the machine movement is safely stopped and its start is only possible using a hold to run control device.</p> <p>The operating mode for maintenance/service shall only be possible to be enabled by the use of a lockable selector switch.</p> <p>NOTE There will be additional risks present, e.g. gas flame or plasma arc. Only well-experienced and trained personnel shall carry out those activities, using proper PPE and information shall be given in the manual.</p>	Function control by visual inspection

Table 1 (continued)

Hazard	Safety requirements and/or protective measures	Verification
4 Noise hazards	4.1 Risk of hearing damage or hearing loss due to noise caused by the cutting process As long as the noise level caused by the cutting operation cannot sufficiently be reduced by means of process control, measures for noise reduction close to the source of noise or acoustic housing of the (entire) machine shall be evaluated (see ISO 15667 and ISO/TR 11688-1). If, for technical reasons, the noise cannot be reduced to an acceptable level, the technical information delivered with the machine shall point out this particular residual risk. Signs on the machine and safety instructions in the manual shall point to the obligation to wear personal protective equipment if the noise level of the machine is greater than 80 dB(A).	Verification of given noise level
	4.2 Disturbing acoustic communication Due to the fact that thermal cutting processes cause heavy noise, acoustic warning signals maybe covered up by this noise. This shall be pointed out in the safety instructions of the user manual.	Visual inspection
	4.3 Design of Status Indicators Acoustic indicators for certain operating or fault conditions of cutting machines can easily be ignored due to high noise exposure in the machine environment and hence not fulfil their task. Such status indicators shall therefore be visual indicators.	Visual inspection
5 Vibration	Not relevant	
6 Radiation hazards	6.1 Risk of eye damages, loss of sight, or skin burns/cancer caused by high emission of light (IR visible and UV) from the cutting process As long as the level of light radiation cannot be sufficiently reduced by means of process control, measures for reduction near the radiation source or shadowing/housing of the machine shall be checked (e.g. in accordance with EN 12198). If for technical reasons a sufficient reduction is impossible (e.g. when the operator visually monitors the process), person(s) staying close to the machine shall wear eye protection (e.g. EN 175) and appropriate clothing in accordance with ISO 11611. Signs on the machine and safety instructions in the manual shall point out the obligation to wear personal protective equipment.	Visual inspection
	6.2 Risk of eye damages or loss of sight caused by laser light If positioning lasers are used, laser class 2 lasers with a maximum power of 1 mW shall be selected for the application. Any laser shall be mounted so that it is impossible to directly look into the laser. For cutting lasers, see ISO 11553.	Visual inspection

Table 1 (continued)

Hazard	Safety requirements and/or protective measures	Verification
<p>7 Material/substance hazards</p>	<p>7.1 Health hazards caused by cutting/welding gases or fumes</p> <p>7.1.1 General</p> <p>Gases and fumes that are generated by the processes are hazardous. Considerations shall be made for operator safety. A suitable method is capturing the gases and fumes at the source. This is to ensure at the site of operation of the machine, the applicable maximum concentrations of hazardous substances at the workplace are not exceeded. In some cases, an additional room ventilation system may be necessary to ensure TWA (time weighted average) compliance in accordance to local occupational health and safety regulations.</p> <p>The efficiency of the exhaust unit shall be monitored in accordance with ISO 15012-4. If insufficient performance of the exhaust unit is detected, the start of a new cutting process shall be prevented.</p> <p>The design of the equipment for capture and separation of fume shall be in accordance with ISO 15012-4. Additional risks (e.g. fire) are dealt with in ISO 15012-4.</p>	<p>Visual inspection</p>
	<p>7.1.2 Dry cutting table</p> <p>A sufficient extraction is considered being obtained, if the table and the exhaust system are designed in such a way that the capture velocity at cutting level/exhausted airflow per m² active surface of the cutting table for oxy-fuel, cutting is not less than the following:</p> <ul style="list-style-type: none"> — 1,0 m/s or about 3 600 (m³/h)/m² for material thickness up to 100 mm; — 1,2 m/s or about 4 300 (m³/h)/m² for material thickness up to 200 mm; — 1,4 m/s or about 5 000 (m³/h)/m² for material thickness up to 300 mm; <p>and for plasma, cutting not less than the following:</p> <ul style="list-style-type: none"> — 1,0 m/s or about 3 600 (m³/h)/m² for cutting-amperage up to 150 A; — 1,15 m/s or about 4 100 (m³/h)/m² for cutting-amperage up to 300 A; — 1,3 m/s or about 4 700 (m³/h)/m² for cutting-amperage up to 450 A; — 1,4 m/s or about 5 000 (m³/h)/m² for cutting-amperage greater than 450 A. <p>NOTE A calculation example is given in Annex B.</p> <p>If the cutting table is divided into sections and the overlap to the adjoining section is less than 10% (see Figure B.1), there is no requirement to consider this in airflow calculations. If the overlap to the adjoining section is greater than 10 %, e.g. bevel cutting (see Figure B.2), or when using two or more torches which are not in a line (see Figure B.3), this is required to be considered into airflow calculations.</p> <p>For cutting of non-flat work pieces, e.g. curved tank or boiler ends or profiles, special extraction devices may be necessary to achieve comparable results.</p>	<p>Check of the calculation of the flow rate</p> <p>Measuring of air velocity according to Annex E.</p>

Table 1 (continued)

Hazard	Safety requirements and/or protective measures	Verification
	<p>7.1.3 Water table</p> <p>During the use of water filled tables, the majority of hazardous particles are captured in the water. This depends on how the cut is carried out: under, on, or above the water level. Cutting under at least 40 mm water is considered to be safe without using a ventilation system.</p> <p>NOTE For requirements regarding gas extraction, see 7.1.1.</p> <p>Cutting under other conditions, especially above the water, causes fumes and gases which may require additional operator protection, e.g. an exhaust system [see 6.2 n) below this table].</p> <p>Aluminium cutting on a water filled table may cause the generation of hydrogen. If hydrogen is trapped under the metal being cut or the supporting devices, there is a potential risk of explosion. Appropriate measures shall be taken to avoid the accumulation of hydrogen. The user's manual shall indicate proper measures/precautions to avoid accumulation.</p>	Visual inspection
	<p>7.2 Health hazard caused by cooling liquid for the plasma system</p> <p>Cooling liquids shall only be used if a safety data sheet is available. When handling the liquid, the safety measures prescribed in the safety data sheet shall be observed. The machine shall be designed such that the required safety measures can be performed easily.</p>	Visual inspection
	<p>7.3 Hazards caused by (combustible) gases under pressure</p> <p>All gas conducting components shall meet the requirements resulting from the environment of the cutting process and be suitable for the gases used according to ISO/TR 28821, ISO 3821, ISO 5171, ISO 5172, ISO 5175, ISO 7289, ISO 7291 and ISO 8207. Some other important standards for gas conducting components are given in the Bibliography.</p>	Visual inspection

Table 1 (continued)

Hazard	Safety requirements and/or protective measures	Verification
8 Hazards generated by neglecting ergonomic principles in the design process	8.1 Unhealthy postures or excessive effort (repetitive strain) Machines shall be designed in accordance with ergonomic principles so as to avoid excessive effort, unhealthy posture, or fatigue during use and in particular — work pieces, tooling, and accessories shall be easily moved. Lifting equipment can be required for parts over 10 kg in weight (see also EN 1005-2:2003+A1:2008, Table 1).	Visual inspection
	8.2 Inadequate consideration of human anatomy The positioning, labelling, and illumination of control devices and points for observation or service shall be chosen to satisfy ergonomic principles (see EN 614-1, EN 614-2, EN 894-1, EN 894-2, EN 894-3, EN 1005-1, EN 1005-2, EN 1005-3, and EN 999).	Measurement, check that distances involved in normal operation are in accordance with the referenced standards.
	8.3 Inadequate local lighting Lighting at the control panel shall be a minimum of 500 lux as measured at the control panel. This requirement shall be pointed out in the manual. If workers for any reason have to walk on the cutting table, a suitable lighting shall be provided. Designated lighting all over the cutting table normally is not practicable, therefore the workshop lighting should provide a minimum of 200 lux. This shall be pointed out in the manual.	Visual inspection
	8.4 Human errors, human behaviour Equipment and accessories indicated in the instruction handbook and not readily available for adjusting and maintaining the machine shall be provided.	Visual inspection
	8.5 Inadequate design, location or identification of manual controls Input devices (e.g. key boards, key pads, and push buttons) shall be in accordance with EN 894-1 and EN 894-3.	Visual inspection
	8.6 Inadequate design or location of visual display units Screen displayed information shall be clear and unambiguous. Reflections and glare shall be minimized (see EN 894-1 and EN 894-2).	Visual inspection and measurement
	8.7 Errors of fitting Means shall be embodied in the design of machine parts to prevent errors of fitting (e.g. use of male/female connections, asymmetrical location features) and/or the machine parts shall be marked with instructions for fitting.	Practical checks

Table 1 (continued)

Hazard	Safety requirements and/or protective measures	Verification
9 Hazards associated with the environment in which the machine is used	<p>9.1 Slip, trip, trap, and fall of persons</p> <p>Places of work and means of access on machines (stairs, integral ladders, platforms, and walkways) shall be designed to minimize the likelihood of slips, trips, trap, and falls by the provision of hand holds, foot holds, and where necessary, slip resistant surfaces. Warnings about hazards and precautions shall be given in the information for use.</p>	By observation and, where necessary, measurement during normal operation.
	<p>9.2 High parts of the machine which must be accessible for maintenance or trouble shooting</p> <p>Where frequent access is required (i.e. at least once per shift), means of access shall be provided (see group A for examples). If only occasional access is required, one or both of the examples in B shall be provided.</p> <p>Group A:</p> <ul style="list-style-type: none"> — permanent means of access (e.g. stairways, ladders see ISO 14122-1) — fixed working platforms with fixed railings and toe boards against falling hazards (see ISO 14122-2). <p>Group B:</p> <ul style="list-style-type: none"> — supports for safety belt; — means to attach movable ladders. 	Visual inspection

6 Information for use

6.1 General

Machine warning devices (e.g. visual signals), markings (e.g. signs, symbols), and instructional material (e.g. manuals for operation, maintenance) shall be in accordance with ISO 12100.

6.2 Instruction handbook

In addition to the requirements of [6.1](#), each machine shall be accompanied by an instruction handbook containing the following:

- a) the name and address of the manufacturer/supplier;
- b) any necessary information for safe installation of the machine and its guarding system (e.g. floor conditions, services, anti-vibration mountings, guarding fitting);
- c) instructions for how the initial test and examination of the machine and its guarding system are to be carried out before first use and being placed into production;
- d) instructions for periodic maintenance, test and examination of the machine, guards, protective devices, and other safety critical parts;
- e) instructions for any test or examination necessary after change of component parts or addition of optional equipment (both hardware and software) to the machine which can affect the safety functions;
- f) instructions for safe operation, setting, and maintenance including safe working practices and the training necessary to achieve the required skill level of operators;
- g) the intended application of the machine;
- h) instructions on control systems including circuit diagrams for electrical, hydraulic, and pneumatic systems;

ISO 17916:2016(E)

- i) the noise levels determined by methods specified in [6.3](#);
- j) descriptions of possible failure modes and advice on detection and prevention by periodic maintenance and correction;
- k) the specification for any fluid to be used in lubrication, braking, transmission, or cooling system;
- l) guidance on correct selection, preparation, application, and maintenance of lubricants and coolants;
- m) provide guidance on the means for the release of persons trapped in the machine;
- n) information describing residual risks [e.g. conditions where noise levels are likely to exceed 80 dB (A), hazards arising from sharp or hot tools/components, emission of hazardous fumes or gases];
- o) recommendations on additional protective measures (e.g. personal protective equipment);
- p) information defining the limits for the maximum mass, moment of inertia, tilting moment, and spatial envelope of tools for machines supplied with automatic tool magazine systems;
- q) information defining the limits for the spatial envelope, maximum mass and position of the centre of gravity of the workpiece;
- r) procedures to avoid errors of refitting during maintenance of the machine.

A check list should be provided for the points d), e), and f) and include drawings and diagrams.

6.3 Noise declaration

Noise measurement shall be made according to ISO 3746 or ISO 11202 as appropriate.

The declaration shall be made concerning the airborne noise emission. The declaration and verification of noise emission values shall be according to ISO 4871, using the dual-number form of declaration.

Information on noise emission should also be provided in the sales literature.

6.4 Marking

Each machine shall be marked in a distinct and permanent manner in accordance to ISO 12100:2010, 6.4.4 and IEC 60204-1:2005, 16.4.

For example:

- machine type;
- the designation of machinery and the designation of series or type;
- name and address of the manufacturer/provider;
- mass of machine;
- supply data for electrical and where applicable;
- hydraulic and pneumatic systems (e.g. minimum pneumatic pressure);
- lifting points for transportation and installation purposes where applicable;
- speed range where applicable;
- signs for the use of personal protective equipment;
- any other information needed for fitting shall be provided.

Annex A (informative)

Examples of hazards, hazardous situations, and hazardous events

Table A.1 — List of significant hazards and major sources of these hazards associated with cutting machines

No.*)	Description	Example(s) of related hazardous situation(s)	Associated activity	Related danger zone	5.2, Table 1 reference
1	Mechanical hazards				
1.1	Crushing	moving axes	setting, maintenance, loading/unloading	movement envelope – between moving and fixed elements of the machine	1.1, 1.2, 1.3
		moving axes	monitoring	machine environment - between moving elements of the machine and fixed elements in the machine environment	1.1, 1.2, 1.3
1.2	Shearing	moving axes	setting, maintenance, loading/unloading	movement envelope - between moving and fixed elements of the machine	1.1, 1.2, 1.3
		moving axes	monitoring	machine environment - between moving elements of the machine and fixed elements in the machine environment	1.1, 1.2, 1.3
1.3.	Impact	moving axes	setting, maintenance, loading/unloading	movement envelope	1.1, 1.2, 1.3
		moving axes	monitoring	machine environment	1.1, 1.2, 1.3
1.4	Drawing-in or Trapping	moving axes of rotating aggregates	setting, maintenance	movement envelope – rotating elements of aggregates	1.1, 1.2, 1.3
1.5	Cut	handling of cut material	loading/unloading	movement envelope/ machine environment	1.1, 1.2, 1.3, 1.6

Table A.1 (continued)

No.*)	Description	Example(s) of related hazardous situation(s)	Associated activity	Related danger zone	5.2, Table 1 reference
2	Electrical hazards				
2.1	Contact of persons with live parts (direct contact)	contact with live parts or connections	during commissioning, maintenance, trouble shooting	electrical cabinet, terminal boxes, control panels, plasma cutting units	2.1
2.2	Contact of persons with live parts which have become live under faulty conditions (indirect contact)	contact with live parts or connections	during commissioning, maintenance, trouble shooting	electrical cabinet, terminal boxes, control panels, plasma cutting units	2.1, 2.2
		contact with energized plasma torch	trouble shooting	movement envelope	2.2
2.3	Contact with energized work pieces	contact with the work piece during active plasma process	loading/unloading	movement envelope	2.3
3.	Thermal hazards				
3.1	Burns	contact with hot work piece	loading/unloading	movement envelope	3.1
		contact with hot tool	maintenance, trouble shooting	movement envelope	3.2
		contact with hot slag spatter and flying sparks	monitoring	machine environment	3.3
		contact with gas flame or plasma arc	setting, maintenance, monitoring		3.4
4.	Noise hazards				
4.1	Hearing loss	sound emission by cutting process	all activities	movement envelope, machine environment	4.1
4.2	Interference with voice communication and acoustical signals	sound emission by cutting process	all activities	movement envelope, machine environment	4.2
6.	Radiation hazards				
6.1	Eye damage, loss of sight	high emission of visible, IR and UV light	monitoring	movement envelope, machine environment	6.1
		laser light	adjustment of laser pointer or measuring devices	movement envelope	6.2

Table A.1 (continued)

No.*)	Description	Example(s) of related hazardous situation(s)	Associated activity	Related danger zone	5.2, Table 1 reference
7	Material and substance hazards				
7.1	Poisoning, disease	welding and cutting fumes	all activities	movement envelope, machine environment	7.1
		cooling liquid of plasma system	maintenance	plasma torch, components of plasma system	7.2
		numbing effect of NO _x	monitoring, loading/unloading	movement envelope, machine environment	7.1
		accumulation of gases	monitoring loading/unloading	movement envelope, machine environment	7.1
7.2	Explosion	gases under pressure accumulation of explosive gases	all activities	movement envelope, machine environment, leakage of seals and connections	7.3, 7.1.3
8.	Hazards generated by neglecting ergonomic principles in the design process				
8.1	Unhealthy postures or excessive stress and effort	lifting and passing while handling work piece	loading/unloading	movement envelope, machine environment	8.1
8.2	Inadequate local lighting	judgment and accuracy of manual actions impaired during handling/ positioning of work materials or tools	setting, maintenance, trouble shooting, loading/unloading	movement envelope, machine environment	8.3
8.3	Human errors, human behaviour	Wrong combination of work material and process parameter	setting	movement envelope, machine environment	8.4
		Entering the danger zone during running process	loading/unloading	movement envelope	8.4
		inadvertent operation of controls	all activities	movement envelope, machine environment	8.4
		reasonably foreseeable misuse	all activities	movement envelope, machine environment	8.4
8.4	Inadequate design, location, or marking of actuators	inadvertent operation of controls	all activities	movement envelope, machine environment	8.5
8.5	Inadequate design or location of visual display units	misinterpretation of displayed information	all activities	movement envelope, machine environment	8.6

Table A.1 (continued)

No.*)	Description	Example(s) of related hazardous situation(s)	Associated activity	Related danger zone	5.2, Table 1 reference
9	Hazards associated with the environment in which the machine is used				
9.1	Slip, trip and fall of persons	obstacles on the floor, wet floor, slag on the floor	all activities	environment in which the machine is used	9.1
9.2	High parts of the machine which must be accessible for maintenance or trouble shooting	High parts of the machine which must be accessible from the outside of the machine for maintenance or trouble shooting	maintenance and trouble shooting	environment in which the machine is used	9.2
10	Combination of hazards				
10.1	Failure/disorder of the machine control	mechanical hazards caused by unexpected movements of the machine	setting, maintenance, trouble shooting, loading/ unloading	movement envelope	1.1.1.3, 1.1.2, 1.2, 1.3, 1.4.1, 1.4.2, 3.4
		hazards caused by unexpected start of the cutting process	setting, maintenance, trouble shooting, loading/ unloading	movement envelope	1.1.1.3, 1.1.2, 1.2, 1.3, 1.4.1, 1.4.2, 3.4
10.2	Failure of power supply	uncontrolled deceleration of the machine movement	monitoring, loading/ unloading	movement envelope	1.5
		uncontrolled leakage of gas	monitoring, setting	movement envelope, machine environment	7.1
10.3	Collision of tools with work piece	ejection of work pieces, parts of work pieces, tools or parts of tools	monitoring	movement envelope, machine environment	1.6
*) This list is derived from ISO 12100:2010, Annex B.					

Annex B (informative)

Calculation examples for dimensioning of exhaust systems

B.1 General

For values, see [Table 1](#), 7.1.2.

B.2 Example 1

Given situation

Working area: 2 000 mm · 6 000 mm, 1 plasma-cutting-system with 130 A, only vertical cutting, see [Figure B.1](#).

Cutting table: 2 100 mm · 6 180 mm, divided into 12 sections of 515 mm each.

Calculation

Necessary airflow in the active section of the table:

$$2,1 \text{ m} \cdot 0,515 \text{ m} \cdot 3\,600 \text{ (m}^3\text{/h)/m}^2 = 3,890 \text{ m}^3\text{/h}$$

Necessary airflow for leakage at 11 closed flaps (according to the specification given by the manufacturer of the table):

$$11 \text{ flaps} \cdot 40 \text{ m}^3\text{/h per flap} = 440 \text{ m}^3\text{/h}$$

Total necessary airflow:

$$3\,890 \text{ m}^3\text{/h} + 440 \text{ m}^3\text{/h} = 4,330 \text{ m}^3\text{/h}$$

B.3 Example 2

Given situation

Working area: 2 500 mm · 12 000 mm, 1 plasma-cutting-system with 260 A with bevelling system, see [Figure B.2](#).

Cutting table 2 600 mm · 12 360 mm, divided into 24 sections of 515 mm each.

Calculation

Necessary airflow in the active section of the table:

$$2,6 \text{ m} \cdot 0,515 \text{ m} \cdot 4\,100 \text{ (m}^3\text{/h)/m}^2 = 5\,500 \text{ m}^3\text{/h}$$

Necessary additional airflow for bevelling cutting:

$$2,6 \text{ m} \cdot 0,515 \text{ m} \cdot 4\,100 \text{ (m}^3\text{/h)/m}^2 \cdot 50 \% = 2\,750 \text{ m}^3\text{/h}$$

Necessary airflow to compensate the leakage at 23 closed flaps (according to the specification given by the manufacturer of the table):

$$23 \text{ flaps} \cdot 40 \text{ m}^3\text{/h per flap} = 920 \text{ m}^3\text{/h}$$

Total necessary airflow:

$$5\,500\text{ m}^3/\text{h} + 2\,750\text{ m}^3/\text{h} + 920\text{ m}^3/\text{h} = 9\,170\text{ m}^3/\text{h}$$

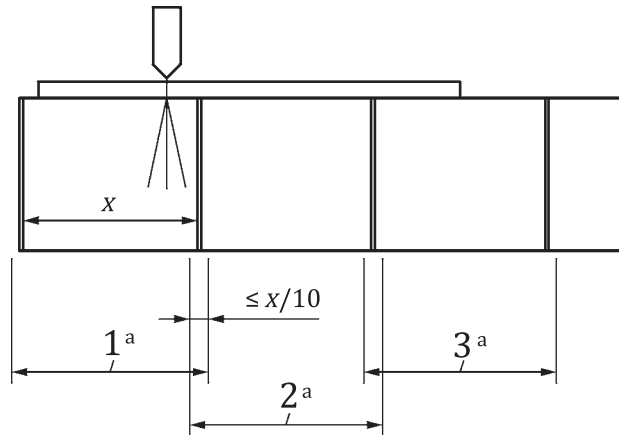

Key

- 1 section 1
- 2 section 2
- 3 section 3
- x section width
- a Active extraction zone if the respective section is active.

NOTE a describes only the width of the extraction zone. In this case, only section 1 is extracted.

Figure B.1 — Cutting table divided into sections and the overlap to the adjoining section is less than or equal to 10 %

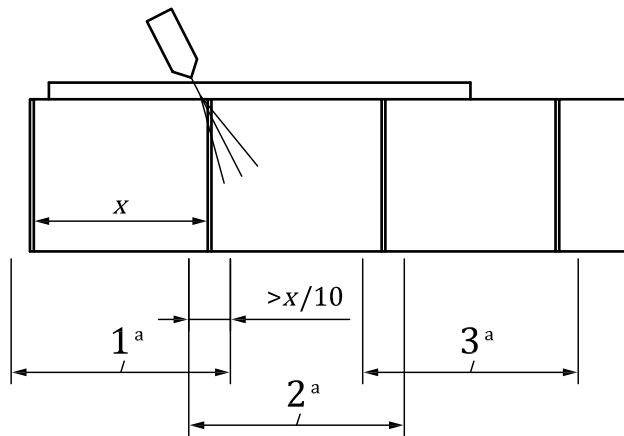

Key

- 1 section 1
- 2 section 2
- 3 section 3
- x section width
- a Active extraction zone if the respective section is active.

NOTE a describes only the width of the extraction zone. In this case only sections 1 and 2 are extracted.

Figure B.2 — Cutting table with bevelling system

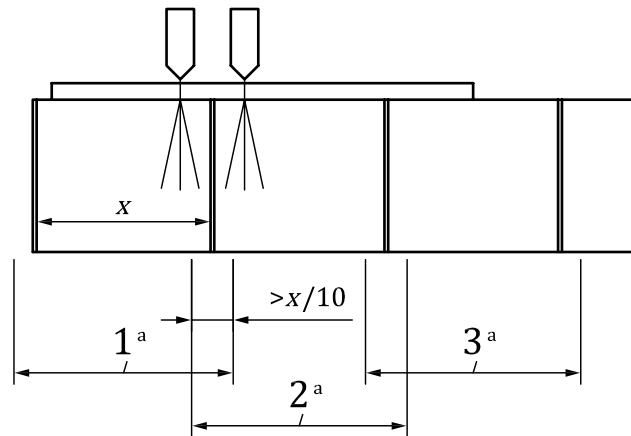
**Key**

- 1 section 1
- 2 section 2
- 3 section 3
- x section width
- ^a Active extraction zone if the respective section is active.

NOTE ^a describes only the width of the extraction zone. In this case, only sections 1 and 2 are extracted.

Figure B.3 — Cutting table using two or more torches which are not in a line

Annex C (informative)

Example for the lower limit of protective devices

In case the thickness of a work piece does not exceed 130 mm, the lower limit of the protected area shall start not more than 180 mm above the cutting table.

If the machine is designed to cut material thicker than 130 mm, the protective area shall start at a height given by the maximum allowed work piece thickness plus 50 mm, see [Figure C.1](#).

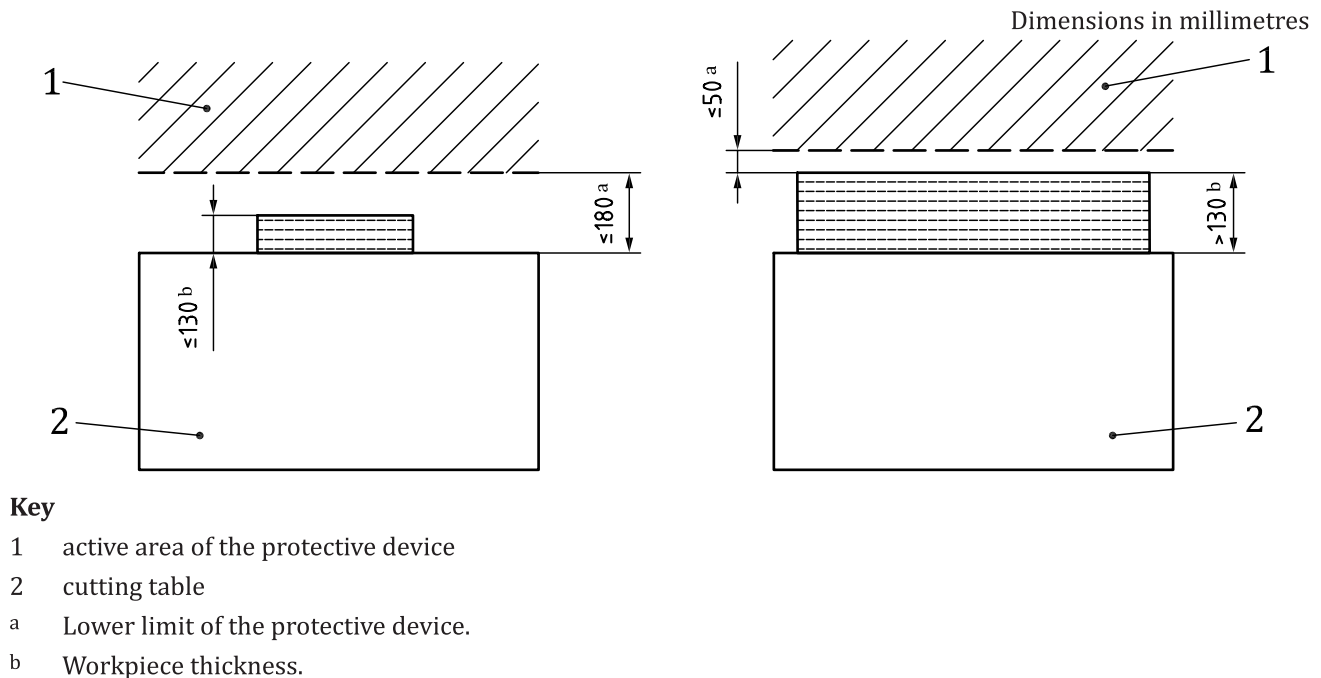

Figure C.1 — Lower limit of the protective device

Annex D (informative)

Example for calculation of the compression corresponding to the acceptable maximum force in case of collision between the machine and a human body

Hypotheses on masses of body parts for 75 kg:

— upper limbs:	5 kg
— lower limbs:	12 kg
— head and neck:	5 kg
— trunk:	18 kg
— hips:	18 kg

Hypotheses on the application of the strengths:

The strength is maximal for the following:

- the heavier parts;
- the harder parts, where the thickness of compression is the lowest.

In the case study, the unfavourable situation of a shock on a part little stuffed by muscles or adipose tissues, on a corner of the hips (iliac bones) is calculated.

Other parts of the body are considered to stay in their place or to move so little that the effort to which they are subjected is lower.

Condition to be verified, based on the acceleration of the hips from 0 to 0,25 m/s:

$$X > \frac{v_{\max}^2}{\left(2 \cdot \frac{F}{m}\right)} \quad (\text{D.1})$$

where

X is the compression given in metres;

v_{\max} is the maximum assumed speed: 0,25 m/s (\cong 15 m/min);

F is the force equal to 150 N;

m is the mass equal to 18 kg.

As a result of the calculation with the given values, X shall be greater than 3,7 mm.

Calculation of the collision area:

force, $F < 150\text{N}$

pressure, $p < 50 \text{ N/cm}^2$.

$$A = F/p \quad (\text{D.2})$$

where A is the collision area in m^2 .

From this calculation, a collision area of 3 cm^2 results.

Annex E (normative)

Measurement of the air velocity at the entrance plane of the cutting table

Perform the measurement as follows:

- a) select the table unit connected to the longest duct and then select the section farthest away from the duct entry to the selected table unit;
- b) cover the section to be measured with a plate sized as stated in the instruction manual of the cutting table or sized 50 % of the section area;
- c) the shape of the plate shall be similar to the shape of the section and shall be placed in the centre of the section according to [Figure E.1](#);
- d) measure the air velocity at the measurement points as given in [Figure E.1](#);
- e) the measured value for each point shall be higher than the indicated value according to [Table 1](#), 7.1.2.

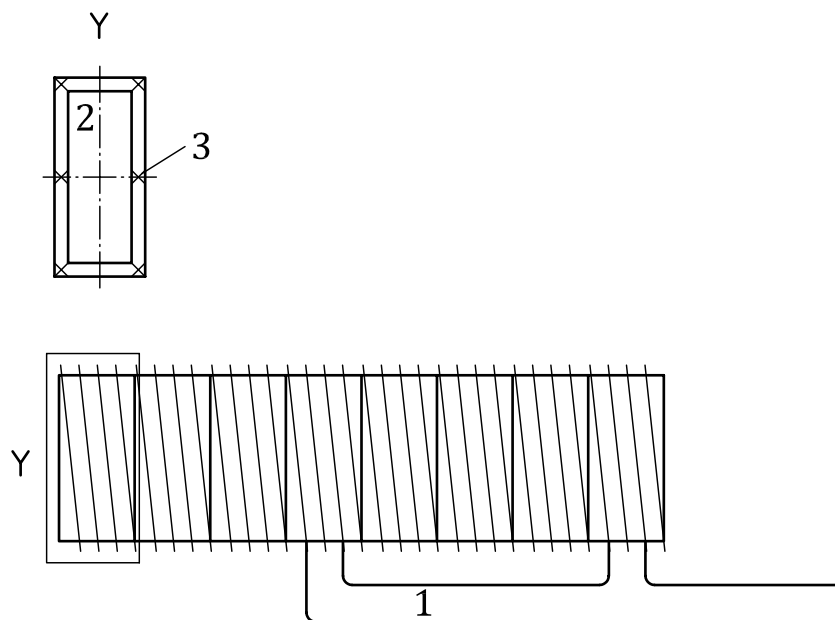

Key

- 1 longest duct
- 2 plate covering the section to be measured
- 3 measuring points

Figure E.1 — Measurement points for measuring the air velocity at the entrance plane of the cutting table

Bibliography

- [1] ISO 8206, *Acceptance tests for oxygen cutting machines — Reproducible accuracy — Operational characteristics*
- [2] ISO 9090, *Gas tightness of equipment for gas welding and allied processes*
- [3] ISO 9539, *Gas welding equipment — Materials for equipment used in gas welding, cutting and allied processes*
- [4] ISO 11553-1, *Safety of machinery — Laser processing machines — Part 1: General safety requirements*
- [5] ISO 13577-2, *Industrial furnaces and associated processing equipment — Safety — Part 2: Combustion and fuel handling systems*
- [6] ISO 14122-1, *Safety of machinery. Permanent means of access to machinery — Part 1: Choice of fixed means of access between two levels*
- [7] ISO 15667, *Acoustics — Guidelines for noise control by enclosures and cabins*
- [8] EN 560, *Gas welding equipment — Hose connections for equipment for welding, cutting and allied processes*
- [9] EN 730-1, *Gas welding equipment — Safety devices — Part 1 — Devices incorporating a flame (flashback) arrestor*
- [10] EN 874, *Gas welding equipment — Oxygen/fuel gas blowpipes (cutting machine type) of cylindrical barrel — Type of construction, general specifications, test methods*
- [11] EN 1005-2:2003+A1:2008, *Safety of machinery — Human physical performance — Part 2: Manual handling of machinery and component parts of machinery*
- [12] EN 1256, *Gas welding equipment — Specification for hose assemblies for equipment for welding, cutting and allied processes*
- [13] EN 12198-1, *Safety of machinery — Assessment and reduction of risks arising from radiation emitted by machinery — Part 1: General principles*
- [14] EN 50178, *Electronic equipment for use in power installations*
- [15] IEC 60825-1, *Safety of Laser Products — Part 1: Equipment Classifications Requirement*
- [16] IEC 61000-6-2, *Electromagnetic compatibility (EMC) — Part 6-2: Generic standards — Immunity for industrial environments*
- [17] IEC 61000-6-4, *Electromagnetic compatibility (EMC) — Part 6-4: Generic standards - Emission standard for industrial environments*
- [18] IEC 62079, *Preparations of instructions — Structuring, content and presentation*
- [19] Directive 2011/65/EU of the European Parliament and of the Council of 8 June 2011 on the restriction of the use of certain hazardous substances in electrical and electronic equipment (RoHS)

