

First edition
2009-07-01

**Non-parallel steel wire and cords for tyre
reinforcement**

Fils d'acier et cordes non parallèles pour le renfort de pneumatiques



Reference number
ISO 17832:2009(E)

© ISO 2009

PDF disclaimer

This PDF file may contain embedded typefaces. In accordance with Adobe's licensing policy, this file may be printed or viewed but shall not be edited unless the typefaces which are embedded are licensed to and installed on the computer performing the editing. In downloading this file, parties accept therein the responsibility of not infringing Adobe's licensing policy. The ISO Central Secretariat accepts no liability in this area.

Adobe is a trademark of Adobe Systems Incorporated.

Details of the software products used to create this PDF file can be found in the General Info relative to the file; the PDF-creation parameters were optimized for printing. Every care has been taken to ensure that the file is suitable for use by ISO member bodies. In the unlikely event that a problem relating to it is found, please inform the Central Secretariat at the address given below.



COPYRIGHT PROTECTED DOCUMENT

© ISO 2009

All rights reserved. Unless otherwise specified, no part of this publication may be reproduced or utilized in any form or by any means, electronic or mechanical, including photocopying and microfilm, without permission in writing from either ISO at the address below or ISO's member body in the country of the requester.

ISO copyright office
Case postale 56 • CH-1211 Geneva 20
Tel. + 41 22 749 01 11
Fax + 41 22 749 09 47
E-mail copyright@iso.org
Web www.iso.org

Published in Switzerland

Contents

Page

Foreword.....	iv
1 Scope	1
2 Normative references	1
3 Terms and definitions	1
4 Classification	2
4.1 Classification based on tensile strength	2
4.2 Classification based on cord structure	3
4.3 Classification based on cord type	4
5 Designation and ordering	4
5.1 Cord structure	4
5.2 Cord tensile strength	5
5.3 Cord type	5
5.4 Length and direction of lay	5
5.5 Coating type	5
6 Requirements	5
6.1 Dimensions, mass and tolerances	5
6.2 Welds and splices	6
6.3 Mechanical properties	7
6.4 Technological properties	7
6.5 Brass coating	7
6.6 Adhesion force	8
6.7 Constructions and properties	8
7 Sampling and inspection levels	9
7.1 Sampling	9
7.2 Inspection levels	9
8 Packing	9
8.1 Spools	9
8.2 Packaging	10

Foreword

ISO (the International Organization for Standardization) is a worldwide federation of national standards bodies (ISO member bodies). The work of preparing International Standards is normally carried out through ISO technical committees. Each member body interested in a subject for which a technical committee has been established has the right to be represented on that committee. International organizations, governmental and non-governmental, in liaison with ISO, also take part in the work. ISO collaborates closely with the International Electrotechnical Commission (IEC) on all matters of electrotechnical standardization.

International Standards are drafted in accordance with the rules given in the ISO/IEC Directives, Part 2.

The main task of technical committees is to prepare International Standards. Draft International Standards adopted by the technical committees are circulated to the member bodies for voting. Publication as an International Standard requires approval by at least 75 % of the member bodies casting a vote.

Attention is drawn to the possibility that some of the elements of this document may be the subject of patent rights. ISO shall not be held responsible for identifying any or all such patent rights.

ISO 17832 was prepared by Technical Committee ISO/TC 17, *Steel*, Subcommittee SC 17, *Steel wire rod and wire products*.

Non-parallel steel wire and cords for tyre reinforcement

1 Scope

This International Standard specifies the definition and requirements of non-parallel steel wire and cords for tyre reinforcement.

2 Normative references

The following referenced documents are indispensable for the application of this document. For dated references, only the edition cited applies. For undated references, the latest edition of the referenced document (including any amendments) applies.

ISO 2859-1, *Sampling procedures for inspection by attributes — Part 1: Sampling schemes indexed by acceptance quality limit (AQL) for lot-by-lot inspection*

ISO 3951-1, *Sampling procedures for inspection by variables — Part 1: Specification for single sampling plans indexed by acceptance quality limit (AQL) for lot-by-lot inspection for a single quality characteristic and a single AQL*

ISO 3951-2, *Sampling procedures for inspection by variables — Part 2: General specification for single sampling plans indexed by acceptance quality limit (AQL) for lot-by-lot inspection of independent quality characteristics*

ISO 3951-3, *Sampling procedures for inspection by variables — Part 3: Double sampling schemes indexed by acceptance quality limit (AQL) for lot-by-lot inspection*

ISO 3951-5, *Sampling procedures for inspection by variables — Part 5: Sequential sampling plans indexed by acceptance quality limit (AQL) for inspection by variables (known standard deviation)*

ASTM D2229-04, *Standard Test Method for Adhesion Between Steel Tire Cords and Rubber*

ASTM D2969-04, *Standard Test Methods for Steel Tire Cords*

BISFA, *Test methods for steel tyre cords*, 1995 Edition

JIS G 3510, *Testing Methods for Steel Tire Cords*

3 Terms and definitions

For the purposes of this document, the following terms and definitions apply.

3.1

filament (wire)

metal fibre with brass coating used as an individual element in a strand or cord

3.2

strand

group of filaments combined together to form a unit product for further processing

3.3
cord

formed structure composed of two or more filaments when used as an end product, or a combination of strands or filaments and strands

3.3.1
single-strand cord

cord formed by twisting two or more filaments together

3.3.2
M+N type cord

cord formed by twisting a number of non-concentric filaments around a number of parallel filaments

NOTE The cross-section is not round and varies along the length.

3.3.3
layer cord

cord formed by adding layers around a core (either filament(s) or a strand)

NOTE The layers can be filaments or strands.

3.3.4
multi-strand cord

cord formed by twisting two or more strands together

3.4
wrap

filament wound helically around a steel cord

3.5
direction of lay

helical disposition of the components of a strand or cord

NOTE 1 The strand or cord has an "S" or left-hand lay, when held vertically, if the spirals around the central axis of the strand or cord conform in direction of slope to the central portion of the letter "S".

NOTE 2 The strand or cord has a "Z" or right-hand lay if the spirals conform in direction of slope to the central portion of slope of the letter "Z".

3.6
length of lay

axial distance required to make a 360° revolution of any element in a strand or in a cord

NOTE The length of lay is expressed in millimetres.

4 Classification

4.1 Classification based on tensile strength

Steel cord is supplied in levels of tensile strength (Figure 1), designated as

- NT: normal standard (or regular) tensile strength cord,
- HT: high tensile strength cord,
- ST: super tensile strength cord, or
- UT: ultra tensile strength cord.

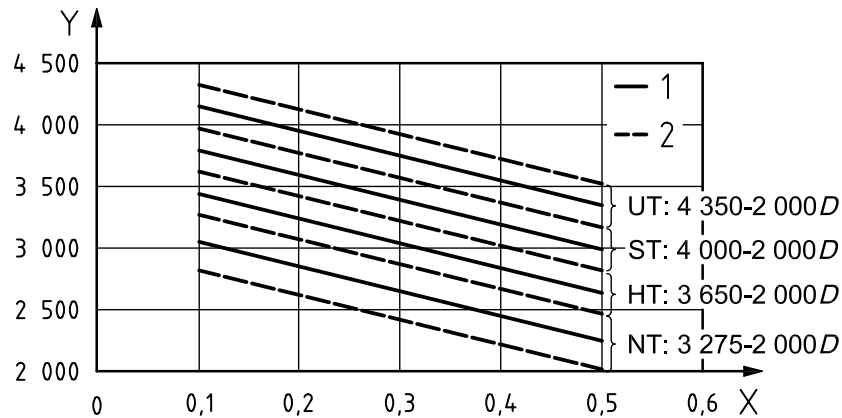

Key

- X filament diameter, mm
 Y filament tensile strength, MPa
 1 solid line indicates target value
 2 dashed line indicates tolerance range

NOTE The target value is determined by agreement between the manufacturer and purchaser.

Figure 1 — Tensile strength levels

Figure 1 gives the tensile strength levels of wet-drawn filaments. The cord breaking load will be calculated from the filament number, lay length and cabling loss. For example, for cord construction 2x0,30ST 14/S:

$$F = 2 \times (f \times \cos \alpha) \times (1 - C) \quad (1)$$

where

F is the breaking load of cord construction 2x0,30ST 14/S, in megapascals;

f is the breaking load of 0,30ST, in megapascals;

α is the cabling angle, in degrees;

C is the cabling loss on tensile strength (e.g. 4 %).

4.2 Classification based on cord structure

The main classification based on cord structure is categorized by the following four structures:

- single strand cords;
- M+N cords;
- layer cords;
- multi-strand cords.

4.3 Classification based on cord type

The main classification based on cord type is categorized by the following four types:

- HE: high-elongation cord;
- OC: open cord;
- CC: compact cord;
- SE: semi-high-elongation cord.

Another detailed classification may be used if there is mutual agreement between the manufacturer and purchaser.

5 Designation and ordering

A tyre cord construction is normally defined by

- cord structure,
- cord tensile strength,
- cord type,
- length and direction of lay, and
- coating type.

5.1 Cord structure

The description of the cord structure follows the sequence of manufacture of the cord, i.e. starting with the innermost strand or wire and moving outwards.

The full description of the cord structure is given by the following formulas:

$$(N \times X) \times D + (N \times X) \times D + (N \times X) \times D + D, \text{ or}$$

$$(N \times X) \times D / (N \times X) \times D / (N \times X) \times D + D \text{ for compact cords, and}$$

$$(N \times N) \times D + D$$

where

N is the number of strands;

X is the number of filaments;

D is the nominal diameter of wires, expressed in millimetres.

EXAMPLE 1 $(1 \times 3) \times 0,22 + (1 \times 9) \times 0,22 + (1 \times 15) \times 0,22 + 0,15$.

When N or F equals 1, they should not be included.

EXAMPLE 2 $3 \times 0,22 + 9 \times 0,22 + 15 \times 0,22 + 0,15$.

If the diameter D is the same for two or more parts in sequence, it shall only be stated at the end of the sequence.

The diameter of the spiral wrap shall always be stated separately.

EXAMPLE 3 $3 + 9 + 15 \times 0,22 + 0,15$.

When the innermost strand or wire is identical to the adjacent strand or wires, the formula may be simplified by stating only the sum of the identical components and brackets need not be used.

EXAMPLE 4 $0,22 + 6 \times 0,22 + 6 \times (0,22 + 6 \times 0,22)$ becomes $7 \times 7 \times 0,22$.

5.2 Cord tensile strength

There are 4 levels of tensile strength: NT, HT, ST and UT as defined in 4.1.

5.3 Cord type

See Table 3.

5.4 Length and direction of lay

The sequence or order in the designation follows the sequence of manufacturing, i.e. starting with the innermost strand and moving outwards.

EXAMPLE

$3 + 9 + 15 \times 0,175 + 0,15$

5/10/16/3.5 SSZS

5 S: lay length and direction of the strand $3 \times 0,175$

10 S: lay length and direction of the strand $+ 9 \times 0,175$

16 Z: lay length and direction of the strand $+ 15 \times 0,175$

3,5 S: lay length and direction of the wrap

5.5 Coating type

There are 2 types of coating: high-copper coating and normal copper coating, as listed in Table 2.

6 Requirements

Specified tests are mainly conducted in accordance with internationally agreed methods for steel tyre cords, such as ASTM D2229-04, ASTM D2969-04, BISFA, JIS G 3510, etc.

6.1 Dimensions, mass and tolerances

6.1.1 Diameter of cord

The diameter of the circumscribed circle of cord, in millimetres, and detailed requirements are listed in Table 5.

6.1.2 Linear density

The linear density, i.e. the mass of a 1 m length of cord, in grams per metre (g/m), and detailed requirements are listed in Table 5.

6.1.3 Tolerances

The tolerance of the cord length shall conform to Table 1.

Tolerance of filament diameter: $\pm 10 \mu\text{m}$.

Tolerance of lay length: $\pm 10 \%$.

Tolerance of residual torsion of cord: ± 3 torsions/6 m in general; ± 4 torsions/6 m for high-elongation cord.

Table 1 — The tolerance of the cord length

Dimension in metres

Cord length, L	Tolerance
$L < 500$	± 10
$500 \leq L < 4\ 000$	± 40
$4\ 000 \leq L < 10\ 000$	± 50
$10\ 000 \leq L$	$\pm 0,5 \%$ (max. 100)

6.2 Welds and splices

Continuous lengths shall be supplied as follows:

- a) Cord may be welded and shall withstand a minimum load as follows:
 - for NT cord: 40 % of the breaking load of the cord;
 - for HT, ST, UT cord and off-the-road cords: 30 % of the breaking load of the cord.

An additional bending test is needed for the control of the welds.

In the case of layer cords, splicing or a simple knot filament connection can be used in lieu of welds, except in the outer-most layer.

- b) The increase in diameter of the finished weld or splicing shall not exceed the cord diameter by more than 10 % (or 20 %, if agreed between the manufacturer and the purchaser).
- c) The number of cord welds shall not exceed:
 - 3 per spool type BS40 or BS60;
 - 6 per spool type BS80;
 - 30 % of spools per box (based on 72 BS40/60 spools per box or 36 BS80 spools per box).

The dimensions of typical spool types are shown in Table 3.

6.3 Mechanical properties

6.3.1 Breaking load and elongation at fracture

A specimen of cord is clamped in a tensile-testing apparatus under a defined pre-tension and is subjected to a constant rate of extension until the cord breaks; if the specimen has a spiral wrap, it shall be removed from the length of the specimen in contact with the clamps.

Only clamps which do not cause fractures in the vicinity of the clamped area shall be used.

6.3.2 Structural elongation

Structural elongation (e.g. part load elongation at 2,5 N to 50 N) is the increase in length between defined tension levels, expressed as a percentage of the original gauge length.

6.4 Technological properties

6.4.1 Straightness

The steel cord sample is put on a smooth surface on which two parallel lines 6 m long and 75 mm apart are marked. The steel cord sample should stay between the two lines.

6.4.2 Arc height

After releasing the end of the specimen used for the residual torsion determination, the arc height, expressed in millimetres, at a specified inter-distance shall be measured.

The specified inter-distance may be 300 mm or 400 mm.

6.4.3 Residual torsion

One end of a specified length of cord is allowed to turn freely: the number of revolutions is counted as residual torsion and the direction is noted.

6.4.4 Flare

The flare of the end of the specimen should not be more than the length of the lay or the amount which might influence the process-ability and/or the laboratory test, such as the adhesion test.

6.4.5 Steel cord elasticity

Steel cord elasticity, expressed as a percentage, is the degree to which a cord reverts to its original form after having been subjected to a specific bending deformation.

6.4.6 Rubber penetration

Determination of the degree of rubber penetration shall be done on a rubber-embedded steel cord sample.

6.5 Brass coating

The wire should be uniformly and continuously coated with brass. The thickness and the composition of the coating are listed in Table 2.

6.5.1 Mass fraction of brass coating

The mass of brass coating is the mass of brass per unit of sample, expressed in grams per kilogram.

6.5.2 Thickness of coating

The relationship between the thickness (*t*) and the mass of brass coating (*w*) is expressed in Equation 2:

$$t = 0,235 \times w \times d \tag{2}$$

where

- t* is the thickness of the coating, in micrometres (µm);
- d* is the diameter of the filament, in millimetres (mm);
- w* is the mass of brass coating, in grams per kilogram (g/kg).

6.5.3 Composition of brass

The mass fraction of copper in the brass coating is expressed as a percentage (see Table 2).

Table 2 — Thickness and copper mass fraction of brass coating

Type of coating	Diameter of filament (<i>d</i>) mm	Coating mass (<i>w</i>) g/kg	Thickness (<i>t</i>) µm	Mass fraction of copper in brass %
High-copper coating	All diameters	5 ± 1,5		67,5 ± 2,5
Normal copper coating	<i>d</i> < 0,27		0,20 ± 30 %	63,5 ^a ± 2,5 ^b
	0,27 ≤ <i>d</i> ≤ 0,32		0,24 ± 30 %	63,5 ^a ± 2,5 ^b
	0,32 < <i>d</i>		0,30 ± 30 %	63,5 ^a ± 2,5 ^b
^a For a normal copper coating, the mean value may be 63 or 64, depending on the customer's specification.				
^b For a normal copper coating, the tolerance may be ± 3,0, depending on the customer's specification.				

6.6 Adhesion force

The test method used shall be agreed between the manufacturer and purchaser. The rubber compound used shall be provided by the customer, together with relevant information about the time and temperature for vulcanization.

6.7 Constructions and properties

The main constructions of the steel cord, the typical mechanical properties and the dimensions including the linear density, in grams per metre (g/m), are shown in Table 5.

However, the values of mechanical properties and dimensions stated in Table 5 may be changed in accordance with an agreement between the manufacturer and purchaser.

The construction not stated in Table 5 may be manufactured in accordance with an agreement between the manufacturer and purchaser. In this case, the mechanical properties and dimensions shall be decided in accordance with an agreement between the manufacturer and purchaser.

The value of the breaking load in UT constructions shall be decided in accordance with an agreement between the manufacturer and purchaser.

7 Sampling and inspection levels

7.1 Sampling

For sampling, ISO 3951-1, ISO 3951-2 and ISO 3951-3 shall be used; for variables, ISO 3951-5 shall be used; and for attributes, ISO 2859-1 shall be used.

7.2 Inspection levels

The inspection level is dependent on the capability, e.g. Cpk (short-term process capability), Ppk (long-term process capability), and has to be reviewed on a regular basis. Exact Cpk and/or Ppk levels on different steel cord properties may be defined between the manufacturer and purchaser.

8 Packing

The product needs to be packed adequately to ensure safe transportation, handling and correct arrival conditions in the customer warehouse. In that respect, the necessary precautions to avoid any damage, deterioration, contamination and determination of the product should be taken.

The shelf-life should be 6 months.

The humidity should be less than 30 %. A stricter humidity threshold may be agreed upon between the manufacture and purchaser.

All units are provided with a desiccant and a humidity indicator. Cartons to be shipped can be stored for 6 months inside a warehouse where the combination of temperature and humidity does not lead to condensation. It is recommended to condition the units at ambient temperature before they are opened.

If either shelf-life or humidity are exceeded, adhesion should be retested.

8.1 Spools

Tire cord is wound on metal spools, as specified in Figure 2 and Table 3.

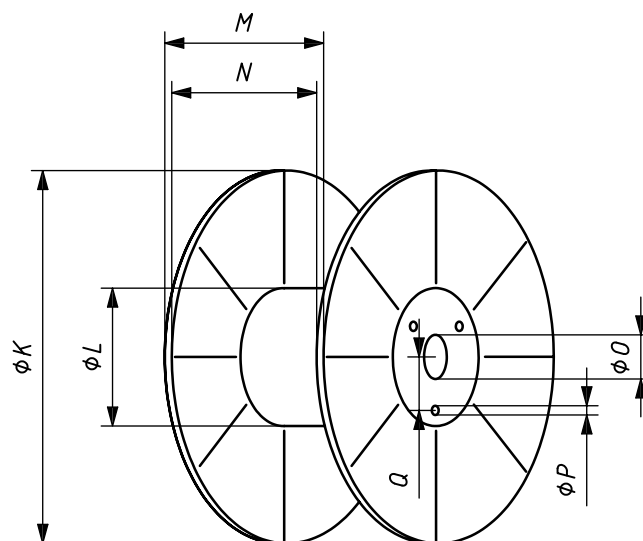

Figure 2 — Spool dimension

Table 3 — Examples of dimensions and mass in typical spools

Symbol	Dimension and mass	Type			
		BS40	BS60	BS80/17	BS80/33
K	Diameter of flange (mm)	255	255	255	255
L	Diameter of barrel (mm)	117	117	117	177
M	Overall width (mm)	167	167	329	329
N	Traverse (mm)	153	153	315	315
O	Bore diameter (mm)	17	33	17	33
P	Number × diameter of driver-hole (mm)	3 × 13	3 × 13	3 × 13	3 × 13
Q	Distance driver-hole/bore (mm)	38	43	2/38 + 1/43	43
Approximate mass (kg)		1,85	1,90	2,40	2,50
Approximate cord capacity (kg)		18	18	36	36

8.2 Packaging

The tire cord spools are packed in a waterproof carton strapped to a pallet in units of approximately 1 300 kg net mass. Dimensions of one unit (including pallet) are 1 080 mm (length) × 810 mm (width) × 1 200 mm (height). The pallet is made of wood or plastic. Some internationally recognized packaging styles are listed in Table 4 and Figure 3.

Table 4 — Example of packaging

Type of spools	Composition	Number of spools	Approximate tare without pallet kg
BS40	4 × 3 × 6	72	157
BS60	4 × 3 × 6	72	161
BS80/17 - BS80/33	4 × 3 × 3	36	113



Figure 3 — Example of packaging

Table 5 — Construction and mechanical properties of the steel cord

Cord construction	Type	Lay length mm	Lay direction	Breaking load, N												Elongation at break %		
				NT			HT			ST			UT				Diameter mm	Linear density g/m
				Min.	Aim		Min.	Aim		Min.	Aim		Min.	Aim				
2 × 0,30		14	S	325	355	405	445	437	470	445		0,63	0,60	1,18	1,12			
2 + 1 × 0,28		∞16/	-S	450	485	515	555	550	595			0,76	0,70	1,54	1,47			
2 + 1 × 0,30		∞16/	-S	490	530	615	660	650	700			0,81	0,75	1,76	1,68			
2 + 2 × 0,25		∞14/14/	-SS	490	530	560	605	595	650			0,70	0,65	1,63	1,55			
2 + 2 × 0,28		∞16/16/	-SS	610	660	685	740					0,9	0,73	2,04	1,94			
2 + 2 × 0,30		∞16/16/	-SS	660	715	825	870	855	920			0,87	0,81	2,34	2,23			
2 + 2 × 0,32		∞16/16/	-SS	745	805	860	930					0,92	0,85	2,70	2,57			
2 + 2 × 0,35		∞16/16/	-SS	880	950	980	1 060					1,07	0,99	3,18	3,05			
2 + 2 × 0,38		∞16/16/	-SS	1 000	1 080	1 165	1 260					1,08	1,00	3,74	3,60			
3 + 2 × 0,30		∞16/16/	-SS			905	1 035					0,97	0,90	2,93	2,79			
3 + 2 × 0,35		∞16/16/	-SS			1 265	1 370	1 405	1 520	1 623		1,16	1,07	4,01	3,82			
0,20 + 18 × 0,175	CC	12,5	Z	1 210	1 280	1 385	1 470	1 520	1 610	1 635		0,95	0,90	3,86	3,71			
0,22 + 18 × 0,20	CC	12,5	Z	1 510	1 600	1 715	1 820	1 865	1 980			1,07	1,02	5,03	4,84			
0,25 + 18 × 0,22	CC	16	Z	1 805	1 920	2 065	2 190					1,19	1,13	6,08	5,85			
12 × 0,22 + 0,15	CC	12,5/3,5	SZ	1 170	1 250							1,24	1,18	4,03	3,84			
12 × 0,22 + 0,15	CC	12,5/5	SZ			1 330	1 420					1,24	1,18	4,00	3,82			
12 × 0,22	CC	12,5	S	1 170	1 250	1 330	1 420					0,96	0,91	3,82	3,64			
2 + 7 × 0,22		6,3/12,5	SS	825	920	1 000	1 060	1 090	1 165			0,87	0,83	2,88	2,74			
2 + 7 × 0,22 + 0,15		6,3/12,5/5	SSZ	825	920	1 000	1 060	1 090				1,13	1,08	3,05	2,90			
2 + 7 × 0,28		8/16	SS	1 295	1 390	1 530	1 635	1 688	1 805			1,14	1,06	4,67	4,45			
3 × 0,20/9 × 0,175 + 0,15	CC	10/5	SZ	800	855	950	1 020					1,07	1,02	2,78	2,67			
3 × 0,20/9 × 0,175	CC	10	S	800	855	950	1 020					0,79	0,75	2,61	2,49			

Table 5 (continued)

Cord construction	Type	Lay length mm	Lay direction	Breaking load, N										Elongation at break %		
				NT		HT		ST		UT		Diameter mm			Linear density g/m	
				Min.	Aim	Min.	Aim	Min.	Aim	Min.	Aim	Max.	Aim		Max.	Aim
3 × 0,20 + 6 × 0,35		10/18	SS			1 620	1 840					1,19	1,13	5,61	5,25	
3 × 0,20 + 6 × 0,35		10/18	SZ	1 510	1 620	1 620	1 840					1,19	1,13	5,61	5,34	
3 × 0,22/9 × 0,20 + 0,15	CC	12,5/5	SZ	1 025	1 095	1 200	1 270	1 240	1 330	1 375		1,17	1,11	3,50	3,33	
3 × 0,22/9 × 0,20	CC	12,5	S	1 025	1 095	1 200	1 270	1 240	1 330		0,92	0,88	3,33	3,17		
3 × 0,27/9 × 0,25 + 0,15	CC	14/5	SZ			1 710	1 830				1,35	1,29	5,33	5,08		
3 × 0,32/9 × 0,30 + 0,15	CC	18/5	SZ			2 385	2 560				1,56	1,49	7,55	7,19		
3 × 0,35/9 × 0,32 + 0,15	CC	18/5	SZ			2 710	2 910				1,74	1,66	8,72	8,30		
0,22 + 6 + 12 × 0,20		6,3/12,5	ZZ			1 775	1 880				1,07	1,02	5,05	4,86		
0,25 + 6 + 12 × 0,225		7,5/16	ZZ			2 150	2 280				1,21	1,15	6,38	6,14		
3 + 8 × 0,33		10/20	SS					2 770	2 980		1,41	1,34	7,91	7,55		
3 + 9 × 0,175 + 0,15		5/10/3,5	SSZ	755	800	840	900				1,05	1,00	2,61	2,49		
3 + 9 × 0,22		6,3/12,5	SS	1 130	1 210	1 300	1 390				0,97	0,92	3,83	3,65		
3 + 9 × 0,22 + 0,15		6,3/12,5/3,5	SSZ	1 130	1 210	1 300	1 390				1,25	1,19	4,01	3,85		
3 + 9 + 15 × 0,175		5/10/16	SSZ	1 620	1 720	1 955	1 970				1,12	1,07	5,38	5,20		
3 + 9 + 15 × 0,175 + 0,15		5/10/16/3,5	SSZS	1 620	1 720	1 955	1 970				1,41	1,34	5,61	5,42		
3 + 9 + 15 × 0,22		6,3/12,5/18	SSZ	2 600	2 750	2 900	3 100				1,42	1,35	8,53	8,24		
3 + 9 + 15 × 0,22 + 0,15		6,3/12,5/18/3,5	SSZS	2 600	2 750	2 900	3 070				1,70	1,62	8,0	8,50		
3 × 4 × 0,22	HE	3,0/6,3	SS	945	1 010						1,21	1,14	4,16	3,96		5,5
4 × 4 × 0,22	HE	3,5/5	SS	1 150	1 220						1,43	1,35	5,62	5,40		5,5

Table 5 (continued)

Cord construction	Type	Lay length mm	Lay direction	Breaking load, N												Elongation at break %				
				NT			HT			ST			UT				Diameter mm		Linear density g/m	
				Min.	Aim		Min.	Aim		Min.	Aim		Min.	Aim			Max.	Aim	Max.	Aim
3 × 6 × 0,22	HE	3,5/6,3	SS	1 370	1 450										1,59	1,50	6,29	6,05	5	
3 × 7 × 0,20	HE	3,9/6,3	SS	1 325	1 430										1,42	1,34	6,00	5,80	6,5	
3 × 7 × 0,22	HE	4,5/8	SS	1 690	1 790										1,61	1,52	7,26	6,95	6,5	
3 × 2 × 0,35	SE	3,9/10	SS	1 100	1 175										1,51	1,42	5,13	4,89	5	
4 × 2 × 0,35	SE	3,9/10	SS	1 390	1 490										1,69	1,59	6,83	6,59	5	
7 × 7 × 0,22		12,5/20	SZ	4 650	4 900	5 120	5 390								2,08	1,98	15,63	15,10		
7 × 7 × 0,22 + 0,15		12,5/20/5	SZS	4 650	4 900	5 120	5 390								2,35	2,24	15,73	15,20		
7 × 7 × 0,25 + 0,15		12,5/20/5	SZS	5 800	6 100	6 350	6 700								2,65	2,52	20,49	19,75		
7 × (3 + 9 × 0,245) + 0,20		6,3/12,5/6,3/12,5/28/5	ZZSSSZS			9 000	10 750								3,57	3,40	34,23	33,07		
7 × (3 + 9 + 15 × 0,175) + 0,20		5/10/16/5/10/16/38/5	SSSZZSZ			11 470	12 400								3,78	3,60	38,81	37,50		
7 × (3 + 9 + 15 × 0,245) + 0,245		6,3/12,5/18/55/5	ZZSZ			22 385	24 200								5,08	4,80	76,49	73,90		

Copyright International Organization for Standardization

ICS 77.140.65; 83.160.01

Price based on 13 pages