**Testing methods for pervious
concrete —**

**Part 1:
Infiltration rate**

Méthodes d'essai pour ciments perméables —

Partie 1: Taux d'infiltration



COPYRIGHT PROTECTED DOCUMENT

© ISO 2016, Published in Switzerland

All rights reserved. Unless otherwise specified, no part of this publication may be reproduced or utilized otherwise in any form or by any means, electronic or mechanical, including photocopying, or posting on the internet or an intranet, without prior written permission. Permission can be requested from either ISO at the address below or ISO's member body in the country of the requester.

ISO copyright office
Ch. de Blandonnet 8 • CP 401
CH-1214 Vernier, Geneva, Switzerland
Tel. +41 22 749 01 11
Fax +41 22 749 09 47
copyright@iso.org
www.iso.org

Contents

	Page
Foreword	iv
1 Scope	1
2 Terms and definitions	1
3 Symbols	1
4 Principle	1
5 Apparatus	2
5.1 General	2
5.2 Apparatus for making the specimen	2
5.3 Apparatus for testing infiltration rate	2
6 Sampling	3
7 Procedure	3
8 Calculation	4
9 Test report	4
Bibliography	6

Foreword

ISO (the International Organization for Standardization) is a worldwide federation of national standards bodies (ISO member bodies). The work of preparing International Standards is normally carried out through ISO technical committees. Each member body interested in a subject for which a technical committee has been established has the right to be represented on that committee. International organizations, governmental and non-governmental, in liaison with ISO, also take part in the work. ISO collaborates closely with the International Electrotechnical Commission (IEC) on all matters of electrotechnical standardization.

The procedures used to develop this document and those intended for its further maintenance are described in the ISO/IEC Directives, Part 1. In particular the different approval criteria needed for the different types of ISO documents should be noted. This document was drafted in accordance with the editorial rules of the ISO/IEC Directives, Part 2 (see www.iso.org/directives).

Attention is drawn to the possibility that some of the elements of this document may be the subject of patent rights. ISO shall not be held responsible for identifying any or all such patent rights. Details of any patent rights identified during the development of the document will be in the Introduction and/or on the ISO list of patent declarations received (see www.iso.org/patents).

Any trade name used in this document is information given for the convenience of users and does not constitute an endorsement.

For an explanation on the meaning of ISO specific terms and expressions related to conformity assessment, as well as information about ISO's adherence to the WTO principles in the Technical Barriers to Trade (TBT) see the following URL: [Foreword - Supplementary information](#)

The committee responsible for this document is ISO/TC 71, *Concrete, reinforced concrete and pre-stressed concrete*, Subcommittee SC 1, *Test methods for concrete*.

ISO 17785 consists of the following parts, under the general title *Testing methods for pervious concrete*:

— *Part 1: Infiltration rate*

Testing methods for pervious concrete —

Part 1: Infiltration rate

1 Scope

This part of ISO 17785 specifies the procedure for testing the infiltration rate of hardened pervious concrete pavement specimens in the laboratory. It is not a method for measuring the permeability of pervious concrete. The specimens can either be prepared in the laboratory or cored from field placements, but not representing field conditions. This part of ISO 17785 also specifies procedures to make and cure hardened pervious concrete samples in the laboratory.

2 Terms and definitions

For the purposes of this document, the following terms and definitions apply.

2.1

infiltration rate

water flow rate per area per time through pervious concrete

2.2

pervious concrete

concrete which has interconnected voids that allow for water flow through them

Note 1 to entry: Pervious concrete for pavement is usually made with little or no fine aggregate and contains narrowly graded coarse aggregate typically with the nominal maximum size of 10 mm. The nominal size can be less or more, but the nominal maximum size is 25 mm.

2.3

pre-wet

wetting specimens before test representing field conditions with antecedent precipitation

Note 1 to entry: This pre-wet condition typically represents the condition of the minimum flow rate.

3 Symbols

k infiltration rate (mm/s)

W volume of infiltrated water (mm³)

A cross-sectional area of specimen (mm²)

t time required for measured volume of water to infiltrate the concrete (s)

4 Principle

The test specimens are pre-wetted before the test. A given amount of water is poured into the specimen and the time for the water to infiltrate is measured.

5 Apparatus

5.1 General

The apparatus shall consist of the following:

- a) apparatus for making the specimen in the laboratory (as noted herein) or received as a core from the field;
- b) equipment for preparing and measuring the test specimens.

5.2 Apparatus for making the specimen

5.2.1 Balance or scale, accurate to 5 g.

5.2.2 Scoop, of a size large enough so that each amount of pervious concrete obtained from the sampling receptacle is representative and small enough so that the concrete is not spilled during placement in the measure.

5.2.3 Mould, cylindrical container made of steel or other suitable material with an inside diameter of 100 mm and a height of 100 mm.

The mould shall be made of non-absorbent material which does not react with cement paste and its internal surface shall have a smooth finish (see Note). The mould shall be substantial enough to hold its form without distortion and shall be substantially leak-proof. Measure and record the inner diameter of the mould to the nearest 1 mm.

NOTE Materials that have been found to be suitable include steel, aluminium, rigid plastic and PVC.

5.2.4 Coring machine, machine to obtain cylindrical cores with a minimum diameter of 100 mm and a minimum height of 100 mm.

5.2.5 Shrink wrap, heat shrink plastic film (see Note).

Shrink wrap shall be made of non-absorbent material which does not react with cement paste.

NOTE Shrink wrap materials are made of polymer plastic film. When heat is applied, the plastic wrap shrinks tightly around the specimen.

5.3 Apparatus for testing infiltration rate

5.3.1 Water container, cylindrical container typically made of plastic with a volume of at least 2 000 ml and from which water may be easily poured at a controlled rate into the funnel.

5.3.2 Funnel, watertight and sufficiently rigid to the frame (see [Figure 1](#)), which shall have a capacity of 200 ml.

5.3.3 Stopwatch or clock, accurate to 0,1 s.

5.3.4 Water, potable water.

5.3.5 Heat gun, air heating system to fully wrap the specimens by heating the shrink wrap.

6 Sampling

The test shall be performed with a minimum of three similar specimens. The specimens shall be made based on the specifications applicable to the project and area of construction.

7 Procedure

7.1 Making the test specimen in the laboratory: A test specimen shall have a minimum diameter of 100 mm. There are two options for preparing the specimen, one with the specimen having a vertical porosity distribution representative of a field placement and the other with a more even porosity in the vertical direction.

7.1.1 For the test specimen with a typical porosity distribution, the concrete shall be poured in one layer and consolidated with a rammer or a vibrator. After consolidation is complete, the side of the mould is lightly tapped with a wooden or plastic hammer to remove foam generated by the compaction rod.

7.1.2 For the test specimen with a more even porosity in the vertical direction, the concrete shall be poured in layers and consolidated with a rammer or a vibrator after each layer. For specimens with a diameter of 100 mm and height of 200 mm, there shall be three layers. After consolidation is complete, the side of the mould is lightly tapped with a wooden or plastic hammer to remove foam generated by the compaction rod.

7.1.3 The specimens shall be immediately covered after consolidation.

7.1.4 Curing: The specimens shall remain in the covered mould and the mould shall be removed after a minimum curing period of seven days.

7.2 Obtaining test specimen from the field: Cut cores the full depth of the pervious concrete slab. Cores are to have a minimum diameter of 100 mm.

7.3 Wrapping: Wrap the specimen with three layers of shrink wrap and tape the full length of the vertical seam. Trim the wrap at a level even with the bottom of the specimen and leave at least a 50 mm lip on the top to hold the minimal head.

7.4 Heating shrink wrap: Heat the wrap with a heat gun to tighten the wrap on the vertical surface of the sample. This should prevent the flow of water between the wrap and the exterior of the sample. Do not heat the top 50 mm lip. The inner surface of the wrap shall be marked or scored with two lines at a distance of 15 mm and 25 mm from the top of the sample.

7.5 Pre-wetting: Place the specimen upright in the funnel to allow water to freely flow out of the bottom. Pour water into the specimen at a rate sufficient to maintain a head between the two marked lines. Use a total of 1 000 ml of water for 100 mm diameter specimens.

7.6 Pour the water into the specimen at a rate sufficient to maintain a head between the two marked lines and until the measured amount of water has been used. Begin timing as soon as the water impacts the pervious concrete surface. Stop timing when free water is no longer present on the pervious surface. The test shall be started within 5 min of the completion of the pre-wetting. Record the amount of water (2 000 ml for 100 mm diameter specimens) to the nearest 10 ml. Record the testing duration (t) to the nearest 0,1 s.

8 Calculation

The infiltration rate shall be calculated as given in [Formula \(1\)](#):

$$k = \frac{W}{A \cdot t} \quad (1)$$

9 Test report

In the event of a report being prepared, the following information shall be included:

- a) identification of the sample;
- b) identification of the specimen;
- c) whether specimens were made in the laboratory or received as a core from the field;
- d) details on how the specimen was prepared and cured in the laboratory;
- e) specimen dimensions and density (both designed and measured);
- f) age of specimen at test;
- g) volume of water poured onto the specimen during test (mm³);
- h) time required for the measured amount of water to infiltrate into the concrete (s);
- i) infiltration rate (mm/s).

Dimensions in millimetres

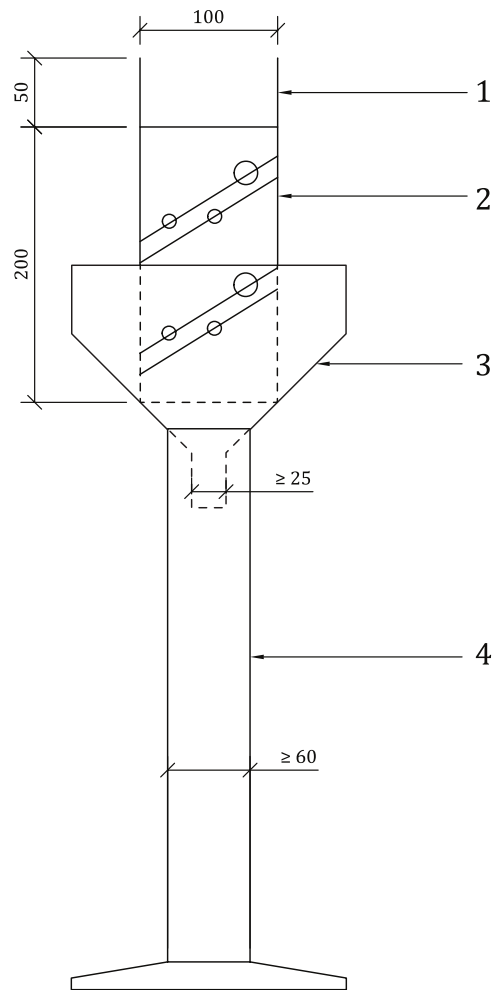

Key

- 1 shrink wrap
- 2 test specimen
- 3 funnel
- 4 graduated cylinder

Figure 1 — Test setup and dimensions

Bibliography

- [1] ASTM C1701/C1701M, *Standard Test Method for Infiltration Rate of In Place Pervious Concrete*

