

---

---

**Textiles — Quantitative analysis  
of cashmere, wool, other specialty  
animal fibers and their blends —**

**Part 2:  
Scanning electron microscopy method**

*Textiles — Analyse quantitative du cachemire, de la laine, d'autres  
fibres animales spéciales et leurs mélanges —*

*Partie 2: Méthode par microscopie électronique à balayage*



**COPYRIGHT PROTECTED DOCUMENT**

© ISO 2016, Published in Switzerland

All rights reserved. Unless otherwise specified, no part of this publication may be reproduced or utilized otherwise in any form or by any means, electronic or mechanical, including photocopying, or posting on the internet or an intranet, without prior written permission. Permission can be requested from either ISO at the address below or ISO's member body in the country of the requester.

ISO copyright office  
Ch. de Blandonnet 8 • CP 401  
CH-1214 Vernier, Geneva, Switzerland  
Tel. +41 22 749 01 11  
Fax +41 22 749 09 47  
copyright@iso.org  
www.iso.org

# Contents

Page

<b>Foreword</b> .....	<b>iv</b>
<b>Introduction</b> .....	<b>v</b>
<b>1 Scope</b> .....	<b>1</b>
<b>2 Terms and definitions</b> .....	<b>1</b>
<b>3 Principle</b> .....	<b>2</b>
<b>4 Apparatus, materials, and reagents</b> .....	<b>2</b>
4.1 Apparatus.....	2
4.2 Materials.....	2
4.3 Reagents.....	3
<b>5 Sample drawing</b> .....	<b>3</b>
<b>6 Preparation of test specimens</b> .....	<b>3</b>
6.1 Number of test specimens.....	3
6.2 Preparation method for test specimens of various types of samples.....	3
6.2.1 Loose fibre.....	3
6.2.2 Sliver.....	4
6.2.3 Yarn.....	4
6.2.4 Woven fabrics.....	5
6.2.5 Knitted fabrics.....	5
6.3 Coating the specimens.....	5
<b>7 Test procedure</b> .....	<b>5</b>
7.1 Test on each specimen stub.....	5
7.2 Qualitative analysis (purity analysis) and determination of fibre content.....	5
<b>8 Calculation of test result</b> .....	<b>6</b>
<b>Annex A (informative) Drawing of lot sample and laboratory sample</b> .....	<b>7</b>
<b>Annex B (informative) Surface morphology of common animal fibres</b> .....	<b>8</b>
<b>Annex C (normative) Density of common animal fibres</b> .....	<b>47</b>
<b>Bibliography</b> .....	<b>48</b>

## Foreword

ISO (the International Organization for Standardization) is a worldwide federation of national standards bodies (ISO member bodies). The work of preparing International Standards is normally carried out through ISO technical committees. Each member body interested in a subject for which a technical committee has been established has the right to be represented on that committee. International organizations, governmental and non-governmental, in liaison with ISO, also take part in the work. ISO collaborates closely with the International Electrotechnical Commission (IEC) on all matters of electrotechnical standardization.

The procedures used to develop this document and those intended for its further maintenance are described in the ISO/IEC Directives, Part 1. In particular the different approval criteria needed for the different types of ISO documents should be noted. This document was drafted in accordance with the editorial rules of the ISO/IEC Directives, Part 2 (see [www.iso.org/directives](http://www.iso.org/directives)).

Attention is drawn to the possibility that some of the elements of this document may be the subject of patent rights. ISO shall not be held responsible for identifying any or all such patent rights. Details of any patent rights identified during the development of the document will be in the Introduction and/or on the ISO list of patent declarations received (see [www.iso.org/patents](http://www.iso.org/patents)).

Any trade name used in this document is information given for the convenience of users and does not constitute an endorsement.

For an explanation on the meaning of ISO specific terms and expressions related to conformity assessment, as well as information about ISO's adherence to the WTO principles in the Technical Barriers to Trade (TBT) see the following URL: [Foreword - Supplementary information](#)

The committee responsible for this document is ISO/TC 38, *Textiles*.

ISO 17751 consists of the following parts, under the general title *Textiles — Quantitative analysis of cashmere, wool, other speciality animal fibres and their blends*:

- *Part 1: Light microscopy method*
- *Part 2: Scanning electron microscopy method*

## Introduction

Cashmere is a high value speciality animal fibre, but cashmere and other animal wool fibres such as sheep's wool, yak, camel, etc. exhibit great similarities in their physical and chemical properties so that their blends are difficult to distinguish from each other by both mechanical and chemical methods. In addition, these fibres show similar scale structures. It is very difficult to accurately determine the fibre content of such fibre blends by current testing means.

Research on the accurate identification of cashmere fibres has been a long undertaking. At present, the most widely used and reliable identification techniques include the light microscopy (LM) method and the scanning electron microscopy (SEM). The SEM method shows complementary characteristics to those of LM method.

- The advantage of the LM method is that the internal medullation and pigmentation of fibres can be observed; the disadvantage is that some subtle surface structures cannot be clearly displayed. A decolouring process needs to be carried out on dark samples for testing. An improper decolouring process can affect the judgment of the fibre analyst.
- The SEM method shows opposite characteristics to those of LM method so some types of fibres need to be identified by scanning electron microscope.

The LM and SEM methods need be used together to identify some difficult-to-identify samples in order to utilize the advantages of both methods.

It has been proven in practice that the accuracy of a fibre analysis is highly related to the ample experience, full understanding, and extreme familiarity of the fibre analyst to the surface morphology of various types of animal fibres so besides the textual descriptions, several micrographs of different types of animal fibres are given in Annex B.



# Textiles — Quantitative analysis of cashmere, wool, other specialty animal fibers and their blends —

## Part 2: Scanning electron microscopy method

### 1 Scope

This part of ISO 17751 specifies a method for the identification, qualitative, and quantitative analysis of cashmere, wool, other speciality animal fibres, and their blends using scanning electron microscopy (SEM).

This part of ISO 17751 is applicable to loose fibres, intermediate products, and final products of cashmere, wool, other speciality animal fibres, and their blends.

### 2 Terms and definitions

For the purposes of this document, the following terms and definitions apply.

#### 2.1

##### **specialty animal fibre**

any type of keratin fibre taken from animal (hairs) other than sheep

#### 2.2

##### **scanning electron microscope**

intermediate type of microscopic morphology observation instrument between transmitted electron microscope and light microscope which use a focused beam of high-energy electrons to generate a variety of physical information signals

Note 1 to entry: The principle consists of scanning a primary focused electron beam over a whole area of interest on the surface of solid specimen and the signal derived from which is then received, amplified, and displayed in images for full observation of surface area topography of the specimen.

Note 2 to entry: The signals obtained by a scanning electron microscope are, e.g. *secondary electrons* (2.3), Auger electrons, characteristic X-ray, etc.

#### 2.3

##### **secondary electron**

low-energy extra-nuclear electron released from and by ionization of a metal atom in the 5 nm to 10 nm scanned region of metal layer less than 10 nm thick nearest to the outermost meta-coated surface of a specimen under impact of the focused primary electron beam of energy in units of tens of keV

Note 1 to entry: Being surface sensitive because of the small mean free path of the electron to escape from deep within the specimen and, therefore, the signal of which produces the highest-resolution morphological images of the coated surface.

#### 2.4

##### **scale**

cuticle covering the surface of animal fibres

#### 2.5

##### **scale frequency**

number of *scales* (2.4) along the fibre axis per unit length

**2.6**

**scale height**

height of the cuticle at the *scale's* (2.4) distal edge

**2.7**

**fibre surface morphology**

sum of the physical properties/attributes characterizing the fibre surface

EXAMPLE The fibre surface morphology includes *scale frequency* (2.5), *scale height* (2.6), patterns of scale edge, scale surface, smoothness, fibre evenness along its axis, transparency under light microscope, etc.

**2.8**

**lot sample**

portion representative of the same type and same lot of material drawn according to requirements from which it is taken

**2.9**

**laboratory sample**

portion drawn from a *lot sample* (2.8) according to requirements to prepare specimens

**2.10**

**test specimen**

portion taken from fibre snippets randomly cut from a *laboratory sample* (2.9) for measurement purposes

### **3 Principle**

A longitudinal view image of fibre snippets representative of a test specimen coated with a thin layer of gold is produced by a scanning electron microscope through scanning the side surface of the test specimen with a focused incident beam of high-energy electrons, detecting signals of secondary electrons emitted by the gold atoms excited when hit by the incident electron beam, and combining the beam position with the detected signals which contain information on surface topography of the test specimen.

All fibre types found in the test specimen are identified by comparing them with known fibre surface morphologies for different types of animal fibres.

For each fibre type, the number and mean diameter of fibre snippets are counted and measured. The mass fraction is calculated from the data for the number of fibre snippets counted, mean value, and standard deviation of the snippet diameter and the true density of each fibre type.

### **4 Apparatus, materials, and reagents**

#### **4.1 Apparatus**

**4.1.1 Scanning electron microscope**, comprised of a vacuum system, electronic optical system, signal collecting and imaging system, display system, and measurement software.

**4.1.2 Sputter coater with a gold cathode.**

#### **4.2 Materials**

**4.2.1 Microtome.**

**4.2.2 Glass tube**, 10 mm to 15 mm in diameter.



- 4.2.3 **Stainless-steel rod**, approximately 1 mm in diameter.
- 4.2.4 **Glass plate**, measuring approximately 150 mm × 150 mm.
- 4.2.5 **Double-sided adhesive tape**.
- 4.2.6 **Tweezers, scissors**.
- 4.2.7 **Specimen stub**, aluminium or brass, 13 mm in diameter.
- 4.2.8 **Razor blade**.

### 4.3 Reagents

- 4.3.1 **Acetone (analytical grade)**
- 4.3.2 **Ethyl acetate (analytical grade)**.

## 5 Sample drawing

Draw the lot and laboratory samples in accordance with the sampling method given in Annex A.

## 6 Preparation of test specimens

### 6.1 Number of test specimens

Prepare five specimen stubs. The fibre snippets on the specimen stubs shall be sufficient to ensure that at least 1 000 fibres are examined.

### 6.2 Preparation method for test specimens of various types of samples

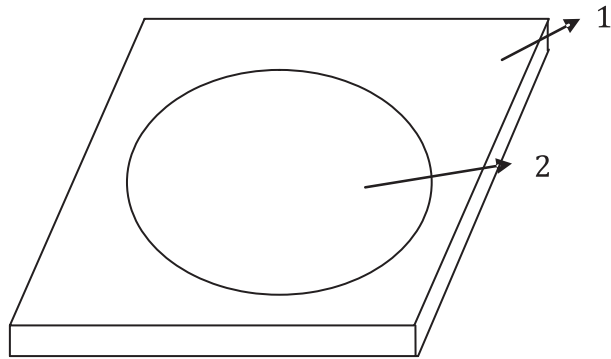
#### 6.2.1 Loose fibre

**6.2.1.1** Place the laboratory sample flat on the test table, pick up approximately 500 mg of fibres randomly on not less than 20 spots with tweezers (4.2.6) from the top and bottom sides of the sample. Blend them homogeneously, and divide them into three equal portions. Sort those drawn fibres into basically parallel fibre bundles.

**6.2.1.2** Cut the fibre bundle in the middle with a microtome (4.2.1) to get approximately 0,4 mm long fibre snippets. Cut only once in each of the fibre bundles.

**6.2.1.3** Collect all fibre snippets in the glass tube (4.2.2) and suspend them in 1 ml to 2 ml acetone (4.3.1) or ethyl acetate (4.3.2) by stirring the mixture with a stainless steel rod (4.2.3). Pour the suspension onto a glass plate (4.2.4) to ensure that the fibre snippets are uniformly distributed on a spot of approximately 10 cm in diameter on the glass plate as shown in [Figure 1](#).

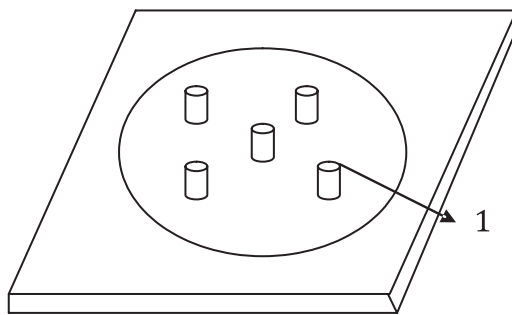
**6.2.1.4** Press the double-edged adhesive (4.2.5) on the mounting stubs and use a razor blade (4.2.8) to trim the tape away from around the mounting stubs. After all the acetone (4.3.1) or ethyl acetate (4.3.2) in the fibre snippets suspension has evaporated, press the mounting stubs with the adhesive tape end onto the glass plate (4.2.4) at the positions shown in [Figure 2](#). Transfer the uniformly mixed fibre snippets to the adhesive tape (4.2.5) on the specimen stub (4.2.7).



**Key**

- 1 glass plate
- 2 fibre snippets

**Figure 1 — Fibre suspension on glass plate**



**Key**

- 1 specimen stub

**Figure 2 — Positions of specimen stubs**

If the fibre snippets have aggregated after the evaporation of the acetone (4.3.1) or ethyl acetate (4.3.2), they shall be recollected by scraping them off the glass plate (4.2.4) with a razor blade (4.2.8) and repeat procedures 6.2.1.3 and 6.2.1.4.

**6.2.2 Sliver**

**6.2.2.1** Cut the laboratory sliver sample into three sections. Take out an appropriate amount of the fibre bundle in the longitudinal direction from each sliver section.

**6.2.2.2** Cut in the middle of each fibre bundle to obtain approximately 0,4 mm long fibre snippets with a microtome (4.2.1). Cut only once in each fibre bundle.

**6.2.2.3** Other operating procedures are the same as those stipulated in 6.2.1.3 and 6.2.1.4.

**6.2.3 Yarn**

**6.2.3.1** Divide the laboratory sample into three equal portions.

**6.2.3.2** Cut each portion in the middle with a microtome (4.2.1) to obtain approximately 0,4 mm long fibre snippets. Cut only once in each yarn portion.

**6.2.3.3** Other operating procedures are the same as those stipulated in [6.2.1.3](#) and [6.2.1.4](#).

#### **6.2.4 Woven fabrics**

**6.2.4.1** If the warp and weft yarn share the same composition, all the yarn segments unravelled from a square sample of a complete pattern may be cut to obtain an appropriate test specimen. For those fabric samples composed of different compositions of warp and weft yarns, unravel the warp and weft yarns and weigh them separately. (If the fabrics have a definite repetition in the pattern, unravel at least the integral multiple of a complete pattern.)

**6.2.4.2** Cut once from the parallel yarn portion in the middle with a microtome ([4.2.1](#)) to obtain approximately 0,4 mm long fibre snippets. Cut only once in each yarn segments.

**6.2.4.3** Other operating procedures are the same as those stipulated in [6.2.1.3](#) and [6.2.1.4](#).

#### **6.2.5 Knitted fabrics**

**6.2.5.1** Unravel at least 25 yarn segments from the laboratory sample for woollen knitted fabrics. Unravel at least 50 yarn segments for worsted knitted fabrics. Cut each yarn portion in the middle to obtain approximately 0,4 mm long fibre snippets. Cut only once in each yarn portion.

**6.2.5.2** Other operating procedures are the same as those stipulated in [6.2.1.3](#) and [6.2.1.4](#).

### **6.3 Coating the specimens**

Use the sputter coater ([4.1.2](#)) to apply a thin layer of gold to the specimens on specimen stub ([4.2.7](#)).

## **7 Test procedure**

### **7.1 Test on each specimen stub**

**7.1.1** Place a stub with the specimen into the test chamber of the SEM. First, view the selected stub at a lower magnification (for example, at  $\times 10$ ). Then, selecting an area near the upper left edge of the stub on the monitor, set the magnification to  $\times 1\,000$ , scan the stub and observe the fibres. Identify the fibre types according to the characteristics of the fibre morphologies (see details in Annex B) of cashmere, sheep's wool, and other animal fibres.

**7.1.2** Return to the lower magnification after identifying all fibres in the selected area. Choose another observation area along the vertical or horizontal direction. Repeat the above operation until finished, scanning the entire stub before continuing on to analyse fibre snippets on another stub.

### **7.2 Qualitative analysis (purity analysis) and determination of fibre content**

**7.2.1** Examine 150 fibres on the first specimen stub ([4.2.7](#)). The following three conditions may happen.

- Case 1: If only one fibre type is found, examine another 300 fibre snippets on a second stub. If no fibre of a second type is found, the sample is declared as pure.
- Case 2: If two fibre types are found and the amount of one type is lower than 3 % by number (less than five fibres of the second type), it is considered as a minor component. Examine 300 further snippets from the second stub and calculate the percentage by number of the two types of fibres.
- Case 3: If two fibre types are found and the content of each type is higher than 3 % by number, the fibre mixture is considered to be a blend. Perform a quantitative analysis according to [7.2.2](#).

7.2.2 Quantitative analysis of fibre blends.

If the sample is found to be a blend, examine 220 further fibres and measure the diameters of the first 25 fibres of each component identified (or all fibres of that component, if less than 20) on each of the remaining stubs. At least 1 030 fibres shall be identified for a sample and 100 measurements of fibre diameter made for each component. The mean fibre diameter of each component is calculated according to the diameters measured for the 100 fibres. If the total amount of each component is less than 100, calculate the mean fibre diameter according to the actual number of that fibre component.

This diameter is measured in a vacuum condition and is not comparable to a diameter measured by other instruments. So the value shall only be used for calculation of fibre content of each component in [Clause 8](#).

8 Calculation of test result

8.1 Calculate the mass fraction of each component using Formula (1).

$$w_i = \frac{N_i (D_i^2 + S_i^2) \rho_i}{\sum [N_i (D_i^2 + S_i^2) \rho_i]} \times 100 \tag{1}$$

where

- $w_i$  is the mass fraction of the component, %;
- $N_i$  is the number of fibres counted for the component;
- $S_i$  is the standard deviation for mean diameter of the component, in micrometres (µm);
- $D_i$  is the mean diameter of the component, in micrometres (µm);
- $\rho_i$  is the density of the component, in grams per millilitre (g/ml).

NOTE The density of various types of animal fibres is given in Annex C.

8.2 The mass fraction of a given fibre component in woven fabric samples may be calculated through Formula (2).

$$w_i = \frac{w_{iT} \times m_T + w_{iW} \times m_W}{m_T + m_W} \times 100 \tag{2}$$

where

- $w_i$  is the mass fraction of the component in the woven fabric sample, %;
- $w_{iT}$  is the mass fraction of the component in the warp yarns of the woven fabric sample, %;
- $m_T$  is the mass of the warp yarn in the woven fabric sample;
- $w_{iW}$  is the mass fraction of the component in weft yarns of woven fabric sample, %;
- $m_W$  is the mass of the weft yarn in the woven fabric sample.

## **Annex A**

### **(informative)**

## **Drawing of lot sample and laboratory sample**

### **A.1 Loose fibre**

Fifty percent of the total number of packages should be sampled. Take out a bundle of fibres from at least three parts of each package. After blending them homogeneously, divide the sample into two equal portions, one portion randomly selected is retained and the other is rejected.

After mixing the retained portion to ensure it is homogenized, divide it again into two equal portions in the same way. Reject one portion (selected at random).

Continue the subdivision procedure until about 20 g of fibres remain; this is the lot sample.

Divide the 20 g fibre lot sample into two portions — use one portion as the laboratory sample and retain the other as a spare sample.

### **A.2 Sliver**

Take one 30 cm long sliver from a ball top or a sliver can. Randomly, take four such slivers altogether. Strip each of the four slivers in its longitude direction to form another sliver, which is the laboratory sample. Retain the remaining portions as spare samples.

### **A.3 Yarn**

Take twenty 20 cm long woollen yarn segments from each of five different cones or skeins to obtain 100 woollen yarn segments.

Take twenty 20 cm long worsted yarn segments from each of ten different cones or skeins to obtain 200 worsted yarn segments.

Cut the yarn bundle in the middle to get two portions — use one portion as a laboratory sample and retain the other as a spare sample.

### **A.4 Woven fabrics**

Take three trapezoidal samples each measuring 5 cm × 10 cm (warp × weft) from places which are 10 cm from the edges of the fabric. For each sample, mark its warp and weft directions respectively. (Cut at least the integral multiple of a complete pattern in the case of fabrics where there is a definite repetition of the pattern.) Cut along the weft direction from the middle of each fabric sample and divide it into two portions — use one as the laboratory sample and retain the other as a spare sample.

### **A.5 Knitted fabrics**

Take three samples each measuring 5 cm × 10 cm (transverse × longitudinal). Avoid rib sections such as cuff or bottom parts. Cut each sample from the middle along the longitudinal direction into two portions — use one as the laboratory sample and retain the other as a spare sample.

## Annex B (informative)

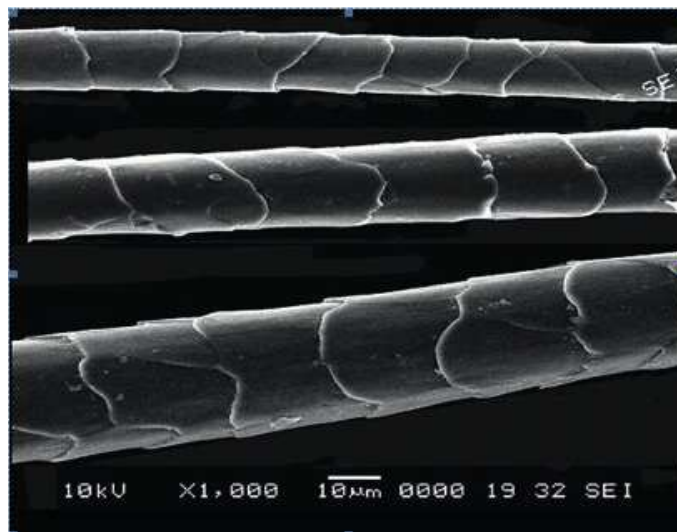
### Surface morphology of common animal fibres

#### B.1 Cashmere from China

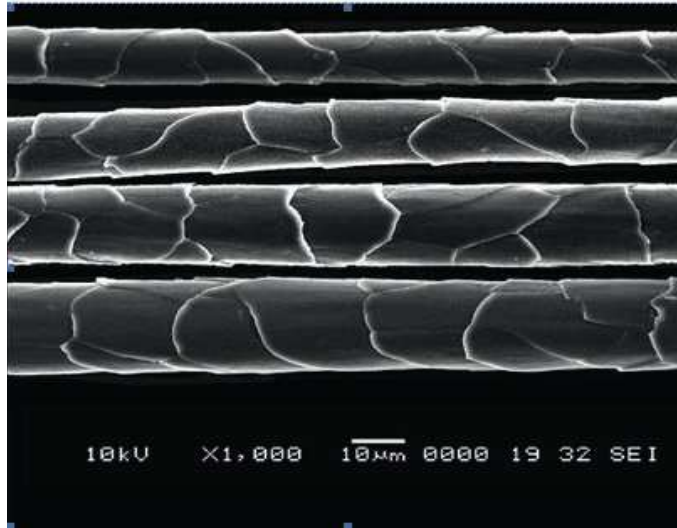
##### B.1.1 Typical ring-shaped morphology

See [Figures B.1](#) to [B.10](#).

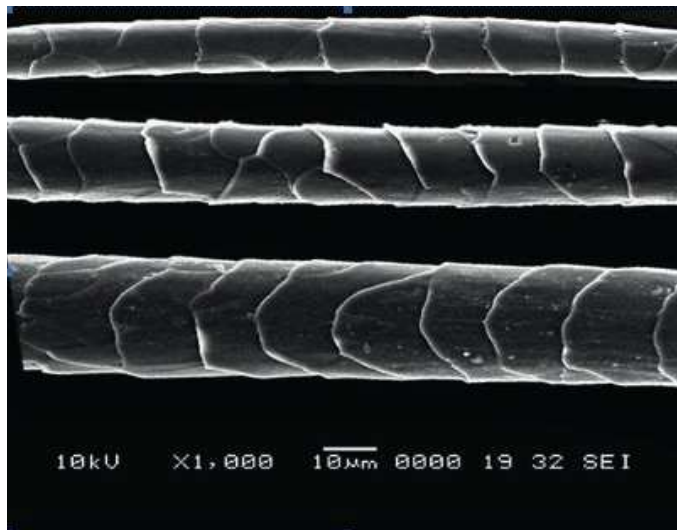
This cashmere has a high fibre diameter evenness in its axial direction and good lustre. The fibre scales are regular, most are ring-shaped and a few irregular ring-shaped; few variations can be seen. The scale envelops the fibre shaft flatly and evenly; scales are thin with smooth surfaces. The distance between adjacent scales is large. The mean scale height is less than 0,4  $\mu\text{m}$ . The mean scale frequency is between 54 scales/mm and 64 scales/mm.



**Figure B.1 — Scales encircle fibre shaft flatly and regularly with regular patterns and smooth surface**

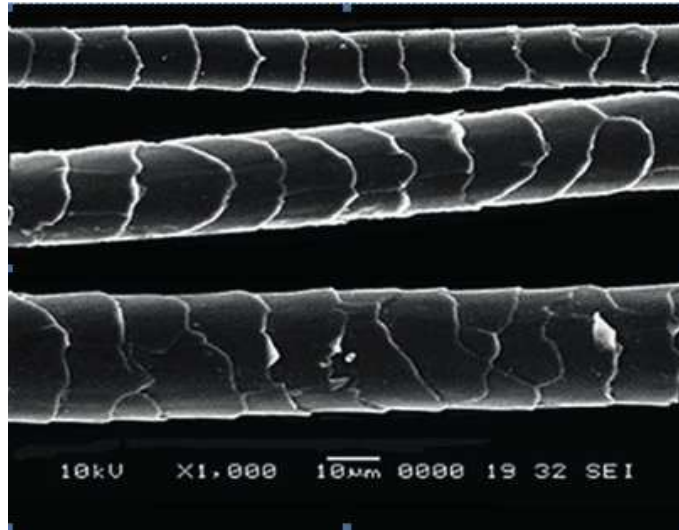


**Figure B.2 — Some scale patterns are slightly irregular**

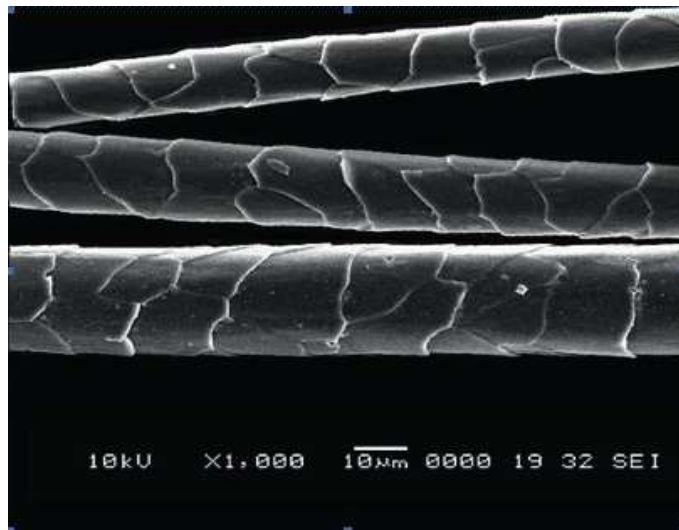


**Figure B.3 — Scale frequencies from low to high**





**Figure B.4 — Scale frequencies are slightly high**



**Figure B.5 — Scale edges are serrated**



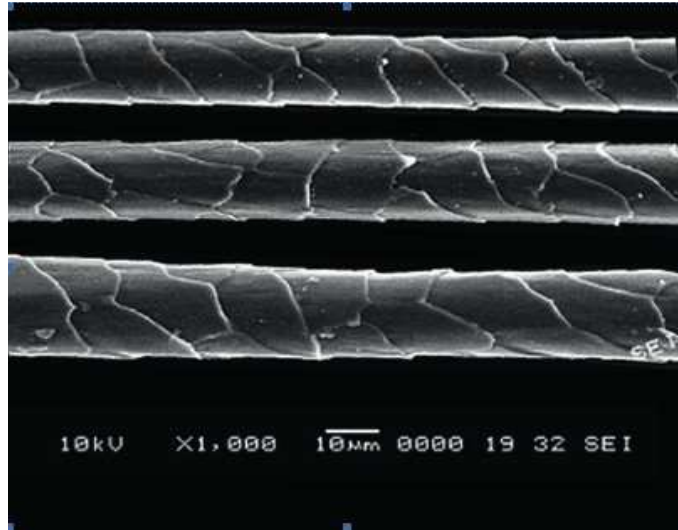


Figure B.6 — Scales are slightly slantwise and thick

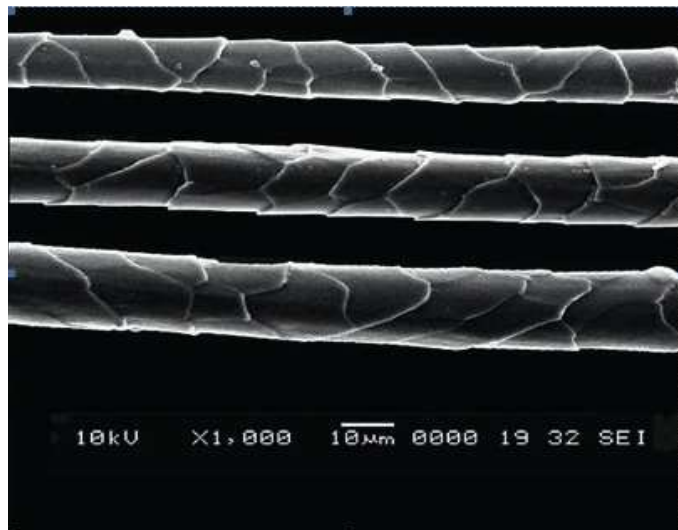
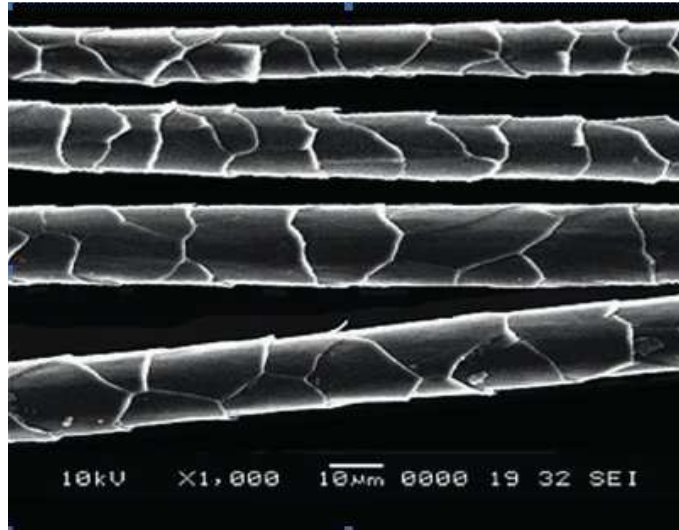
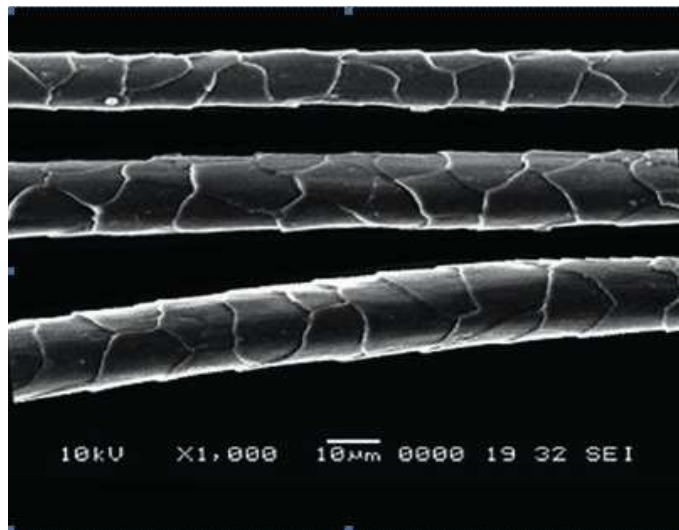


Figure B.7 — High scale frequency with irregular scale edges



**Figure B.8 — Scale edges slightly warp outward**



**Figure B.9 — Thicker scale edges with irregular scale patterns**

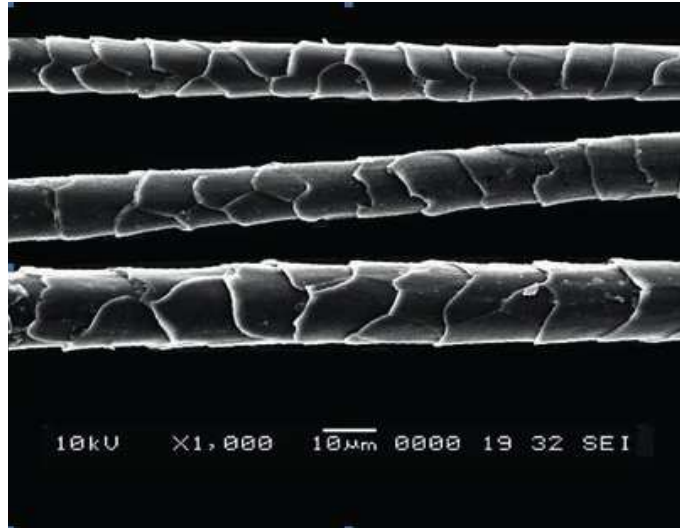


Figure B.10 — Thicker scale edges and higher scale frequency

### B.1.2 Irregular ring-shaped morphology

See [Figures B.11](#) to [B.14](#).

**Irregular ring-shaped morphology of cashmere fibres:** The scale morphology of this type is slightly different from that of a typical ring-shaped morphology. Some scale patterns are not regular, scale edges are not orderly, or scale edges are thick with high scale frequency; however, scales wrap around the fibre shaft flatly and orderly with smooth surfaces and high fibre evenness in the shaft's longitudinal direction.

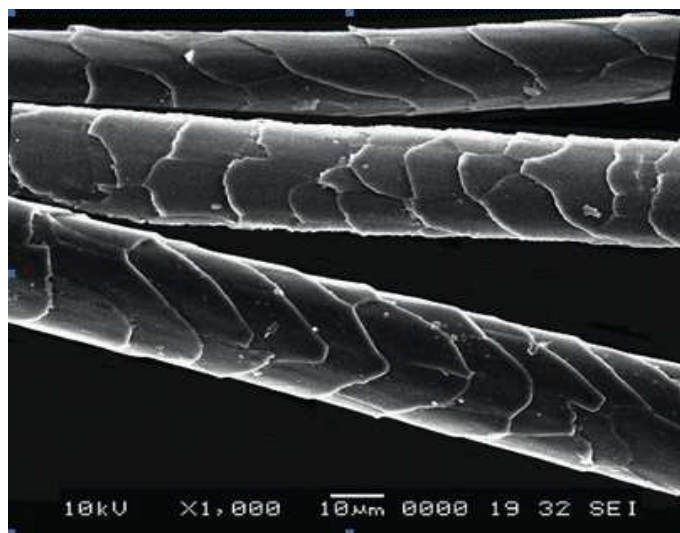


Figure B.11 — Higher fibre frequency with slightly slantwise scales

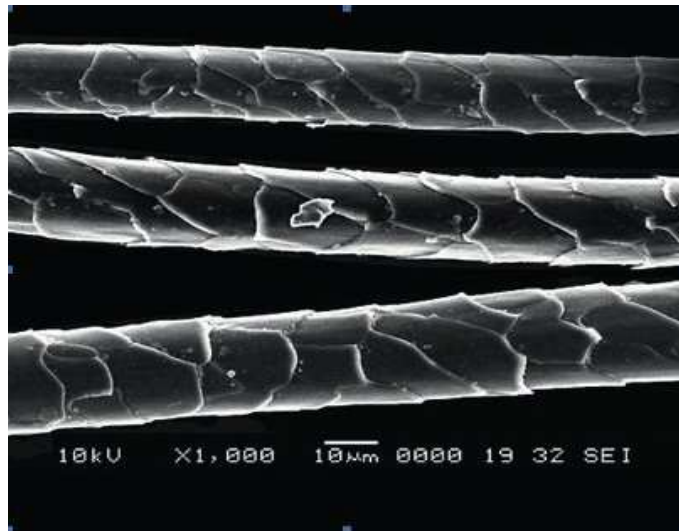


Figure B.12 — Larger scale height and higher scale frequency

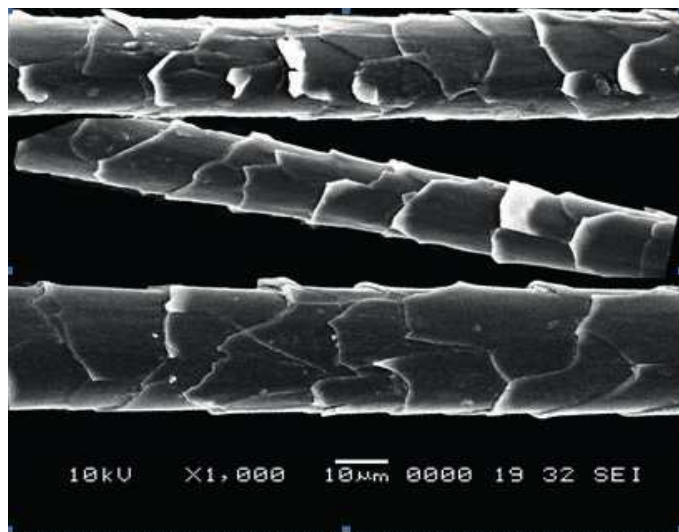
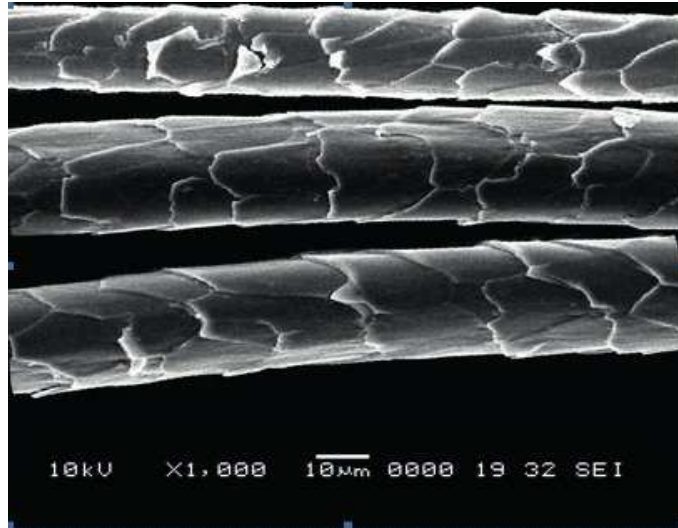


Figure B.13 — Irregular scale patterns with scale edges warping outwards



**Figure B.14 — Furrows on scale surface with serrated edges**

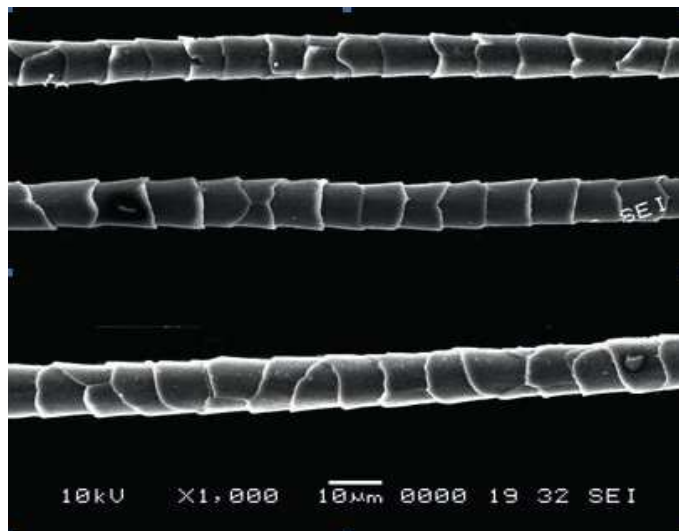
### B.1.3 Morphology of variation cashmere fibres

See [Figures B.15](#) to [B.18](#).

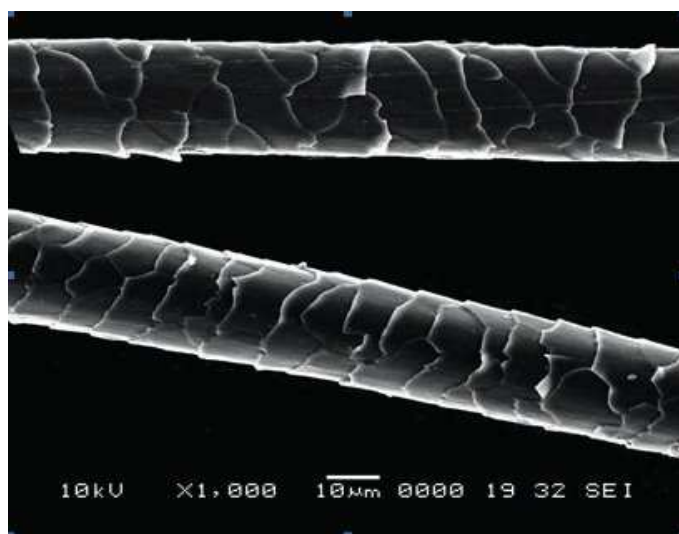
The term “morphology of variation cashmere fibres” refers to fibre morphologies deviating from those of cashmere fibres and belonging to morphologies which are difficult to distinguish or easy to be misidentified as wools.

If cashmere fibres with such morphologies are encountered in the testing process, the following conditions should be taken into consideration.

- a) When testing pure cashmere samples: To determine whether fibre with such morphology is variation cashmere or blended wool is based on the condition that whether wool is blended into the samples.
  - 1) If wool is not artificially blended into the sample, fibres with variation morphologies can be identified as variation cashmere.
  - 2) If wool is deliberately blended into the sample, fibres with variation morphologies should be identified according to the corresponding characteristics of cashmere and wool including scale structure (scale frequency, scale height, scale patterns), longitudinal fibre evenness, fibre lustre, etc. In some technical literature, a scale height of more than 0,5  $\mu\text{m}$  is more likely to be associated with wool while a scale height of less than 0,5  $\mu\text{m}$  is more likely to be associated with cashmere.
- b) When testing cashmere/wool blend samples: Identify in accordance with the above mentioned principle of deliberate adulteration of sheep’s wool to decide whether it’s cashmere or sheep’s wool.

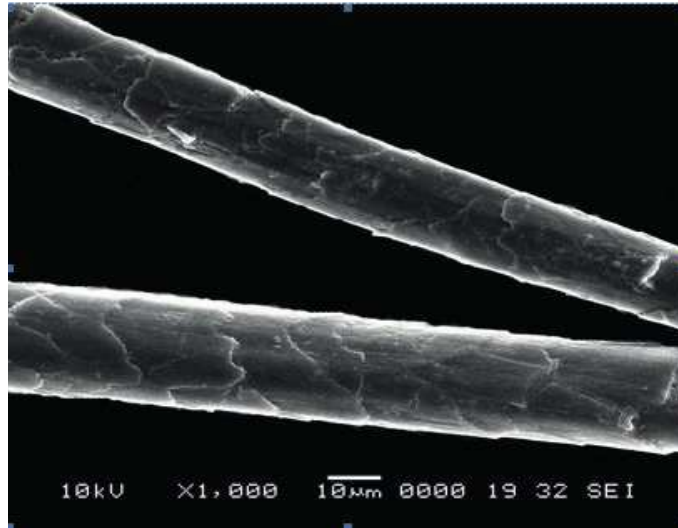


**Figure B.15 — Flowerpot-like scale patterns with high scale frequency resembling those characteristics of fine Merino wool**

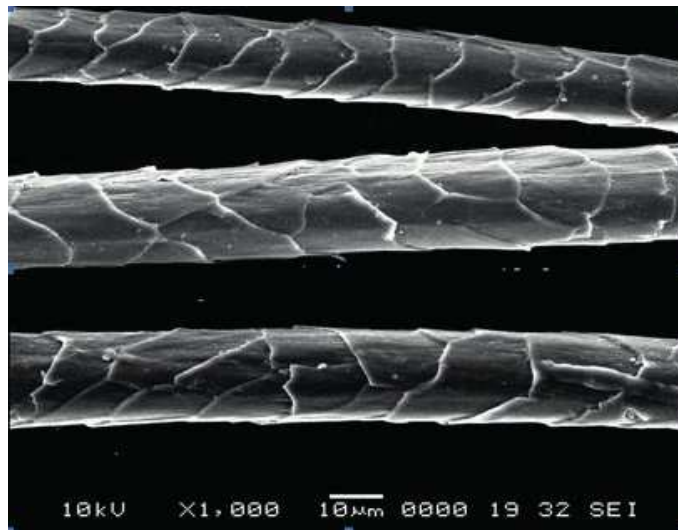


**Figure B.16 — Scales are very thin but scale frequency is very high, belongs to transitional type from down cashmere to goat coarse hair**





**Figure B.17 — Scales shed to varying degrees, scale patterns are blurry**



**Figure B.18 — Thick scales enclose fibre shaft unevenly with furrows on fibre surface showing bad lustre resembling characteristics of Chinese native sheep's wool**

## B.2 Cashmere from Mongolia

See [Figures B.19](#) to [B.28](#).

Almost all cashmeres from Mongolia are pigmented cashmere showing blurry scale patterns on the whole. Their fibre lustre is not as good as that of the Chinese cashmeres. In all the batches of samples from which these micrographs were taken, it was observed that the scales were partially broken and that the scales warp outward. However, Mongolian cashmere shows more consistent fibre morphologies.

The mean scale height of the Mongolian cashmere is 0,46  $\mu\text{m}$  and the mean scale frequency is 59,4 scales/mm.

No further classification of Mongolian cashmere fibre morphology types is made because the scale morphologies are relatively consistent. Micrographs are shown according to fibre morphologies from good to bad.

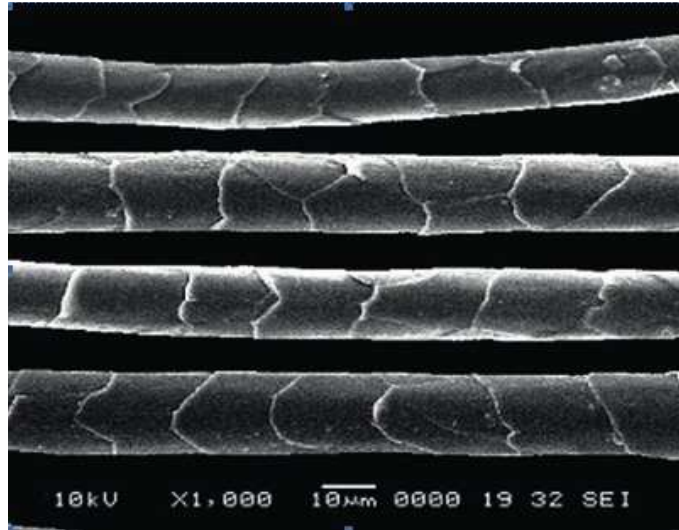


Figure B.19 — Orderly ring-shaped scales with thin and smooth edges, scale frequency is low

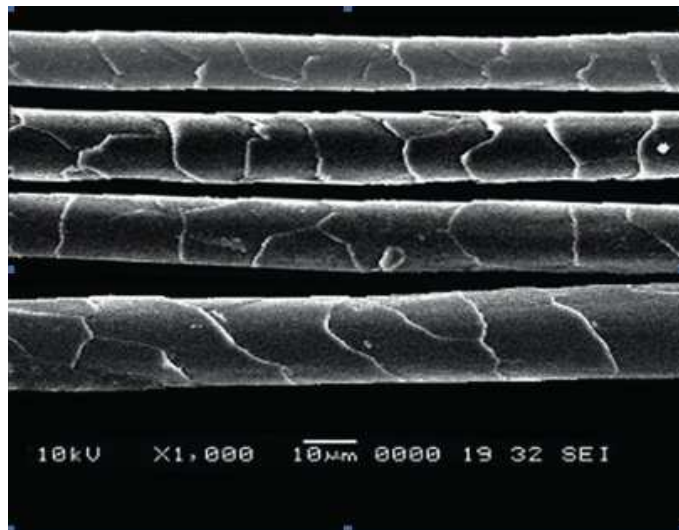
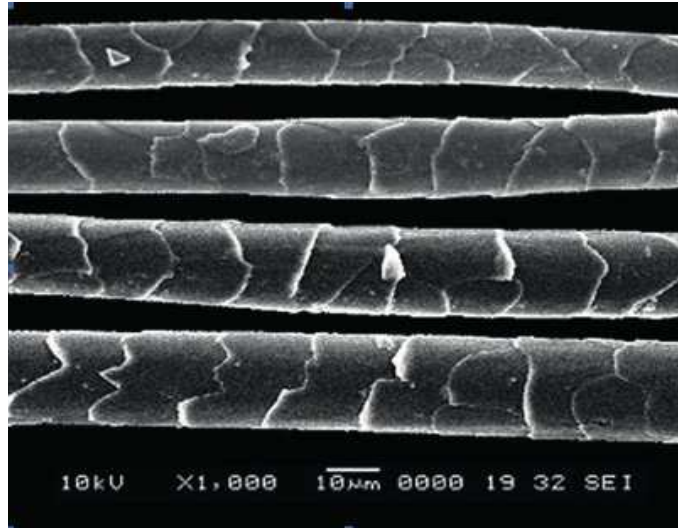
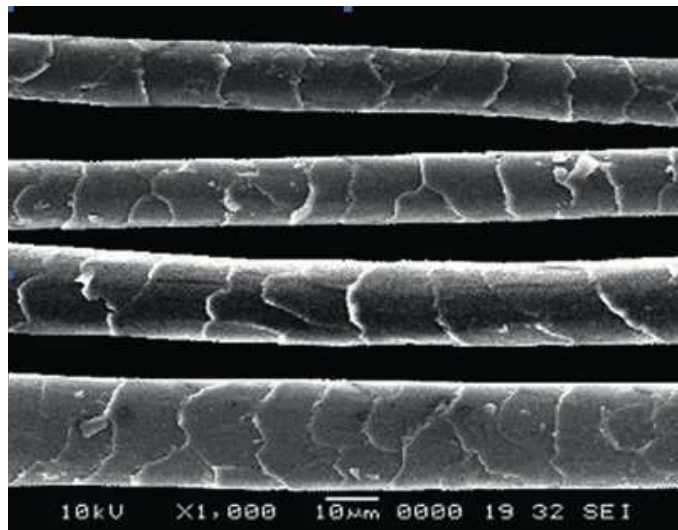


Figure B.20 — Scale edges are somewhat unsmooth





**Figure B.21 — High scale frequency with untidy scale edges**



**Figure B.22 — High scale frequency and untidy scale edges, fibre surfaces are not smooth**

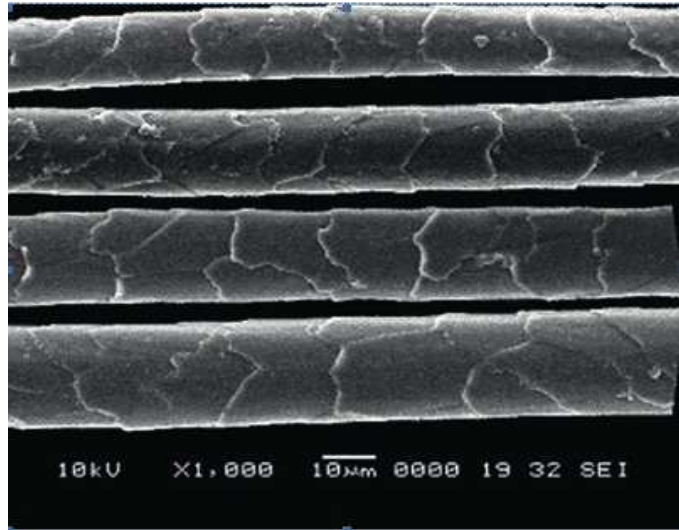


Figure B.23 — Blurry scales with untidy scale edges

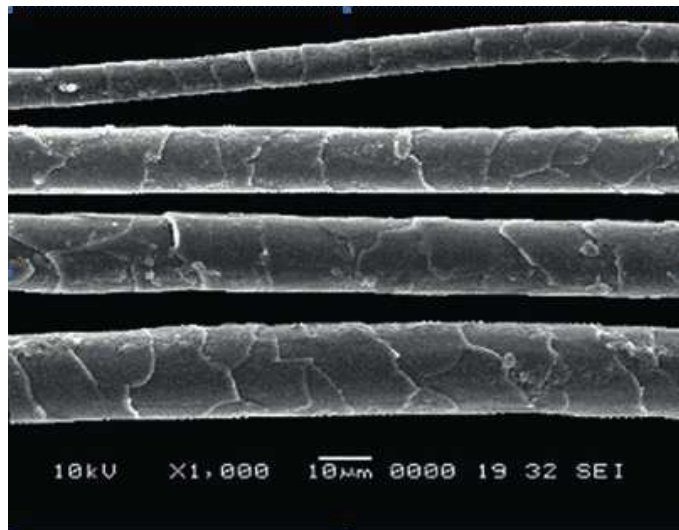


Figure B.24 — Blurry scales with untidy scale edges, fibre surfaces are not smooth

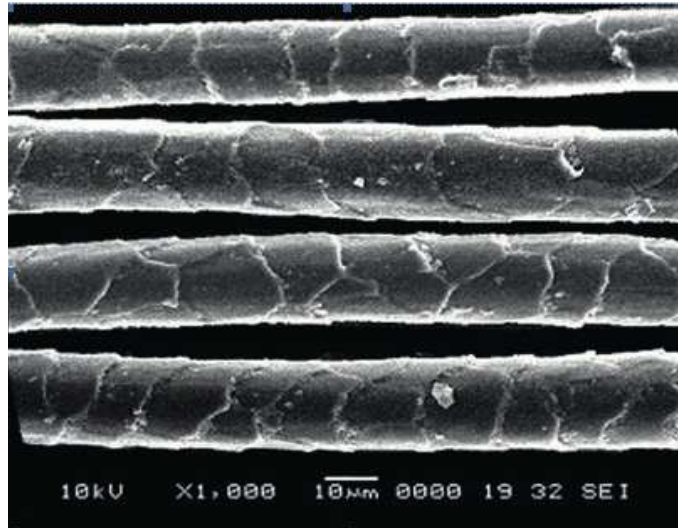


Figure B.25 — Blurry and unclear scales with untidy and thicker scale edges

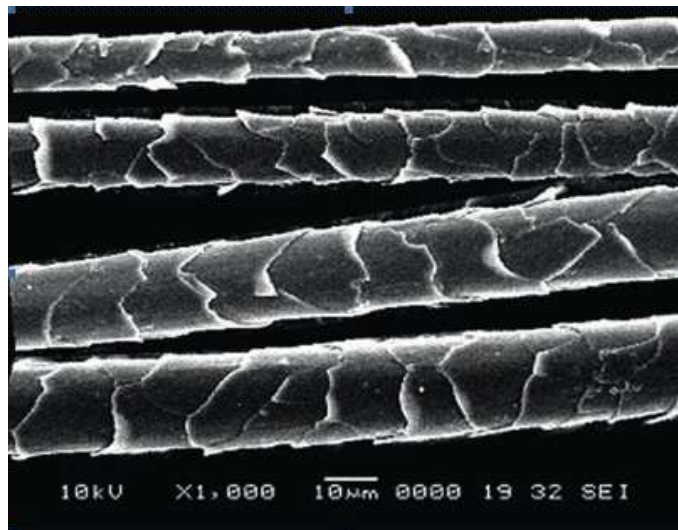


Figure B.26 — High scale frequency, disorder and bent scale edges

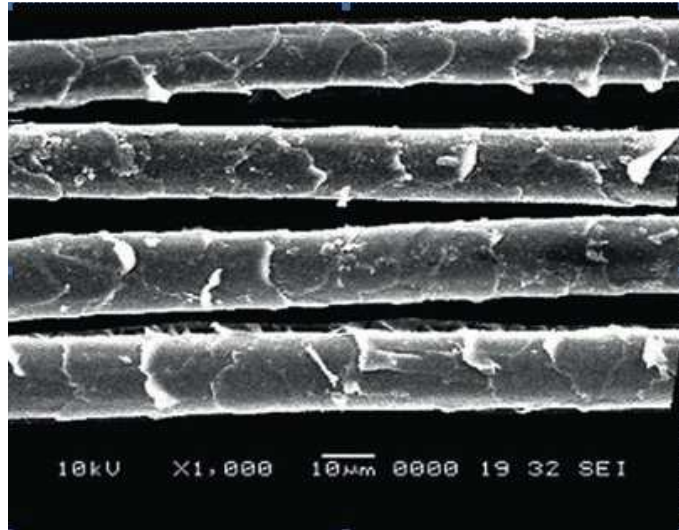


Figure B.27 — Damaged, stripped, and warped scales

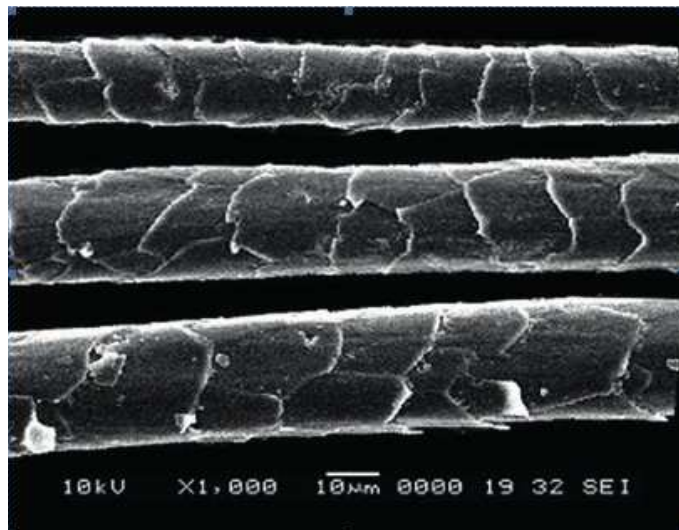


Figure B.28 — Rough scale surface and indistinctive ring-shaped scales with disorder scale margins, scales are block-shaped on the whole

### B.3 Cashmere from Iran and Afghanistan

See [Figures B.29](#) to [B.40](#).

Cashmeres from Iran and Afghanistan are basically all pigmented cashmeres with various colours. Scale morphologies of cashmeres from such origins are better in comparison with those of cashmeres from Mongolia. Cashmere from Iran and Afghanistan can be determined from the aspect of the mean fibre diameter for the entire testing lot of materials. This is due to the fact that mean fibre diameters of brown and grey cashmere from China are smaller than those of white cashmere with mean fibre diameter lower than 15  $\mu\text{m}$ . The mean fibre diameter of cashmere from Iran and Afghanistan is higher than 16  $\mu\text{m}$ . However, if these cashmeres are blended into cashmere from China, it is not easy to distinguish them.

The mean scale height of cashmere from Iran and Afghanistan is 0,43  $\mu\text{m}$  and the mean scale frequency is 62,6 scales/mm. As for the cashmere from Mongolia, no further classification according to fibre scale

morphology types is made because the scale morphologies are relatively consistent. Micrographs are shown according to the fibre morphologies from good to bad.

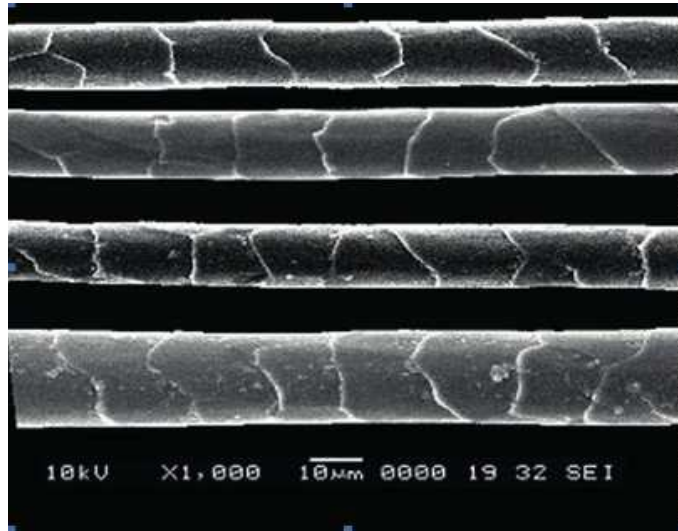


Figure B.29 — Regular ring-shaped scales with smooth and thin edges, scale frequency is low

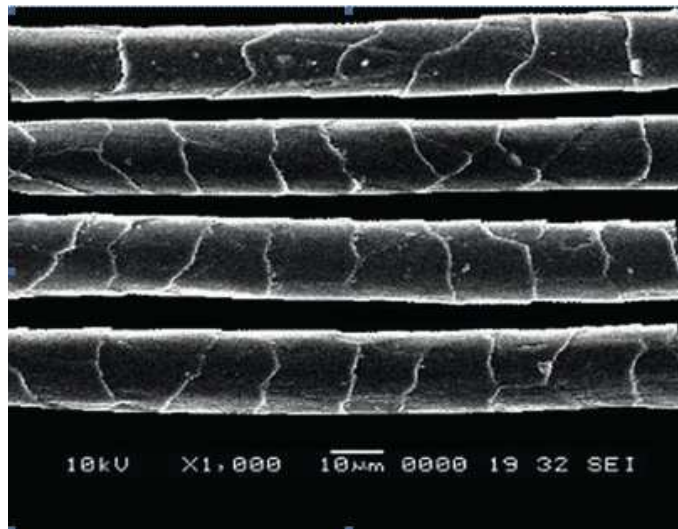
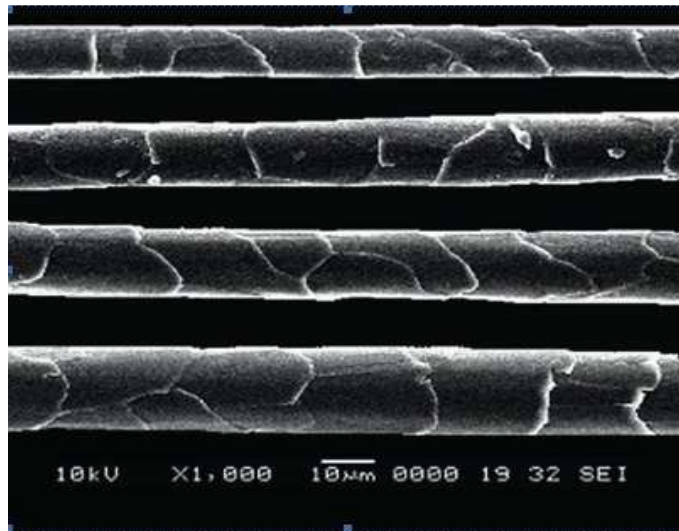
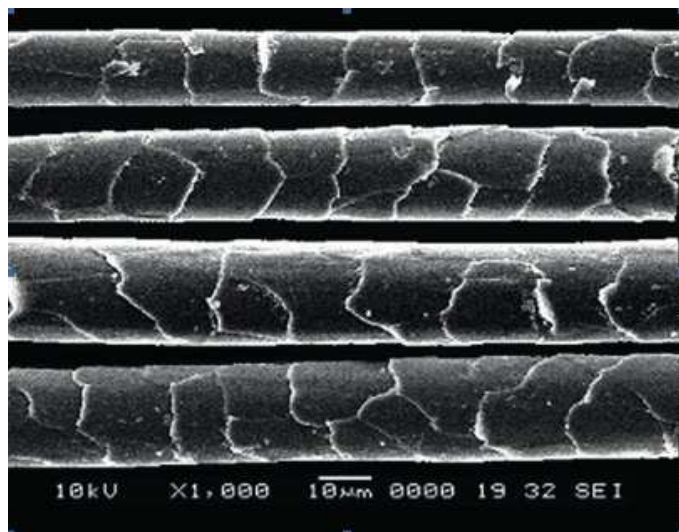


Figure B.30 — Regular ring-shaped scales with smooth edges





**Figure B.31 — Slightly irregular scales with slightly low scale frequency**



**Figure B.32 — Slightly unsmooth scale surfaces with relatively high scale frequency**

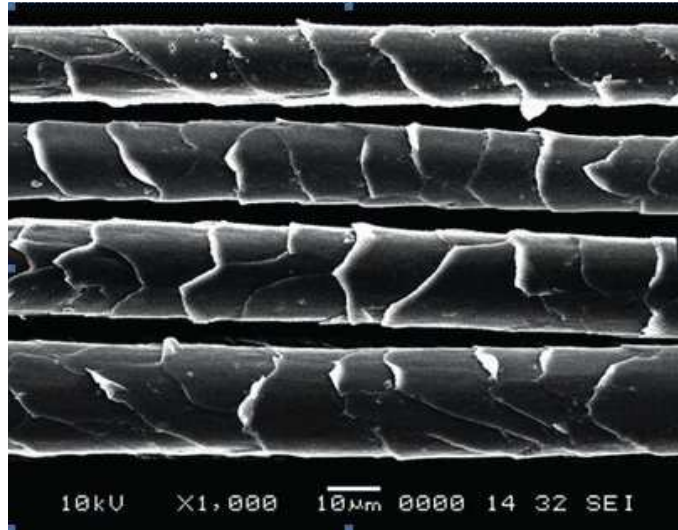


Figure B.33 — Slightly warping irregular scale edges

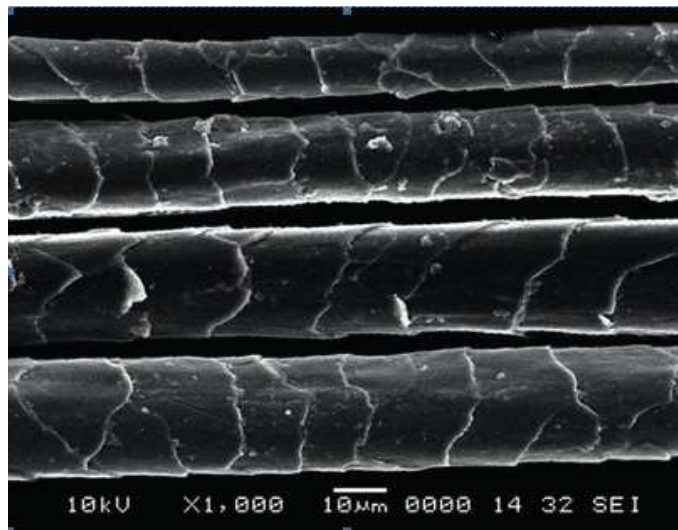


Figure B.34 — Unsmooth scale surface with thick scale edges

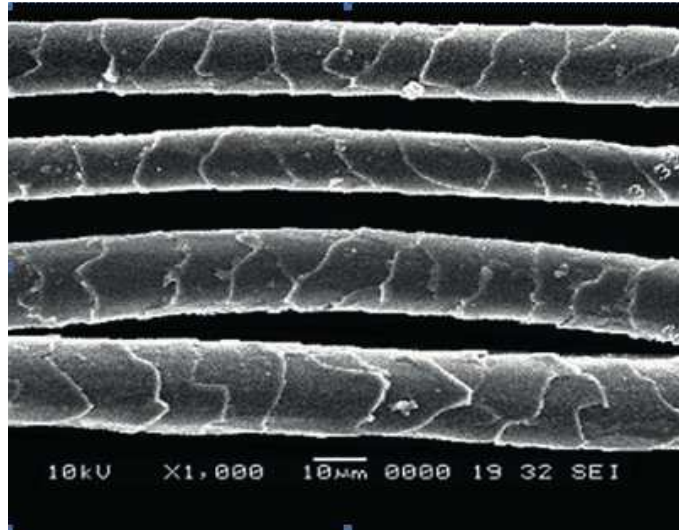


Figure B.35 — High scale frequency and slightly unsmooth scale surface

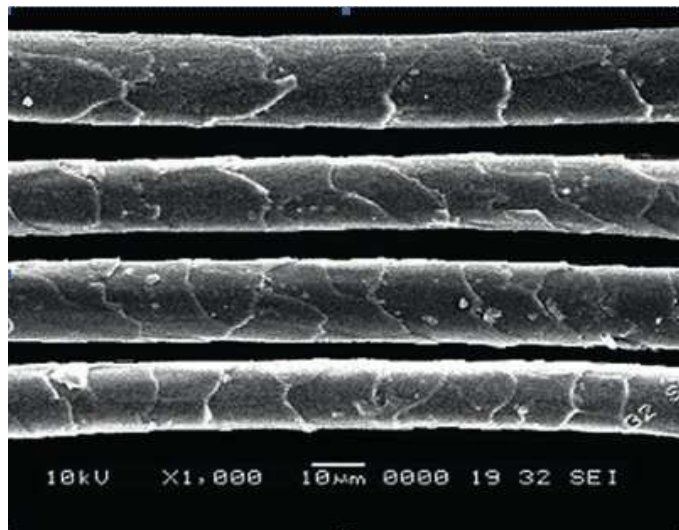
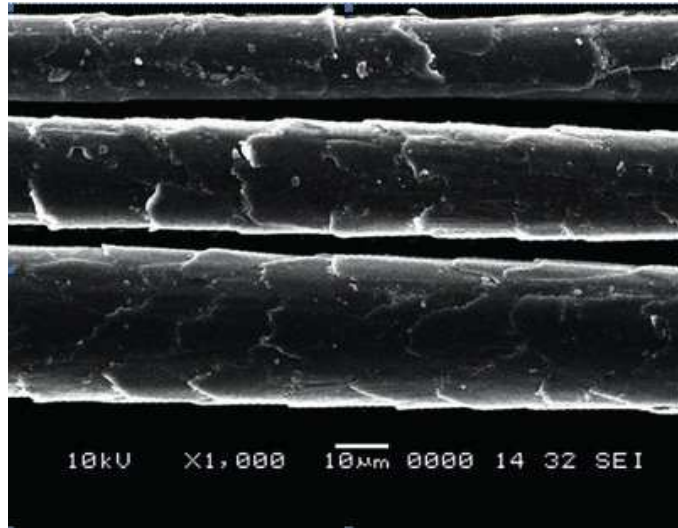
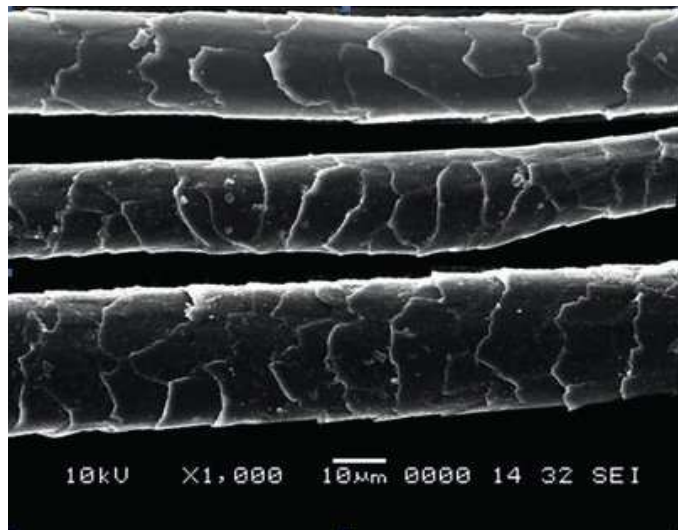


Figure B.36 — slightly irregularly-arranged scale





**Figure B.37 — Blurry and unclear scales**



**Figure B.38 — Serrated scale edges with high scale frequency**

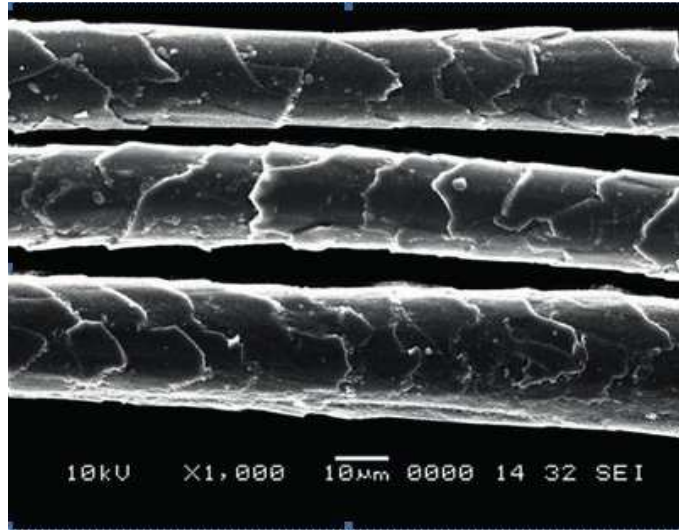


Figure B.39 — Blurry scales with unsmooth and irregular scale edges

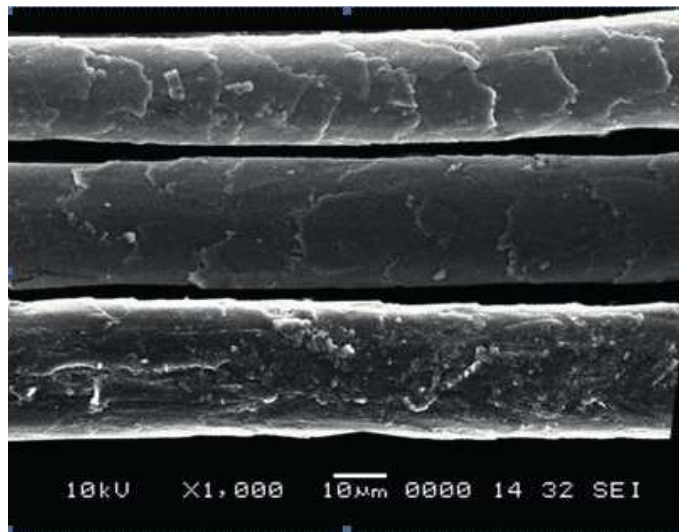


Figure B.40 — Fibres with shed scales

## B.4 Sheep's wool and modified sheep's wool

### B.4.1 Chinese native fine sheep's wool

Heterogeneous sheep's wools taken from Chinese native sheep without crossbreeding deviates largely in fibre diameter; coarse wool and fine wool can be separated using cashmere dehairing equipment and mean fibre diameter of the fine wool, thus sorted, is between 19  $\mu\text{m}$  and 15  $\mu\text{m}$ ; additional dehairing leads to a lower mean fibre diameter of this type of fine sheep's wool. This type of wool is often used in cashmere adulteration due to its easy access and its similarities in fibre morphology with cashmere.

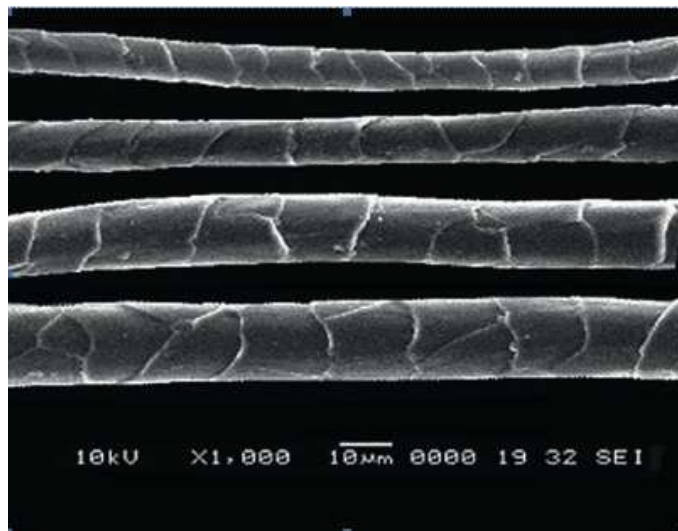
The mean scale height of commonly used native fine sheep's wool is between 0,6  $\mu\text{m}$  and 0,7  $\mu\text{m}$ , and mean scale frequency is between 59 scales/mm and 65 scales/mm.

Chinese native sheep's wool has a predominant feature of higher fibre evenness in its axial direction and lower scale frequency compared with Australian wool which are similar with features of cashmere, but it is still distinguishable by experienced fibre analysts. Firstly, judge, as a whole, whether there is Chinese native fine wool blended into the sample. Secondly, when identifying fine wool fibres showing

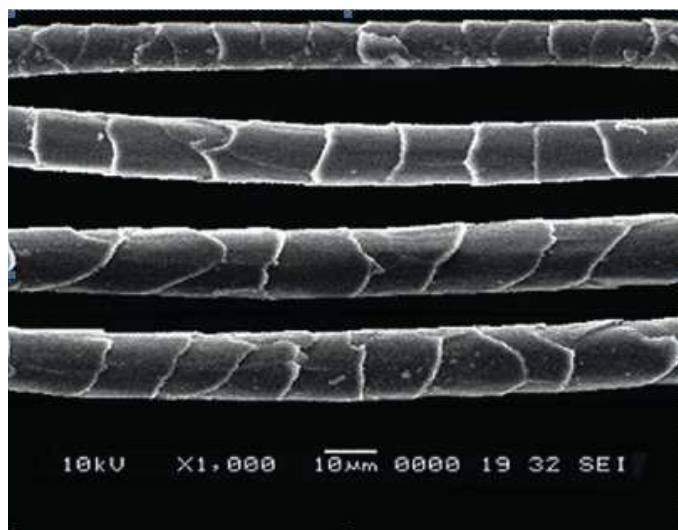
similar scale morphology as those in Group I, distinguish them by the aspects of fibre lustre and scale height if a Light Microscope is used, or distinguish them by the aspects of scale surface smoothness and scale height if a scanning electron microscope is used. For fine wool fibres with the same scale morphologies as shown in the following other groups, the misidentification rate is comparatively low due to the existence of more different judging elements.

Five groups are classified according to fibre scale morphologies from good to bad.

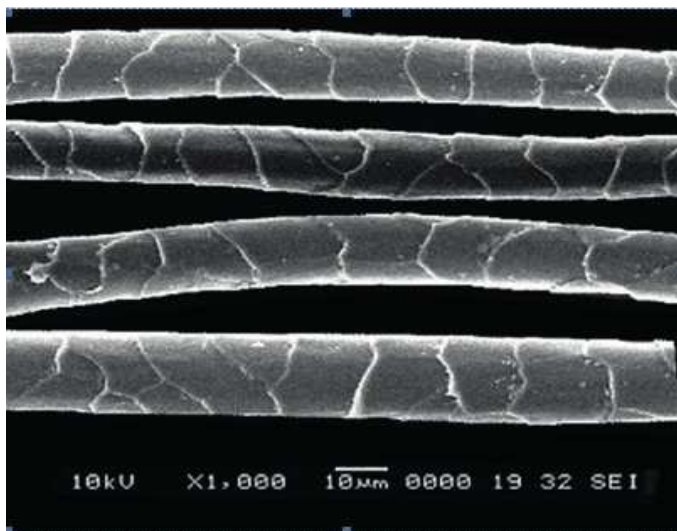
Group I: See [Figures B.41](#) to [B.43](#). Fibre morphologies of native fine sheep's wool in Group I are basically the same as those of cashmere, that is fibres show high diameter evenness in the axial direction with regular ring-shaped scales, scales envelop the fibre shaft regularly, but fibre lustre is a little worse, and the scale height is higher than that of cashmere. The diameter of wools with such scale morphologies is basically below 15  $\mu\text{m}$ .



**Figure B.41 — Ring-shaped scales encircle fibre shafts**

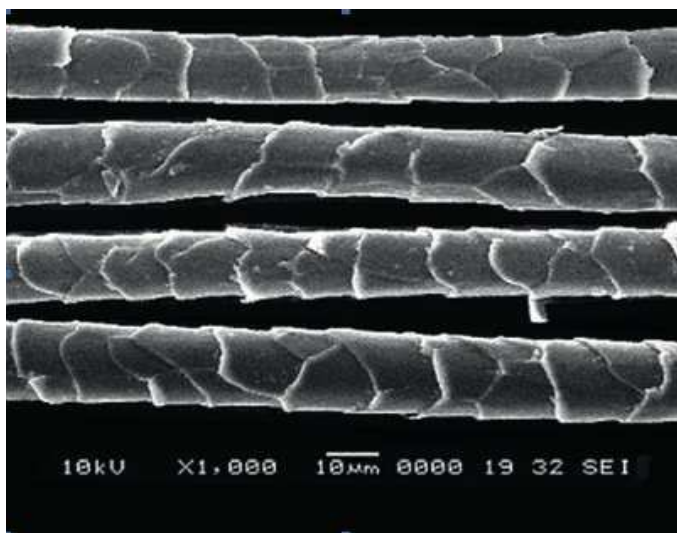


**Figure B.42 — Unsmooth fibre surfaces**

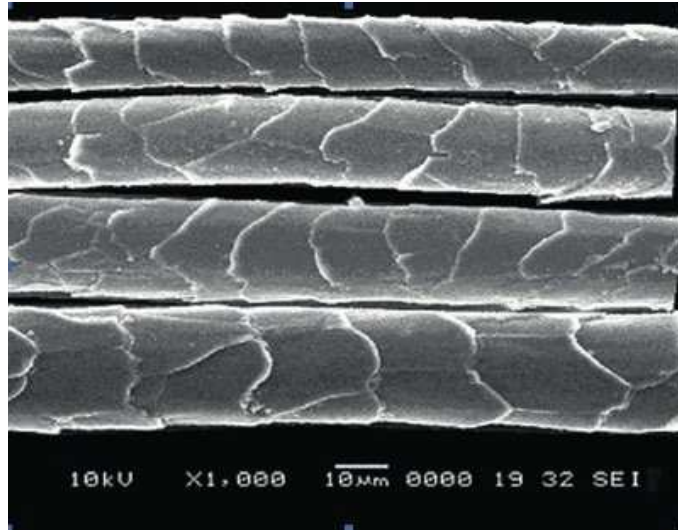


**Figure B.43 — Bad fibre lustre**

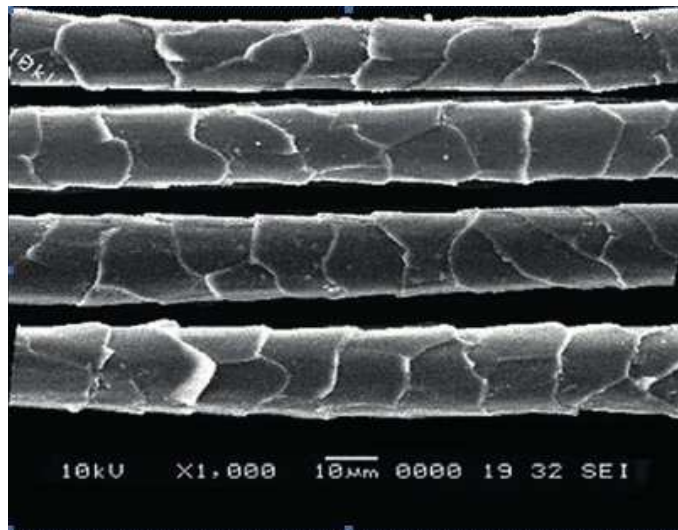
Group II: See [Figures B.44](#) to [B.46](#). Scales display irregular ring-shaped patterns. The fibre diameter is comparatively even in its axial direction. Wool fibres show very obvious differences from cashmere in the aspects such as rougher scale surfaces, thicker scale heights, and higher scale frequency and larger warping angles of scale edges.



**Figure B.44 — Thicker scale edges warping outside**



**Figure B.45 — Unsmooth and irregular fibre surface**



**Figure B.46 — Higher scale frequency with thicker scale edges**

Group III: See [Figures B.47](#) to [B.49](#). Fibres show higher evenness in the axial direction than the same diameter Australian wool. Fibres exhibit worse lustre. Scale edges have larger warping angles. Fibres show lower scale height, but higher scale frequency than fibres in Group II.



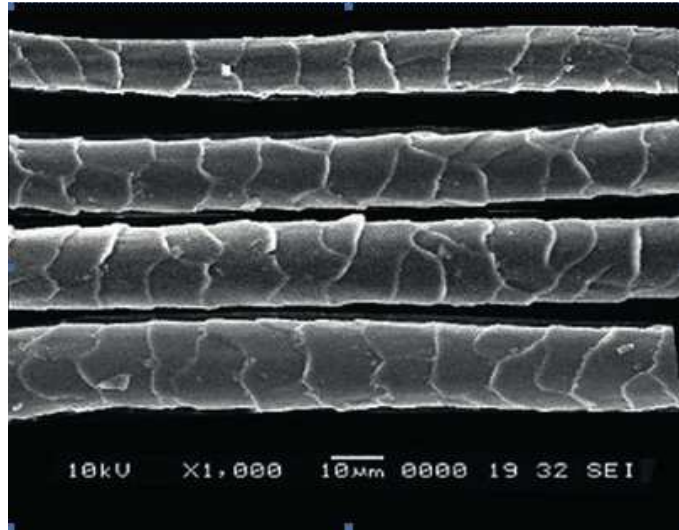


Figure B.47 — High scale frequency with thicker scale edges

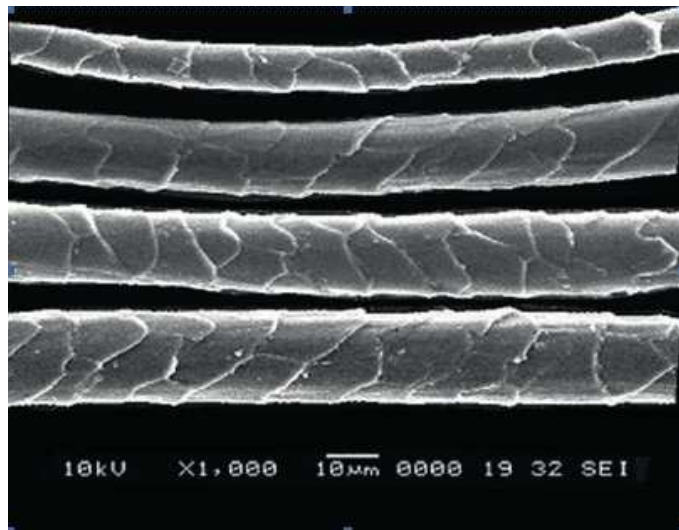
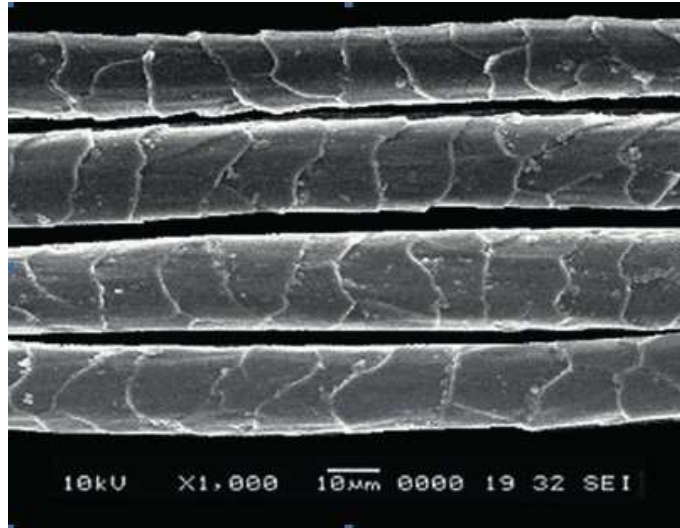
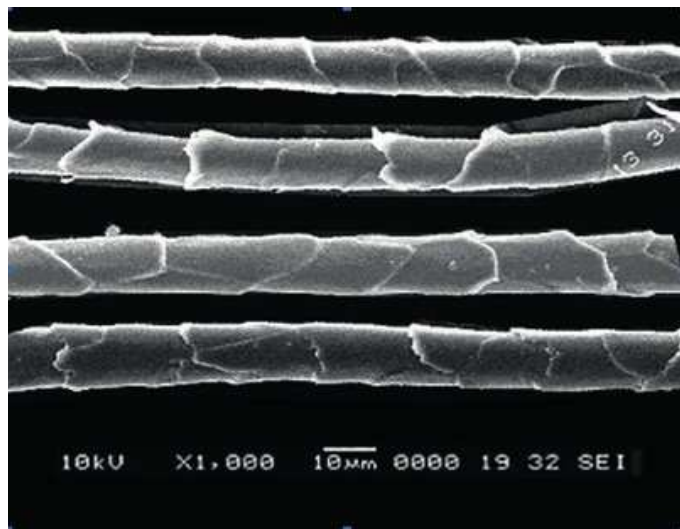


Figure B.48 — High scale frequency with irregular scales



**Figure B.49 — Rough scale surfaces**

Group IV: See [Figures B.50](#) to [B.53](#). Fibres show higher evenness in the axial direction than the same diameter Australian wool. Finer wools (with diameters below 13  $\mu\text{m}$ ) have low scale frequency with irregular scales. Coarser wools show tile or ramous-shaped patterns with rough scale surfaces and bad lustre, warping angles of scales are larger, and partial scales shed from the fibre shaft.



**Figure B.50 — Scale frequency is low, but scales are irregularly arranged**

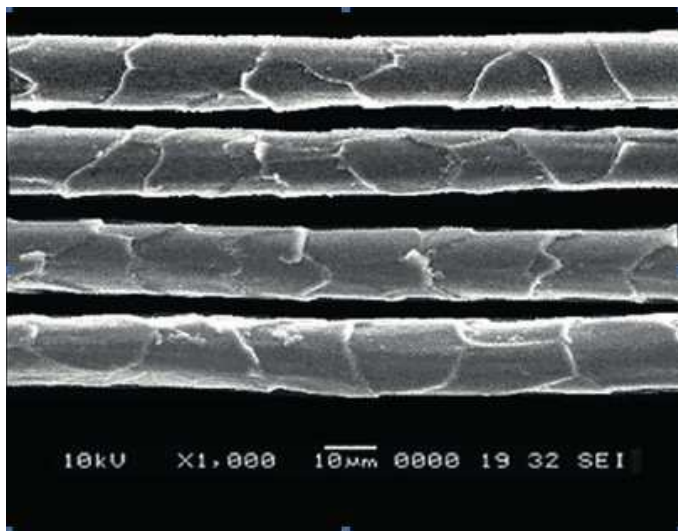


Figure B.51 — Untidy scale edges

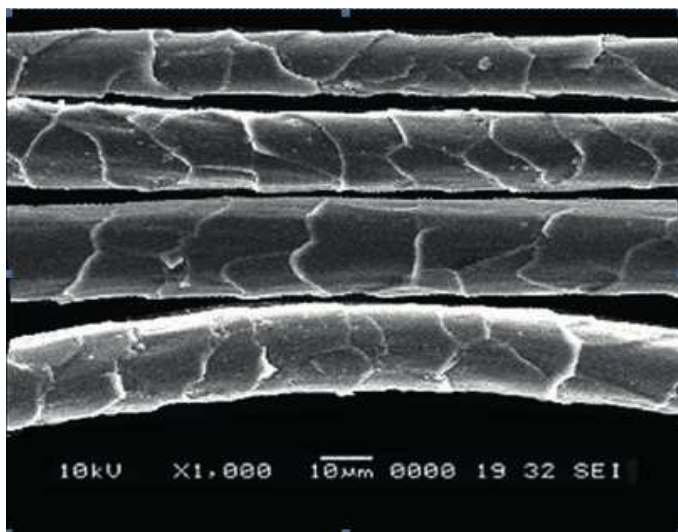
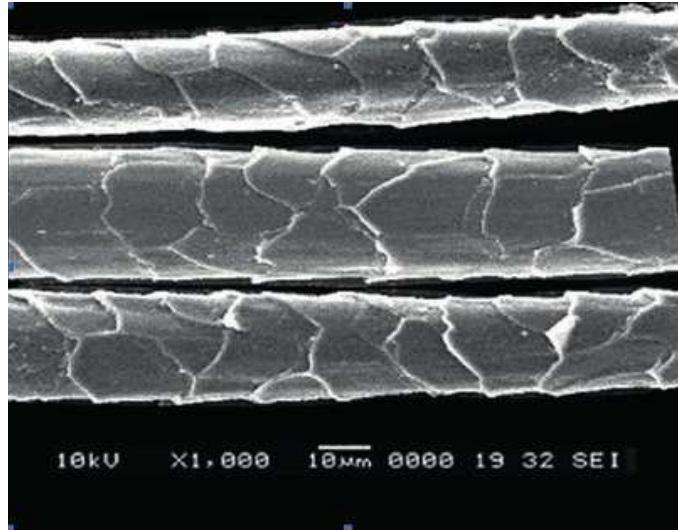


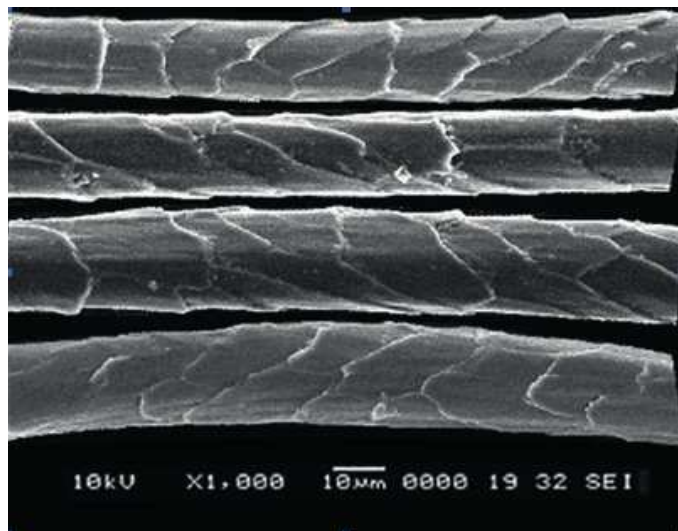
Figure B.52 — Irregular scales





**Figure B.53 — Thick scales and large scale frequencies**

Group V: See [Figures B.54 to B.60](#). Fibres show higher diameter evenness in the axial direction than the same diameter Australian wool. Scales show a large variation on the tile or ramous shaped patterns with large scale height. Fibre surfaces are rough with bad lustre. Striations and furrows are obvious and partial scales shed from the fibre shaft.



**Figure B.54 — Rough surfaces with irregular scales**

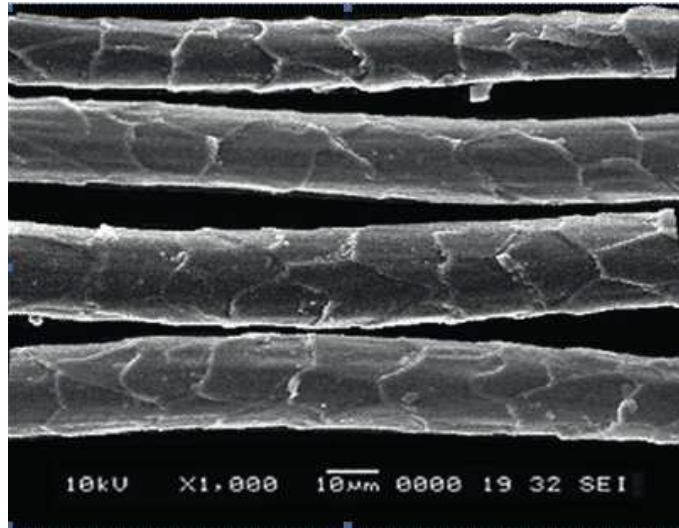


Figure B.55 — Thick scales with unclear scale edges

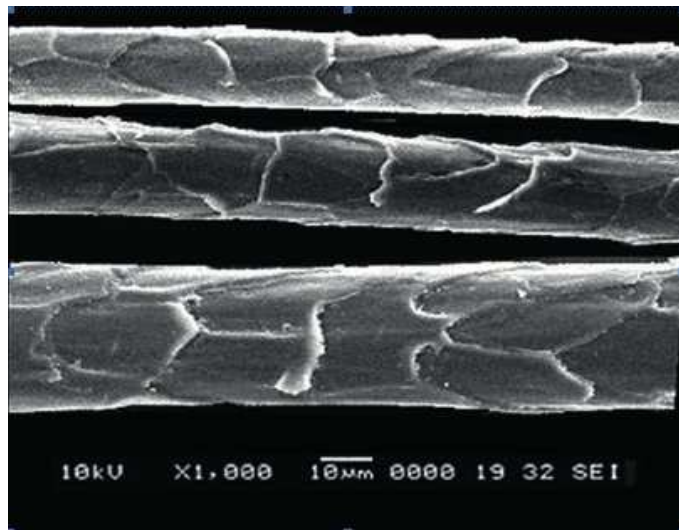


Figure B.56 — Very thick scales, rough surface with furrows

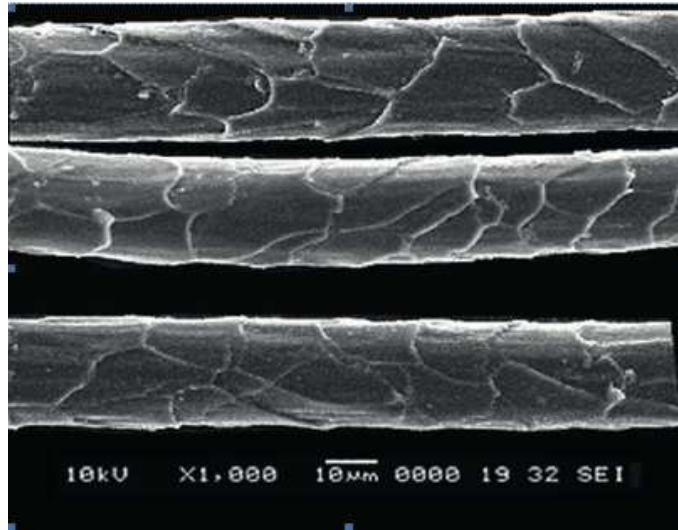


Figure B.57 — Disorderly scales, rough surface with furrows

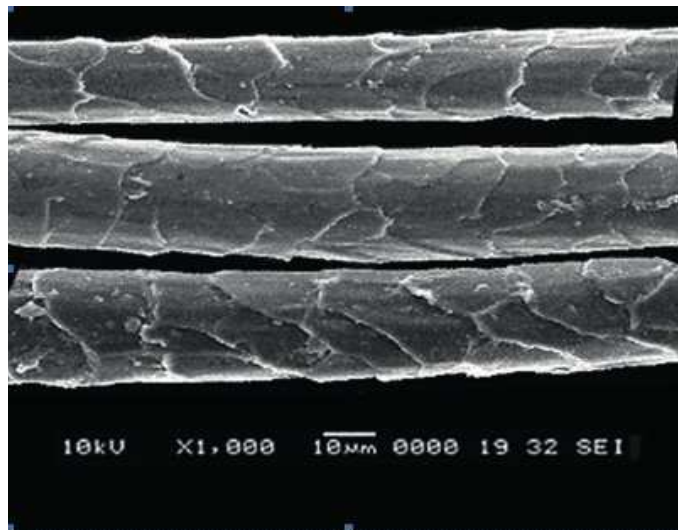


Figure B.58 — Disorderly scales, rough surfaces

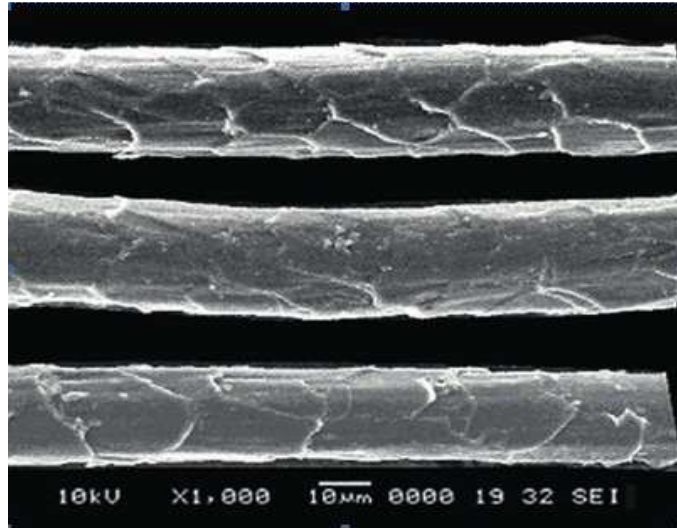


Figure B.59 — Blurry scales

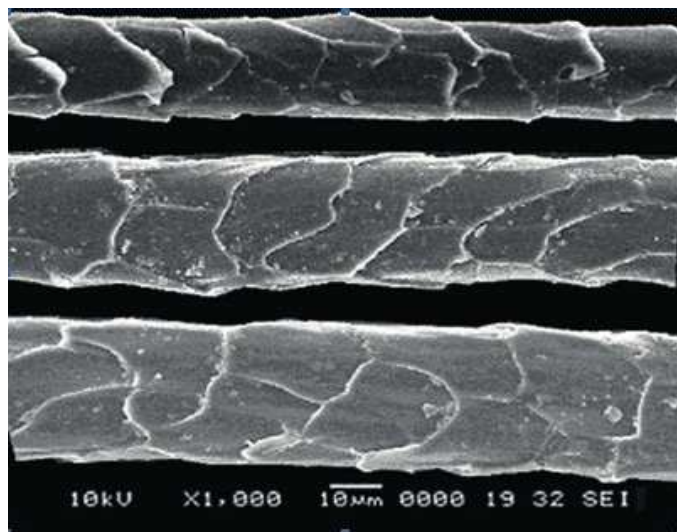
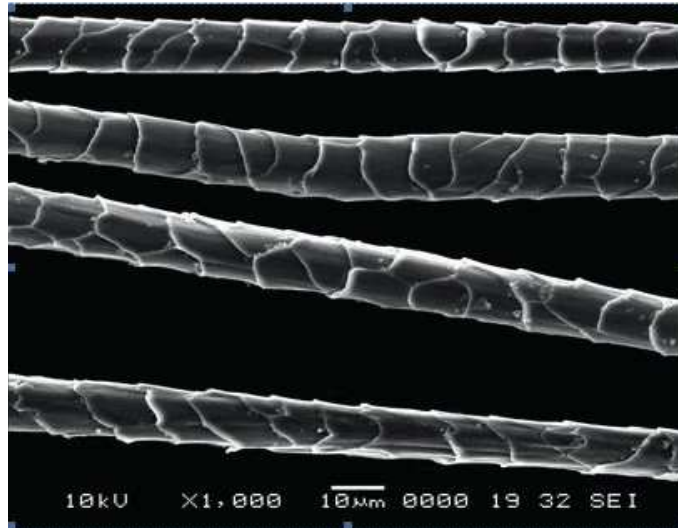


Figure B.60 — Thick scales, high scale frequency, rough fibre surface

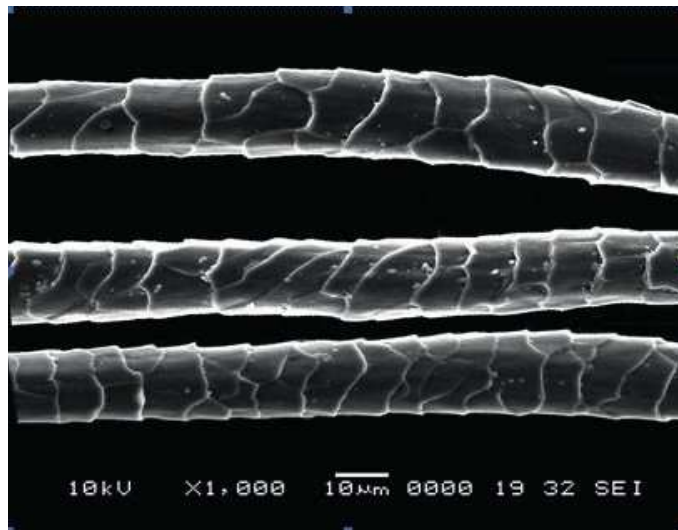
#### B.4.2 Merino wool from Australia

See [Figures B.61](#) to [B.63](#). Merino wool from Australia with a fibre diameter less than 18,5  $\mu\text{m}$  has a comparatively high yield. Such wools are often blended with cashmere to produce worsted products taking advantages of its large fibre length, low diameter, and low CV % of mean diameter. Typical characteristics of such wools are high fibre scale frequency and low fibre evenness in the axial direction which makes it easier to distinguish them from other wools if blended.

The mean scale height of commonly used superfine Merino wools is 0,60  $\mu\text{m}$  to 0,65  $\mu\text{m}$ . The mean scale frequency varies from 72 scales/mm to 79 scales/mm. There is little difference between the scale morphologies for fine and coarse wools.



**Figure B.61 — Fine wool from Australia**



**Figure B.62 — Medium wool from Australia**



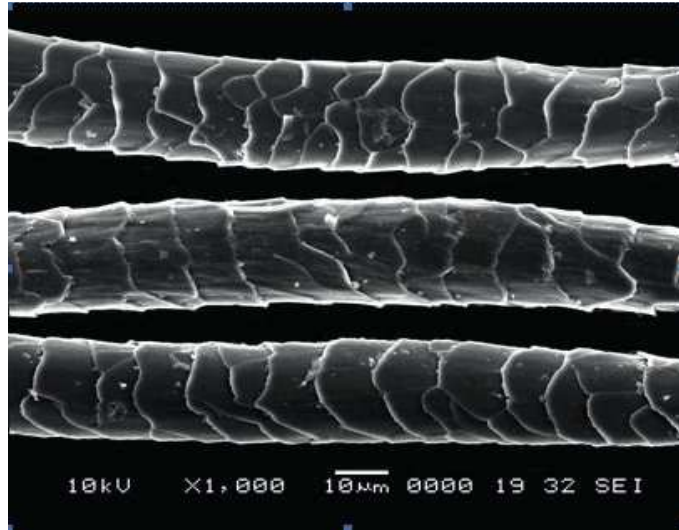


Figure B.63 — Coarse wool from Australia

### B.4.3 Modified wool

See [Figures B.64 to B.66](#).

Commonly used *modified wools* include shrink-proof wool, mercerized wool, and stretched wool.

Shrink-proof treatment includes additive (polymer) treatment and oxidative treatment; the latter one is the most commonly used. The following micrograph shows typical scale morphologies of shrink-proof wool and mercerized wool. The two types of scale morphologies simultaneously exist in whole batches of both shrink-proof wools and mercerized wools.

Stretched wools have better lustre because scale patterns are not changed during the stretching process, but the scale surface becomes smoother, resulting in a weaker diffuse reflection and a stronger reflection in the same direction. Meanwhile, the stretched wool shows a similar lustre to that of silk due to the changes on its cross section. This is a very important phenomenon in judging whether there is stretched wool blended into cashmere. Stretched wool also has the following characteristics: low fibre evenness in its axial direction, large difference on the distances of two adjacent scales, and some scales shed from fibre shaft.

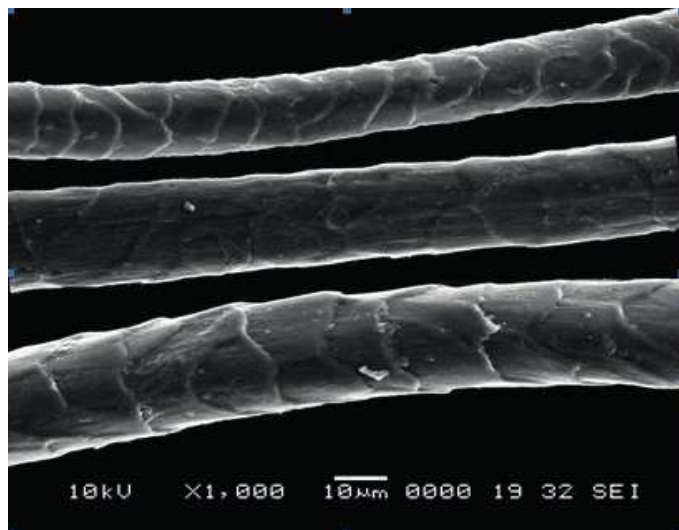


Figure B.64 — Shrink resistant wool



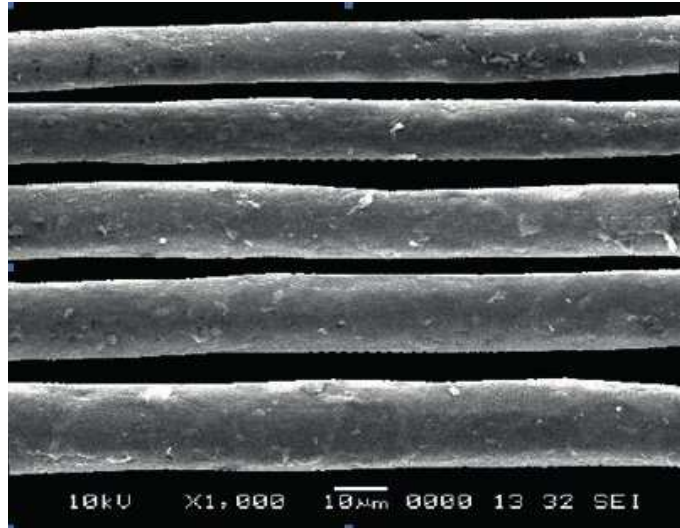


Figure B.65 — Mercerized wool

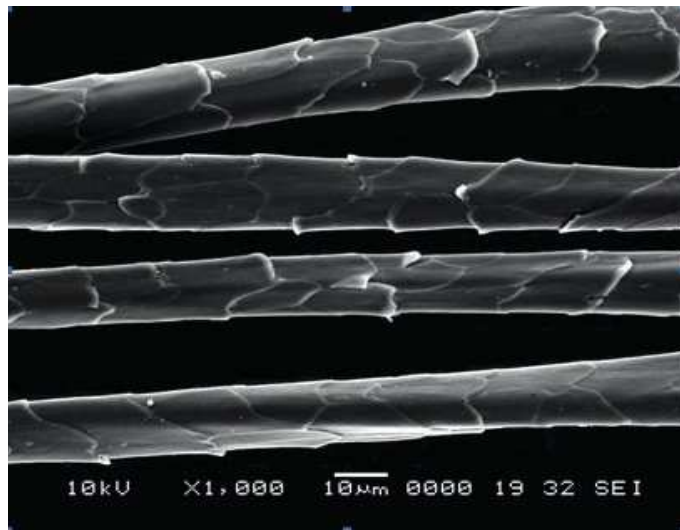


Figure B.66 — Stretched wool

## B.5 Other types of speciality animal fibres

### B.5.1 Camel hair

See [Figures B.67](#) to [B.69](#). Finer camel hairs show slantwise striation or ring-shaped patterns. Some fine fibres have scale patterns resembling those of cashmere while coarser camel fibres show blurry and disorderly scales. Scales of camel hair are thin and fibre diameters are even in the axial direction.

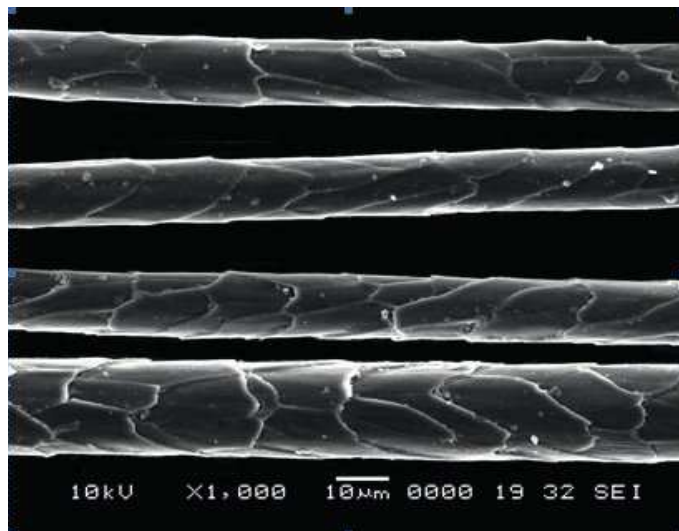


Figure B.67 — Typical camel hair

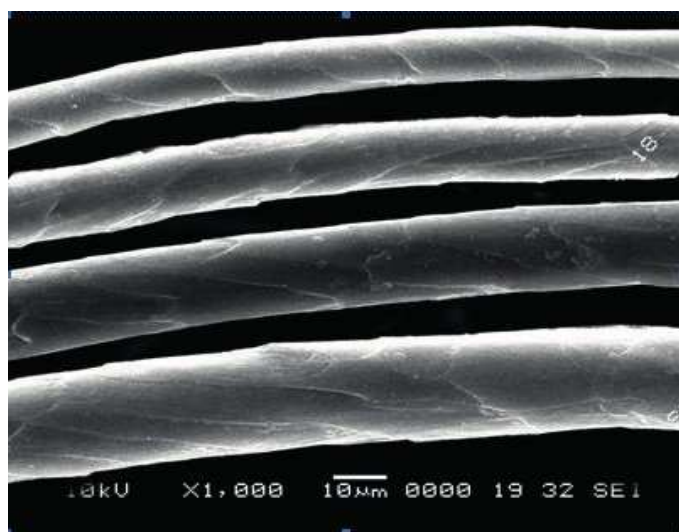


Figure B.68 — Blurry scales

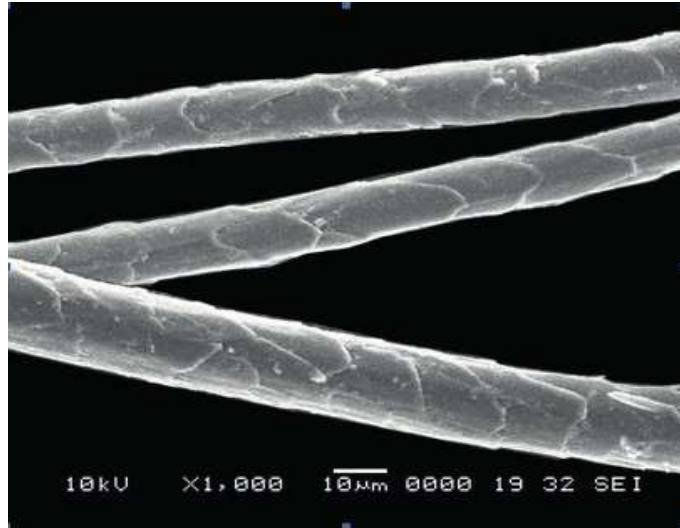


Figure B.69 — Scales resemble to those of cashmere fibres

### B.5.2 Yak

See [Figures B.70](#) to [B.72](#). Scales encircle the fibre shaft tightly with irregular ring-shaped patterns, scales are thin, and a large proportion of yak fibres have a high scale frequency with high diameter evenness in the fibre's axial direction.

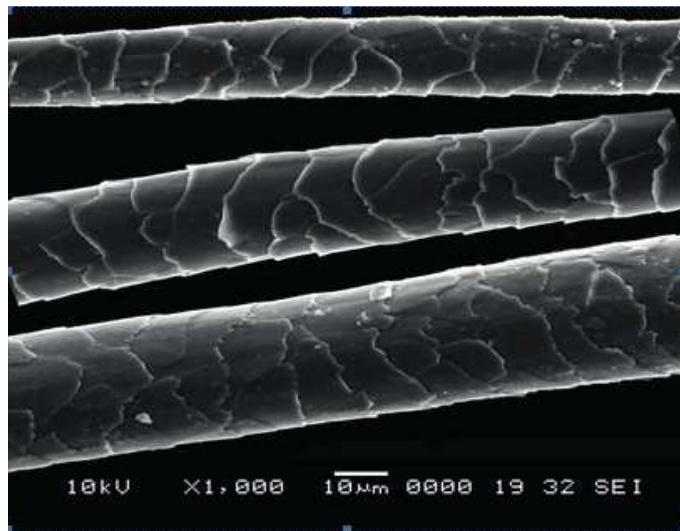


Figure B.70 — Typical yak

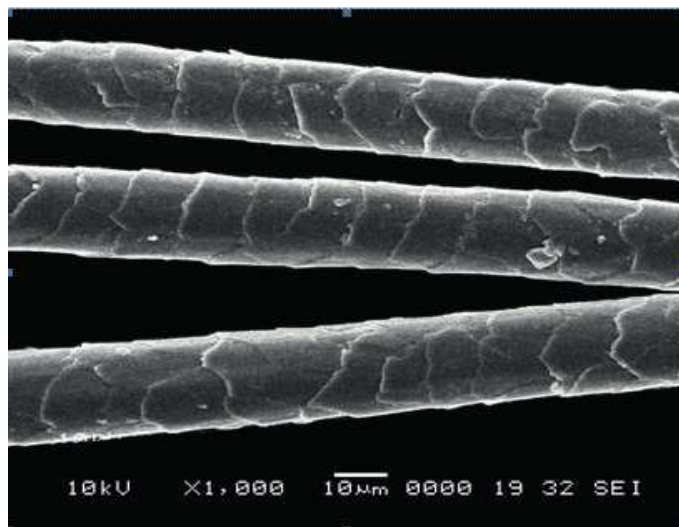


Figure B.71 — Scales resemble to those of cashmere fibres

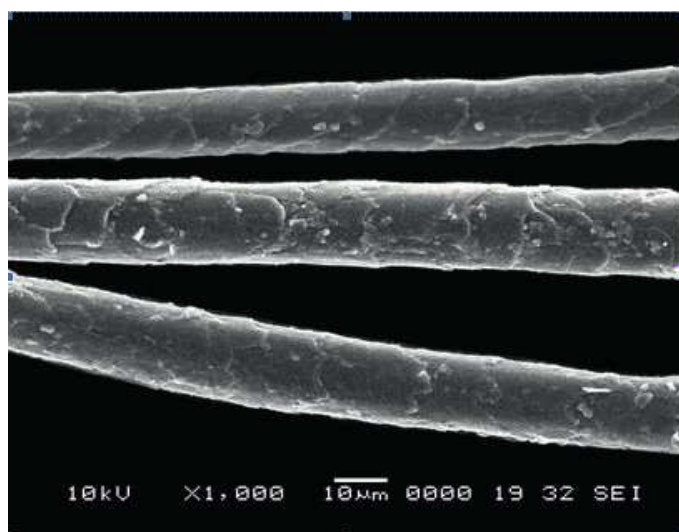
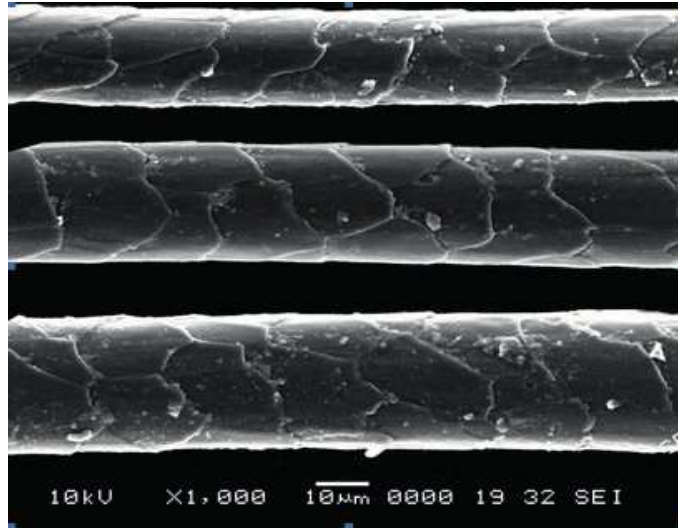


Figure B.72 — Blurry scales

### B.5.3 Mohair

See [Figure B.73](#).

Scales of mohair overlap flatly and regularly on the fibre shaft with tile shapes. Finer mohair shows similar scale patterns to those of cashmere. Mohair exhibits the following features: even diameter, straight fibre shaft, bright lustre, and smooth surface.

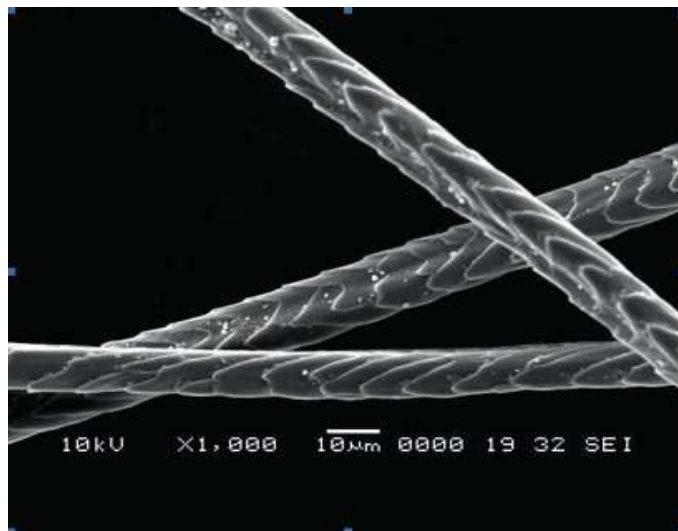


**Figure B.73 — Mohair**

#### **B.5.4 Rabbit hair**

See [Figure B.74](#).

Rabbit hair fibre shows a unique fibre morphology so it is easy to distinguish from others.



**Figure B.74 — Rabbit hair**

#### **B.5.5 Alpaca wool**

See [Figure B.75](#).

Alpaca fibre shows a high scale frequency with less clear and ripple-crenate edges.

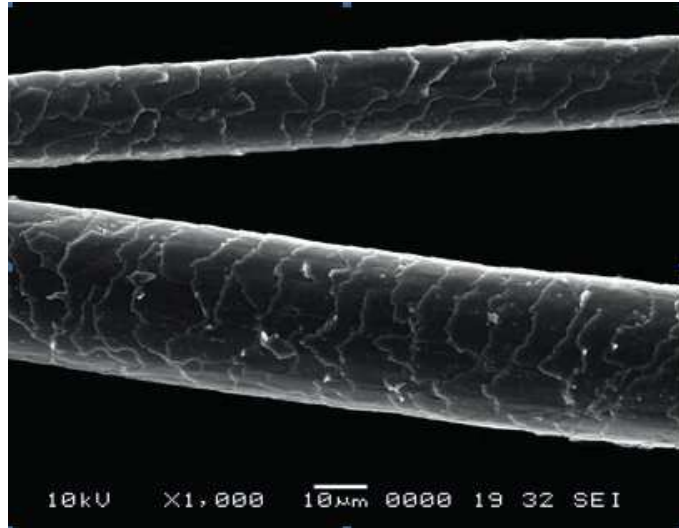


Figure B.75 — Alpaca wool

#### B.5.6 Goat coarse hair (diameter $\geq 30 \mu\text{m}$ )

See [Figure B.76](#).

Scales are thin and clear with a high scale frequency. Scales display ripple-crenate margins.



Figure B.76 — Goat coarse hair



## Annex C (normative)

### Density of common animal fibres

Table C.1 — Density of common animal fibres

Fibre type	Density g/cm <sup>3</sup>
Wool	1,31
Cashmere	1,31
Camel wool	1,31
Yak wool	1,31
Mohair	1,31
Alpaca wool	1,30
Rabbit hair	1,15

## Bibliography

- [1] IWTO-58-00, *Scanning electron microscopic analysis of speciality fibres and sheep's wool and their blends*



