**Milk and milk products — Determination
of milk fat purity by gas chromatographic
analysis of triglycerides (Reference
method)**

*Lait et produits laitiers — Détermination de la pureté des matières
grasses laitières par analyse chromatographique en phase gazeuse des
triglycérides (Méthode de référence)*



PDF disclaimer

This PDF file may contain embedded typefaces. In accordance with Adobe's licensing policy, this file may be printed or viewed but shall not be edited unless the typefaces which are embedded are licensed to and installed on the computer performing the editing. In downloading this file, parties accept therein the responsibility of not infringing Adobe's licensing policy. Neither the ISO Central Secretariat nor the IDF accepts any liability in this area.

Adobe is a trademark of Adobe Systems Incorporated.

Details of the software products used to create this PDF file can be found in the General Info relative to the file; the PDF-creation parameters were optimized for printing. Every care has been taken to ensure that the file is suitable for use by ISO member bodies and IDF national committees. In the unlikely event that a problem relating to it is found, please inform the ISO Central Secretariat at the address given below.



COPYRIGHT PROTECTED DOCUMENT

© ISO and IDF 2010

All rights reserved. Unless otherwise specified, no part of this publication may be reproduced or utilized in any form or by any means, electronic or mechanical, including photocopying and microfilm, without permission in writing from either ISO or IDF at the respective address below.

ISO copyright office
Case postale 56 • CH-1211 Geneva 20
Tel. + 41 22 749 01 11
Fax + 41 22 749 09 47
E-mail copyright@iso.org
Web www.iso.org

International Dairy Federation
Diamant Building • Boulevard Auguste Reyers 80 • B-1030 Brussels
Tel. + 32 2 733 98 88
Fax + 32 2 733 04 13
E-mail info@fil-idf.org
Web www.fil-idf.org

Published in Switzerland

Contents

Page

Foreword	iv
1 Scope	1
2 Normative references	2
3 Terms and definitions	2
4 Principle	2
5 Reagents	2
6 Apparatus	3
7 Sampling	4
8 Procedure	4
8.1 Preparation of test samples	4
8.2 Preparation of fat sample solution	5
8.3 Chromatographic triglyceride determination	5
9 Integration, evaluation and control of the analytical performance	8
10 Calculation and expression of results	9
10.1 Triglyceride composition	9
10.2 S-values	10
10.3 Detection of foreign fat	10
11 Precision	11
11.1 Interlaboratory test	11
11.2 Repeatability	11
11.3 Reproducibility	12
12 Test report	12
Annex A (normative) Preparation of the packed column	13
Annex B (informative) Quantification of the foreign fat content	17
Annex C (informative) Uncertainty of measurement	19
Annex D (informative) Interlaboratory test	20
Bibliography	22

Foreword

ISO (the International Organization for Standardization) is a worldwide federation of national standards bodies (ISO member bodies). The work of preparing International Standards is normally carried out through ISO technical committees. Each member body interested in a subject for which a technical committee has been established has the right to be represented on that committee. International organizations, governmental and non-governmental, in liaison with ISO, also take part in the work. ISO collaborates closely with the International Electrotechnical Commission (IEC) on all matters of electrotechnical standardization.

International Standards are drafted in accordance with the rules given in the ISO/IEC Directives, Part 2.

The main task of technical committees is to prepare International Standards. Draft International Standards adopted by the technical committees are circulated to the member bodies for voting. Publication as an International Standard requires approval by at least 75 % of the member bodies casting a vote.

Attention is drawn to the possibility that some of the elements of this document may be the subject of patent rights. ISO shall not be held responsible for identifying any or all such patent rights.

ISO 17678|IDF 202 was prepared by Technical Committee ISO/TC 34, *Food products*, Subcommittee SC 5, *Milk and milk products*, and the International Dairy Federation (IDF). It is being published jointly by ISO and IDF.

Foreword

IDF (the International Dairy Federation) is a non-profit organization representing the dairy sector worldwide. IDF membership comprises National Committees in every member country as well as regional dairy associations having signed a formal agreement on cooperation with IDF. All members of IDF have the right to be represented on the IDF Standing Committees carrying out the technical work. IDF collaborates with ISO in the development of standard methods of analysis and sampling for milk and milk products.

The main task of Standing Committees is to prepare International Standards. Draft International Standards adopted by the Standing Committees are circulated to the National Committees for endorsement prior to publication as an International Standard. Publication as an International Standard requires approval by at least 50 % of the IDF National Committees casting a vote.

Attention is drawn to the possibility that some of the elements of this document may be the subject of patent rights. IDF shall not be held responsible for identifying any or all such patent rights.

ISO 17678|IDF 202 was prepared by the International Dairy Federation (IDF) and Technical Committee ISO/TC 34, *Food products*, Subcommittee SC 5, *Milk and milk products*. It is being published jointly by IDF and ISO.

All work was carried out by the Joint ISO-IDF Project Group on *Foreign fats* of the Standing Committee on *Analytical methods for composition* under the aegis of its project leader, Dr J. Molкетин (DE).

Milk and milk products — Determination of milk fat purity by gas chromatographic analysis of triglycerides (Reference method)

1 Scope

This International Standard specifies a reference method for the determination of milk fat purity using gas chromatographic analysis of triglycerides. Both vegetable fats and animal fats such as beef tallow and lard can be detected. By using defined triglyceride equations, the integrity of milk fat is determined.

Basically, the method applies to bulk milk, or products made thereof, irrespective of feeding, breed or lactation conditions. In particular, the method is applicable to fat extracted from milk products purporting to contain pure milk fat with unchanged composition, such as butter, cream, milk, and milk powder.

However, under the circumstances listed hereafter, a false positive result can be obtained. Hence, the method is not applicable to milk fat:

- a) obtained from bovine milk other than cow's milk;
- b) obtained from single cows;
- c) obtained from cows which received an exceptionally high feeding of pure vegetable oils such as rapeseed oil;
- d) obtained from colostrum;
- e) subjected to technological treatment such as removal of cholesterol or fractionation;
- f) obtained from skim milk or buttermilk;
- g) extracted by using the Gerber, Weibull–Berntrop or Schmid–Bondzynski–Ratzlaff methods, or that has been isolated using detergents (e.g. the Bureau of Dairy Industries method).

With the extraction methods specified in g), substantial quantities of partial glycerides or phospholipids can pass into the fat phase. Consequently, the scope of this International Standard excludes certain products and particularly cheese, whose ripening process can also affect the fat composition to such a degree that a false positive result is obtained.

NOTE 1 In nature, butyric (*n*-butanoic) acid (C4) occurs exclusively in milk fat and enables quantitative estimations of low to moderate amounts of milk fat in vegetable and animal fats to be made. However, due to the large variation of C4, whose approximate content ranges from 3,1 % mass fraction to 3,8 % mass fraction, it is difficult to provide qualitative and quantitative information for foreign fat to pure milk fat ratios of up to 20 % mass fraction (see Reference [11]).

NOTE 2 In practice, quantitative results cannot be derived from the sterol content of vegetable fats, because they depend on production and processing conditions. Furthermore, the qualitative determination of foreign fat using sterols is ambiguous.

2 Normative references

The following referenced documents are indispensable for the application of this document. For dated references, only the edition cited applies. For undated references, the latest edition of the referenced document (including any amendments) applies.

ISO 1211|IDF 1, *Milk — Determination of fat content — Gravimetric method (Reference method)*

ISO 2450|IDF 16, *Cream — Determination of fat content — Gravimetric method (Reference method)*

ISO 3696, *Water for analytical laboratory use — Specification and test methods*

ISO 7328|IDF 116, *Milk-based edible ices and ice mixes — Determination of fat content — Gravimetric method (Reference method)*

3 Terms and definitions

For the purposes of this document, the following terms and definitions apply.

3.1 milk fat purity

absence of vegetable and animal fats determined by the procedure specified in this International Standard

NOTE The purity is determined using *S*-values, which are calculated from the content of triglycerides. Triglyceride mass fractions are expressed as percentages.

4 Principle

Fat extracted from milk or milk products is analysed by gas chromatography (GC) using a packed or a short capillary column to determine triglycerides (TGs), separated by total carbon numbers. By inserting the mass fraction, expressed as a percentage, of fat molecules of different sizes (C24 to C54, using even C numbers only) into suitable TG equations, *S*-values are calculated. If the *S*-values exceed the limits established with pure milk fat, the presence of foreign fat is detected.

NOTE 1 The suitability and equivalence of both packed and capillary columns have been demonstrated previously (see References [8] to [10]).

NOTE 2 An *S*-value is the sum of weighted TG mass fractions.

5 Reagents

During the analysis, unless otherwise stated, use only reagents of recognized analytical grade.

5.1 Water complying with the requirements of ISO 3696, grade 2.

5.2 Carrier gas, nitrogen or, alternatively, helium or hydrogen, all with a purity of at least 99,995 % volume fraction.

5.3 Fat standards, purity at least 99 % mass fraction, for standardizing the milk fat standard described in 8.3.3.

5.3.1 Triglyceride standards, saturated; suitable products are available commercially.

5.3.2 Cholesterol standard.

5.4 Methanol (CH₃OH), with a water content of not more than 0,05 % mass fraction.

5.5 *n*-Hexane [CH₃(CH₂)₄CH₃].

5.6 *n*-Heptane [CH₃(CH₂)₅CH₃].

5.7 Other gases, hydrogen, purity at least 99,995 % volume fraction, free from organic impurities (C_nH_m < 1 µl/l); synthetic air, free from organic impurities (C_nH_m < 1 µl/l).

5.8 Anhydrous sodium sulfate (Na₂SO₄).

6 Apparatus

Usual laboratory equipment and, in particular, the following.

6.1 High-temperature gas chromatograph, suitable for use at temperatures of at least 400 °C and equipped with a flame ionization detector (FID). For capillary GC, an on-column or a programmed temperature vaporization injector is indispensable while a split injector is unsuitable.

Septa used in the injector shall withstand high temperatures and exhibit a very low degree of “bleeding”. Always use graphite seals to connect the column as well as injector and/or detector inserts (where applicable).

6.2 Chromatography column.

6.2.1 Packed column, glass, of internal diameter 2 mm and length 500 mm, packed with a stationary phase of 3 % OV-1 on 125 µm to 150 µm (100 mesh to 120 mesh) Gas ChromQ¹).

The preparation, silanization, packing and conditioning of the packed column is described in Annex A.

Alternatively, a capillary column (6.2.2) may be used.

6.2.2 Capillary column, short, e.g. of length 5 m, with a non-polar stationary phase that can withstand temperatures up to 400 °C or more²).

Condition the column by performing 20 analyses of a milk fat solution (8.2) within no more than 2 days by using the settings given in 8.3.4.2. After that, ensure that the response factors (8.3.3) are close to 1 and not higher than 1,250 0.

Because of the variable overlap between C24 and cholesterol, a higher response factor may be accepted for C24.

Columns with different dimensions and a different non-polar, highly temperature-resistant phase may be used as long as their performance is consistent with this International Standard. However, the column length is restricted by the indispensable limitation in resolution as shown in Figure 1. See also 8.3.4.2.

6.3 Extrelut column¹), capacity 1 ml to 3 ml, filled with silica gel, for the extraction of milk fat in accordance with 8.1.4 only.

6.4 Graphite seals, capable of withstanding temperatures of at least 400 °C; for the connection of the GC column as well as for the injector and/or detector inserts.

6.5 Water bath, capable of being maintained at 50 °C ± 2 °C.

6.6 Oven, capable of operating at 50 °C ± 2 °C and 100 °C ± 2 °C.

1) Example of a suitable product available commercially. This information is given for the convenience of users of this International Standard and does not constitute an endorsement by ISO or by IDF of this product.

2) CP-Ultimetal SimDist (5 m, 0,53 mm, 0,17 µm) is an example of a suitable product available commercially. This information is given for the convenience of users of this International Standard and does not constitute an endorsement by ISO or by IDF of this product.

6.7 Micropipette.

6.8 Graduated pipette, capacity 5 ml, ISO 835^[2] class A.

6.9 Round-bottomed flask, capacity 50 ml.

6.10 Erlenmeyer flask, nominal capacity 250 ml.

6.11 Funnel.

6.12 Fine-pored filter paper.

6.13 Rotary evaporator.

6.14 Ampoules, nominal capacity 1 ml, fitted with a polytetrafluoroethylene-lined aluminium crimp cap or screw cap.

6.15 Injection syringe, with syringe plunger not reaching into the tip of the needle (packed column GC).

NOTE With these syringes, better repeatability of the results is obtained.

6.16 Analytical balance, capable of weighing to the nearest 1 mg, with a readability of 0,1 mg.

7 Sampling

Sampling is not part of the method specified in this International Standard. A recommended sampling method is given in ISO 707 | IDF 50^[1].

A representative sample should have been sent to the laboratory. It should not have been damaged or changed during transport or storage.

8 Procedure

8.1 Preparation of test samples

8.1.1 General

For the preparation of test samples, use one of the milk fat isolation or extraction methods specified in 8.1.2 to 8.1.4.

8.1.2 Isolation from butter or butteroil

Melt 50 g to 100 g of test sample in the water bath (6.5) or the oven (6.6) at 50 °C.

Add 0,5 g to 1,0 g of sodium sulfate (5.8) to a folded filter paper (6.12). Preheat a 250 ml Erlenmeyer flask (6.10) and a funnel (6.11) with the filter paper inserted, containing the sodium sulfate, in the oven (6.6) at 50 °C.

When a limited amount of test sample is available, use a smaller test sample and adapt the procedure accordingly.

However, note that the handling of a smaller test portion involves a higher risk of obtaining a non-representative sample.

While keeping the preheated flask, funnel, and inserted filter device in the oven, filter the fat layer of the molten sample without transferring any serum.

NOTE 1 Butter can be obtained from cream by churning and thorough washing of the resulting butter grain.

NOTE 2 The milk fat obtained using the procedure in this subclause is almost free of phospholipids.

8.1.3 Extraction according to the Röse–Gottlieb gravimetric method

Extract the fat fraction from the test sample by using the gravimetric method specified in one of: ISO 1211|IDF 1, ISO 2450|IDF 16 or ISO 7328|IDF 116.

8.1.4 Extraction from milk using silica gel columns

Temper the milk to 20 °C. Using a micropipette (6.7), add 0,7 ml of the sample thus prepared into a 1 ml to 3 ml Extrelut column (6.3). Allow the sample to distribute uniformly on the silica gel for approximately 5 min.

To denature the protein–lipid complexes, using the graduated pipette (6.8), add 1,5 ml of methanol (5.4) to the Extrelut column. Subsequently, extract the fat fraction from the test sample with 20 ml of *n*-hexane (5.5). Add the *n*-hexane slowly in small amounts. Collect the solvent draining off in a 50 ml round-bottomed flask (6.9), previously dried to a constant, known mass weighed to the nearest 1 mg and record the mass to 0,1 mg.

Allow the column to drain until empty after the extraction. Distil off the solvents from the eluate on a rotary evaporator (6.13) with its water bath maintained at between 40 °C and 50 °C.

After distilling off the solvents, dry and subsequently weigh the round-bottomed flask and its contents to the nearest 1 mg, recording the mass to 0,1 mg. Determine the fat mass yield by subtracting the mass of the dried empty round-bottomed flask from the mass obtained.

Depending on the fat content of the milk and the required concentration of the sample solution, check whether it is necessary to combine the yield of two or more extractions to obtain an adequate amount of fat.

8.2 Preparation of fat sample solution

For gas chromatography with a packed column, prepare a 5 % volume fraction solution of the fat obtained in 8.1.2, 8.1.3 or 8.1.4 in *n*-hexane (5.5) or *n*-heptane (5.6). Depending on the column dimensions, use a concentration of 1 % [0,53 mm internal diameter (ID), wide-bore] or lower for on-column injection with a capillary column.

When using the fat sample prepared in 8.1.4, calculate the amount of solvent (5.5 or 5.6) to be added to the test sample in the flask based on the mass of fat obtained.

Completely dissolve the fat in the solvent used. Transfer approximately 0,5 ml to 1 ml of the fat sample solution obtained into an ampoule (6.14).

8.3 Chromatographic triglyceride determination

8.3.1 Baseline drift

To minimize baseline rising, condition the column as specified in 6.2.2 (capillary column) or in Clause A.4 (packed column).

NOTE Because of the high column temperature, the analysis of TGs is particularly susceptible to a rise of the baseline in the high carbon-number range.

8.3.2 Injection technique

8.3.2.1 Packed column

To avoid discrimination effects and to improve the quantification of the high-boiling TG components, apply the hot-needle technique.

Fill the needle with air by drawing up the fat solution into the body of the syringe. Insert the needle into the injector. Heat the needle prior to injection for about 3 s. Then, rapidly inject the syringe contents.

8.3.2.2 Capillary column

When using cool on-column injection (8.3.4.2), insert the needle of the syringe and inject immediately. Choose a suitable subsequent dwell time of the needle in the injector so as to avoid broad tailing of the solvent peak.

NOTE The optimum dwell time is typically about 3 s.

8.3.3 Calibration

8.3.3.1 General

For the calibration of test samples, perform two to three analyses of standardized milk fat at the beginning of every working day. Use the last analysis of the standardized milk fat to determine the response factors, f_i (mass fraction divided by area fraction), of the TGs and of cholesterol and apply these to the subsequent test samples (see 10.1):

$$f_i = \frac{w_i \sum A_i}{\sum w_i A_i} \quad (1)$$

where

w_i is the mass fraction, expressed as a percentage, of each TG or cholesterol in the standardized milk fat;

A_i is the numerical value of the peak area of each TG or cholesterol in the standardized milk fat.

Express the response factors to four decimal places.

Proceed in accordance with either 8.3.3.2 or 8.3.3.3 to obtain a standardized milk fat with a known TG composition.

8.3.3.2 Commercial milk fat standard

Use a standardized milk fat with a certified TG composition³⁾ to determine the response factor of each constituent of the test sample.

8.3.3.3 Laboratory milk fat standard

Prepare about 1 g of a mixture of the fat standards (5.3) — containing at least the saturated TGs, C24, C30, C36, C42, C48 and C54, as well as cholesterol; plus, preferably, C50 and C52 — by weighing to the nearest 1 mg and recording the mass to 0,1 mg to obtain a relative TG composition similar to milk fat.

Analyse repeatedly a solution of the fat standards mixture in *n*-hexane (5.5) or *n*-heptane (5.6) in accordance with 8.3.4. In the same sequence, analyse repeatedly milk fat of typical composition.

Determine the TG response factors from the fat standards mixture. Calculate the intermediate response factors of TGs not present in the mixture by mathematical interpolation. Apply the response factors obtained to the milk fat in order to obtain a standardized composition.

The standardized milk fat thus obtained has a stock life of several years, if stored under nitrogen at a maximum temperature of $-18\text{ }^{\circ}\text{C}$.

3) CRM 519 (anhydrous milk fat) is an example of a suitable product available commercially. This information is given for the convenience of users of this International Standard and does not constitute an endorsement by ISO or by IDF of this product.

8.3.4 Chromatographic conditions

8.3.4.1 Packed column

8.3.4.1.1 Use of a packed column generally results in a resolution similar to that in Figure 1. Although not normally observed, avoid splitting of the even-numbered TGs.

8.3.4.1.2 Temperature programme: set the initial oven temperature to 210 °C. Maintain it at that temperature for 1 min. Then increase the temperature at a rate of 6 °C/min to 350 °C. Maintain it at that (final) temperature for 5 min.

8.3.4.1.3 Detector and injector temperatures: set both at 370 °C.

8.3.4.1.4 Carrier gas: use nitrogen at a constant flow rate of about 40 ml/min. Adjust the exact carrier gas flow in such a manner that C54 is eluted at 341 °C.

8.3.4.1.5 Duration of analysis: 29,3 min.

8.3.4.1.6 Injection volume: inject 0,5 µl of a 5 % volume fraction sample solution.

8.3.4.1.7 When no TG analyses are being carried out, maintain the initial oven temperature as given in 8.3.4.1.2, the detector and injector temperatures as in 8.3.4.1.3, and the carrier gas flow rate as in 8.3.4.1.4 at a constant level, also overnight and during weekends and holidays. This ensures optimum performance of the column.

8.3.4.2 Capillary column

8.3.4.2.1 Use of a capillary column generally results in a resolution similar to that in Figure 1. Although not normally observed, avoid splitting of the even-numbered TGs.

8.3.4.2.2 Temperature programme: set the initial oven temperature 80 °C. Maintain it at that temperature for 0,5 min. Then increase the temperature at a rate of 50 °C/min to 190 °C and subsequently at a rate of 6 °C/min to 350 °C. Maintain it at that (final) temperature for 5 min.

8.3.4.2.3 Detector temperature: set at 370 °C.

8.3.4.2.4 Carrier gas: use nitrogen at a constant flow rate of about 3 ml/min.

8.3.4.2.5 Duration of analysis: 34,4 min.

8.3.4.2.6 Injection volume: inject 0,5 µl of a 1 % volume fraction sample solution.

8.3.4.2.7 Maintain these settings during standby to ensure best performance (see 8.3.4.1.7).

When using cool on-column injection, set the injector temperature to oven track mode to obtain best results.

The analytical settings given in 8.3.4.2 are suitable for use with on-column injection on to a wide-bore column (0,53 mm ID) as specified in 6.2.2. Different conditions may be applied if another column dimension or phase is used. The scope includes the use of ultrafast GC. In any case, be aware of the indispensable requirement for appropriate resolution (see Figure 1).

9 Integration, evaluation and control of the analytical performance

Evaluate the chromatogram peaks with an integration system capable of baseline drawing and reintegration.

Figure 1 shows an example of a correctly integrated chromatogram, whereas Figure 2 demonstrates an example of a sporadic error in the baseline ending after C54 that influences the percentages of all TGs. Nevertheless, exclude peaks eluting after C54 from the evaluation.

Combine TGs with an odd acyl-C number ($2n + 1$) with the preceding even-numbered TG ($2n$). Do not take into account the low C56 content. Multiply the area percentages of the remaining TGs, including cholesterol, by the corresponding response factors of the standardized milk fat (latest calibration) and normalize altogether to 100 % in accordance with 10.1.

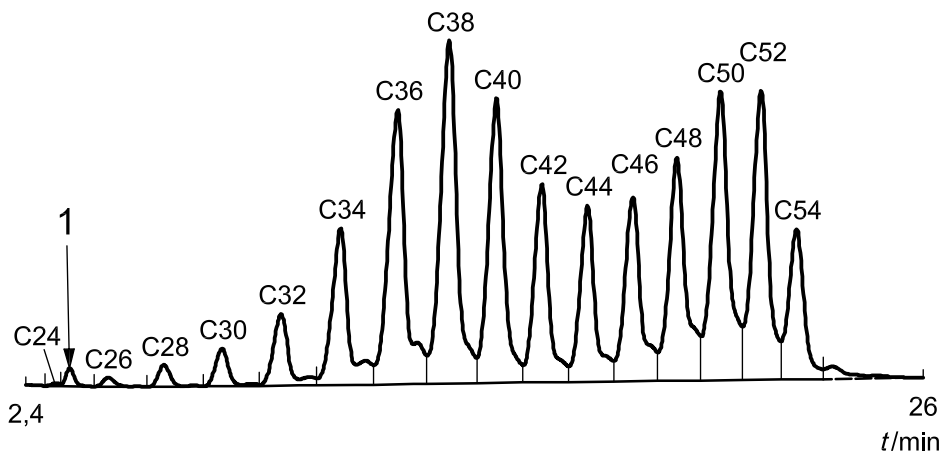

Key
1 cholesterol
t time

Figure 1 — Example of a triglyceride chromatogram of milk fat with baseline set correctly

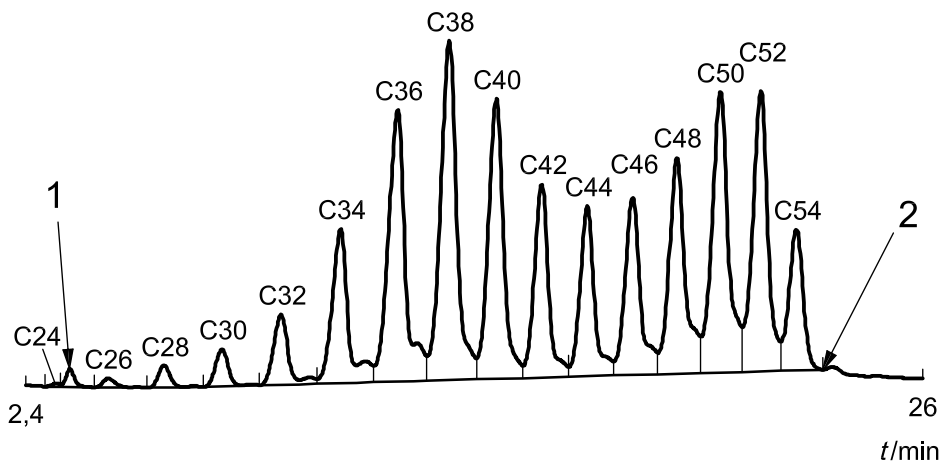

Key
1 cholesterol
2 incorrect baseline end point
t time

Figure 2 — Example of a triglyceride chromatogram of milk fat with baseline set incorrectly

To check measurement conditions, compare the coefficient of variation, C_V , expressed as a percentage, of the various TGs obtained from at least 10 analyses with those given in Table 1 which are based on 19 consecutive analyses of the same milk fat sample.

If the values of C_V obtained are considerably higher than the values given in Table 1, the chromatographic conditions are not appropriate.

NOTE The values given in Table 1 are not mandatory, but are indicative for quality control purposes.

If, however, those higher C_V values are accepted, the repeatability and reproducibility limits given in Clause 11 shall nonetheless be complied with.

Table 1 — Coefficients of variation of triglyceride contents

Triglyceride	Coefficient of variation C_V %
C24	10,00
C26	2,69
C28	3,03
C30	1,76
C32	1,03
C34	0,79
C36	0,25
C38	0,42
C40	0,20
C42	0,26
C44	0,34
C46	0,37
C48	0,53
C50	0,38
C52	0,54
C54	0,75

10 Calculation and expression of results

10.1 Triglyceride composition

10.1.1 Calculation

Calculate the mass fraction of each TG (for $i = \text{C24, C26, C28, C30, C32, C34, C36, C38, C40, C42, C44, C46, C48, C50, C52 to C54}$) plus cholesterol, w_i , expressed as a percentage, of the total TG content of the test sample using Equation (2):

$$w_i = \frac{A_i f_i}{\sum (A_i f_i)} \times 100 \quad (2)$$

where

A_i is the numerical value of the peak area of each TG in the test sample;

f_i is the response factor of each TG determined by calibration (8.3.3).

10.1.2 Expression of test results

Express the results to two decimal places.

10.2 S-values

10.2.1 Calculation

10.2.1.1 General

Calculate the S -values by inserting the calculated w_i (10.1.1) of the appropriate TG percentages into Equations (3) to (7). Use all equations irrespective of the kind of foreign fat suspected.

NOTE Although the S -values are calculated from TG percentages, they do not represent a percentage themselves and do not have a unit.

10.2.1.2 Soy bean, sunflower, olive, rapeseed, linseed, wheat germ, maize germ, cotton seed and fish oil

$$S = 2,098\ 3\ w_{C30} + 0,728\ 8\ w_{C34} + 0,692\ 7\ w_{C36} + 0,635\ 3\ w_{C38} + 3,745\ 2\ w_{C40} - 1,292\ 9\ w_{C42} + 1,354\ 4\ w_{C44} + 1,701\ 3\ w_{C46} + 2,528\ 3\ w_{C50} \quad (3)$$

10.2.1.3 Coconut and palm kernel fat

$$S = 3,745\ 3\ w_{C32} + 1,113\ 4\ w_{C36} + 1,364\ 8\ w_{C38} + 2,154\ 4\ w_{C42} + 0,427\ 3\ w_{C44} + 0,580\ 9\ w_{C46} + 1,292\ 6\ w_{C48} + 1,030\ 6\ w_{C50} + 0,995\ 3\ w_{C52} + 1,239\ 6\ w_{C54} \quad (4)$$

10.2.1.4 Palm oil and beef tallow

$$S = 3,664\ 4\ w_{C28} + 5,229\ 7\ w_{C30} - 12,507\ 3\ w_{C32} + 4,428\ 5\ w_{C34} - 0,201\ 0\ w_{C36} + 1,279\ 1\ w_{C38} + 6,743\ 3\ w_{C40} - 4,271\ 4\ w_{C42} + 6,373\ 9\ w_{C46} \quad (5)$$

10.2.1.5 Lard

$$S = 6,512\ 5\ w_{C26} + 1,205\ 2\ w_{C32} + 1,733\ 6\ w_{C34} + 1,755\ 7\ w_{C36} + 2,232\ 5\ w_{C42} + 2,800\ 6\ w_{C46} + 2,543\ 2\ w_{C52} + 0,989\ 2\ w_{C54} \quad (6)$$

10.2.1.6 Total

$$S = -2,757\ 5\ w_{C26} + 6,407\ 7\ w_{C28} + 5,543\ 7\ w_{C30} - 15,324\ 7\ w_{C32} + 6,260\ 0\ w_{C34} + 8,010\ 8\ w_{C40} - 5,033\ 6\ w_{C42} + 0,635\ 6\ w_{C44} + 6,017\ 1\ w_{C46} \quad (7)$$

10.2.2 Expression of test results

Express the results to two decimal places.

10.3 Detection of foreign fat

Compare the five S -values obtained in 10.2.1 with the corresponding S -limits given in Table 2. Consider the test sample as a pure milk fat when all five S -values fall inside the limits mentioned in Table 2. However, if any S -value falls outside the corresponding limits, consider the sample to contain a foreign fat.

Though individual Equations (3) to (6) are more sensitive for certain foreign fats than total Equation (7) (see Table B.1), a positive result obtained with only one of Equations (3) to (6) does not allow conclusions to be drawn on the kind of foreign fat.

Annex B describes a procedure for the calculation of the content of vegetable or animal fat in the adulterated milk fat which has not been validated and is for information only.

Table 2 — *S*-limits for pure milk fats

Foreign fat	Equation	<i>S</i> -limits ^a
Soy bean, sunflower, olive, rapeseed, linseed, wheat germ, maize germ, cotton seed, fish oil	(3)	98,05 to 101,95
Coconut and palm kernel fat	(4)	99,42 to 100,58
Palm oil and beef tallow	(5)	95,90 to 104,10
Lard	(6)	97,96 to 102,04
Total	(7)	95,68 to 104,32

^a Calculated on a 99 % confidence level, so that foreign fat addition is only indicated if the detection limits of the relevant equation are exceeded (see Table B.1).

11 Precision

11.1 Interlaboratory test

The repeatability and reproducibility of *S*-values were derived from the result of an interlaboratory test carried out in accordance with ISO 5725-1^[3] and ISO 5725-2^[4]. The repeatability and reproducibility values were determined using Equations (3) to (7) by analysing pure milk fat and may not be applicable to matrices other than those given. Details of the interlaboratory test are given in Annex D.

NOTE The repeatability and reproducibility limits can be used to calculate the uncertainty of measurement. The resulting extended *S*-limits are given in Annex C for information.

11.2 Repeatability

The absolute difference between two single test results, obtained using the same method on identical test material in the same laboratory by the same operator using the same equipment within a short interval of time, will not exceed the limits listed in Table 3 in more than 5 % of cases.

Table 3 — Repeatability limits, *r*, for Equations (3) to (7)

Foreign fat	Equation	<i>r</i>
Soy bean, sunflower, olive, rapeseed, linseed, wheat germ, maize germ, cotton seed, fish oil	(3)	0,22
Coconut and palm kernel fat	(4)	0,11
Palm oil and beef tallow	(5)	0,57
Lard	(6)	0,28
Total	(7)	0,66

11.3 Reproducibility

The absolute difference between two single test results, obtained using the same method on identical test material in different laboratories with different operators using different equipment, will not exceed the limits listed in Table 4 in more than 5 % of cases.

Table 4 — Reproducibility limits, R , for Equations (3) to (7)

Foreign fat	Equation	R
Soy bean, sunflower, olive, rapeseed, linseed, wheat germ, maize germ, cotton seed, fish oil	(3)	0,61
Coconut and palm kernel fat	(4)	0,26
Palm oil and beef tallow	(5)	1,02
Lard	(6)	0,38
Total	(7)	1,26

12 Test report

The test report shall contain at least the following information:

- a) all information necessary for the complete identification of the sample;
- b) the sampling method used, if known;
- c) the test method used, with reference to this International Standard (ISO 17678 | IDF 202:2010);
- d) all operational details not specified in this International Standard, or regarded as optional, together with details of any incidents which may have influenced the test result(s);
- e) the test result(s) obtained, and, if the repeatability has been checked, the final quoted result obtained.

Annex A (normative)

Preparation of the packed column

A.1 Reagents, apparatus, and materials

A.1.1 Toluene ($C_6H_5CH_3$).

A.1.2 Dimethyldichlorosilane [$Si(CH_3)_2Cl_2$] **solution**. Dissolve 50 ml dimethyldichlorosilane in 283 ml toluene (A.1.1).

A.1.3 Cocoa butter solution, with a mass fraction of 5 % cocoa butter in *n*-hexane (5.5) or *n*-heptane (5.6).

A.1.4 Stationary phase, 3 % OV-1 on 125 μm to 150 μm (100 mesh to 120 mesh) Gas ChromQ⁴).

NOTE The indication of grain was converted to micrometres in accordance with BS 410 (all parts)^[5].

A.1.5 Glass column, of internal diameter 2 mm and of length 500 mm, U-shaped.

A.1.6 Apparatus, for filling the packed column.

A.1.6.1 Filling column, with screwed-on end caps, provided with a mark up to which the required quantity of stationary phase can be filled.

A.1.6.2 Fine sieve, with mesh size of about 100 μm and a screw cap suitable for hermetically sealing the glass column (see Clause A.3).

A.1.6.3 Silanized glass wool, deactivated.

A.1.6.4 Vibrator, for uniform distribution of the stationary phase during filling.

A.1.6.5 Silanizing devices, for silanizing the glass surface of the column.

A.1.6.6 Woulff bottle.

A.1.6.7 Water suction pump.

A.2 Silanization (deactivation of the glass surface)

After connecting the Woulff bottle (A.1.6.6) to the water suction pump (A.1.6.7), dip tube 2 (see Figure A.1) into the dimethylchlorosilane solution (A.1.2). Fill the glass column (A.1.5) with that solution by closing the stopcock. Open the stopcock again and subsequently remove the two tubes.

Fix the column on a stand. Completely fill it using a pipette with dimethyldichlorosilane solution (A.1.2). Let the column stand for 20 min to 30 min.

4) Example of a suitable product available commercially. This information is given for the convenience of users of this International Standard and does not constitute an endorsement by ISO or by IDF of this product.

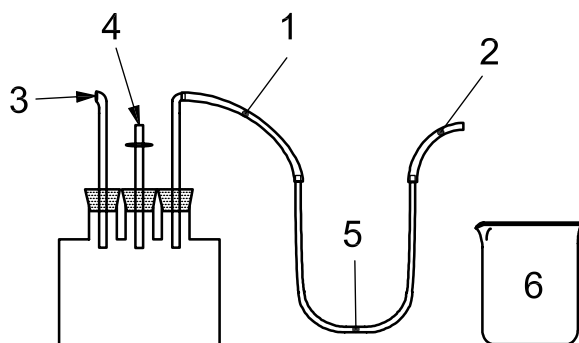

Key

- 1 tube 1
- 2 tube 2
- 3 water suction pump
- 4 stopcock
- 5 glass column
- 6 dimethylchlorosilane and toluene

Figure A.1 — Silanization apparatus

Then replace the Woulff bottle by a filter flask. Empty the column by connecting it to the water suction pump (A.1.6.7) (see Figure A.2). Rinse the emptied column using successively 75 ml of toluene (A.1.1) and 50 ml of methanol (5.4) by dipping tube 2 into the respective solvents. Dry the rinsed column in the oven (6.6) maintained at 100 °C for approximately 30 min.

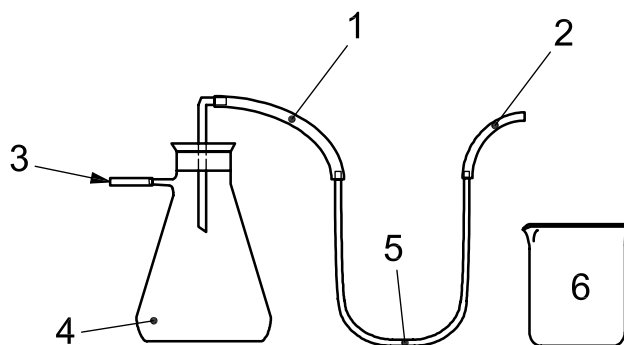

Key

- 1 tube 1
- 2 tube 2
- 3 water suction pump
- 4 filter flask
- 5 glass column
- 6 rinsing agent

Figure A.2 — Rinsing apparatus

A.3 Filling

Fill the glass column by using the apparatus represented in Figure A.3. Fill the stationary phase (A.1.4) in the filling column (A.1.6.1) up to the mark. Seal the lower end of the glass column to be filled with an approximately 10 mm long plug of silanized, compressed glass wool (A.1.6.3). Close the end of the column with the fine sieve (A.1.6.2).

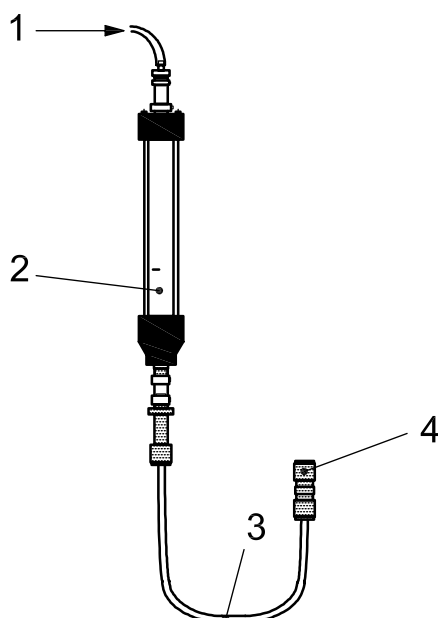

Key

- 1 nitrogen inlet
- 2 filling column, to be filled up to the mark with OV-1
- 3 glass column to be filled
- 4 screw cap with filter, against which the glass fibre and stationary phase are pressed

Figure A.3 — Filling of the glass column

Fill the glass column under pressure (300 kPa and a flow of nitrogen) with the stationary phase. To obtain a uniform, continuous, and firm packing, move a vibrator up and down the glass column during filling. After filling, press a solid plug of silanized glass wool (A.1.6.3) into the other end of the packed column thus obtained. Cut off the protruding ends. Press the plug a few millimetres into the packed column with a spatula.

A.4 Conditioning

During steps a) to c), do not connect the back end of the packed column (Clause A.3) to the detector to avoid contamination. Condition the column as follows.

- a) Flush the packed column with nitrogen for 15 min, with the flow speed set at 40 ml/min and the GC oven set at 50 °C.
- b) Heat the column at a rate of 1 °C/min up to 355 °C, with the nitrogen flow rate set at 10 ml/min.
- c) Hold the column at 355 °C for 12 h to 15 h.

- d) Inject two times 1 µl of cocoa butter solution (A.1.3) using the temperature program for the packed column given in 8.3.4.1.

NOTE Cocoa butter consists almost exclusively of high-boiling C50 to C54 TGs and, thus, reduces the effort of column conditioning with regard to the respective response factors.

- e) Inject 20 times 0,5 µl of a milk fat solution in accordance with 8.2 within no more than 2 days using the settings for the packed column given in 8.3.4.1.

Use only packed columns with response factors close to 1 for the analysis of test samples. Response factors shall not be higher than 1,250 0.

Annex B (informative)

Quantification of the foreign fat content

B.1 General

Table B.1 indicates the detection limits for various foreign fats calculated on a 99 % confidence level. The middle column shows the detection limits of the best individual Equation of (3) to (6).

The detection limits of the total Equation (7), shown in the rightmost column, are somewhat higher. In principle, Equation (7) is only needed for the quantification of foreign fat.

With all equations, combinations of various foreign fats can also be detected. The variation of the TG composition between individual samples of one kind of foreign fat has no significant influence on detection limits.

When using both the individual equations and the total equation, the detection limits of the individual equations apply. However, the *S*-value of the total equation is needed for quantification in certain cases (see Clause B.2).

Table B.1 — 99 % Limits of detection of foreign fat added to milk fat as percentages

Foreign fat	Individual equation %	Total equation %
Soy bean oil	2,1	4,4
Sunflower oil	2,3	4,8
Olive oil	2,4	4,7
Coconut oil	3,5	4,3
Palm oil	4,4	4,7
Palm kernel fat	4,6	5,9
Rapeseed oil	2,0	4,4
Linseed oil	2,0	4,0
Wheat germ oil	2,7	6,4
Maize germ oil	2,2	4,5
Cotton seed oil	3,3	4,4
Lard	2,7	4,7
Beef tallow	5,2	5,4
Hydrogenated fish oil	5,4	6,1

B.2 Calculation

Perform a quantitative foreign fat determination only if at least one of the S -limits (Table 2 or Table C.1) is exceeded. In order to obtain quantitative information, calculate the foreign fat mass fraction or foreign fat mixture mass fraction, w_f , expressed as a percentage, in the test sample using Equation (B.1):

$$w_f = 100 \times \left| \frac{(100 - S)}{(100 - S_f)} \right| \quad (\text{B.1})$$

where

S is the result obtained by inserting TG data from milk fat to which a foreign fat or foreign fat mixture has been added into one of Equations (3) to (7);

S_f is a constant, depending on the kind of foreign fat added.

If the kind of foreign fat added to milk fat is not known, use a general S_f value of 7,46 (see Table B.2). Always use the S value obtained from Equation (7), even if its S limits are not exceeded, but those of another equation are.

With known foreign fats, insert their individual S_f values (see Table B.2) into Equation (B.1). Choose the relevant foreign fat equation from Equations (3) to (6) to calculate S .

Table B.2 — S_f values of various foreign fats

Foreign fat	S_f
Unknown	7,46
Soy bean oil	8,18
Sunflower oil	9,43
Olive oil	12,75
Coconut oil	118,13
Palm oil	7,55
Palm kernel oil	112,32
Rapeseed oil	3,30
Linseed oil	4,44
Wheat germ oil	27,45
Maize germ oil	9,29
Cotton seed oil	41,18
Lard	177,55
Beef tallow	17,56
Fish oil	64,12

B.3 Expression of results

Express the test results to two decimal places.

Annex C
(informative)

Uncertainty of measurement

C.1 Expanded uncertainty

With the obtained values for the repeatability, r (11.2), and the reproducibility, R (11.3), the expanded uncertainty for an S value can be calculated.

Inclusion of the expanded uncertainty (based on duplicate analyses) into the S limits of Table 2 results in extended S limits shown in Table C.1.

Table C.1 — Extended S limits for pure milk fats including the expanded uncertainty

Foreign fat	Equation	Extended S limits
Soy bean, sunflower, olive, rapeseed, linseed, wheat germ, maize germ, cotton seed, fish oil	(3)	97,63 to 102,37
Coconut and palm kernel fat	(4)	99,24 to 100,76
Palm oil and beef tallow	(5)	95,23 to 104,77
Lard	(6)	97,73 to 102,27
Total	(7)	94,84 to 105,16

NOTE The extended S limits indicated in Table C.1 are not part of this International Standard, but can be useful for the evaluation of compliance of a sample with official regulations.

Annex D (informative)

Interlaboratory test

An international collaborative test involving 15 laboratories from nine countries was carried out on eight anhydrous milk fat samples originating from Europe, South Africa, and New Zealand. The eight test samples were divided into 16 blind duplicate samples. The test was organized by the Max Rubner Institute (MRI), Department of Safety and Quality of Milk and Fish Products (DE). The results refer to the calculated S values having no unit.

After careful consideration, the results of five laboratories were discarded for technical or methodical reasons. The remaining results were subjected to statistical evaluation in accordance with the methodology of ISO 5725-1^[3] and ISO 5725-2^[4] to give the precision data shown in Tables D.1 to D.5.

NOTE Detailed results of the interlaboratory study appear in Reference [13].

Table D.1 — Results of the interlaboratory test: Equation (3)

Soy bean equation	Anhydrous milk fat								Mean
	1	2	3	4	5	6	7	8	
Retained laboratories (w/o outliers)	10	10	8	8	10	8	9	9	
Mean value	99,89	99,72	99,78	99,60	99,75	99,23	100,18	100,62	
Repeatability standard deviation, s_r	0,03	0,05	0,08	0,07	0,14	0,05	0,14	0,07	0,08
Coefficient of variation of repeatability	0,03	0,05	0,08	0,07	0,14	0,05	0,14	0,07	0,08
Repeatability limit, r (2,8 s_r)	0,09	0,14	0,21	0,19	0,39	0,15	0,39	0,20	0,22
Reproducibility standard deviation, s_R	0,19	0,25	0,14	0,19	0,23	0,24	0,26	0,23	0,22
Coefficient of variation of reproducibility	0,19	0,25	0,14	0,19	0,23	0,24	0,26	0,23	0,22
Reproducibility limit, R (2,8 s_R)	0,53	0,70	0,40	0,53	0,64	0,66	0,74	0,65	0,61

Table D.2 — Results of the interlaboratory test: Equation (4)

Coconut equation	Anhydrous milk fat								Mean
	1	2	3	4	5	6	7	8	
Retained laboratories (w/o outliers)	9	10	9	10	10	9	10	10	
Mean value	99,84	99,87	99,93	99,93	99,91	100,11	99,87	99,89	
Repeatability standard deviation, s_r	0,03	0,06	0,03	0,05	0,04	0,02	0,03	0,04	0,04
Coefficient of variation of repeatability	0,03	0,06	0,03	0,05	0,04	0,02	0,03	0,04	0,04
Repeatability limit, r (2,8 s_r)	0,09	0,16	0,10	0,14	0,12	0,06	0,08	0,12	0,11
Reproducibility standard deviation, s_R	0,06	0,11	0,11	0,09	0,09	0,10	0,11	0,07	0,09
Coefficient of variation of reproducibility	0,06	0,11	0,11	0,09	0,09	0,10	0,11	0,07	0,09
Reproducibility limit, R (2,8 s_R)	0,18	0,31	0,30	0,25	0,25	0,28	0,31	0,20	0,26

Table D.3 — Results of the interlaboratory test: Equation (5)

Palm oil equation	Anhydrous milk fat								Mean
	1	2	3	4	5	6	7	8	
Retained laboratories (w/o outliers)	9	10	9	8	10	9	9	9	
Mean value	100,58	99,83	100,04	99,98	100,36	99,12	102,02	101,71	
Repeatability standard deviation, s_r	0,10	0,21	0,32	0,20	0,28	0,21	0,18	0,11	0,20
Coefficient of variation of repeatability	0,10	0,21	0,32	0,20	0,28	0,22	0,18	0,10	0,20
Repeatability limit, r ($2,8 s_r$)	0,28	0,59	0,90	0,57	0,79	0,60	0,51	0,30	0,57
Reproducibility standard deviation, s_R	0,26	0,38	0,47	0,25	0,37	0,32	0,54	0,32	0,37
Coefficient of variation of reproducibility	0,26	0,38	0,47	0,25	0,37	0,32	0,53	0,32	0,36
Reproducibility limit, R ($2,8 s_R$)	0,73	1,07	1,33	0,71	1,04	0,89	1,52	0,90	1,02

Table D.4 — Results of the interlaboratory test: Equation (6)

Lard equation	Anhydrous milk fat								Mean
	1	2	3	4	5	6	7	8	
Retained laboratories (w/o outliers)	10	9	9	10	9	10	9	10	
Mean value	100,33	100,42	100,35	100,53	100,26	100,61	100,05	99,43	
Repeatability standard deviation, s_r	0,09	0,06	0,13	0,06	0,10	0,10	0,12	0,15	0,10
Coefficient of variation of repeatability	0,09	0,06	0,13	0,06	0,10	0,10	0,12	0,15	0,10
Repeatability limit, r ($2,8 s_r$)	0,26	0,17	0,37	0,16	0,27	0,29	0,34	0,41	0,28
Reproducibility standard deviation, s_R	0,13	0,13	0,13	0,16	0,10	0,15	0,12	0,16	0,14
Coefficient of variation of reproducibility	0,13	0,13	0,13	0,16	0,10	0,15	0,12	0,16	0,13
Reproducibility limit, R ($2,8 s_R$)	0,36	0,36	0,37	0,45	0,27	0,43	0,34	0,45	0,38

Table D.5 — Results of the interlaboratory test: Equation (7)

Total equation	Anhydrous milk fat								Mean
	1	2	3	4	5	6	7	8	
Retained laboratories (w/o outliers)	9	10	9	9	10	10	9	9	
Mean value	100,57	99,81	100,36	99,94	100,33	98,74	101,53	101,49	
Repeatability standard deviation, s_r	0,14	0,29	0,33	0,34	0,31	0,21	0,16	0,11	0,24
Coefficient of variation of repeatability	0,14	0,29	0,33	0,34	0,31	0,21	0,16	0,11	0,24
Repeatability limit, r ($2,8 s_r$)	0,40	0,81	0,91	0,95	0,86	0,58	0,46	0,32	0,66
Reproducibility standard deviation, s_R	0,33	0,44	0,57	0,37	0,42	0,56	0,57	0,33	0,45
Coefficient of variation of reproducibility	0,33	0,45	0,57	0,37	0,42	0,56	0,56	0,33	0,45
Reproducibility limit, R ($2,8 s_R$)	0,93	1,25	1,60	1,04	1,19	1,56	1,59	0,92	1,26

Bibliography

- [1] ISO 707|IDF 50, *Milk and milk products — Guidance on sampling*
- [2] ISO 835, *Laboratory glassware — Graduated pipettes*
- [3] ISO 5725-1, *Accuracy (trueness and precision) of measurement methods and results — Part 1: General principles and definitions*
- [4] ISO 5725-2, *Accuracy (trueness and precision) of measurement methods and results — Part 2: Basic method for the determination of repeatability and reproducibility of a standard measurement method*
- [5] BS 410 (all parts), *Test sieves — Technical requirements and testing*⁵⁾
- [6] PRECHT, D. Control of milk fat purity by gas chromatographic triglyceride analysis. *Kiel. Milchwirtsch. Forschungsber.* 1991, **43**, pp. 219-242
- [7] PRECHT, D. Detection of adulterated milk fat by fatty acid and triglyceride analyses. *Fat Sci. Technol.* 1991, **93**, pp. 538-544
- [8] PRECHT, D., MOLKENTIN, J. Quantitative triglyceride analysis using short capillary columns. *Chrompack News* 1993, **4**, pp. 16-17
- [9] MOLKENTIN, J., PRECHT, D. Comparison of packed and capillary columns for quantitative gas chromatography of triglycerides in milk fat. *Chromatographia* 1994, **39**, pp. 265-270
- [10] MOLKENTIN, J., PRECHT, D. Equivalence of packed and capillary GC columns for detection of foreign fat in butter by use of the triglyceride formula method. *Chromatographia* 2000, **52**, pp. 791-797
- [11] MOLKENTIN, J., PRECHT, D. Representative determination of the butyric acid content in European milk fats. *Milchwissenschaft* 1997, **52**, pp. 82-85
- [12] MOLKENTIN, J. Detection of foreign fat in milk fat from different continents by triacylglycerol analysis. *Eur. J. Lipid Sci. Technol.* 2007, **109**, pp. 505-510
- [13] MOLKENTIN, J., CRAWFORD, R.A. International collaborative study on the gas-liquid chromatographic method for the determination of milk fat purity in milk and milk products by analysis of triglycerides — Draft International Standard ISO 17678|IDF 202. *Bull. IDF* 2009, (434), pp. 1-19
- [14] POVOLO, M., PELIZZOLA, V., CONTARINI, G. Directly resistively heated-column gas chromatography for the evaluation of cow milk fat purity. *Eur. J. Lipid Sci. Technol.* 2008, **110**, pp. 1050-1057

5) Equivalent to ISO 3310 (all parts).

ISO 17678:2010(E)
IDF 202:2010(E)

ICS 67.100.10

Price based on 22 pages