**Resistance welding — Welding current
measurement for resistance welding —**

**Part 3:
Current sensing coil**

*Soudage par résistance — Mesurage des courants en soudage par
résistance —*

Partie 3: Tore de mesure de courant



Reference number
ISO 17657-3:2005(E)

© ISO 2005

PDF disclaimer

This PDF file may contain embedded typefaces. In accordance with Adobe's licensing policy, this file may be printed or viewed but shall not be edited unless the typefaces which are embedded are licensed to and installed on the computer performing the editing. In downloading this file, parties accept therein the responsibility of not infringing Adobe's licensing policy. The ISO Central Secretariat accepts no liability in this area.

Adobe is a trademark of Adobe Systems Incorporated.

Details of the software products used to create this PDF file can be found in the General Info relative to the file; the PDF-creation parameters were optimized for printing. Every care has been taken to ensure that the file is suitable for use by ISO member bodies. In the unlikely event that a problem relating to it is found, please inform the Central Secretariat at the address given below.

© ISO 2005

All rights reserved. Unless otherwise specified, no part of this publication may be reproduced or utilized in any form or by any means, electronic or mechanical, including photocopying and microfilm, without permission in writing from either ISO at the address below or ISO's member body in the country of the requester.

ISO copyright office
Case postale 56 • CH-1211 Geneva 20
Tel. + 41 22 749 01 11
Fax + 41 22 749 09 47
E-mail copyright@iso.org
Web www.iso.org

Published in Switzerland

Contents

Page

Foreword.....	iv
Introduction	v
1 Scope	1
2 Normative references	1
3 Terms and definitions.....	1
4 Physical environment and operating conditions	2
5 Classification of current sensing coils and designation of product	2
5.1 Class of current sensing coils.....	2
5.2 Standard values of the conversion coefficient.....	2
5.3 Designation of products.....	3
6 Requirements for current sensing coils.....	3
6.1 Current sensing coil and connecting lead	3
6.2 Conversion coefficient	3
6.3 Measuring accuracy	4
6.4 Mechanical strength	4
6.5 Setting position error	4
6.6 Influence of ambient temperature	4
6.7 Thermal property of cover materials	4
6.8 Test.....	4
7 Test procedures	5
7.1 Conversion coefficient	5
7.2 Measuring accuracy	6
7.3 Mechanical tests	6
7.4 Setting position error test.....	8
7.5 Thermal test.....	8
7.6 Contact test	8
8 Marking	8
Annex A (informative) Design of current sensing coils	9
Annex B (informative) Governing parameters of the conversion coefficient	12
Annex C (informative) Type of current sensing coils and their recommended specification range	13
Annex D (informative) Frequency response of current sensing coils	17

Foreword

ISO (the International Organization for Standardization) is a worldwide federation of national standards bodies (ISO member bodies). The work of preparing International Standards is normally carried out through ISO technical committees. Each member body interested in a subject for which a technical committee has been established has the right to be represented on that committee. International organizations, governmental and non-governmental, in liaison with ISO, also take part in the work. ISO collaborates closely with the International Electrotechnical Commission (IEC) on all matters of electrotechnical standardization.

International Standards are drafted in accordance with the rules given in the ISO/IEC Directives, Part 2.

The main task of technical committees is to prepare International Standards. Draft International Standards adopted by the technical committees are circulated to the member bodies for voting. Publication as an International Standard requires approval by at least 75 % of the member bodies casting a vote.

Attention is drawn to the possibility that some of the elements of this document may be the subject of patent rights. ISO shall not be held responsible for identifying any or all such patent rights.

ISO 17657-3 was prepared by Technical Committee ISO/TC 44, *Welding and allied processes*, Subcommittee SC 6, *Resistance welding*.

ISO 17657 consists of the following parts, under the general title *Resistance welding — Welding current measurement for resistance welding*:

- *Part 1: Guidelines for measurement*
- *Part 2: Welding current meter with current sensing coil*
- *Part 3: Current sensing coil*
- *Part 4: Calibration system*
- *Part 5: Verification of welding current measuring system*

Introduction

Requests for official interpretations of any aspect of this part of ISO 17657 should be directed to the Secretariat of ISO/TC 44/SC 6 via your national standards body. A complete listing of these bodies can be found at <http://www.iso.org>.

.....

Resistance welding — Welding current measurement for resistance welding —

Part 3: Current sensing coil

1 Scope

This part of ISO 17657 specifies current sensing coils of the toroidal-coil type as a current sensor for welding current meters or a welding current measuring system used to monitor the welding current in resistance welding, and is applicable for both current types, i.e. alternating current of 50 Hz or 60 Hz and direct current.

2 Normative references

The following referenced documents are indispensable for the application of this document. For dated references, only the edition cited applies. For undated references, the latest edition of the referenced document (including any amendments) applies.

ISO 669, *Resistance welding — Resistance welding equipment — Mechanical and electrical requirements*

ISO 17657-4, *Resistance welding — Welding current measurement for resistance welding — Part 4: Calibration system*

3 Terms and definitions

For the purposes of this document, the terms and definitions given in ISO 669 and the following apply.

3.1

current sensing coil (toroidal coil)

multi-wound coil, in which wire is wound around a non-magnetic core of constant cross-section, used for detecting the magnetic flux generated by current

NOTE The coil is mounted around or encircles a conductor through which the current to be measured passes.

3.2

reference current sensing coil

current sensing coil calibrated at a higher accuracy than the highly accurate class defined in this part of ISO 17657

3.3

conversion coefficient

ratio of output voltage from a current sensing coil against the welding current, expressed in millivolts per kiloamp (mV/kA)

NOTE The value is proportional to the frequency of the measured current, and is defined with a perfectly full-wave current of 50 Hz as the test current.

3.4 frequency response

feature indicating the influence of frequency of test current on the conversion coefficient

3.5 accuracy

scatter and deviation of the conversion coefficient

NOTE The output load of the current sensing coil strongly influences the value of the conversion coefficient. If the output load and/or input impedance of an integrator changes, the conversion coefficient may deviate even though both devices have been separately calibrated in a highly accurate class.

4 Physical environment and operating conditions

Unless otherwise specified, the current sensing coil shall be capable of operating under the following conditions:

- at an ambient air temperature between +5 °C and +40 °C;
- in relative humidity up to 95 %;
- at altitudes up to 1 000 m above mean sea level;
- where gas, fine dust, oil mist, spatters, etc. are included in the air such as those caused by ordinary arc or spot welding work.

When the operating conditions are not of any of those specified above, an agreement may be needed between the manufacturer and the purchaser.

5 Classification of current sensing coils and designation of product

5.1 Class of current sensing coils

The current sensing coils shall be classified depending on construction, conversion coefficient and measuring accuracy. Classifications by the accuracy are shown in Table 1.

Table 1 — Classification of current sensing coils

Classification	Measuring accuracy	Application
Highly accurate class	± 0,5 % of full scale	Laboratory use
Accurate class	± 1,0 % of full scale	Routine use for highly accurate systems
Ordinary class	± 3,0 % of full scale	Routine use for ordinary systems

5.2 Standard values of the conversion coefficient

Rated values of the standard conversion coefficient, *K*, shall be of 150 mV/kA, 220 mV/kA and 1,5 V/kA for full-wave alternating current of 50 Hz.

NOTE If a different test frequency is used for defining the conversion coefficient, the value can be converted by using equation (1) described in 7.1.

5.3 Designation of products

The following shall be indicated:

- design type as designated by type of construction;
- conversion coefficient;
- specified accuracy class;
- coil size (length for flexible type, and inner diameter for rigid type).

The designation of length can be omitted if the value is not needed.

EXAMPLE 1 Flexible type of 800 mm length, conversion coefficient of 150 mV/kA at 50 Hz, and accurate class.

Flexible (800 mm) 150 mV/kA, 50 Hz, class 1.0

EXAMPLE 2 Rigid type of 200 mm inner diameter, conversion coefficient of 180 mV/kA at 60 Hz, and highly accurate class.

Rigid (200 mm) 180 mV/kA, 60 Hz, class 0.5

6 Requirements for current sensing coils

6.1 Current sensing coil and connecting lead

The current sensing coil, connector and connecting lead from the coil to the integrator/amplifier shall be designed such that the coil is sensitive only to magnetic flux generated by current flow through the conductor within the coil. Any external magnetic flux across the coil is not measured. The output of the coil is proportional to a derivative of the measured current waveform.

If a flexible or rigid hatched-type coil is used, both ends of the sensing coil shall be fixed leaving little or no space between the ends. To avoid wave distortion, the connecting lead and connector should be protected from magnetic flux and should have low inductance.

A low inductive resistance shall be connected to the ends of the connecting lead as the output load, R_L . The value should be constant between 200 Ω and 1 k Ω .

6.2 Conversion coefficient

The rated conversion coefficient of current sensing coils should conform with those described in 5.2. The values shall be checked, and adjusted according to the method described in 7.1 using full-wave currents. The scatter of the conversion coefficient shall be checked using a reference current meter and data acquisition system, or a reference current sensing coil and a data acquisition system. The correction shall be performed by inserting a small resistance, r_a , in the end of coil or the end of connection lead as shown in Figure A.1. The coefficient value should not be adjusted by controlling the value of the output load R_L .

If the coils are checked with an alternating current of 60 Hz, the value shall be divided by 1,2 (= 60/50) to get the conversion coefficient in 50 Hz.

The input impedance of an integrator, connected to the current sensing coil, influences the value of conversion coefficient. The output voltage should be measured with a high-input impedance device larger than 500 k Ω as for the data acquisition system, with the output load specified in 6.1 connected if the coil does not include a resistor. The conversion coefficient values for an alternating current of 60 Hz can be checked and adjusted although the value is indicated in 50 Hz. In the case of an alternating current of 60 Hz, the conversion coefficient marked on the coil is calculated according to Equation (1) described in 7.1.

6.3 Measuring accuracy

The measuring accuracy of current sensing coils shall be one shown in Table 1, and shall be checked according to the method described in 7.2 using full-wave alternating currents of 50 Hz or 60 Hz.

NOTE Current sensing coils with a small deviation of less than 1 % can be manufactured, which meet the repeat bending requirements after 1 000 re-attachments, provided the current conductor is located at positions B, F or H, or near the position illustrated in Figure 1.

6.4 Mechanical strength

Mechanical tests shall be applied only to flexible coils. After using mechanical tests according to the methods described in 7.3.2 to 7.3.6 with full-wave alternating currents at 50 Hz or 60 Hz, the measuring accuracy of the tested coil shall comply with those shown in Table 1.

6.5 Setting position error

Scatters of the conversion coefficient for the test coil shall be checked according to the method described in 7.4 using full-wave alternating currents of 50 Hz or 60 Hz. The scatters and/or deviation shall be within the measuring accuracy stipulated in Table 1.

6.6 Influence of ambient temperature

The influence of ambient temperature on the current sensing coil shall be evaluated according to the method described in 7.5. The scatters and/or deviations of conversion coefficient shall be measured according to the method described in 7.2, and the values shall be within the measuring accuracy shown in Table 1.

6.7 Thermal property of cover materials

The cover of current sensing coils shall not be damaged by coming into contact with a wire heated to a temperature of 60 °C. If the current sensing coil is mounted within a transformer, the coil shall withstand temperatures according to the insulation class of the transformer.

6.8 Test

6.8.1 Type test

Some type tests shall be carried out on the same product according to Clause 5:

- a) construction;
- b) conversion coefficient test;
- c) measuring accuracy test;
- d) mechanical tests;
- e) positioning test;
- f) thermal test;
- g) contact test.

6.8.2 Acceptance test

- a) construction;
- b) conversion coefficient test.

7 Test procedures

7.1 Conversion coefficient

The conversion coefficient shall be measured with a reference welding current measuring system, or with a reference current sensing coil combined with a data acquisition system in accordance with ISO 17657-4. The value shall be adjusted by an appropriate procedure.

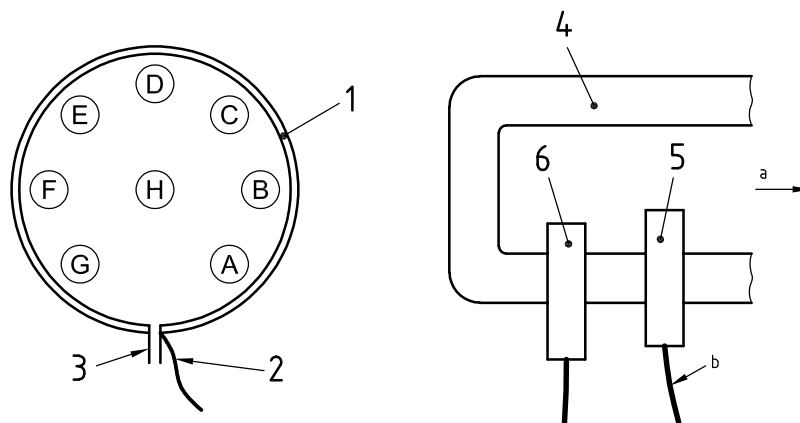

Key

- | | | | |
|---|--|--------|----------------------|
| 1 | test coil | 4 | conductor |
| 2 | lead cable | 5 | reference coil |
| 3 | fixing of flexible coil – output connector of rigid coil | 6 | test coil |
| | | A to H | Conductor positions. |
| a | To power source. | | |
| b | To reference welding current meter. | | |

Figure 1 — Examples of the arrangement of a current sensing coil and their position numbers

The test should be carried out at position of B, D, F and H shown in Figure 1 with full-wave alternating currents of 50 Hz or 60 Hz, and within the range 5 kA to 10 kA. Then the measured result shall be indicated by a value indicated for 50 Hz.

The reference welding current meter, reference current sensing coil, and a data acquisition system shall be calibrated at least every year in accordance with ISO 17657-4.

If the current frequency used for the test differs from 50 Hz, the value shall be converted using Equation (1); e.g. when the coefficient is defined with a current of 60 Hz, the standard value should be converted to a value described for 60 Hz by Equation (1), then adjusted. The detail regarding the converting is explained in Annex B.

$$K_t = K_m \times \frac{f_t}{f_m} \quad (1)$$

where

K_t is the conversion coefficient value at frequency f_t ;

K_m is the conversion coefficient measured with an alternating current of 50 Hz or 60 Hz;

f_t is the frequency to estimate the conversion coefficient K_t ;

f_m is the frequency when the conversion coefficient is defined (50 Hz or 60 Hz).

7.2 Measuring accuracy

The scatter in the conversion coefficient shall be checked using a reference current measuring system, or with a reference current sensing coil combined with a data acquisition system in accordance with ISO 17657-4. A full-wave alternating current of 50 Hz or 60 Hz shall be used. If the maximum scatter does not comply with the specified accuracy, the conversion coefficient shall be readjusted, and the test repeated. The tests shall be performed at positions B, D, F and H shown in Figure 1 with current levels between 5 kA and 10 kA, and/or between 0,5 kA and 1,0 kA.

The high current test is targeted for current sensing coils used to measure the secondary circuit current, while the low current test is designed for primary circuit current measurement.

NOTE The number of test positions can be reduced by agreement between the contracting parties.

7.3 Mechanical tests

7.3.1 General

The following test procedures shall be used for assessing the mechanical properties of current sensing coils of the flexible type.

After each type of mechanical test, the measuring accuracy of current sensing coil shall be checked using the method described in 7.2.

7.3.2 Tension test

After a current sensing coil is straightened, one end is fixed, and a 100 N load is applied to the other end for one hour as shown in Figure 2.

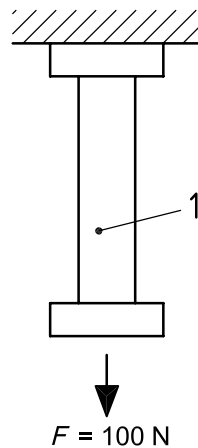

Key

1 current sensing coil

Figure 2 — Tension test

7.3.3 Pressure test

The current sensing coil is straightened, placed flat on an even surface and loaded with an evenly distributed pressure of 5 N/cm² except on the coupling. The pressure is maintained for 1 h, as shown in Figure 3.

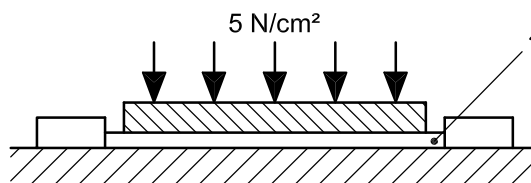

Key

1 current sensing coil

Figure 3 — Compression test

7.3.4 Bend test

The middle part of an open current sensing coil is bent through an angle of 180° with a certain radius and maintained for one hour as shown in Figure 4. The bending radius shall be 50 % of the inner radius of the closed coil, but not less than 25 mm.

Dimensions in millimetres

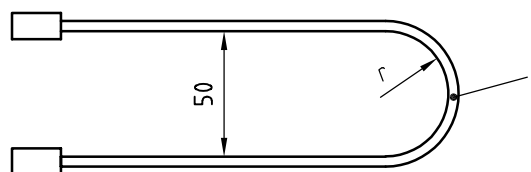

Key

1 current sensing coil

Figure 4 — Bend test and repeat bend test

7.3.5 Repeat bend test

The middle part of an open current sensing coil is bent through an angle of 180° with a certain radius for 1 000 repetitions, see Figure 4. The bending radius shall be 50 % of the inner radius of the closed coil, but not less than 25 mm.

7.3.6 Crush test

A closed current sensing coil is placed as a ring, flat on an even surface, and loaded with an evenly distributed pressure of 2 N/cm² across the whole coil surface except on the coupling, for 1 h, as shown in Figure 5.



Key

1 current sensing coil

Figure 5 — Crush test

7.4 Setting position error test

Positional errors shall be checked at all positions, i.e., A to H shown in Figure 1 in order to determine the deviation for the conversion coefficient values indicated by the coil. Three separate measurements as stipulated in 7.2 shall be made for the eight positions illustrated in Figure 1.

NOTE If the setting position of a coil is fixed only at the position H in Figure 1, this test should not be applied for the rigid coil.

7.5 Thermal test

Three tests as described in 7.2 shall be carried out after maintaining the current sensing coil in a temperature-controlled oven for one hour until the coil temperature reaches test temperatures. The thermal tests shall be carried out at +5 °C and +40 °C, and be completed within 3 min of removal of the current sensing coil from the oven.

NOTE If the current sensing coil is mounted within a transformer, the maximum test temperature may be modified, and agreed upon between the manufacturer and the purchaser.

7.6 Contact test

The contact test shall be carried out by placing the test coil in contact with a copper plate heated at a temperature of 60 °C, and loaded to 10 N. The load shall be maintained for 1 h. At the end of the test, the cover shall not be damaged.

8 Marking

Current sensing coils shall be marked with the following indications:

- a) name of the current sensing coil;
- b) conversion coefficient of the current sensing coil, in millivolts per kiloamp (mV/kA);
- c) measuring accuracy of the coil, in percent (%);
- d) output load of the current sensing coil, R_L , in ohms (Ω).

The current sensing coil shall be marked with “+” on one surface so that, when this is on top after installation into the secondary circuit of the welding equipment (in direct current welding machines pointing towards the positive electrode), a positive indicating value is depicted by the measuring instrument.

Annex A (informative)

Design of current sensing coils

A.1 Construction of current sensing coils

The current sensing coil of the Rogowski type, known as a toroidal coil, should be made by uniformly close winding wire around a non-inductive core of uniform cross-section along its length as shown in Figure A.1. The ends of the coil should be in close contact with each other. The coil should be covered with an insulated metal film to protect it against any external electric field. Self-inductance, L , and internal resistance, r_i , of the coil should be as low as possible.

The connecting lead should be twisted and shielded by means of an adequate method. A low inductive resistance, R_L , shall be connected to the connecting lead in the output connector in order to guarantee compatibility between coils.

To make the output voltage $e'(t)$ independent of both the coil position and of external fields, the following conditions shall be fulfilled:

- cross-section, A , of a small loop in Figure A.1 a) and winding density, N , are constant along the length of coil;
- area of the individual windings are perpendicular to the axis of coil;
- sufficiently large winding density, N , and small winding wire diameter;
- wire shall be wound as homogeneous as possible in the area of coupling and lead connection.

NOTE The connection part of both ends of coil should be located as far from the current conductor as possible to prevent any measuring errors.

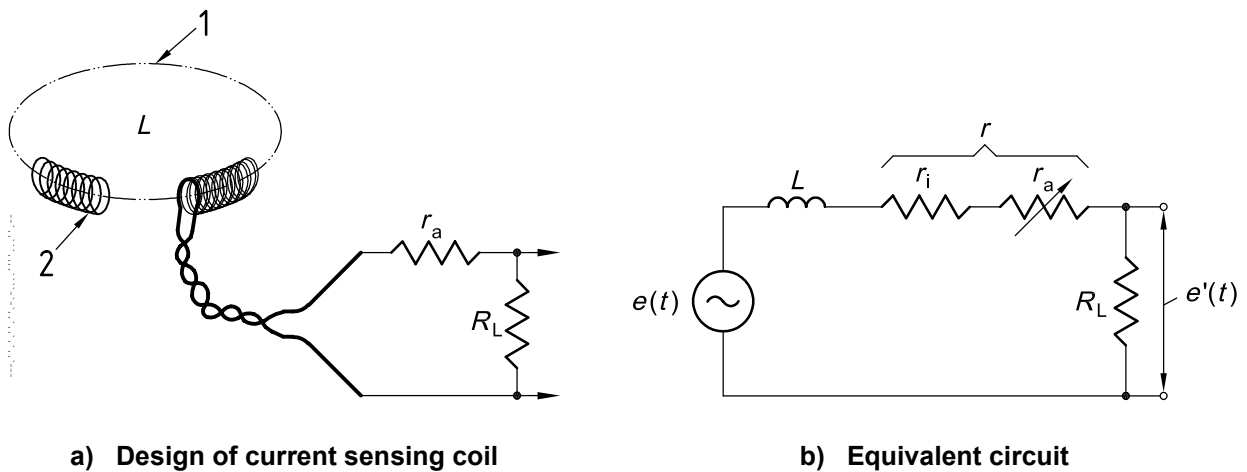

- Key**
- 1 large loop
 - 2 small loop

Figure A.1 — Current sensing coil of Rogowski type and its equivalent circuit

The above Rogowski-type coil is designed with return winding to cancel the voltage induced by the large loop coil. The Rogowski-type coil has the merit that any external magnetic flux across the large loop coil does not affect on the output voltage, and only relates to the magnetic fluxes across the small loop coils.

However, current sensing coils without any return windings as shown in Figure A.2 are also known as toroidal coils, in which external magnetic flux across the large loop coil affects on the output from the coil. This type should only be used as the current sensor if the intended use meets the following limitations:

- a) the coil is used in a fixed position at a right angle (90°) to the current conductor;
- b) induced voltage by external magnetic flux across the large loop of toroidal coil is negligible when compared to the measured output value, and area of the large loop is as reduced as possible.

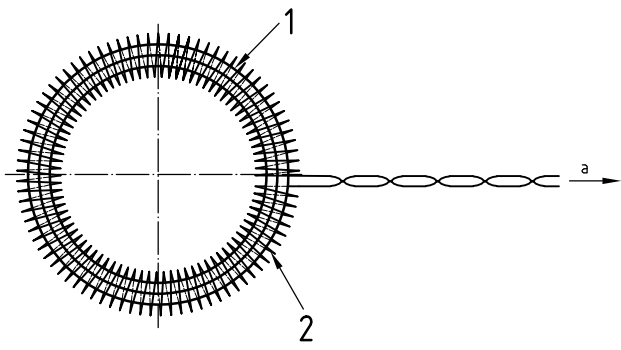

- Key**
- 1 large loop
 - 2 small loop
 - a To integrator.

Figure A.2 — A toroidal coil without return winding

A.2 Adjustment of the conversion coefficient

Adjustment of the conversion coefficient of the test current sensing coil should be conducted with a correction index Δr_a calculated by the following equation:

$$\Delta r_a = \left(\frac{K_m}{K_s} - 1 \right) \times (R_L + r) \quad (\text{A.1})$$

where

K_m is the measured conversion coefficient;

K_s is the required value;

R_L is the output load mounted at the end of connecting lead;

r is the internal resistance defined by a sum of the internal resistance, r_i , of current sensing coil and an additional resistance to adjust the output value, r_a .

Each parameter is defined in Figure A.1.

The measuring accuracy of the test coil should be determined after this adjustment and re-tested to determine the conversion coefficient by means of both the setting position error test and thermal test as described in 7.4 and 7.5 respectively.

Annex B (informative)

Governing parameters of the conversion coefficient

The output voltage; $e'(t)$ from the current sensing coil shown in Figure A.1 can be described by means of Equation (B.1) on condition that $\omega L \ll R_L + r_i$ and $R_L \ll R_f$.

$$\int_0^t e'(t) dt = \frac{R_L}{R_L + r} NA\mu_0 I(t) \quad (\text{B.1})$$

If the current waveform is a sinusoidal curve, $I = I_m \sin \omega t$, the conversion coefficient, K , for the full-wave alternating current can be defined by Equation (B.2):

$$K = \frac{R_L}{R_L + r} NA\mu_0 \omega \quad (\text{V/A}) \quad (\text{B.2})$$

where

- μ_0 is the permeability of the core materials used for the current sensing coil [= $4\pi \times 10^{-7}$ H/m (henry per metre)];
- N is the number of coil windings per unit length (1/m);
- A is the cross-section of the current sensing coil (not for loop length of the current sensing coil), in square metres (m²);
- L is the self-inductance of the current sensing coil, in henry (H);
- r is the sum of resistance of current sensing coil r_i and a small adjustment resistance, r_a , in ohms (Ω);
- R_L is the resistance connected at the sensing coil ends as a output load/burden (hereafter referred to as the "output load" of the current sensing coil), in ohms (Ω);
- $\omega = 2\pi f$ is the angular frequency;
- f is the frequency of target (measured) current, in hertz (Hz);
- R_f is the input resistance of an integrator, in ohms (Ω).

When the condition $R_L \ll R_f$ cannot be satisfied, the value; R_L should be replaced with the following value:

$$R_L \rightarrow \frac{R_L \times R_f}{R_L + R_f} \quad (\text{B.3})$$

NOTE The conversion coefficient is only the rated value, because the welding current wave is not truly sinusoidal, and the value changes with the frequency spectrum of the current.

Annex C (informative)

Type of current sensing coils and their recommended specification range

Typical designs of current sensing coils are illustrated in Figure C.1.

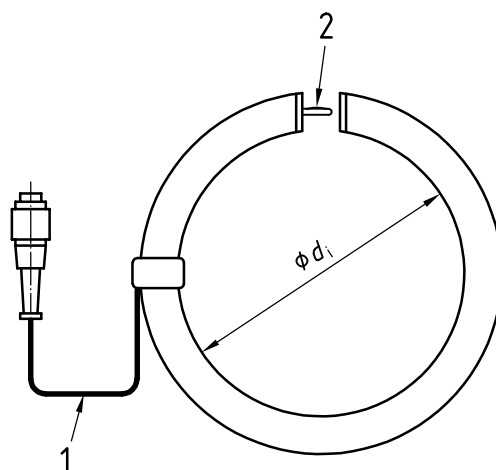

Key

- 1 connecting cable
- 2 fixing

a) Flexible coil (with fixing)

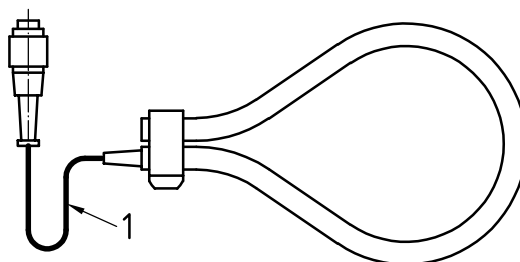

Key

- 1 connecting cable

b) Flexible coil (without fixing)

Figure C.1 — Examples of current sensing coils

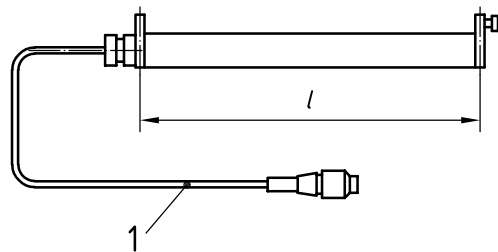

Key

1 connecting cable

c) Flexible coil

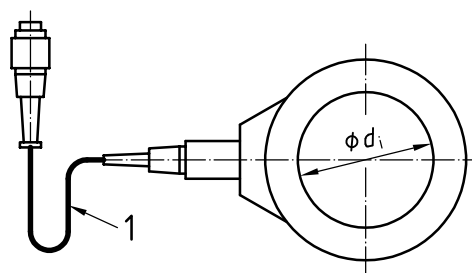

Key

1 connecting cable

d) Rigid coil (closed type)

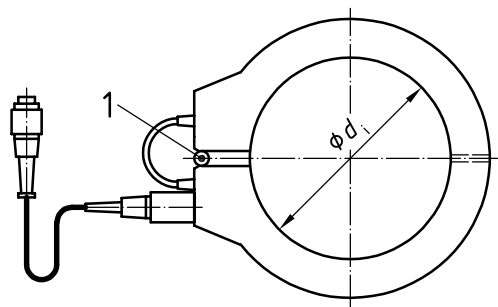

Key

1 hinge

e) Rigid coil (hinged type)

Figure C.1 (continued)

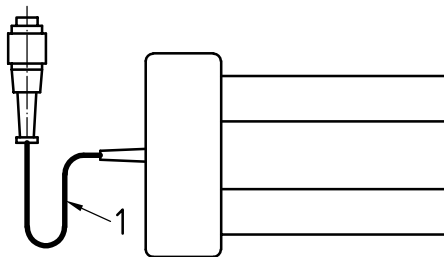

Key

1 connecting cable

f) Rigid open frame fork without bridge

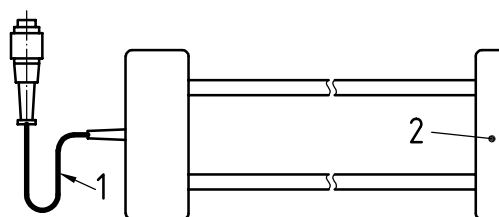

Key

1 connecting cable

2 bridge

g) Rigid closed frame with bridge

Figure C.1 (continued)

Dimensional ranges and recommended specification for the design of current sensing coils in practice are

$L \approx 200 \mu\text{H}$ to $2\,000 \mu\text{H}$;

$r_i \approx 10 \Omega$ to 300Ω ;

$M \approx 0,3 \mu\text{H}$ to $7 \mu\text{H}$ ($M = NA\mu_0$);

$K \approx 100 \text{ mV/kA}$ to $2\,500 \text{ mV/kA}$ (for full-wave alternating current of 50 Hz);

$R_L \approx 200 \Omega$ to $1\,000 \Omega$;

$d_i \approx 20 \text{ mm}$ to 300 mm (current sensing coils, frame forks; see Figure C.1);

l up to 800 mm [straightened length of the belts; see Figure C.1 c)].

where

L is the self-inductance of current sensing coil;

r_i is the resistance of the coil;

M is the mutual inductance of the coil;

K is the rated conversion coefficient of the coil;

R_L is the output load pre-mounted in the coil;

d_i is the coil diameter defined with inner diameter shown in Figure C.1 a), d) and e);

l is the straightened length of the belt type coil shown in Figure C.1 c).

Annex D (informative)

Frequency response of current sensing coils

Frequency response F of the current sensing coils can be defined by Equation (D.1) if the internal resistance, r_i , is negligible:

$$F = 1 - \frac{j\omega L}{R_L} \quad (\text{D.1})$$

where

$$j = \sqrt{-1}$$

Then, the phase shift angle, α , of the output voltage, $e'(t)$, of the current sensing coil against the generated voltage $e(t)$ ($\infty di/dt$; i : current) caused by fluctuating magnetic flux can be indicated using Equation (D.2):

$$\alpha = -\tan^{-1}\left(\frac{\omega L}{R_L}\right) \quad (\text{D.2})$$

The magnitude of the output voltage from the current sensing coil can be expressed by the following equation:

$$\frac{|e'|}{|e|} = \frac{R_L}{\sqrt{(\omega L)^2 + R_L^2}} \quad (\text{D.3})$$

ICS 25.160.10

Price based on 17 pages