**Non-destructive testing of welds —
Ultrasonic testing — Techniques, testing
levels, and assessment**

*Contrôle non destructif des assemblages soudés — Contrôle par
ultrasons — Techniques, niveaux d'essai et évaluation*



PDF disclaimer

This PDF file may contain embedded typefaces. In accordance with Adobe's licensing policy, this file may be printed or viewed but shall not be edited unless the typefaces which are embedded are licensed to and installed on the computer performing the editing. In downloading this file, parties accept therein the responsibility of not infringing Adobe's licensing policy. The ISO Central Secretariat accepts no liability in this area.

Adobe is a trademark of Adobe Systems Incorporated.

Details of the software products used to create this PDF file can be found in the General Info relative to the file; the PDF-creation parameters were optimized for printing. Every care has been taken to ensure that the file is suitable for use by ISO member bodies. In the unlikely event that a problem relating to it is found, please inform the Central Secretariat at the address given below.



COPYRIGHT PROTECTED DOCUMENT

© ISO 2010

All rights reserved. Unless otherwise specified, no part of this publication may be reproduced or utilized in any form or by any means, electronic or mechanical, including photocopying and microfilm, without permission in writing from either ISO at the address below or ISO's member body in the country of the requester.

ISO copyright office
Case postale 56 • CH-1211 Geneva 20
Tel. + 41 22 749 01 11
Fax + 41 22 749 09 47
E-mail copyright@iso.org
Web www.iso.org

Published in Switzerland

Contents

Page

Foreword	iv
1 Scope	1
2 Normative references	1
3 Symbols and definitions	2
4 Principle	2
5 Information required prior to testing	3
5.1 Items to be specified	3
5.2 Specific information required before testing	3
5.3 Written test procedure	4
6 Requirements for personnel and equipment	4
6.1 Personnel qualifications	4
6.2 Equipment	4
6.3 Probe parameters	4
7 Testing volume	5
8 Preparation of scanning surfaces	5
9 Parent metal testing	6
10 Range and sensitivity setting	7
10.1 General	7
10.2 Reference for sensitivity setting	7
10.3 Evaluation levels	8
10.4 Transfer correction	8
10.5 Signal to noise ratio	8
11 Testing levels	9
12 Testing techniques	9
12.1 General	9
12.2 Manual scan path	9
12.3 Testing for imperfections perpendicular to the testing surface	9
12.4 Location of indications	9
12.5 Evaluation of indications	10
13 Test report	11
Annex A (normative) Testing levels for various types of welded joints	13

Foreword

ISO (the International Organization for Standardization) is a worldwide federation of national standards bodies (ISO member bodies). The work of preparing International Standards is normally carried out through ISO technical committees. Each member body interested in a subject for which a technical committee has been established has the right to be represented on that committee. International organizations, governmental and non-governmental, in liaison with ISO, also take part in the work. ISO collaborates closely with the International Electrotechnical Commission (IEC) on all matters of electrotechnical standardization.

International Standards are drafted in accordance with the rules given in the ISO/IEC Directives, Part 2.

The main task of technical committees is to prepare International Standards. Draft International Standards adopted by the technical committees are circulated to the member bodies for voting. Publication as an International Standard requires approval by at least 75 % of the member bodies casting a vote.

Attention is drawn to the possibility that some of the elements of this document may be the subject of patent rights. ISO shall not be held responsible for identifying any or all such patent rights.

ISO 17640 was prepared by the European Committee for Standardization (CEN) Technical Committee TC 121, *Welding*, Subcommittee SC 5, *Testing of welds*, in collaboration with ISO Technical Committee TC 44, *Welding and allied processes*, Subcommittee SC 5, *Testing and inspection of welds*, in accordance with the Agreement on technical cooperation between ISO and CEN (Vienna Agreement).

This second edition cancels and replaces the first edition (ISO 17640:2005), which has been technically revised.

Requests for official interpretations of any aspect of this International Standard should be directed to the Secretariat of ISO/TC 44/SC 5 via your national standards body. A complete listing of these bodies can be found at www.iso.org.

Non-destructive testing of welds — Ultrasonic testing — Techniques, testing levels, and assessment

1 Scope

This International Standard specifies techniques for the manual ultrasonic testing of fusion-welded joints in metallic materials of thickness greater than or equal to 8 mm which exhibit low ultrasonic attenuation (especially that due to scatter) at object temperatures from 0 °C to 60 °C. It is primarily intended for use on full penetration welded joints where both the welded and parent material are ferritic.

Where material-dependent ultrasonic values are specified in this International Standard, they are based on steels having an ultrasonic sound velocity of $(5\,920 \pm 50)$ m/s for longitudinal waves and $(3\,255 \pm 30)$ m/s for transverse waves.

This International Standard specifies four testing levels, each corresponding to a different probability of detection of imperfections. Guidance on the selection of testing levels A, B, and C is given in Annex A.

This International Standard specifies that the requirements of testing level D, which is intended for special applications, be in accordance with general requirements. Testing level D can only be used when defined by specification. This includes tests of metals other than ferritic steel, tests on partial penetration welds, tests with automated equipment, and tests at object temperatures outside the range 0 °C to 60 °C.

This International Standard can be used for the assessment of indications, for acceptance purposes, by either of the following techniques:

- a) evaluation based primarily on length and echo amplitude of the signal indication;
- b) evaluation based on characterization and sizing of the indication by probe movement techniques.

The techniques used shall be specified.

2 Normative references

The following referenced documents are indispensable for the application of this document. For dated references, only the edition cited applies. For undated references, the latest edition of the referenced document (including any amendments) applies.

ISO 5817, *Welding — Fusion-welded joints in steel, nickel, titanium and their alloys (beam welding excluded) — Quality levels for imperfections*

ISO 9712, *Non-destructive testing — Qualification and certification of personnel*

ISO 11666:2010, *Non-destructive testing of welds — Ultrasonic testing of welded joints — Acceptance levels*

ISO 23279, *Non-destructive testing of welds — Ultrasonic testing — Characterization of indications in welds*

ISO 17635, *Non-destructive testing of welds — General rules for metallic materials*

EN 473, *Non-destructive testing — Qualification and certification of NDT personnel — General principles*

EN 583-1, *Non-destructive testing — Ultrasonic examination — Part 1: General principles*

EN 583-2, *Non-destructive testing — Ultrasonic examination — Part 2: Sensitivity and range setting*

EN 583-4, *Non-destructive testing — Ultrasonic examination — Part 4: Examination for discontinuities perpendicular to the surface*

EN 1330-4, *Non-destructive testing — Terminology — Part 4: Terms used in ultrasonic testing*

EN 12668 (all parts), *Non-destructive testing — Characterization and verification of ultrasonic examination equipment*

3 Symbols and definitions

3.1 For the purposes of this International Standard, the definitions given in EN 1330-4 and ISO 17635 apply.

3.2 For symbols, their definitions, and units, see Table 1.

Indications shall be considered to be either longitudinal or transverse, depending on the direction of their major dimension with respect to the weld axis, x , in accordance with Figure 2.

Table 1 — Symbols, their definitions, and units

Symbol	Definition	Unit
D_{DSR}	diameter of the disk-shaped reflector	mm
h	extension of the indication in depth direction	mm
l	length of the indication	mm
l_x	projected length of the indication in the x -direction	mm
l_y	projected length of the indication in the y -direction	mm
p	full skip distance	mm
t	thickness of parent material (thinnest part)	mm
x	position of the indication in the longitudinal direction	mm
y	position of the indication in the transverse direction	mm
z	position of the indication in depth	mm

4 Principle

The purpose of this International Standard is to describe general techniques of ultrasonic weld testing, using standard criteria, for the most commonly used welded joints at object temperatures in the range 0 °C to 60 °C. The specific requirements of this International Standard cover the equipment, preparation, performance of the testing, and reporting. The parameters specified, in particular those for the probes, are compatible with the requirements of ISO 11666 and ISO 23279.

5 Information required prior to testing

5.1 Items to be specified

These include:

- a) method for setting the reference level;
- b) method to be used for evaluation of indications;
- c) acceptance levels;
- d) testing level;
- e) manufacturing and operation stage(s) at which the testing is to be carried out;
- f) qualification of personnel;
- g) extent of the testing for transverse indications;
- h) requirements for additional tandem testing (see EN 583-4);
- i) parent metal testing prior to and/or after welding;
- j) whether or not a written testing procedure is required;
- k) requirements for written testing procedures.

5.2 Specific information required before testing

Before any testing of a welded joint can begin, the operator shall have access to the following essential information:

- a) written testing procedure, if required (see 5.3);
- b) type(s) of parent material and product form (i.e. cast, forged, rolled);
- c) manufacturing or operation stage at which testing is to be made, including heat treatment, if any;
- d) time and extent of any post-weld heat treatment;
- e) joint preparation and dimensions;
- f) requirements for surface conditions;
- g) welding procedure or relevant information on the welding process;
- h) reporting requirements;
- i) acceptance levels;
- j) extent of testing, including requirements for transverse indications, if relevant;
- k) testing level;
- l) personnel qualification level;
- m) procedures for corrective actions when unacceptable indications are revealed.

5.3 Written test procedure

The definitions and requirements in this International Standard normally satisfy the need for a written test procedure.

Where this is not the case, or where the techniques described in this International Standard are not applicable to the weld joint to be examined, additional written test procedures shall be used, if required by specification.

6 Requirements for personnel and equipment

6.1 Personnel qualifications

Personnel performing testing in accordance with this International Standard shall be qualified to an appropriate level in ultrasonic testing in accordance with ISO 9712 or EN 473 or equivalent in the relevant industrial sector.

In addition to a general knowledge of ultrasonic weld inspection, personnel shall also be familiar with testing problems specifically associated with the type of weld joints to be examined.

6.2 Equipment

Any equipment used for testing in conjunction with this International Standard shall comply with the requirements of EN 12668 (all parts).

6.3 Probe parameters

6.3.1 Test frequency

The frequency shall be within the range 2 MHz to 5 MHz, and shall be selected to comply with the specified acceptance levels.

For the initial testing, the frequency shall be as low as possible, within the above range, when the evaluation is carried out according to acceptance levels based on length and amplitude, e.g. ISO 11666. Higher frequencies may be used to improve range resolution if this is necessary when using standards for acceptance levels based on characterization of indications, e.g. ISO 23279.

Frequencies of approximately 1 MHz may be used for testing at long sound paths where the material shows above average attenuation.

6.3.2 Angles of incidence

When testing is carried out with transverse waves and techniques that require the ultrasonic beam to be reflected from an opposite surface, care shall be taken to ensure that the angle between the beam and the normal to the opposite reflecting surface is between 35° and 70°. Where more than one probe angle is used, at least one of the angle probes used shall conform with this requirement. One of the probe angles used shall ensure that the weld fusion faces are examined at, or as near as possible to, normal incidence. When the use of two or more probe angles is specified, the difference between the nominal beam angles shall be 10° or greater.

Angles of incidence at the probe and opposite reflecting surface, when curved, may be determined by drawing a sectional view of the weld or in accordance with the techniques given in EN 583-2. Where angles of incidence cannot be determined as specified by this International Standard, the testing report shall contain a comprehensive description of the scans used and the extent of any incomplete coverage caused, together with an explanation of the difficulties encountered.

6.3.3 Element size

The element size shall be chosen according to the ultrasonic path to be used and the frequency.

The smaller the element, the smaller the length and width of the near field, and the larger the beam spread in the far field at a given frequency.

Small probes having 6 mm to 12 mm diameter elements (or rectangular elements of equivalent area) are therefore most useful when working at short beam path ranges. For longer ranges, i.e. greater than 100 mm for single normal beam probes and greater than 200 mm for angle beam probes, an element size of 12 mm to 24 mm is more suitable.

6.3.4 Adaptation of probes to curved scanning surfaces

The gap, g , between test surface and bottom of the probe shoe shall not be greater than 0,5 mm.

For cylindrical or spherical surfaces, this requirement can be checked with Equation (1):

$$g = \frac{a^2}{D} \quad (1)$$

where

a is the dimension, in millimetres, of the probe shoe in the direction of testing;

D is the diameter, in millimetres, of the component.

If a value for g larger than 0,5 mm results from the equation, the probe shoe shall be adapted to the surface and the sensitivity and range shall be set accordingly.

6.3.5 Coupling media

The coupling media shall be in accordance with EN 583-1. The coupling medium used for range and sensitivity setting and for the test shall be the same.

7 Testing volume

The testing volume (see Figure 1) is defined as the zone which includes weld and parent material for at least 10 mm on each side of the weld, or the width of the heat-affected zone, whichever is greater.

In all cases, scanning shall cover the whole testing volume. If individual sections of this volume cannot be covered in at least one scanning direction, or if the angles of incidence with the opposite surface do not meet the requirements of 6.3.2, alternative or supplementary ultrasonic techniques or other non-destructive techniques shall be agreed upon. This may, in some cases, require removal of the weld reinforcement.

Supplementary techniques may require testing using dual element angle beam probes, creeping wave probes, further ultrasonic techniques or any other suitable method, e.g. liquid penetrant, magnetic particle, radiographic testing. In selecting alternative or supplementary techniques, due consideration should be given to the type of weld and probable orientation of any imperfections to be detected.

8 Preparation of scanning surfaces

Scanning surfaces shall be wide enough to permit the testing volume (see Figure 1) to be fully covered. Alternatively, the width of the scanning surfaces may be smaller if equivalent coverage of the testing volume can be achieved by scanning from both the upper and the lower surface of the joint.

Scanning surfaces shall be even and free from foreign matter likely to interfere with probe coupling (e.g. rust, loose scale, weld spatter, notches, grooves). Waviness of the test surface shall not result in a gap between the probe and test surfaces greater than 0,5 mm. These requirements shall be ensured by dressing if necessary. Local variations in surface contour, e.g. along the edge of the weld, which result in a gap beneath the probe of up to 1 mm, can only be permitted if at least one additional probe angle is employed from the affected side at the weld. This additional scanning is necessary to compensate for the reduced weld coverage that will occur with a gap of this dimension.

Scanning surfaces and surfaces from which the sound beam is reflected shall allow undisturbed coupling and reflection.

9 Parent metal testing

The parent metal, in the scanning zone area (see Figure 1), shall be examined with straight beam probes prior to or after welding, unless it can be demonstrated (e.g. previous testing during the fabrication process) that the angle probe testing of the weld is not influenced by the presence of the imperfections or high attenuation.

Where imperfections are found, their influence on the proposed angle beam testing shall be assessed and, if necessary, the techniques adjusted correspondingly. When satisfactory coverage by ultrasonic testing is seriously affected, other inspection techniques (e.g. radiography) shall be considered.

Dimensions in millimetres

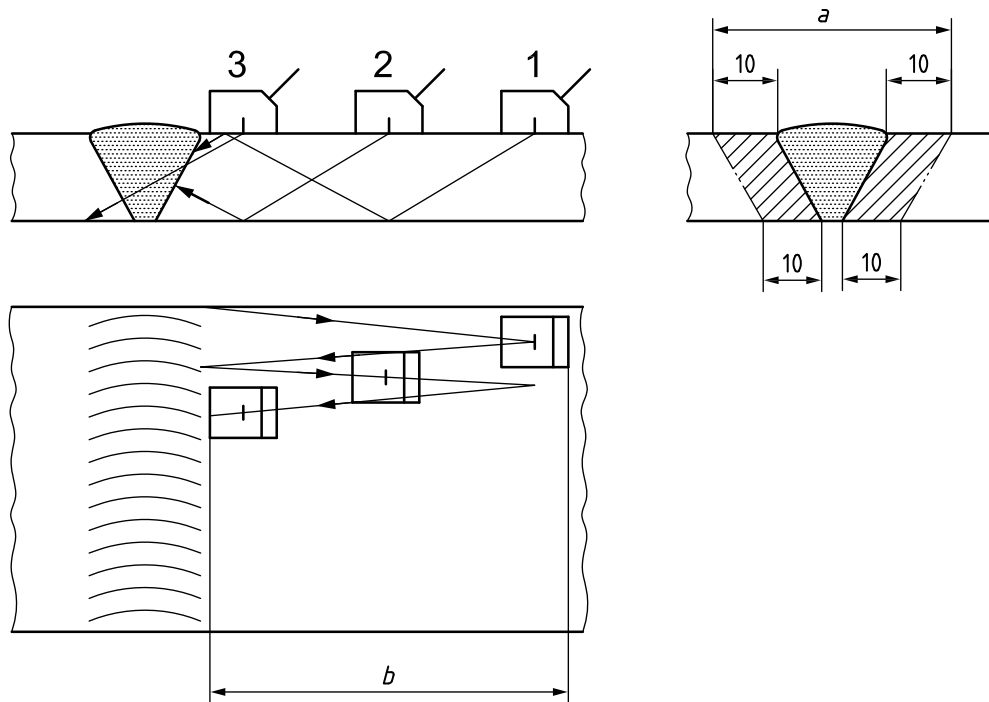

- Key**
- 1 position 1
 - 2 position 2
 - 3 position 3
 - a* width of testing volume
 - b* scanning zone width

Figure 1 — Example of testing volume to be covered when scanning for longitudinal indications

10 Range and sensitivity setting

10.1 General

Setting of range and sensitivity shall be carried out prior to each testing in accordance with this International Standard and EN 583-2, taking the influence of temperature into account. The temperature difference during range and sensitivity setting and during the test shall be within ± 15 °C.

Checks to confirm these settings shall be performed at least every 4 h and on completion of the testing. Checks shall also be carried out whenever a system parameter is changed or changes in the equivalent settings are suspected.

If deviations are found during these checks, the corrections given in Table 2 shall be carried out.

Table 2 — Sensitivity and range corrections

Sensitivity		
1	Deviations ≤ 4 dB	Setting shall be corrected before the testing is continued.
2	Reduction of the sensitivity > 4 dB	Setting shall be corrected and all testing carried out with the equipment over the previous period shall be repeated.
3	Increase in sensitivity > 4 dB	Setting shall be corrected and all recorded indications shall be re-examined.
Range		
1	Deviations ≤ 2 % of the range	Setting shall be corrected before testing is continued.
2	Deviations > 2 % of the range	Setting shall be corrected and testing carried out with the equipment over the previous period shall be repeated.

10.2 Reference for sensitivity setting

One of the following techniques for setting the reference shall be used.

- a) Technique 1: the reference is a distance-amplitude curve (DAC) for side-drilled holes of diameter 3 mm.
- b) Technique 2: the references for transverse and longitudinal waves using the distance gain size (DGS) system based on the diameter of the disk-shaped reflector (DSR) are given in Tables 3 and 4 respectively.
- c) Technique 3: the reference notch shall be 1 mm wide, rectangular, with a depth of 1 mm. This technique applies only for the thickness range $8 \text{ mm} \leq t < 15 \text{ mm}$ and for beam angles $\geq 70^\circ$.
- d) Technique 4: for the tandem technique, the reference is a flat bottomed hole of 6 mm diameter (for all thicknesses), perpendicular to the scanning surface. This technique is applicable only for beam angle 45° and thickness $t \geq 15 \text{ mm}$.

The length of the side-drilled holes and notches shall be greater than the width of the sound beam measured at -20 dB.

Table 3 — Reference levels for acceptance levels 2 and 3 for technique 2 using angle beam scanning with transverse waves

Nominal probe frequency MHz	Thickness of parent material, <i>t</i>					
	8 mm ≤ <i>t</i> < 15 mm		15 mm ≤ <i>t</i> < 40 mm		40 mm ≤ <i>t</i> < 100 mm	
	AL 2	AL 3	AL 2	AL 3	AL 2	AL 3
1,5 to 2,5	—	—	$D_{DSR} = 2,5$ mm	$D_{DSR} = 2,5$ mm	$D_{DSR} = 3,0$ mm	$D_{DSR} = 3,0$ mm
3,0 to 5,0	$D_{DSR} = 1,5$ mm	$D_{DSR} = 1,5$ mm	$D_{DSR} = 2,0$ mm	$D_{DSR} = 2,0$ mm	$D_{DSR} = 3,0$ mm	$D_{DSR} = 3,0$ mm

D_{DSR} is the diameter of the disk-shaped reflector.

Table 4 — Reference levels for acceptance levels 2 and 3 for technique 2 using straight beam scanning with longitudinal waves

Nominal probe frequency MHz	Thickness of parent material, <i>t</i>					
	8 mm ≤ <i>t</i> < 15 mm		15 mm ≤ <i>t</i> < 40 mm		40 mm ≤ <i>t</i> < 100 mm	
	AL 2	AL 3	AL 2	AL 3	AL 2	AL 3
1,5 to 2,5	—	—	$D_{DSR} = 2,5$ mm	$D_{DSR} = 2,5$ mm	$D_{DSR} = 3,0$ mm	$D_{DSR} = 3,0$ mm
3,0 to 5,0	$D_{DSR} = 2,0$ mm	$D_{DSR} = 2,0$ mm	$D_{DSR} = 2,0$ mm	$D_{DSR} = 2,0$ mm	$D_{DSR} = 3,0$ mm	$D_{DSR} = 3,0$ mm

D_{DSR} is the diameter of the disk-shaped reflector.

10.3 Evaluation levels

All indications equal to or exceeding the following shall be evaluated.

The evaluation levels for techniques 1 to 4 are given in ISO 11666:2010, Table A.1.

10.4 Transfer correction

When separate blocks are used for establishing reference levels, a measurement shall be made of the transfer differences, between test object and block, at a representative number of locations. Suitable techniques are described in EN 583-2.

If the differences are less than 2 dB, correction is not required.

If the differences are greater than 2 dB but smaller than 12 dB, they shall be compensated for.

If transfer losses exceed 12 dB, the reason shall be considered and further preparation of the scanning surfaces shall be carried out, if applicable.

When there are no apparent reasons for high correction values, the attenuation, at various locations on the test object, shall be measured and, where it is found to vary significantly, corrective actions shall be considered.

10.5 Signal to noise ratio

During testing of the weld, the noise level, excluding spurious surface indications, shall remain at least 12 dB below the evaluation level. This requirement may be relaxed subject to specification.

11 Testing levels

Quality requirements for welded joints are mainly associated with the material, welding process and service conditions. To accommodate all of these requirements, this International Standard specifies four testing levels (A, B, C, and D).

From testing level A to testing level C, an increasing probability of detection is achieved by an increasing testing coverage, e.g. number of scans, surface dressing. Testing level D may be agreed for special application using a written procedure which shall take into account the general requirements of this International Standard.

In general, the testing levels are related to quality levels (e.g. ISO 5817). The appropriate testing level may be specified by standards for testing of welds (e.g. ISO 17635), product standards or other documents.

When ISO 17635 is specified, the recommended testing levels are as given in Table 5.

Table 5 — Recommended testing levels

Testing level	Quality level in ISO 5817
A	C, D
B	B
C	by agreement
D	special application

Specific requirements for testing levels A to C are given for various types of joints in Annex A. The joint types shown are ideal examples only; where actual weld conditions or accessibility do not conform exactly with those shown, the testing technique shall be modified to satisfy the general requirements of this International Standard and the specific testing level required. For these cases, a written test procedure shall be prepared.

12 Testing techniques

12.1 General

Ultrasonic testing shall be performed in accordance with EN 583-1 with the addition of the specifications in 12.2 to 12.5.

12.2 Manual scan path

During angle probe scanning (as illustrated in Figure 1), a slight swivelling movement up to an angle of approximately 10° on either side of the nominal beam direction shall be applied to the probe.

12.3 Testing for imperfections perpendicular to the testing surface

Subsurface planar imperfections perpendicular to the testing surface are difficult to detect with single angle probe techniques. For such imperfections specific testing techniques should be considered, particularly for welds in thicker materials. Use of these testing techniques shall be defined by specification.

12.4 Location of indications

The location of all indications shall be defined by reference to a coordinate system, e.g. as shown in Figure 2. A point on the testing surface shall be selected as the origin for these measurements.

Where testing is carried out from more than one surface, reference points shall be established on each surface. In this case, care shall be taken to establish a positional relationship between all reference points used, so that the absolute location of all indications can be established from any nominated reference point.

In the case of circumferential welds, this may require the establishment of the inner and outer reference points prior to assembly for welding.

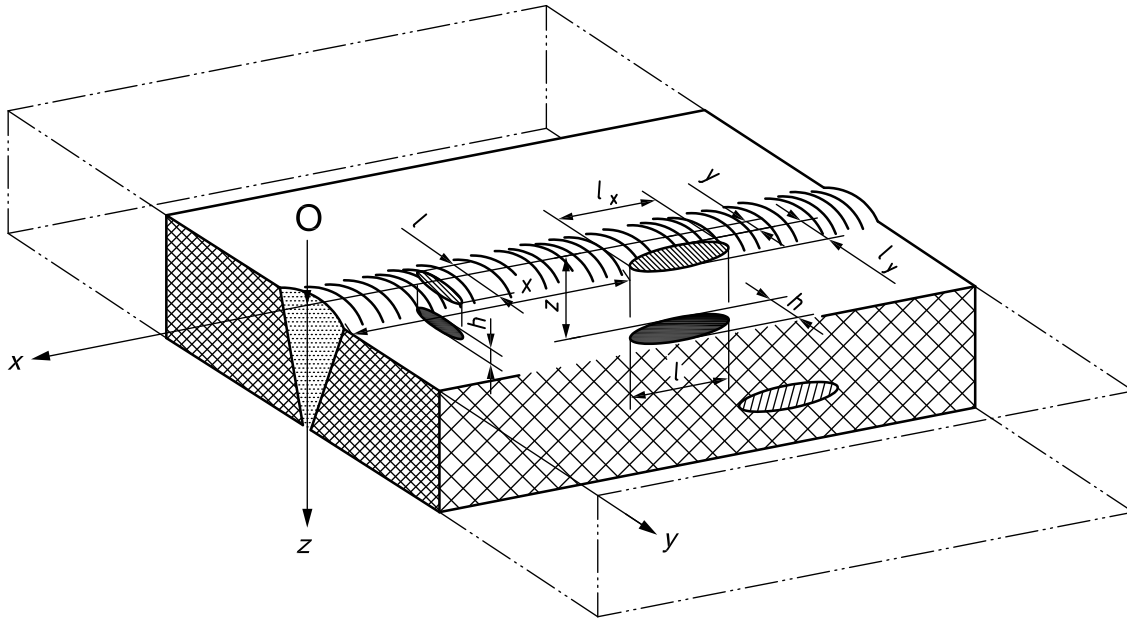

Key

O origin

NOTE For definitions of h , l , l_x , l_y , x , y , z , see Table 1.

Figure 2 — Coordinate system for defining the location on indications

12.5 Evaluation of indications

12.5.1 General

All relevant indications above the evaluation level shall be assessed in accordance with 12.5.2 to 12.5.4.

12.5.2 Maximum echo amplitude

The echo amplitude shall be maximized by probe movement and recorded in relation to the reference level.

12.5.3 Indication length

The length of the indication, in either the longitudinal or transverse direction (l_x , l_y), shall, where possible, be determined using the technique specified in the acceptance levels standard, unless otherwise agreed.

12.5.4 Indication height

Indication height measurement shall only be carried out if required by specification.

12.5.5 Characterization of indications

If specified, indications shall be characterized in accordance with ISO 23279.

13 Test report

The test report shall include at least the following information:

- a) identification of the object under test:
 - 1) material and product form,
 - 2) dimensions,
 - 3) location of weld/welded joint examined,
 - 4) sketch showing geometrical configuration (if necessary),
 - 5) reference to the welding procedure, specification and heat treatment,
 - 6) state of manufacture,
 - 7) surface conditions,
 - 8) temperature of the object;
- b) contract requirements, e.g. specifications, guidelines, special agreements, etc.;
- c) place and date of testing;
- d) identification of test organizations and identification and certification of operator;
- e) maker and type of ultrasonic instrument with identification number, if required;
- f) maker, type, nominal frequency, size of element and actual angle of incidence of probes used with identification number, if required;
- g) identification of reference blocks used with a sketch, if necessary;
- h) couplant medium;
- i) testing level(s) and reference to written procedure when used;
- j) extent of testing;
- k) location of the scanning areas;
- l) reference points and details of coordinate system used as specified in 12.4;
- m) identification of probe positions, as specified in Annex A or by use of a sketch;
- n) time base range;
- o) method and values used for sensitivity setting (gain setting for reference levels and values used for transfer corrections);
- p) reference levels;

ISO 17640:2010(E)

- q) result of the parent material test;
- r) standards for acceptance levels;
- s) deviations from this International Standard, or contract requirements;
- t) coordinates of the indication, as specified in 12.4, with details of associated probes and corresponding probe positions;
- u) maximum echo amplitude as specified in 12.5.2 and information, if required, on the type and size of indication;
- v) lengths of indications as specified in 12.5.3;
- w) results of evaluation according to specified acceptance levels;
- x) a reference to this International Standard (ISO 17640:2010).

Annex A
(normative)

Testing levels for various types of welded joints

See Figures A.1 to A.7 and Tables A.1 to A.7.

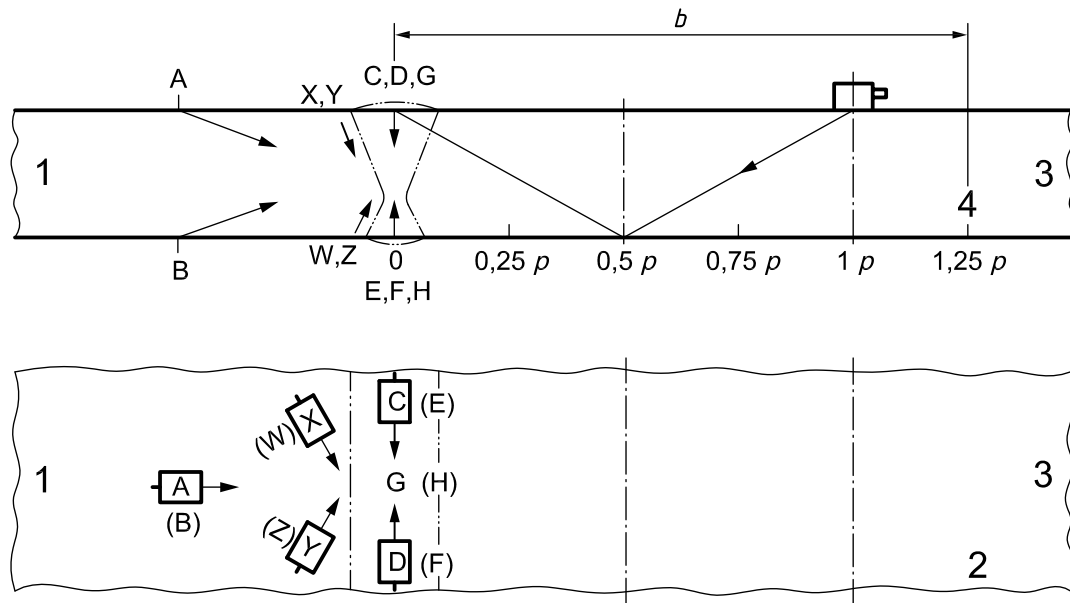

Key

- 1 position 1
- 2 position 2
- 3 position 3
- 4 position 4
- A, B, C, D, E, F, G, H, W, X, Y, Z probe positions
- b scanning zone width (SZW) related to skip distance, p
- p full skip distance

Figure A.1 — Butt joints in plates and pipes

Table A.1 — Butt joints in plates and pipes (for symbols, see key to Figure A.1)

Testing level	Thickness of the parent material mm	Longitudinal indications						Transverse indications				Notes
		Required number of			Total number of scans	Notes	Required number of		Total number of scans			
		Probe angles	Probe positions	Scanning zone width			Probe positions	T-scans				
										L-scans	N-scans	
A	$8 \leq t < 15$	1	A or B	1,25 <i>p</i>	—	2	a	1	(X and Y) or (W and Z)	4	c	
	$15 \leq t < 40$	1	A or B	1,25 <i>p</i>	—	2	a	1	(X and Y) or (W and Z)	4	c	
B	$8 \leq t < 15$	1	A or B	1,25 <i>p</i>	—	2	e	1	(X and Y) or (W and Z)	4	c	
	$15 \leq t < 40$	2 ^f	A or B	1,25 <i>p</i>	—	4	be	1	(X and Y) or (W and Z)	4	c	
	$40 \leq t < 60$	2	A or B	1,25 <i>p</i>	—	4	b	2	(X and Y) or (W and Z)	8	c	
	$60 \leq t \leq 100$	2	A or B	1,25 <i>p</i>	—	4	b	2	(C and D) or (E and F)	4	cd	
C	$8 \leq t < 15$	1	A or B	1,25 <i>p</i>	G or H	3	d	1	(C and D) or (E and F)	2	d	
	$15 \leq t \leq 40$	2	A or B	1,25 <i>p</i>	G or H	5	bd	2	(C and D) or (E and F)	4	d	
	> 40	2	A or B	1,25 <i>p</i>	G or H	5	bd	2	(C and D) or (E and F)	4	d	

a May be limited by agreement to one scan from one side.
b Additional testing by tandem technique by special agreement.
c Required only by special agreement.
d The surface of the weld cap shall comply with the requirement in Clause 8. This may require dressing of the weld cap. However, for single sided circumferential pipe welds, the outside cap only is to be dressed.
e If only accessible from one side, two angles shall be used.
f In the range $15 \text{ mm} < t \leq 25 \text{ mm}$, one angle is sufficient provided the frequency is below 3 MHz.

NOTE L-scan: scan for longitudinal indications using angle beam probes;
N-scan: scan using straight beam probe;
T-scan: scan for transverse indications using angle beam probes;
p is the full skip distance.

Table A.2 — Structural T-joints (for symbols, see key to Figure A.2)

Testing level	Thickness of the parent material mm	Longitudinal indications						Transverse indications				Notes
		Required number of						Required number of				
		L-scans		N-scans		Total number of scans		T-scans		Total number of scans		
		Probe angles	Probe positions	Scanning zone width	Probe positions	Scanning zone width	Probe angles	Probe positions	Scanning zone width			
A	$8 \leq t < 15$	1	A or B	1,25 p	C ^c	—	—	—	—	—	—	a
	$15 \leq t < 40$	1	A or B	1,25 p	C ^c	c	—	—	—	—	—	a
	$8 \leq t < 15$	1	A or B	1,25 p	C ^c	—	F and G	c	2	2	b	
B	$15 \leq t < 40$	1	A and B	1,25 p	C ^c	c	(F and G) or (X and Y) or (W and Z)	c f + g	2	2	b	
	$40 \leq t \leq 100$	2	A and B	0,75 p	C ^c	c	(F and G) or (X and Y) or (W and Z)	c f + g	2	2	b	
C	$8 \leq t < 15$	1	A and B	1,25 p	C ^c	c	F and G	c f + g	4	4	b	
	$15 \leq t < 40$	2	(A and B) and (D and E)	1,25 p	C ^c	c	(F and G) and (X and Y) or (W and Z)	c f + g	4	4	b	
		1	(A and B) and (D and E)	1,25 p d + e	C ^c	c	(F and G) and (X and Y) or (W and Z)	c f + g	8	8	b	
	$40 \leq t \leq 100$	2	(A and B) and (D and E)	0,75 p	C ^c	c	(F and G) and (X and Y) or (W and Z)	c f + g	8	8	b	
		1	(A and B) and (D and E)	0,75 p d + e	C ^c	c	(F and G) and (X and Y) or (W and Z)	c f + g	8	8	b	
	> 100	3	(A and B) and (D and E)	0,75 p	C ^c	c	(F and G) and (X and Y) or (W and Z)	c f + g	8	8	b	
		1	(A and B) and (D and E)	0,75 p d + e	C ^c	c	(F and G) and (X and Y) or (W and Z)	c f + g	8	8	b	
<p>a Not applicable.</p> <p>b Shall be carried out by special agreement only.</p> <p>c To be substituted by tandem technique from A or B if C is not possible.</p>												
<p>NOTE L-scan: scan for longitudinal indications using angle beam probes; N-scan: scan using straight beam probe; T-scan: scan for transverse indications using angle beam probes; p is the full skip distance.</p>												

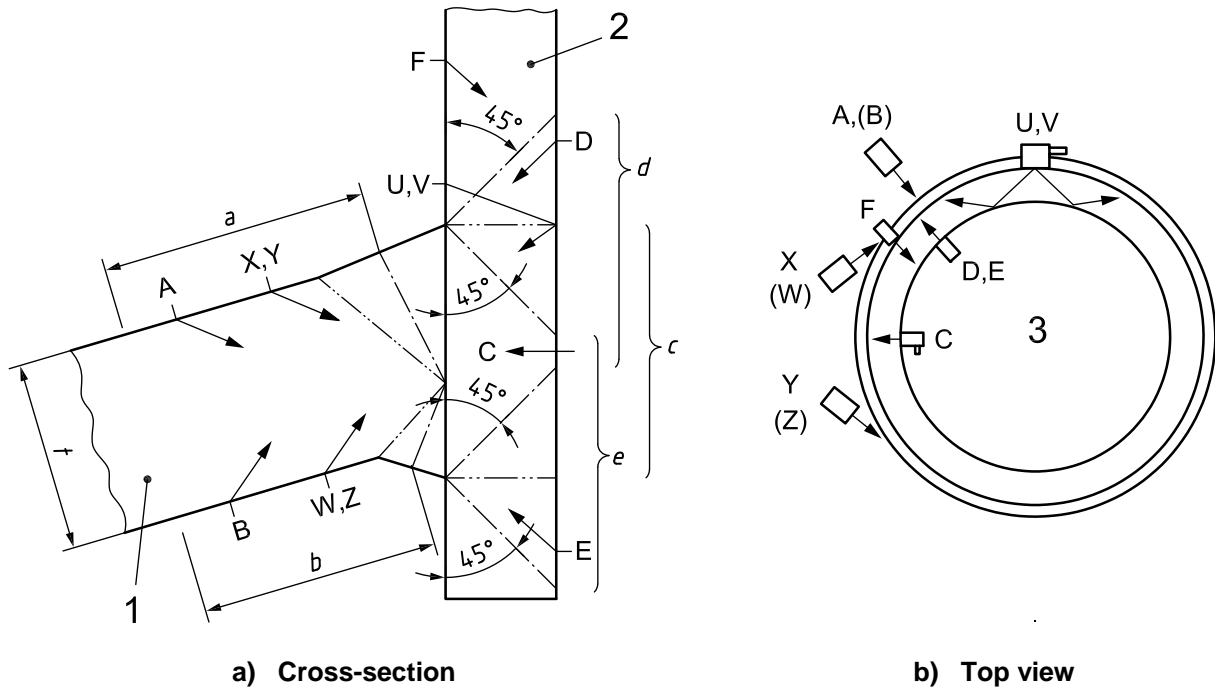

Key

- | | |
|------------------------------------|---|
| 1 | component 1, cylindrical shell/flat plate |
| 2 | component 2, nozzle |
| 3 | normal probe |
| A, B, C, D, E, F, U, V, W, X, Y, Z | probe positions |
| <i>a, b, c, d, e</i> | scanning zone width indicators |
| <i>t</i> | thickness |

Figure A.3 — Set-through nozzle joints

Table A.3 — Set-through nozzle joints (for symbols, see key to Figure A.3)

Testing level	Thickness of the parent material mm	Longitudinal indications						Transverse indications				Notes
		Required number of						Required number of		Total number of scans		
		Probe angles	Probe positions	Scanning zone width	Probe positions	Scanning zone width	Total number of scans	Probe angles	Probe positions			
										L-scans		
A	$8 \leq t < 15$	1	A	$1,25 p$	C	c	1	—	—	—	a	
	$15 \leq t \leq 40$	1	A or F or D	$1,25 p$ <i>d</i>	C	c	2	—	—	—	a	
	$8 \leq t < 15$	1	A or D	$1,25 p$ <i>d + e</i>	C	c	2	1	(U and V) or (X and Y) or (W and Z)	2	b	
B	$15 \leq t < 40$	1	A or (D and E)	$1,25 p$ <i>d + e</i>	C	c	2 or 3	1	(U and V) or (X and Y) or (W and Z)	2	b	
	$40 \leq t < 60$	1	(A or B) and (D and E)	$1,25 p$ <i>d + e</i>	C	c	4	1	(X and Y) and (W and Z)	4	b	
	$60 \leq t \leq 100$	2 1	(A and B) and (D and E)	$0,5 p$ <i>d + e</i>	C	c	7	2	(X and Y) and (W and Z)	8	b	
C	$8 \leq t < 15$	1	(A or B) and (D or E)	$1,25 p$ <i>d or e</i>	C	c	3	1	(U and V) or (X and Y) and (W and Z)	2 or 4	b	
	$15 \leq t \leq 40$	2	(A or B) and (D or E)	$0,5 p$ <i>d or e</i>	C	c	5	2	(X and Y) and (W and Z)	8	b	
	> 40	2	(A or B) and (D or E)	$0,5 p$ <i>d + e</i>	C	c	9	2	(X and Y) and (W and Z)	8	b	

a Not applicable.
b Shall be carried out by special agreement only.

NOTE L-scan: scan for longitudinal indications using angle beam probes;
N-scan: scan using straight beam probe;
T-scan: scan for transverse indications using angle beam probes;
p is the full skip distance.

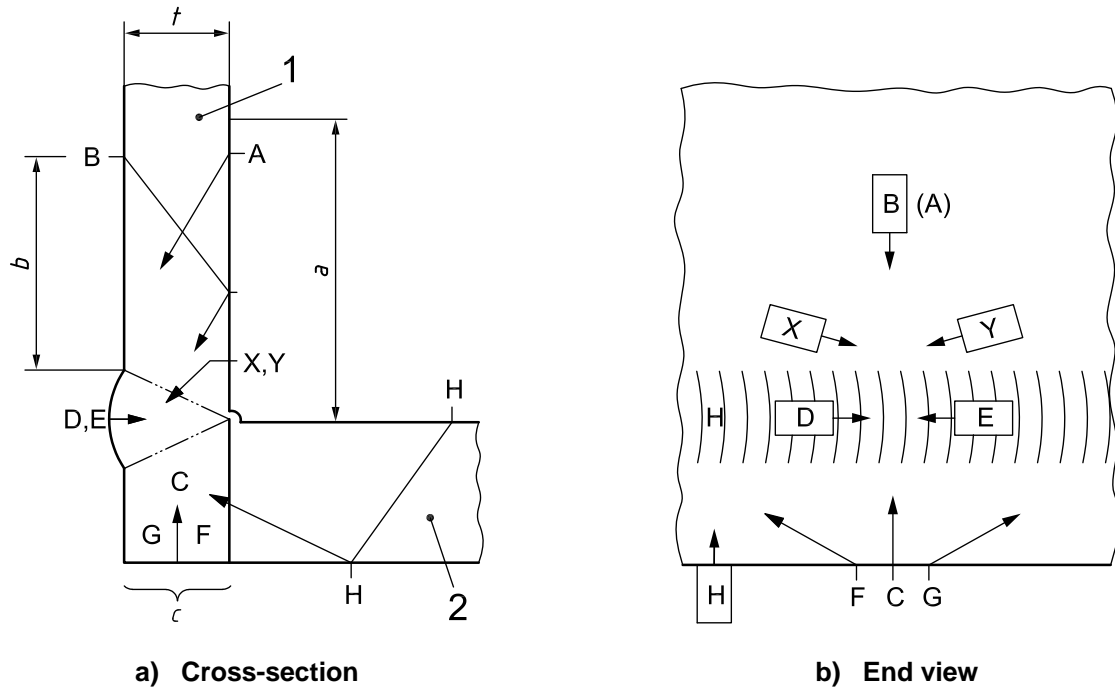

Key

- 1 component 1, nozzle
- 2 component 2, shell
- A, B, C, D, E, F, G, H, X, Y probe positions
- a, b, c* scanning zone width indicators
- t* thickness

Figure A.4 — Structural L-joints

Table A.4 — Structural L-joints (for symbols, see key to Figure A.4)

Testing level	Thickness of the parent material mm	Longitudinal indications						Transverse indications				Notes
		Required number of			Scanning zone width	Probe positions	Total number of scans	Required number of	Probe positions	Total number of scans		
		Probe angles	Probe positions	Scanning zone width							Probe angles	
L-scans			N-scans			T-scans						
A	$8 \leq t < 15$	1	A or B or H	1,25 <i>p</i>	C	<i>c</i>	1	—	—	—	a	
	$15 \leq t \leq 40$	1	A or B or H	1,25 <i>p</i>	C	<i>c</i>	2	—	—	—	a	
B	$8 \leq t < 15$	1	A or B or H	1,25 <i>p</i>	C	<i>c</i>	1	(F and G) or (X and Y)	2	b		
	$15 \leq t < 40$	2	A or B or H	1,25 <i>p</i>	C	<i>c</i>	3	(F and G) or (X and Y)	4	b		
	$40 \leq t \leq 100$	2	(H or A) and B	0,75 <i>p</i>	C	<i>c</i>	5	D and E	4	bc		
C	$8 \leq t < 15$	1	(H or A) and B	1,25 <i>p</i>	C	<i>c</i>	3	D and E	2	bc		
	$15 \leq t < 40$	2	(H or A) and B	1,25 <i>p</i>	C	<i>c</i>	5	D and E	2	bc		
	$40 \leq t \leq 100$	3	(H or A) and B	1,25 <i>p</i>	C	<i>c</i>	7	D and E	4	bc		
		> 100	3	(H or A) and B	0,5 <i>p</i>	C	<i>c</i>	7	D and E	4	bc	

a Not applicable.
b Shall be carried out by special agreement only.
c The surface of the weld cap shall comply with the requirement in Clause 8. This may require dressing of the weld cap.

NOTE L-scan: scan for longitudinal indications using angle beam probes;
N-scan: scan using straight beam probe;
T-scan: scan for transverse indications using angle beam probes;
p is the full skip distance.

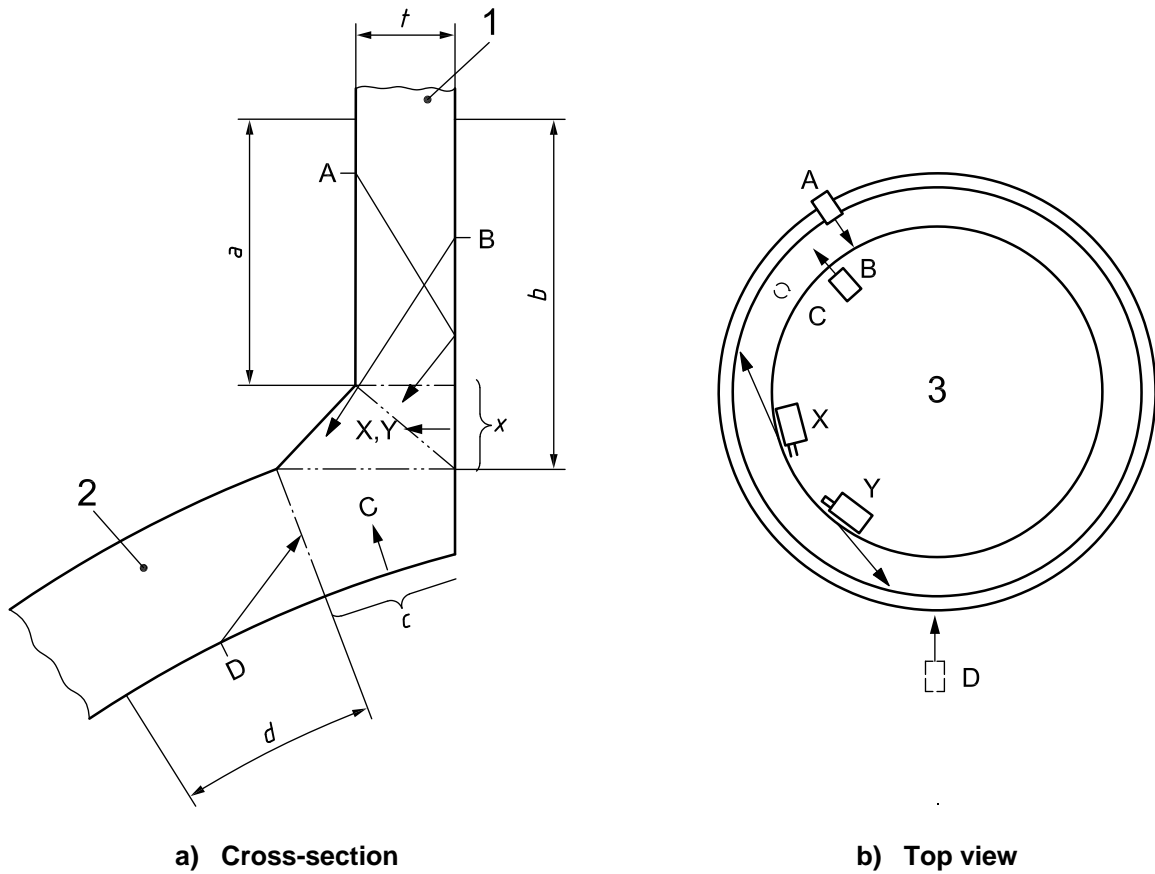

Key

- 1 component 1, nozzle
- 2 component 2, shell
- 3 normal probe
- A, B, C, D, X, Y probe positions
- a, b, c, d, x scanning zone width indicators
- t thickness

Figure A.5 — Set-on nozzle joints

Table A.5 — Set-on nozzle joints (for symbols, see key to Figure A.5)

Testing level	Thickness of the parent material mm	Longitudinal indications						Transverse indications				Notes		
		Required number of						Required number of			Total number of scans			
		Probe angles	Probe positions	Scanning zone width	Probe positions	Scanning zone width	Total number of scans	Probe angles	Probe positions	T-scans				
													L-scans	
A	$8 \leq t < 15$	1	A or B	$1,25 p$ $0,50 p$	—	—	—	—	—	—	—	a		
	$15 \leq t \leq 40$	1	A or B	$1,25 p$ $0,50 p$	C	c	2	—	—	—	—	a		
B	$8 \leq t < 15$	2	A or B	$1,25 p$ $0,50 p$	—	—	2	—	—	—	1	X and Y	2	bc
	$15 \leq t < 40$	2	A or B	$1,25 p$ $0,50 p$	C	c	3	—	—	—	1	X and Y	2	bc
	$40 \leq t < 60$	2	A and (B or D)	$1,25 p$ $0,50 p$	C	c	5	—	—	—	2	X and Y	4	bc
	$60 \leq t \leq 100$	2	A and (B or D)	$1,25 p$ $0,5 p$	C	c	5	—	—	—	2	X and Y	4	bc
C	$8 \leq t < 15$	3	A or B	$1,25 p$ $0,5 p$	C	c	4	—	—	—	1	X and Y	2	bc
	$15 \leq t < 40$	3	A or B	$1,25 p$ $0,5 p$	C	c	4	—	—	—	1	X and Y	2	bc
	$40 \leq t < 60$	3	A and B	$1,25 p$ $0,5 p$	C	c	7	—	—	—	2	X and Y	4	bc
	$60 \leq t \leq 100$	3	A and B	$1,25 p$ $0,5 p$	C	c	7	—	—	—	2	X and Y	4	bc

a Not applicable.
b Shall be carried out by special agreement only.
c The surface of the weld cap shall comply with the requirement in Clause 8. This may require dressing of the weld cap.

NOTE
L-scan: scan for longitudinal indications using angle beam probes;
N-scan: scan using straight beam probe;
T-scan: scan for transverse indications using angle beam probes;
p is the full skip distance.

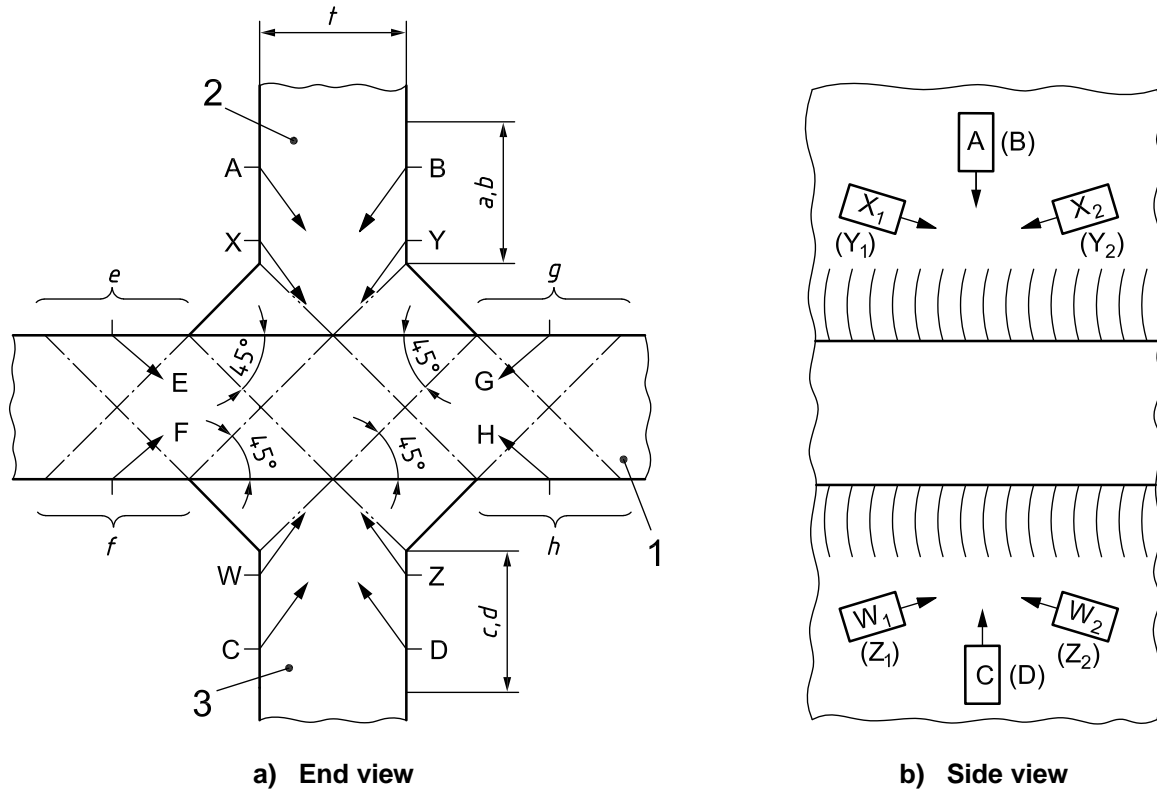

Key

- 1
- 2
- 3
- A, B, C, D, E, F, G, H, W, W₁, W₂, X, X₁, X₂, Y, Y₁, Y₂, Z, Z₁, Z₂
- a, b, c, d, e, f, g, h
- t

- component 1
- component 2
- component 3
- probe positions
- scanning zone width indicators
- thickness

Figure A.6 — Cruciform joints

Table A.6 — Cruciform joints (for symbols, see key to Figure A.6)

Testing level	Thickness of the parent material mm	Longitudinal indications					Transverse indications				Notes
		Required number of		Scanning zone width	Total number of scans	Notes	Required number of		Total number of scans		
		Probe angles	Probe positions				Probe angles	Probe positions			
				L-scans		T-scans					
A	$8 \leq t < 15$	1	(A and C) or (B and D)	1,25 <i>p</i>	2	—	—	—	—	a	
	$15 \leq t < 40$	1	A and B and C and D	0,75 <i>p</i>	4	c	—	—	—	a	
	$40 \leq t \leq 100$	2	A and B and C and D	0,75 <i>p</i>	8	c	—	—	—	—	
B	$8 \leq t < 15$	1	A and B and C and D	1,25 <i>p</i>	4	—	(X ₁ and Y ₁ and W ₁ and Z ₁) and (X ₂ and Y ₂ and W ₂ and Z ₂)	8	8	b	
	$15 \leq t < 40$	2	A and B and C and D	0,75 <i>p</i>	8	c	(X ₁ and Y ₁ and W ₁ and Z ₁) and (X ₂ and Y ₂ and W ₂ and Z ₂)	8	8	b	
	$40 \leq t \leq 100$	2 1	(A and B and C and D) and (E and F and G and H)	0,75 <i>p</i> <i>e - h</i>	12	d d	(X ₁ and Y ₁ and W ₁ and Z ₁) and (X ₂ and Y ₂ and W ₂ and Z ₂)	16	16	b	
C	$40 \leq t \leq 100$	2 1	(A and B) and (C and D) and (E and F) and (G and H) and tandem (A or B) and (C or D)	0,75 <i>p</i> <i>e - h</i>	14	—	(X ₁ and Y ₁ and W ₁ and Z ₁) and (X ₂ and Y ₂ and W ₂ and Z ₂)	16	16	b	

a Not applicable.
b Shall be carried out by special agreement only.
c If a more sensitive level is required, a tandem technique shall be applied.
d If a more sensitive level is required, a tandem technique shall be applied. In this case, E and F and G and H shall be omitted.

NOTE L-scan: scan for longitudinal indications using angle beam probes;
N-scan: scan using straight beam probe;
T-scan: scan for transverse indications using angle beam probes;
p is the full skip distance.

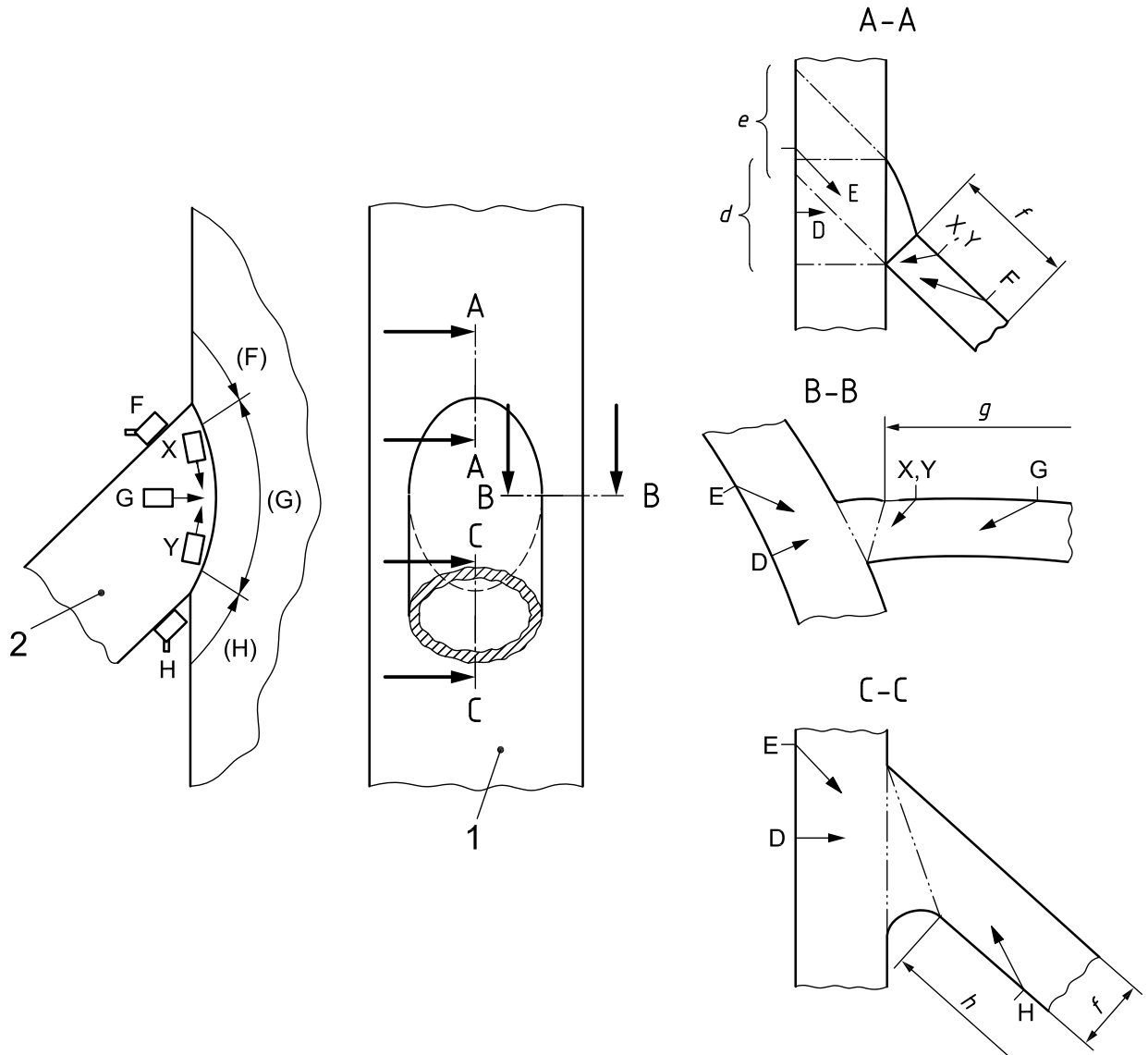

Key

- | | |
|------------------------------|--------------------------------|
| 1 | component 1, main pipe |
| 2 | component 2, branch pipe |
| A, B, C, D, E, F, G, H, X, Y | probe positions |
| <i>d, e, f, g, h</i> | scanning zone width indicators |

Figure A.7 — Node joints in tubular structures

Table A.7 — Node joints in tubular structures (for symbols, see key to Figure A.7)

Testing level	Thickness of the parent material mm	Longitudinal indications						Transverse indications				Notes
		Required number of						Required number of		Total number of scans		
		Probe angles	Probe positions	Scanning zone width	Probe positions	Scanning zone width	Total number of scans	Probe angles	Probe positions			
										L-scans		
A	$8 \leq t < 15$	2	F and G and H	1,25 <i>p</i>	—	—	6	—	—	—	ab	
	$15 \leq t < 40$	3	F and G and H	1,25 <i>p</i>	—	—	9	—	—	—	ab	
	$40 \leq t \leq 100$	3	F and G and H	1,25 <i>p</i>	—	—	9	—	—	—	ab	
B	$8 \leq t < 15$	2	F and G and H	1,25 <i>p</i> 0,50 <i>p</i>	D	<i>d</i>	7	1	X and Y	2	ac	
	$15 \leq t < 40$	3	F and G and H	1,25 <i>p</i> 0,50 <i>p</i>	D	<i>d</i>	10	2	X and Y	4	ac	
	$40 \leq t \leq 100$	3 1	(F and G and H) and E	1,25 <i>p</i> <i>e</i>	D	<i>d</i>	11	2	X and Y	4	ac	
C												

a Node joint testing shall usually be level D, requiring special agreement.
b Not applicable.
c If the bore of component 1 is not accessible (probe positions D and E), testing level B cannot be achieved.

NOTE L-scan: scan for longitudinal indications using angle beam probes;
N-scan: scan using straight beam probe;
T-scan: scan for transverse indications using angle beam probes;
p is the full skip distance.

