

INTERNATIONAL
STANDARD

ISO
17638

Second edition
2016-10-15

**Non-destructive testing of welds —
Magnetic particle testing**

Contrôle non destructif des assemblages soudés — Magnétoscopie



Reference number
ISO 17638:2016(E)

© ISO 2016



COPYRIGHT PROTECTED DOCUMENT

© ISO 2016, Published in Switzerland

All rights reserved. Unless otherwise specified, no part of this publication may be reproduced or utilized otherwise in any form or by any means, electronic or mechanical, including photocopying, or posting on the internet or an intranet, without prior written permission. Permission can be requested from either ISO at the address below or ISO's member body in the country of the requester.

ISO copyright office
Ch. de Blandonnet 8 • CP 401
CH-1214 Vernier, Geneva, Switzerland
Tel. +41 22 749 01 11
Fax +41 22 749 09 47
copyright@iso.org
www.iso.org

Contents

Page

Foreword	iv
1 Scope	1
2 Normative references	1
3 Terms and definitions	1
4 Safety precautions	1
5 General	1
5.1 Information required prior to testing.....	1
5.2 Additional pre-test information.....	2
5.3 Personnel qualification.....	2
5.4 Surface conditions and preparation.....	2
5.5 Magnetizing.....	2
5.5.1 Magnetizing equipment.....	2
5.5.2 Verification of magnetization.....	3
5.6 Application techniques.....	3
5.6.1 Field directions and testing area.....	3
5.6.2 Typical magnetic testing techniques.....	6
5.7 Detection media.....	9
5.7.1 General.....	9
5.7.2 Verification of detection media performance.....	9
5.8 Viewing conditions.....	10
5.9 Application of detection media.....	10
5.10 Overall performance test.....	10
5.11 False indications.....	10
5.12 Recording of indications.....	10
5.13 Demagnetization.....	11
5.14 Test report.....	11
Annex A (informative) Variables affecting the sensitivity of magnetic particle testing	13
Bibliography	15

Foreword

ISO (the International Organization for Standardization) is a worldwide federation of national standards bodies (ISO member bodies). The work of preparing International Standards is normally carried out through ISO technical committees. Each member body interested in a subject for which a technical committee has been established has the right to be represented on that committee. International organizations, governmental and non-governmental, in liaison with ISO, also take part in the work. ISO collaborates closely with the International Electrotechnical Commission (IEC) on all matters of electrotechnical standardization.

The procedures used to develop this document and those intended for its further maintenance are described in the ISO/IEC Directives, Part 1. In particular the different approval criteria needed for the different types of ISO documents should be noted. This document was drafted in accordance with the editorial rules of the ISO/IEC Directives, Part 2 (see www.iso.org/directives).

Attention is drawn to the possibility that some of the elements of this document may be the subject of patent rights. ISO shall not be held responsible for identifying any or all such patent rights. Details of any patent rights identified during the development of the document will be in the Introduction and/or on the ISO list of patent declarations received (see www.iso.org/patents).

Any trade name used in this document is information given for the convenience of users and does not constitute an endorsement.

For an explanation on the meaning of ISO specific terms and expressions related to conformity assessment, as well as information about ISO's adherence to the World Trade Organization (WTO) principles in the Technical Barriers to Trade (TBT) see the following URL: www.iso.org/iso/foreword.html.

The committee responsible for this document is ISO/TC 44, *Welding and allied processes*, Subcommittee SC 5, *Testing and inspection of welds*.

This second edition cancels and replaces the first edition (ISO 17638:2003), which has been technically revised.

Requests for official interpretations of any aspect of this document should be directed to the Secretariat of ISO/TC 44/SC 5 via your national standards body. A complete listing of these bodies can be found at www.iso.org.

Non-destructive testing of welds — Magnetic particle testing

1 Scope

This document specifies techniques for detection of surface imperfections in welds in ferromagnetic materials, including the heat affected zones, by means of magnetic particle testing. The techniques are suitable for most welding processes and joint configurations. Variations in the basic techniques that will provide a higher or lower test sensitivity are described in [Annex A](#).

This document does not specify acceptance levels of the indications. Further information on acceptance levels for indications may be found in ISO 23278 or in product or application standards.

2 Normative references

The following documents are referred to in the text in such a way that some or all of their content constitutes requirements of this document. For dated references, only the edition cited applies. For undated references, the latest edition of the referenced document (including any amendments) applies.

ISO 3059, *Non-destructive testing — Penetrant testing and magnetic particle testing — Viewing conditions*

ISO 9934-1:2015, *Non-destructive testing — Magnetic particle testing — Part 1: General principles*

ISO 9934-2, *Non-destructive testing — Magnetic particle testing — Part 2: Detection media*

ISO 9934-3, *Non-destructive testing — Magnetic particle testing — Part 3: Equipment*

3 Terms and definitions

For the purposes of this document, the terms and definitions given in ISO 12707 and ISO 17635 apply.

ISO and IEC maintain terminological databases for use in standardization at the following addresses:

- IEC Electropedia: available at <http://www.electropedia.org/>
- ISO Online browsing platform: available at <http://www.iso.org/obp>

4 Safety precautions

Special consideration shall be given to toxic, inflammable and/or volatile materials, electrical safety and unfiltered UV radiation.

Magnetic particle testing often creates high magnetic fields close to the object under test and the magnetising equipment. Items sensitive to these fields should be excluded from such areas.

5 General

5.1 Information required prior to testing

Prior to testing, the following items shall be specified (where applicable):

- a) specific test procedure;
- b) certification requirements for NDT personnel;

ISO 17638:2016(E)

- c) extent of coverage;
- d) state of manufacture;
- e) testing techniques to be used;
- f) overall performance test;
- g) any demagnetization;
- h) acceptance level;
- i) action necessary for unacceptable indications.

5.2 Additional pre-test information

Prior to testing, the following additional information can also be required:

- a) type and designation of the parent and weld materials;
- b) welding process;
- c) location and extent of welds to be tested;
- d) joint preparation and dimensions;
- e) location and extent of any repairs;
- f) post-weld treatment (if any);
- g) surface conditions.

Operators may ask for further information that could be helpful in determining the nature of any indications detected.

5.3 Personnel qualification

Magnetic particle testing of welds and the evaluation of results for final acceptance shall be performed by qualified and capable personnel. It is recommended that personnel be qualified in accordance with ISO 9712 or an equivalent standard at an appropriate level in the relevant industry sector.

5.4 Surface conditions and preparation

Areas to be tested shall be dry unless appropriate products for wet surfaces are used. It may be necessary to improve the surface condition, e.g. by use of abrasive paper or local grinding to permit accurate interpretation of indications.

Any cleaning or surface preparation shall not be detrimental to the material, the surface finish or the magnetic testing media. Detection media shall be used within the temperature range limitations set by the manufacturer.

5.5 Magnetizing

5.5.1 Magnetizing equipment

General magnetization requirements shall be in accordance with ISO 9934-1:2015, Clause 8.

Unless otherwise specified, for example, in an application standard, the following types of alternating current-magnetizing equipment shall be used:

- a) electromagnetic yokes;

- b) current flow equipment with prods;
- c) adjacent or threading conductors or coil techniques.

DC electromagnets and permanent magnets may only be used by agreement at the time of enquiry and order.

The magnetizing equipment shall conform to ISO 9934-3.

Where prods are used, precautions shall be taken to minimize overheating, burning or arcing at the contact tips. Removal of arc burns shall be carried out where necessary. The affected area shall be tested by a suitable method to ensure the integrity of the surface.

5.5.2 Verification of magnetization

For the verification of magnetization, see ISO 9934-1:2015, 8.2.

For structural steels in welds, a tangential field between 2 kA/m to 6 kA/m (r.m.s.) is recommended.

The adequacy of the surface flux density shall be established by one or more of the following methods:

- a) by testing a representative component containing fine natural or artificial discontinuities in the least favourable locations;
- b) measurement of the tangential field strength as close as possible to the surface using a Hall effect probe; the appropriate tangential field strength can be difficult to measure close to abrupt changes in the shape of a component or where flux leaves the surface of a component;
- c) calculation of the approximate current value in order to achieve the recommended tangential field strength; the calculation can be based on the current values specified in [Figure 5](#) and [Figure 6](#);
- d) by the use of other methods based on established principles.

Flux indicators (i.e. shim-type) placed in contact with the surface under test provide a guide to the magnitude and direction of the tangential field strength, but should not be used to verify that the tangential field strength is acceptable.

NOTE Information on b) is given in ISO 9934-3.

5.6 Application techniques

5.6.1 Field directions and testing area

The detectability of an imperfection depends on the angle of its major axis with respect to the direction of the magnetic field. This is explained for one direction of magnetization in [Figure 1](#).

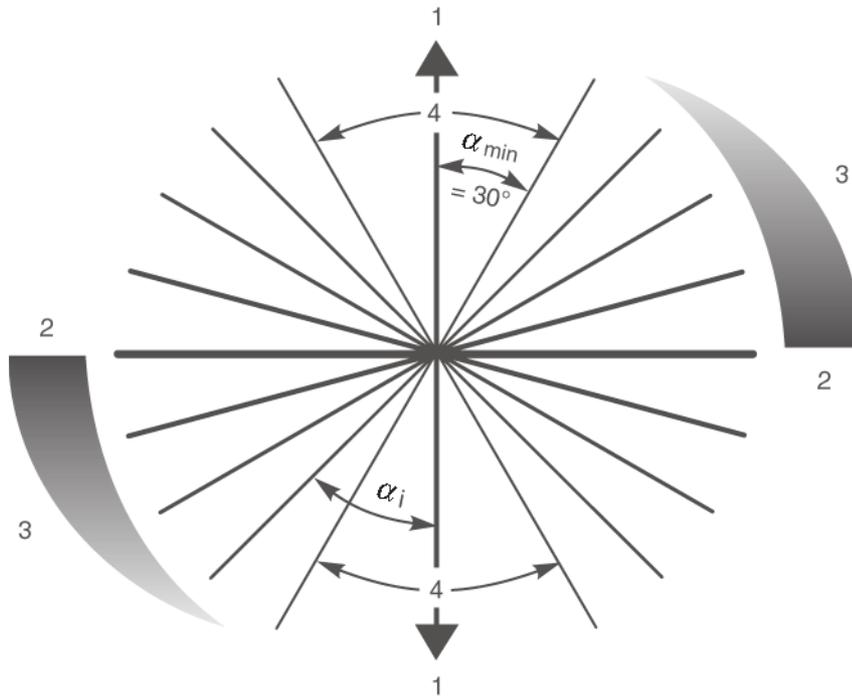

Key

- | | | | |
|---|--------------------------|----------------|--|
| 1 | magnetic field direction | α | angle between the magnetic field and the direction of the imperfection |
| 2 | optimum sensitivity | α_{min} | minimum angle for imperfection detection |
| 3 | reducing sensitivity | α_i | example of imperfection orientation |
| 4 | insufficient sensitivity | | |

Figure 1 — Directions of detectable imperfections

To ensure detection of imperfections in all orientations, the welds shall be magnetized in two directions approximately perpendicular to each other with a maximum deviation of 30°. This can be achieved using one or more magnetization methods.

Testing in only one field direction is not recommended but may be carried out if specified, for example, in an application standard.

When using yokes or prods, there will be an area of the component in the vicinity of each pole piece or tip that will be impossible to test due to excessive magnetic field strength. This is usually seen as furring of particles.

Care shall be taken to ensure adequate overlap of the testing areas as shown in [Figure 2](#) and [Figure 3](#).

Dimensions in millimetres

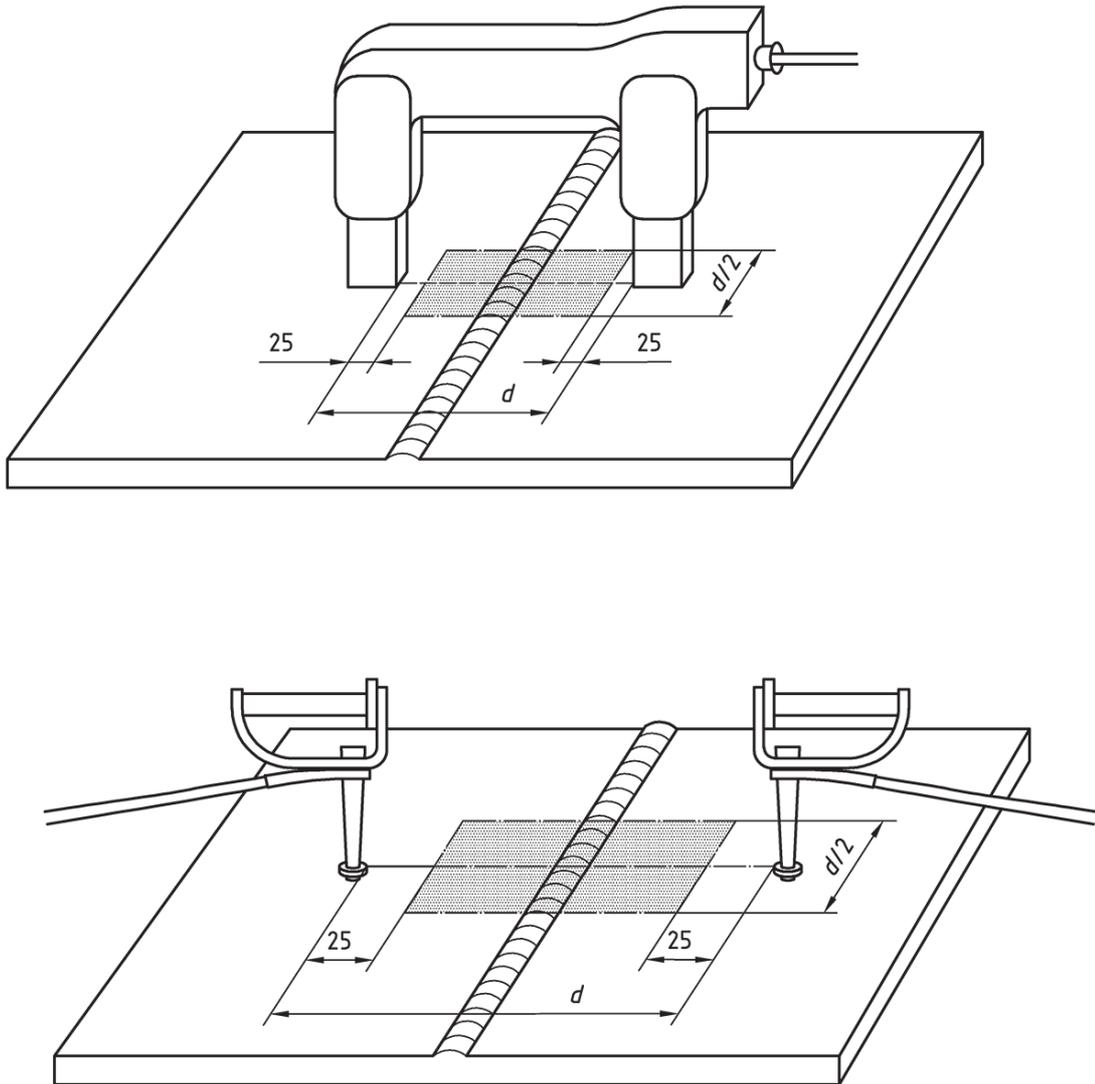

Key

d separation between the poles (yoke/prod)

Figure 2 — Examples of effective testing area (shaded) for magnetizing with yokes and prods

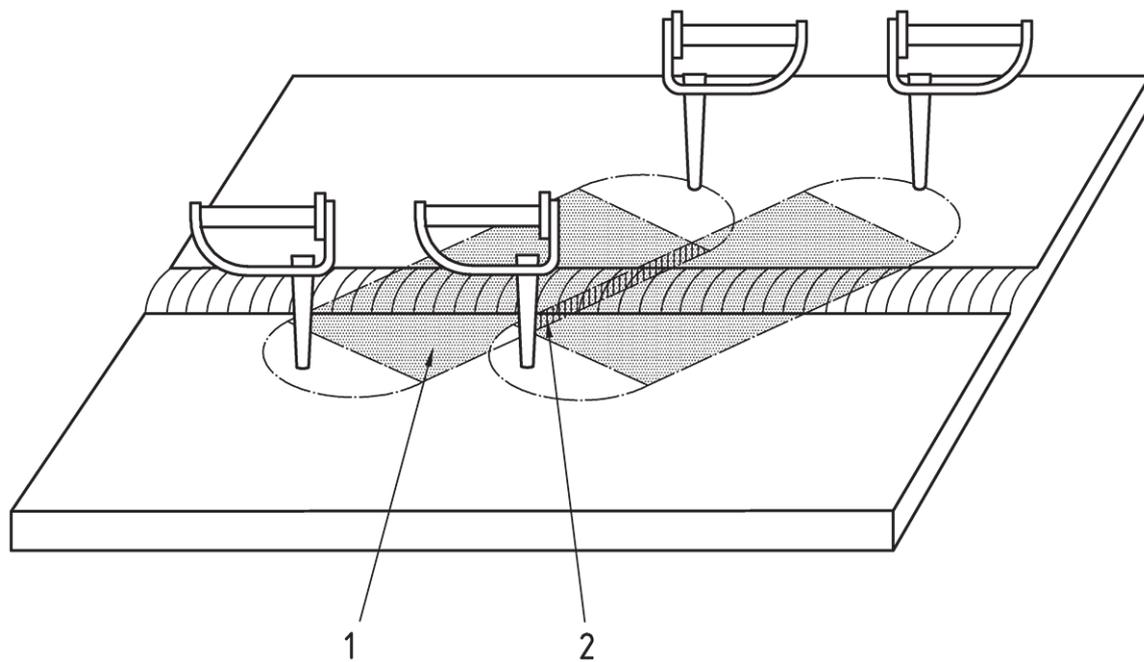

Key

- 1 effective area
- 2 overlap

Figure 3 — Overlap of effective areas

5.6.2 Typical magnetic testing techniques

Magnetic particle testing techniques for common weld joint configurations are shown in [Figure 4](#), [Figure 5](#) and [Figure 6](#). Values are given for guidance purposes only. Where possible, the same directions of magnetization and field overlaps should be used for other weld geometries to be tested. The width of the flux current (in case of flux current technique) or of the magnetic flow (in case of magnetic flow technique) path in the material, d , shall be greater than or equal to the width of the weld and the heat affected zone +50 mm and in all cases, the weld and the heat affected zone shall be included in the effective area. The direction of magnetization with respect to the orientation of the weld shall be specified.

Dimensions in millimetres

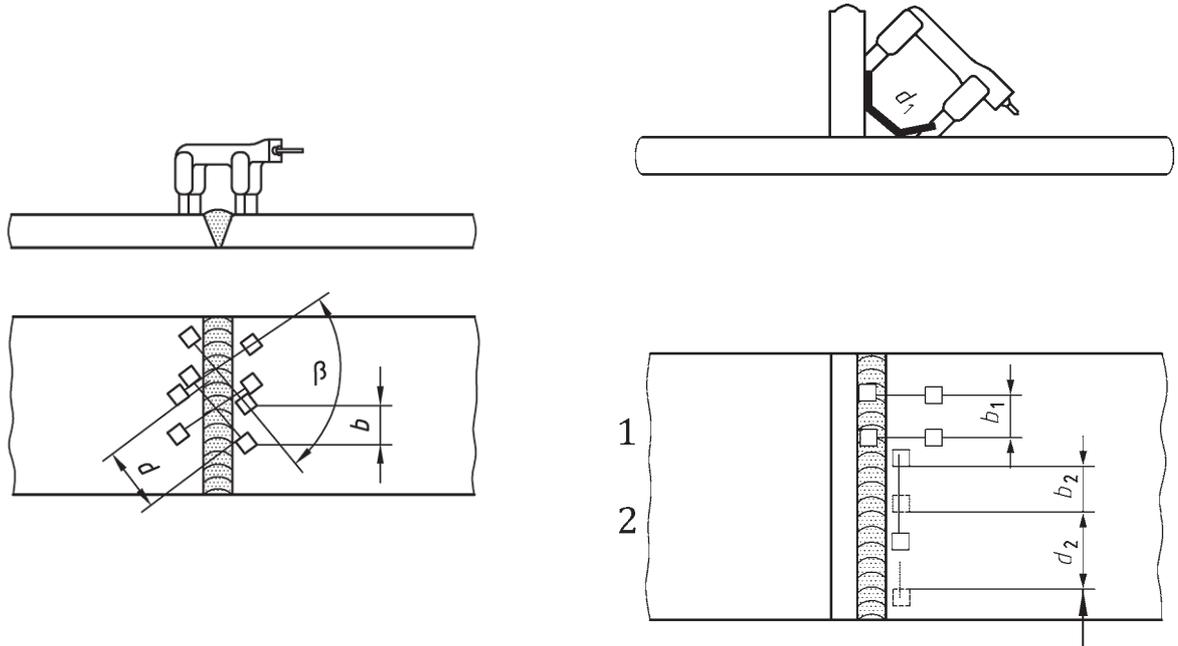

$$d \geq 75$$

$$b \leq d/2$$

$$\beta \approx 90^\circ$$

$$d_1 \geq 75$$

$$b_1 \leq d_1/2$$

$$b_2 \leq d_2 - 50$$

$$d_2 \geq 75$$

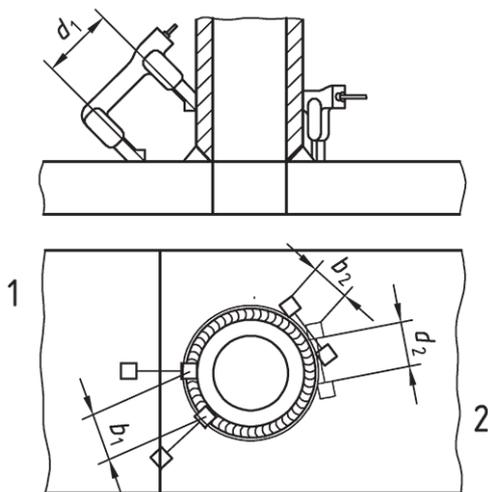

$$d_1 \geq 75$$

$$d_2 \geq 75$$

$$b_1 \leq d_1/2$$

$$b_2 \leq d_2 - 50$$

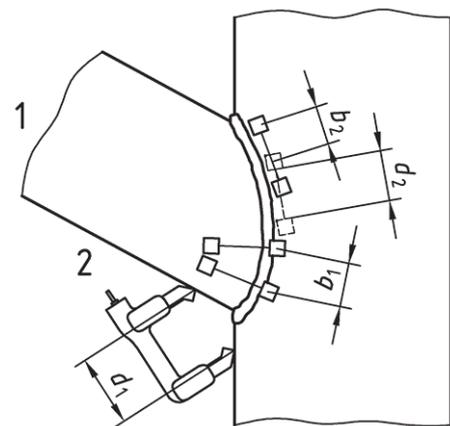

$$d_1 \geq 75$$

$$d_2 > 75$$

$$b_1 \leq d_1/2$$

$$b_2 \leq d_2 - 50$$

Key

- 1 longitudinal cracks
- 2 transverse cracks

Figure 4 — Typical magnetizing techniques for yokes

Dimensions in millimetres

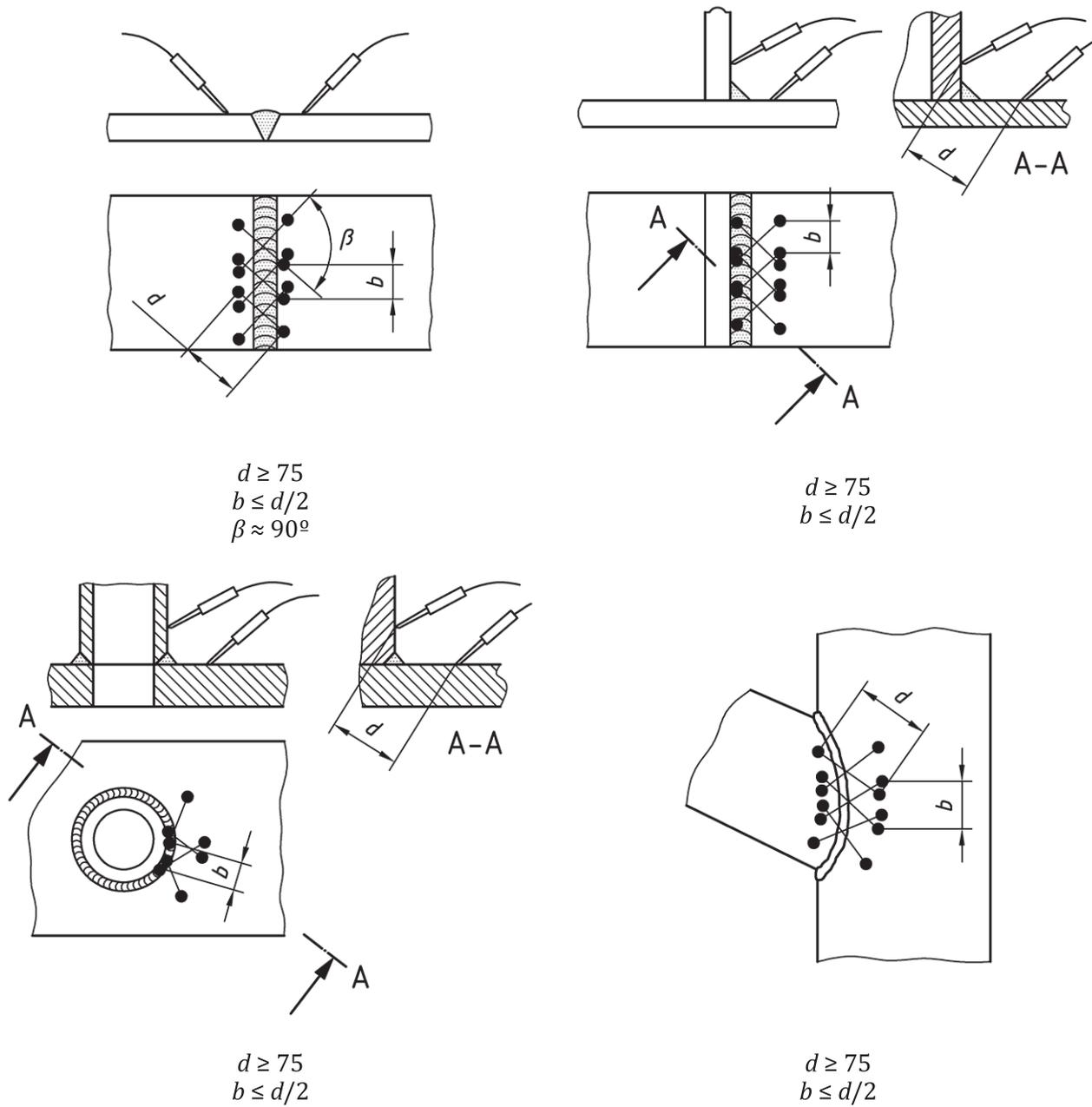
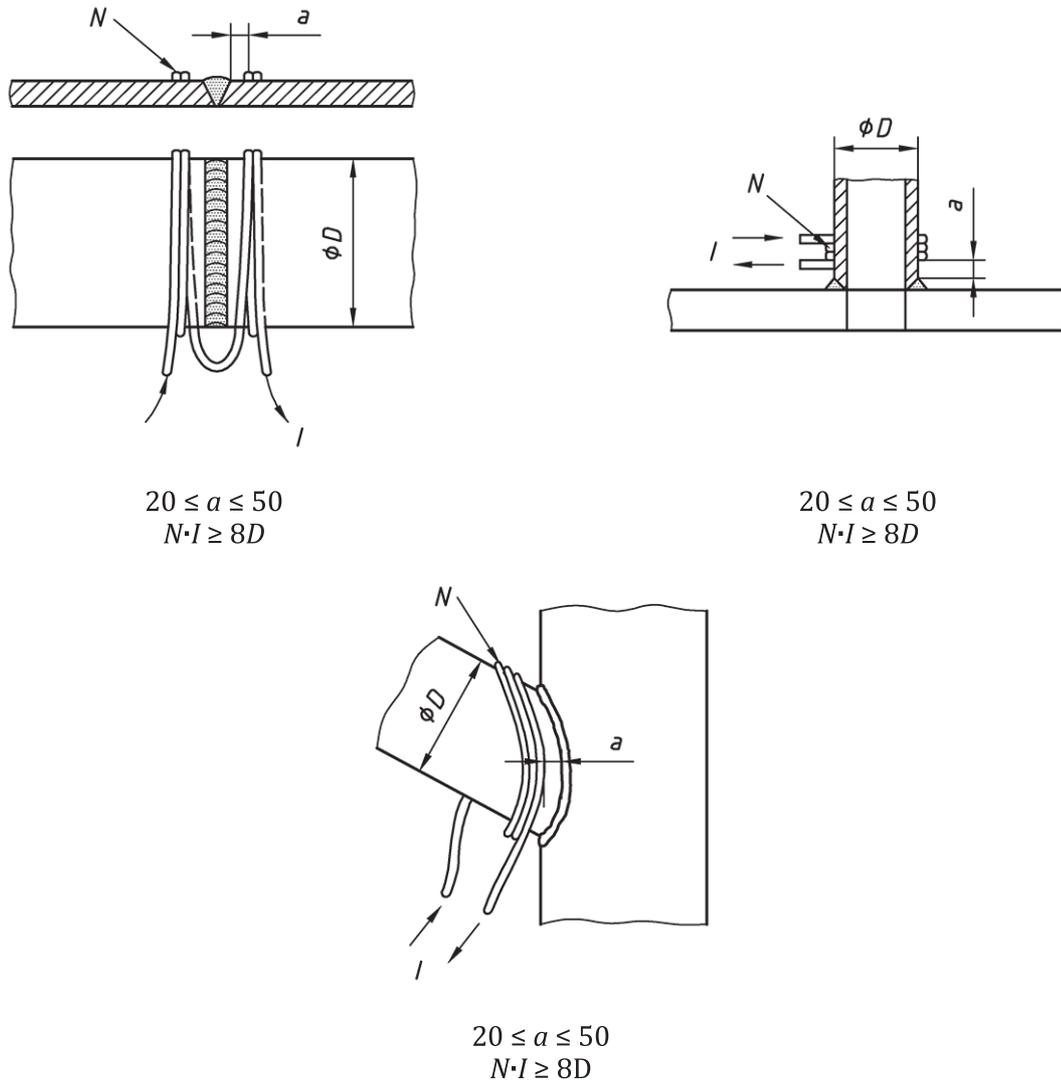

Figure 5 — Typical magnetizing techniques for prods, using a magnetizing current prod spacing

Dimensions in millimetres



Key

N number of turns

I current (r.m.s)

a distance between weld and coil or cable

Figure 6 — Typical magnetizing techniques for flexible cables or coils (for longitudinal cracks)

5.7 Detection media

5.7.1 General

Detection media may be either in dry powder form or magnetic inks in accordance with ISO 9934-2.

5.7.2 Verification of detection media performance

The detection media used shall fulfil the requirements of ISO 9934-2.

Indications obtained with the medium to be verified shall be compared against those obtained from a medium having a known and acceptable performance. For this purpose, the reference indications may be

- real imperfections,
- photograph(s), and
- replica(s).

5.8 Viewing conditions

The viewing conditions shall be in accordance with ISO 3059.

5.9 Application of detection media

After the object has been prepared for testing, the detection medium shall be applied by spraying, flooding or dusting immediately prior to and during the magnetization. Following this, time shall be allowed for indications to form before removal of the magnetic field.

When magnetic suspensions are used, the magnetic field shall be maintained within the object until the majority of the suspension carrier liquid has drained away from the test surface. This will prevent any indications being washed away.

Depending on the material being tested, its surface condition and magnetic permeability, indications will normally remain on the surface even after removal of the magnetic field due to residual magnetism within the part (mainly at the location of the poles). However, the presence of residual magnetism shall not be presumed and post evaluation techniques after removal of the prime magnetic field source are only permitted when a component has been proven by an overall performance test to retain magnetic indications.

5.10 Overall performance test

When specified, an overall performance test of the system sensitivity for each procedure shall be carried out on site. The performance test shall be designed to ensure a proper functioning of the entire chain of parameters including the equipment, the magnetic field strength and direction, surface characteristics, detection media and illumination.

The most reliable test is to use representative test pieces containing real imperfections of known type, location, size and size-distribution. Where these are not available, fabricated test pieces with artificial imperfections or flux shunting indicators of the cross or disc or shim-type may be used.

The test pieces shall be demagnetized and free from indications resulting from previous tests.

NOTE It can be necessary to perform an overall performance test of the system sensitivity for each specific procedure on site.

5.11 False indications

False indications which may mask relevant indications can arise for many reasons, such as changes in magnetic permeability, very important geometry variation in, for example, the heat affected zone. Where masking is suspected, the test surface shall be dressed or alternative test methods should be used.

5.12 Recording of indications

Indications can be recorded in one or more of the following ways by using:

- a) description in writing;
- b) sketches;

- c) photography;
- d) transparent adhesive tape;
- e) transparent varnish for “freezing” the indication on the surface tested;
- f) peelable contrast coating;
- g) video recording;
- h) magnetic particle dispersion in an epoxy curable resin;
- i) magnetic tapes;
- j) electronic scanning.

5.13 Demagnetization

After testing welds with alternating current, residual magnetization will normally be low and there will generally be no need for demagnetization of the object under test.

If demagnetization is required, it shall be carried out using a defined method and to a predefined level.

For metal cutting processes, a typical residual field strength value of $H \leq 0,4$ kA/m is recommended.

5.14 Test report

A test report shall be prepared.

The report should contain at least the following:

- a) name of the company carrying out the test;
- b) the object tested;
- c) date of testing;
- d) parent and weld materials;
- e) any post weld heat treatment;
- f) type of joint;
- g) material thickness;
- h) welding process(es);
- i) temperature of the test object and the detection media (when using media in circulation) throughout testing duration;
- j) identity of the test procedure and description of the parameters used, including the following:
 - type of magnetization;
 - type of current;
 - detection media;
 - viewing conditions;
- k) details and results of the overall performance test, where applicable;
- l) acceptance levels;

ISO 17638:2016(E)

- m) description and location of all recordable indications;
- n) test results with reference to acceptance levels;
- o) names, relevant qualification and signatures of personnel who carried out the test.

Annex A (informative)

Variables affecting the sensitivity of magnetic particle testing

A.1 Surface conditions and preparation

The maximum test sensitivity that can be achieved by any magnetic testing method is dependent on many variables but can be seriously affected by the surface roughness of the object and any irregularities present. In some cases, it can be necessary to

- dress undercut and surface irregularities by grinding, and
- remove or reduce the weld reinforcement.

Surfaces covered with a thin non-ferromagnetic coatings up to 50 µm thickness may be tested provided the colour is contrasting with the colour of the detection medium used. Above this thickness, the sensitivity of the method decreases and may be demonstrated to be sufficiently sensitive before proceeding with the test.

A.2 Magnetizing equipment characteristics

The use of alternating current gives the best sensitivity for detecting surface imperfections.

Yokes produce an adequate magnetic field in simple butt-welds but where the flux is reduced by gaps or the path is excessive through the object, as in T-joints a reduction of sensitivity can occur.

For complex joint configurations, i.e. branch connections with an inclined angle of less than 90°, testing using yokes might be inadequate. Prods or cable wrapping with current flow will, in these cases, prove more suitable.

A.3 Magnetic field strength and permeability

The field strength required to produce an indication strong enough to be detected during magnetic particle testing is dependent mainly on the magnetic permeability of the object.

Generally, magnetic permeability is high in softer magnetic materials, for example, low alloy steels and low in harder magnetic materials, i.e. martensitic steels. Because permeability is a function of the magnetizing current, low permeability materials usually require application of a higher magnetization value than do softer alloys to produce the same flux density. It is essential, therefore, to establish that flux density values are adequate before beginning the magnetic particle testing.

A.4 Detection media

Magnetic particle suspensions will usually give a higher sensitivity for detecting surface imperfections than dry powders.

Fluorescent magnetic detection media usually give a higher test sensitivity than colour contrast media, because of the higher contrast between the darkened background and the fluorescent indication. The sensitivity of the fluorescent method will, nevertheless, decrease in proportion to any increase in the roughness of the surface to which magnetic particles adhere and can cause a disturbing background fluorescence.

Where the background illumination cannot be adequately lowered or where background fluorescence is disturbing, coloured detection media in conjunction with the smoothing effect of a contrast aid will usually give better sensitivity.

Bibliography

- [1] ISO 9712, *Non-destructive testing — Qualification and certification of NDT personnel*
- [2] ISO 12707, *Non-destructive testing — Magnetic particle testing — Vocabulary*
- [3] ISO 17635, *Non-destructive testing of welds — General rules for metallic materials*
- [4] ISO 23278, *Non-destructive testing of welds — Magnetic particle testing — Acceptance levels*

