

---

---

## Textiles — Determination of moisture drying rate

*Textiles — Détermination du taux de séchage*



Reference number  
ISO 17617:2014(E)

© ISO 2014



**COPYRIGHT PROTECTED DOCUMENT**

© ISO 2014

All rights reserved. Unless otherwise specified, no part of this publication may be reproduced or utilized otherwise in any form or by any means, electronic or mechanical, including photocopying, or posting on the internet or an intranet, without prior written permission. Permission can be requested from either ISO at the address below or ISO's member body in the country of the requester.

ISO copyright office  
Case postale 56 • CH-1211 Geneva 20  
Tel. + 41 22 749 01 11  
Fax + 41 22 749 09 47  
E-mail [copyright@iso.org](mailto:copyright@iso.org)  
Web [www.iso.org](http://www.iso.org)

Published in Switzerland

# Contents

	Page
<b>Foreword</b> .....	<b>iv</b>
<b>Introduction</b> .....	<b>v</b>
<b>1 Scope</b> .....	<b>1</b>
<b>2 Normative reference</b> .....	<b>1</b>
<b>3 Terms and definitions</b> .....	<b>1</b>
<b>4 Principle</b> .....	<b>1</b>
<b>5 Reagents</b> .....	<b>2</b>
<b>6 Materials and apparatus</b> .....	<b>2</b>
6.4 Method A1 testing apparatus.....	2
6.5 Method A2 testing apparatus.....	3
6.6 Method B testing apparatus.....	3
<b>7 Preparation</b> .....	<b>4</b>
7.1 Conditioning and testing atmosphere.....	4
7.2 Preparation of specimen.....	5
<b>8 Validation test</b> .....	<b>5</b>
<b>9 Testing procedure</b> .....	<b>5</b>
9.1 Method A.....	5
9.2 Method B: Horizontal drying.....	6
<b>10 Calculation</b> .....	<b>7</b>
10.1 Remaining water mass loss, $W_t$ .....	7
10.2 Linear approximation formula.....	7
<b>11 Test report</b> .....	<b>8</b>
<b>Annex A (normative) Validation test for water absorption test</b> .....	<b>9</b>
<b>Annex B (normative) Example of calculation for drying rate</b> .....	<b>12</b>
<b>Annex C (informative) Round robin test results</b> .....	<b>14</b>
<b>Annex D (informative) An example of interpretation for test result</b> .....	<b>23</b>
<b>Bibliography</b> .....	<b>24</b>

## Foreword

ISO (the International Organization for Standardization) is a worldwide federation of national standards bodies (ISO member bodies). The work of preparing International Standards is normally carried out through ISO technical committees. Each member body interested in a subject for which a technical committee has been established has the right to be represented on that committee. International organizations, governmental and non-governmental, in liaison with ISO, also take part in the work. ISO collaborates closely with the International Electrotechnical Commission (IEC) on all matters of electrotechnical standardization.

The procedures used to develop this document and those intended for its further maintenance are described in the ISO/IEC Directives, Part 1. In particular the different approval criteria needed for the different types of ISO documents should be noted. This document was drafted in accordance with the editorial rules of the ISO/IEC Directives, Part 2 (see [www.iso.org/directives](http://www.iso.org/directives)).

Attention is drawn to the possibility that some of the elements of this document may be the subject of patent rights. ISO shall not be held responsible for identifying any or all such patent rights. Details of any patent rights identified during the development of the document will be in the Introduction and/or on the ISO list of patent declarations received (see [www.iso.org/patents](http://www.iso.org/patents)).

Any trade name used in this document is information given for the convenience of users and does not constitute an endorsement.

For an explanation on the meaning of ISO specific terms and expressions related to conformity assessment, as well as information about ISO's adherence to the WTO principles in the Technical Barriers to Trade (TBT) see the following URL: [Foreword - Supplementary information](#)

The committee responsible for this document is ISO/TC 38, *Textiles*.

.....

## Introduction

In addition to traditional clothing, such as shirting made from cotton or polyester/cotton, speciality textile materials have been introduced to the market for use in sportswear, active wear, and leisurewear. The size of the market for this type of clothing has been growing and is expected to continue to grow as the global economy grows.

In a developing market, existing methods of evaluation for such specialist clothing are somewhat limited and new methods of test have not yet been developed to measure specific properties which form the basis of specialist claims.

This International Standard describes three new test methods for measuring the moisture drying rate of textile materials and which are intended to reflect the drying characteristics of the textile after it has become dampened with perspiration (sweat) due to the wearer being engaged in light sport or active living situations.

These test methods can also be applied to other textile materials for which moisture drying rates are required to be determined.

Although three test methods are described in this International Standard, the concerned parties should agree on the most appropriate method of test to be used.

Copyright International Organization for Standardization

# Textiles — Determination of moisture drying rate

## 1 Scope

This International Standard specifies a testing method for evaluating the moisture-drying properties of all types of textile fabric. The method is not suitable for determining a drying rate on textiles in other forms such as loose fibre or yarn.

## 2 Normative reference

The following documents, in whole or in part, are normatively referenced in this document and are indispensable for its application. For dated references, only the edition cited applies. For undated references, the latest edition of the referenced document (including any amendments) applies.

ISO 139, *Textiles — Standard atmospheres for conditioning and testing*

ISO 3696, *Water for analytical laboratory use — Specification and test methods*

## 3 Terms and definitions

For the purposes of this document, the following terms and definitions apply.

### 3.1

#### **drying rate (DR)**

length of time required to dry a known mass of moisture from a textile fabric

Note 1 to entry: It is expressed in drying percent per unit time.

### 3.2

#### **drying time (100 %)**

time for which 100 % of applied water loss occurs

## 4 Principle

A specified quantity of moisture is applied to a specimen and the weight of moisture remaining on the specimen after a specific period of time is measured. The drying rate and/or specific drying rate is calculated by linear regression of time against residual moisture content.

Two methods of test are given — vertical drying (Method A) and horizontal drying (Method B).

In Method A1, a specimen is hung vertically on a frame which is suspended beneath a balance, while in Method A2 a specimen is placed on a top-pan balance. In both of these methods, the specimens are exposed to the test environment on both sides. In Method B, a specimen is laid flat in a dish which is placed on a top pan balance and the specimen is only exposed to the environment on its uppermost surface. The results obtained by the two vertical drying methods (A1 and A2) are comparable but the results obtained using the horizontal drying method (B) are not comparable with those obtained using either vertical drying method.

**NOTE** For the purposes of this test method, water is taken as being representative of all types of body fluids into which the textile fabric might come into contact. This includes perspiration, saliva, or urine.

The test procedures for each of the three separate test methods are given in this International Standard. It is for the interested parties to agree on the most appropriate method to be used.

Method B is particularly suited for textile fabrics with good surface wetting or capillary (wicking) properties.

## 5 Reagents

5.1 **Grade 3 water**, as specified in ISO 3696.

NOTE Alternative liquids, such as artificial perspiration solution, can be substituted with the agreement of the parties. A chemical formulation for artificial perspiration solution is given in ISO 105-E04.

## 6 Materials and apparatus

6.1 **Micro pipette**, capable of dispensing the required volume of water to an accuracy of 0,01 ml.

6.2 **Petri dish**, made of glass with internal diameter at least 5 mm larger than the diameter of the test specimen and with an internal height of  $20 \text{ mm} \pm 3 \text{ mm}$ .

NOTE If validation is obtained, the other materials could be used.

6.3 **Balance**, with a suitable capacity and a resolution of 0,001 g. The full scale range of the balance shall be such that the total mass of the test assembly (test specimen plus supporting frame) falls between 10 % and 90 % of the full scale range of the balance.

For Method A1, the balance shall be equipped with the facility to suspend the test frame beneath the balance as shown in [Figure 1](#). For Method A2 and Method B, the balance shall be capable of supporting the test frame or petri dish on the top pan.

### 6.4 Method A1 testing apparatus

A schematic diagram of the apparatus is shown in [Figure 1](#).

6.4.1 Hanger equipped with suitable means of mounting the test specimen (e.g. hooks, pins, or clips) and fitted with a means of being suspended below the balance ([6.3](#)), as shown in [Figure 1](#). The materials used shall not be water absorbent.

6.4.2 Enclosure, open ended and of suitable dimensions so as to enclose the suspended test assembly and shall extend to at least 50 mm below the lowest edge of the suspended test specimen.

NOTE The enclosure can be made of any material such as glass, acrylic, etc. The dimensions will be dependent upon the dimensions of the balance ([6.3](#)) but a suitable size has been found to be at least 300 mm (width) by 300 mm (depth) by 300 mm (height).

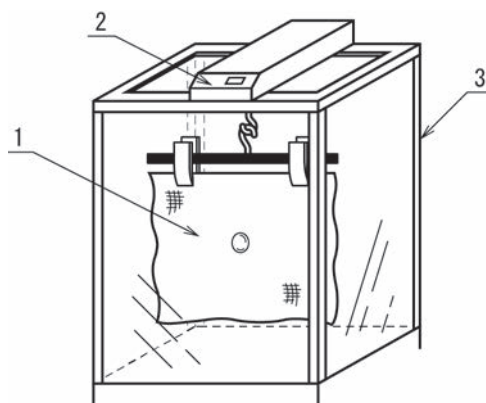

#### Key

- 1 specimen
- 2 balance



3 hanger with clips

**Figure 1 — Method A1 testing apparatus**

## 6.5 Method A2 testing apparatus

A schematic diagram of the apparatus is shown in [Figure 2](#).

**6.5.1** Hanger equipped with suitable means of mounting the test specimen (e.g. hooks, pins, or clips) and fitted with a means of being supported on the top pan of the balance ([6.3](#)) and within the test enclosure ([6.5.2](#)) as shown in [Figure 2](#). The materials used shall not be water absorbent.

**6.5.2** Enclosure made of any suitable non-water absorbent material and of suitable dimensions so as to enclose the balance and the test assembly. The height of the enclosure shall be at least 50 mm greater than the overall height of the test assembly when placed on the top pan of the balance. The enclosure shall be open on two opposing faces and on the face directly above the test specimen.

**NOTE** Many commercially available balances are already equipped with enclosures which have appropriate sliding panels.

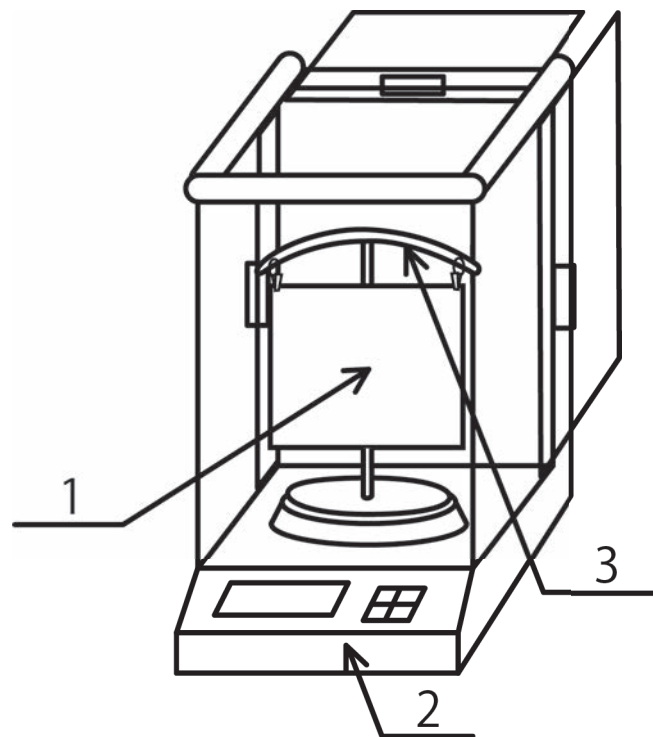

### Key

- 1 specimen
- 2 balance
- 3 hanging frame

**Figure 2 — Method A2 testing apparatus**

## 6.6 Method B testing apparatus

A schematic diagram of the apparatus is shown in [Figure 3](#).

6.6.1 Enclosure made of any suitable material comprising four walls and without a ceiling. The enclosure shall be of sufficient dimensions to enclose the balance (6.3) and the height shall be at least 50 mm greater than the plane of the upper surface of the petri dish containing the test specimen.

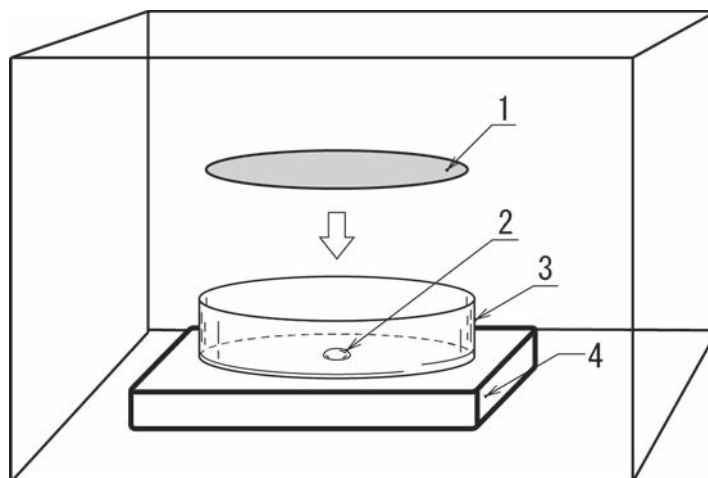

**Key**

- 1 specimen
- 2 moisture
- 3 petri dish
- 4 balance

**Figure 3 — Method B testing apparatus**

6.7 **Anemometer**, capable of measuring air speed to an accuracy of 0,01 m/s.

6.8 **Timing device**, with accuracy of  $\pm 1$  s.

6.9 **Water applying frame**, comprising a means of holding a sample of fabric in a horizontal plane above the supporting bench top surface and which leaves a central area of the test specimen of approximately 100 mm diameter exposed to the environment.

NOTE Annular rings, such as embroidery rings, rectangular plates with a central orifice and equipped with clips or pins have been found to be suitable. Alternatively, samples can be supported in the hand but particular attention is required to avoid transfer of moisture or contamination to or from the skin surface.

6.10 **Plastic gloves**.

## 7 Preparation

### 7.1 Conditioning and testing atmosphere

The test specimens shall be conditioned in the standard atmosphere at a temperature of 20 °C and a relative humidity of 65 % as defined in ISO 139 for at least 24 h.

Testing shall be carried out in the conditioned environment as above and in a location which is substantially draught free (i.e. the air velocity across the exposed face(s) of the test specimen shall not exceed 0,1 m/s).

The air velocity shall be measured immediately prior to commencing each sequence of testing using an anemometer (6.7).

## 7.2 Preparation of specimen

### 7.2.1 Sampling

### 7.2.2 Number and dimension of test specimen

Prepare one test specimen for the validation test and three further test specimens for the drying rate tests. The dimensions of the test specimens shall be as given in [Table 1](#).

Whenever manual handling of the test specimens is necessary, it is recommended that non-absorbent gloves are worn to avoid any unintentional transfer or loss of moisture or contamination between the test specimen and skin surface.

**Table 1 — Typical dimension of specimen for the test**

Test method		Method A (unit: mm)		Method B (Diameter: mm)
		Method A1: sus- pending	Method A2: top pan	
Dimension	Specimen for drying test	Square: $(200 \pm 2) \times$ $(200 \pm 2)$	Square: $(100 \pm 2) \times$ $(100 \pm 2)$	Circular: $85 \pm 2$

Alternative size test specimens are permitted provided that any wicking does not extend to within 10 mm of any edge of the test specimen.

### 7.2.3 Conditioning of specimens

Prior to test, samples shall be conditioned in the conditioning atmosphere ([7.1](#)) for a minimum of 24 h.

### 7.2.4 Conditioning of water

Keep the water in the testing condition ([7.1](#)) for at least for 24 h. The water used in the test shall be at a temperature of  $(20 \pm 2)^\circ\text{C}$ .

## 8 Validation test

Prior to carrying out the test, conduct the validation test as described in [Annex A](#). Samples shall have an absorption time of less than or equal to 60 s. Samples with an absorption time of greater than 60 s are not suitable for testing using the methods described in this International Standard. The average absorption time obtained shall be recorded in the test report.

## 9 Testing procedure

### 9.1 Method A

Method A is a vertical drying method using either of two configurations — Method A1: suspension method (see [6.4](#) and [Figure 1](#)) or Method A2: top pan method (see [6.5](#) and [Figure 2](#)).

**9.1.1** Prepare suspension hangers ([6.4](#)) for Method A or hanging frames ([6.5](#)).

**9.1.2** Attach the test specimen to a suspension hanger (Method A1) or to a hanging frame (Method A2).

**9.1.3** For Method A1, attach the suspension hanger complete with test specimen to the hook of the balance. For Method A2, place the holding frame complete with test specimen on the top pan of the

balance. Weigh the complete assembly to the nearest 0,001 g and record with mass as the mass before application ( $M_w$ ).

**9.1.4** Remove the suspension hanger (Method A1) or holding frame (Method A2) from the balance before removing the test specimen from the suspension frame or holding frame.

**9.1.5** Lay the test specimen horizontally on the water applying frame (6.9) so that the central portion of the underside of the test specimen is not in contact with any surface and the surface to be tested is uppermost.

**9.1.6** For Method A1, apply 0,30 ml  $\pm$  0,01 ml of conditioned water to the approximate centre of the exposed upper surface of the test specimen using the micropipette (6.1).

If leakage occurs, record it in the report. When leakage occurs, the effectiveness of the test should be judged by the concerned parties.

**9.1.7** For Method A2, apply 0,08 ml  $\pm$  0,01 ml of conditioned water to the approximate centre of the exposed upper surface of the test specimen using the micropipette (6.1).

If leakage occurs, record it in the report. When leakage occurs, the effectiveness of the test should be judged by the concerned parties.

**9.1.8** Remove the test specimen from the water applying frame (6.9) and re-attach the test specimen to the suspension frame (Method A1) or the hanging frame (Method A2) and return the test assembly to the balance. This shall be completed within 60 s of the water being absorbed into the surface of the test specimen. Weigh the test assembly to the nearest 0,001 g and immediately start the timing device (6.8). Record the mass of the assembly as  $M_0$ .

**9.1.9** Repeat the measurement of the mass of the test assembly at intervals of 5 min  $\pm$  15 s, until either a total of 60 min has elapsed or until the remaining water mass falls to within 10 % of the initial water mass. Record the mass of the test assembly as each interval  $t$  as  $M_t$  where  $t$  is the time elapsed in minutes.

**9.1.10** Repeat the test on the remaining two test specimens.

It is permissible to carry out concurrent tests on all three samples provided that separate suspension frames or holding frames are used for each test specimen.

**9.1.11** Calculate the drying rate in accordance with [Clause 10](#).

**9.1.12** Determine the mean drying rate from the three individual test results obtained in [9.1.11](#).

## 9.2 Method B: Horizontal drying

This method uses the apparatus as described in [6.6](#) and [Figure 3](#).

**9.2.1** Place the test specimen in the base of the petri dish (6.2) so that the test specimen lays flat. Place the test assembly on the balance and measure the mass to the nearest 0,001 g. Record the mass as the mass of the assembly before test ( $M_w$ ).

**9.2.2** Remove the test specimen assembly from the petri dish. Apply (0,1  $\pm$  0,01) ml of water using a micropipette to the centre of the base of the petri dish and replace the test specimen with the surface to be tested face down and in contact with the water. Immediately start a timing device (6.8) and re-weigh the test assembly to the nearest 0,001 g and record this mass as  $M_0$ .

It is preferable not to remove the petri dish from the balance in order to apply the water.

**9.2.3** If the water applied spreads (wicks) to the within 10 mm of the edge of the test specimen then the test is invalid and should be repeated using a larger sample. If this is not possible, then the test sample is unsuitable for testing using this method.

**9.2.4** Repeat the measurement of the mass of the test assembly at intervals of 5 min  $\pm$  15 s, until either a total of 60 min has elapsed or until the remaining water mass falls to within 10 % of the initial water mass. Record the mass of the test assembly as each interval  $t$  as  $M_t$  where  $t$  is the time elapsed in minutes.

**9.2.5** Repeat the test on the remaining two test specimens.

It is permissible to carry out concurrent tests provided that separate petri dishes are used for each test specimen and that each test specimen is maintained within an environment such that it is essentially draught-free (see [7.1](#)).

**9.2.6** Calculate the drying rate in accordance with [Clause 10](#).

**9.2.7** Determine the mean drying rate from the three individual test results obtained in [9.2.6](#).

## 10 Calculation

### 10.1 Remaining water mass loss, $W_t$

Tabulate the mass loss of water remaining in the test specimen ( $W_t$ ) against time elapsed ( $t$ ) for each interval at which a measurement was made as shown in Formula (1):

$$W_t = M_0 - M_t \quad (1)$$

where

$M_0$  is the mass of the test assembly at  $t = 0$ ;

$M_t$  is the mass of the test assembly at time  $t$ .

Then the percentage of drying mass,  $L_t$ , is calculated as in Formula (2):

$$L_t = \frac{W_t}{M_0 - M_w} \times 100(\%) \quad (2)$$

where

$W_t$  is the remaining water mass loss at time  $t$ ;

$M_w$  is the mass of the test assembly just before water application.

### 10.2 Linear approximation formula

**10.2.1** Using the data calculated in [10.1](#), as an example used % loss, determine the slope ( $a$ ) of the drying curve (in %/min) using the least squares difference regression (see [Annex B](#)) such that the y-intercept equals zero and using the time elapsed as the x-values and the mass of water lost as the y-values, as shown in Formula (3).

$$y = ax + b \quad (3)$$

where

- $y$  is the percentage loss of water mass;
- $a$  is the slope, drying rate (DR) (%/min);
- $x$  is the time to dry (actually,  $t$ );
- $b$  is the constant.

**10.2.2** Calculate the drying rate, DR, as shown in Formula (4) and Formula (5).

$$\text{DR} = a \quad (4)$$

$$a = \frac{y - b}{x} \quad (5)$$

**10.2.3** Calculate the drying time for 100 % dry or, if required, the drying time for specific % as follows:

For 100 % drying time as in Formula (6),

$$\text{Drying time (100\%)} = (100 - b) / a \quad (6)$$

For  $y$  % drying time as in Formula (7),

$$\text{Drying time (}y\%\text{)} = (y - b) / a \quad (7)$$

## 11 Test report

The test report shall contain the following:

- a) reference to this International Standard (i.e. ISO 17617);
- b) details of the sample tested;
- c) test method (Method A1 or A2, Method B) used;
- d) validation result for absorption test with time;
- e) nominal mass of the applied water (0,3 g, 0,08 g, or 0,1 g);
- f) drying rate (%/min) or drying time (100 %);
- g) drying time for specific drying %, if required;
- h) any deviation from this International Standard.

## Annex A (normative)

### Validation test for water absorption test

#### A.1 General

This validation test is intended as a means of differentiating between samples which will absorb water and those which will not. Samples which will not absorb water cannot be tested using the methods described in this International Standard.

#### A.2 Apparatus

**A.2.1 Micropipette**, capable of throughput of 0,03 ml with tolerance of  $\pm 0,01$  ml.

**A.2.2 Stopwatch**.

**A.2.3 Specimen holder**, made of water resistant materials and capable of supporting the test specimen horizontally above the surface on which the holder is placed. The central area of the holder shall be at least 150 mm in diameter.

NOTE Embroidery rings of appropriate dimensions which satisfy this requirement are readily available. Alternatively, frames with pins or clips around the circumference can also be used, provided that the frame meets the requirements with regards to the central exposed area.

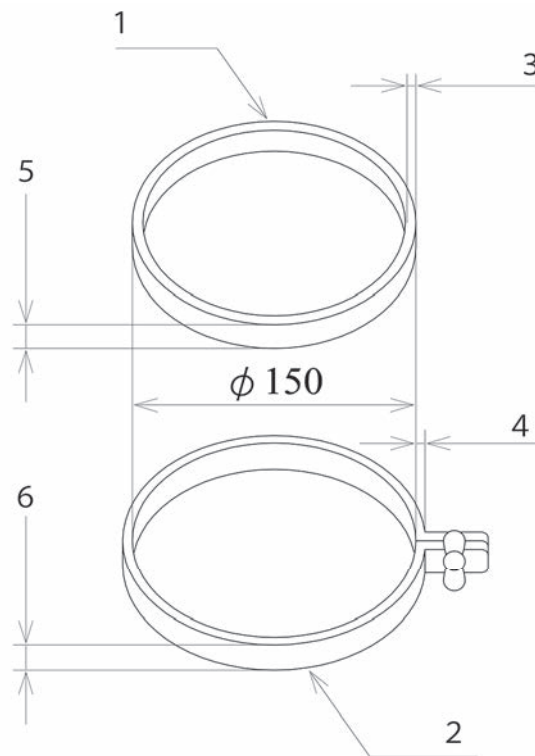

**Key**

- 1 specimen inner holding frame
- 2 specimen outer holding frame
- 3, 4 thickness of frame: about 2 mm
- 5, 6 frame height: about 15 mm

**Figure A.1 — Specimen holding frame**

**A.3 Specimen dimension**

(200 ± 2) mm by (200 ± 2) mm

**A.4 Testing procedure**

**A.4.1** Set up the position of the lighting, specimen, and operator as operator can observe specular reflection of water droplet on the surface of the specimen.

As an example, the lighting and observation positions may refer to BS 4554.

**A.4.2** Place and set a validation specimen on the specimen holding frame (see [Figure A.1](#)).

**A.4.3** Apply one water droplet of 0,03 ml ± 0,01 ml on a specimen by micropipette from approximately 1 cm above a specimen .

**A.4.4** Immediately push the stopwatch start button.

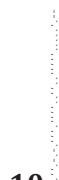



**A.4.5** Observe the wet surface and push the stopwatch stop button when specular reflection of water disappear.

As the illuminant aids the observer in determining when the droplet of water has been absorbed, the illumination and observer should be on opposite sides of the droplet and at angles of 45° to the plane of the test specimen.

**A.4.6** Read a time for absorption of water droplet.

**A.4.7** Repeat the test at a further four locations on the test specimen taking care to ensure that each test is positioned sufficiently distant from the previous tests so as to avoid any interference with the absorption from previously wetted areas of the test specimen. If necessary, separate or additional test specimens may be used

After several tests, if there is no dry surface on the specimen because of good wettability, reduce the number of tests.

**A.4.8** Determine the mean of the five test measurements to the nearest 1 s and record this as the absorption time.

## Annex B (normative)

### Example of calculation for drying rate

#### B.1 Calculation of drying rate

##### B.1.1 Test method used

Vertical drying method A1 using a nominal water application of 0,3 ml.

##### B.1.2 Test result

[Table B.1](#) shows the test results for one specimen.

Mass of hanger frame (FM): 52,750 g

Mass of hanger frame + dry test specimen (DM): 53,750 g

**Table B.1 — Example of calculation for drying rate**

Drying time (t) min	Specimen + hanger mass	Wet mass of test specimen	Mass of water	Mass loss	
	<i>Mt</i> gram	<i>Mt-FM</i> gram	<i>Mt-DM</i> gram	<i>Wt</i> gram	<i>Lt</i> %
0	54,047	1,297	0,297	0,000	0
5	54,009	1,259	0,259	0,038	12,8
10	53,958	1,208	0,208	0,089	30,0
15	53,912	1,162	0,162	0,135	45,5
20	53,867	1,117	0,117	0,180	60,6
25	53,826	1,076	0,076	0,221	74,4
30	53,785	1,035	0,035	0,262	88,2
35 <sup>a</sup>	53,756	1,006	0,006	0,291	98,0
40 <sup>a</sup>					
45 <sup>a</sup>					
50 <sup>a</sup>					
55 <sup>a</sup>					
60 <sup>a</sup>					

<sup>a</sup> Data with *Lt* over 90 % are discarded.

Mass of water at 0 min =  $M_0 - DM = 54,047 - 53,750 = 0,297$

Wet mass of test specimen at 0 min =  $M_0 - FM = (54,047 - 52,750) = 1,297$

Plot mass loss % versus time is shown in [Figure B.1](#).

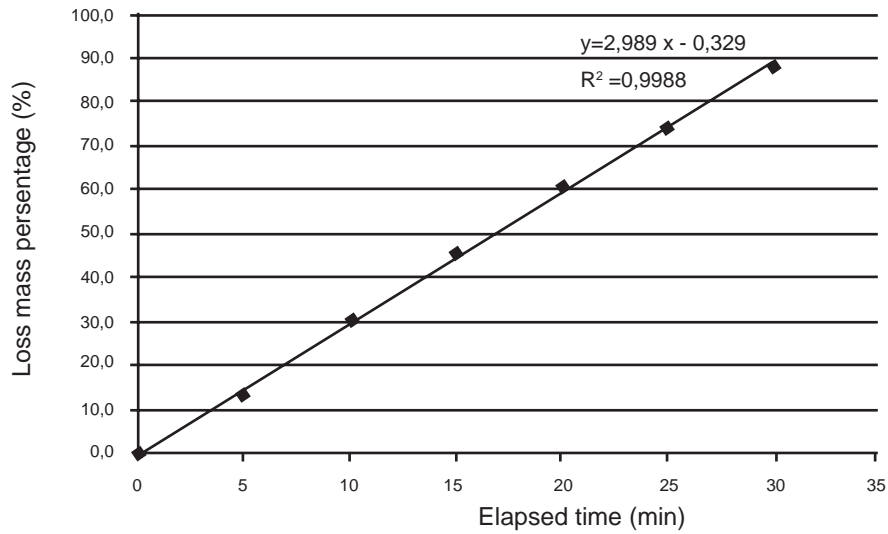

**Figure B.1 — Example of the graph of the loss in mass of water % versus time**

Drying time (100 %) =  $(100 + 0,329) / 2,989 = 33,6$  min

As the volume of water applied was greater than 90 % of applied water amount, no correction is required to the drying time.

The drying times for the two other test specimens were 36,1 min and 36,6 min.

The standard deviation is 1,73 min and the coefficient of variation is 4,9 %.

## Annex C (informative)

### Round robin test results

#### C.1 Test sample

- Sample 1: Mesh T shirt: Polyester 100 % knitted fabric
- Sample 2: T shirt: Polyester 60 % cotton 40 % woven fabric
- Sample 3: White shirt: Polyester 40 % cotton 60 % woven fabric
- Sample 4: T shirt: Polyester 23 % cotton 77 % knitted fabric
- Sample 5: 50 % Polyester, 50 % Cotton. Knitted fabric. 178.6g/sq.m
- Sample 6: 70 % Polyester, 30 % Cotton. Knitted fabric. 197.8g/sq.m
- Sample 7: 100 % Polyester. Knitted fabric. 170.0g/sq.m

#### C.2 Testing method used

- Method A1
- Method B
- Method A2

#### C.3 Test result

##### C.3.1 Vertical method A1 test results

Testing houses of A, B, and C use Method A1. The linear approximation formula is omitted.

Test results for samples using Method B drying test are shown in [Table C.1](#), [Table C.2](#), [Table C.3](#), and [Table C.4](#).

NOTE For the linear approximation, an application software was used and calculated to three or four decimal places and round up to significant figures of three.

**Table C.1 — Method A1 drying test result for sample 1**

Time (min): x	Testing house (TH): Data: Loss % in water mass Lt: (y)								
	A			B			C		
0	0,0	0,0	0,0	0,0	0,0	0,0	0,0	0,0	0,0
5	13,5	12,7	13,8	12,9	10,0	6,7	10,3	10,3	10,7
10	29,6	29,0	30,2	22,6	20,0	20,0	22,0	22,0	21,8
15	46,1	45,3	47,0	35,5	30,0	33,3	33,3	34,7	33,9
20	62,6	61,7	63,1	45,2	43,3	46,7	44,7	46,3	45,0
25	78,8	77,7	79,5	58,1	53,3	56,7	55,7	58,3	56,7
30	92,9	91,7	91,9	67,7	63,3	66,7	66,7	69,7	67,8

Table C.1 (continued)

Time (min): x	Testing house (TH): Data: Loss % in water mass Lt: (y)								
	A			B			C		
35		99,3	99,3	77,4	76,7	80,0	77,0	79,7	78,2
40		99,7		87,1	86,7	86,7	86,0	88,3	87,6
45				93,5	93,3	96,7	93,0	94,3	94,3
50							97,3	98,0	99,0
55							99,0	98,3	99,7
60							99,0	98,3	99,7
DR(slope, a) (%/min)	3,19	3,15	3,21	2,29	2,15	2,38	2,24	2,36	2,28
Constant, b	-1,41	-1,68	-1,25	+0,45	-2,54	-1,48	-3,8	-0,84	-0,43
Drying time (100 %) (min)	31,8	32,3	31,5	43,5	46,8	43,1	44,7	42,8	44,1
Average drying time within TH (min)	31,9			44,5			43,9		
STD within TH	0,38			2,05			0,99		
CV% within TH	1,20			4,62			2,25		
Average drying time among TH (min)	40,1								
STD among TH	7,12								
CV% among TH	17,8								

Table C.2 — Method A1 drying test result for sample 2

Time (min): x	Testing house (TH): Data: Loss % in water mass Lt: (y)								
	A			B			C		
0	0,0	0,0	0,0	0,0	0,0	0,0	0,0	0,0	0,0
5	11,5	11,6	12,0	10,3	13,3	10,0	9,0	9,1	8,3
10	25,3	25,9	27,5	24,1	23,3	20,0	19,0	19,5	17,6
15	39,8	40,9	44,4	34,5	33,3	33,3	29,0	29,9	27,2
20	54,6	55,1	60,9	44,8	43,3	43,3	39,3	39,9	36,9
25	69,4	70,1	76,4	58,6	56,7	53,3	48,7	49,0	47,2
30	82,6	83,7	89,8	72,4	66,7	66,7	58,7	59,7	56,8
35		94,0	98,2	79,3	76,7	76,7	68,3	68,8	66,1
40		100,0		89,7	86,7	86,7	76,7	77,5	74,8
45				96,6	96,7	93,3	84,0	84,6	82,7
50							90,3	91,3	89,4
55							94,7	95,3	94,0
60							97,0	97,0	97,0
DR(slope, a) (%/min)	2,81	2,84	3,08	2,29	2,16	2,20	1,91	1,92	1,84
Constant, b	-1,62	-1,52	-1,84	0,23	1,33	-0,67	0,32	0,55	0,02
Drying time (100 %) (min)	36,2	35,8	33,0	43,6	45,8	45,8	52,2	51,7	54,3
Average drying time within TH (min)	35,0			45,0			52,7		
STD within TH	1,73			1,24			1,33		
CV% within TH	4,94			2,75			2,53		

Table C.2 (continued)

Time (min): x	Testing house (TH): Data: Loss % in water mass Lt: (y)		
	A	B	C
Average drying time among TH (min)	44,3		
STD among TH	8,89		
CV% among TH	20,1		

Table C.3 — Method A1 drying test result for sample 3

Time (min): X	Testing house (TH): Data: Loss % in water mass Lt: (y)								
	A			B			C		
0	0,0	0,0	0,0	0,0	0,0	0,0	0,0	0,0	0,0
5	22,4	22,1	23,5	13,8	13,3	13,3	16,9	16,5	16,5
10	45,8	46,8	48,5	31,0	30,0	30,0	32,8	32,7	33,0
15	70,2	70,2	72,7	44,8	43,3	43,3	49,7	48,8	49,8
20	91,2	90,0	92,2	62,1	60,0	60,0	65,2	63,6	65,7
25				75,9	73,3	73,3	79,8	78,5	79,5
30				89,7	83,3	83,3	90,7	89,9	90,1
35				96,6	93,3	93,3	95,4	95,3	95,7
40					96,7	96,7	96,4	96,6	97,0
45							96,7	97,0	97,4
50							96,7	97,0	97,7
55							96,7	97,0	97,7
60							97,0	97,0	98,0
DR(slope, a) (%/min)	4,68	4,71	4,86	3,03	2,93	2,93	3,21	3,03	3,21
Constant, b	-0,51	0,54	-0,27	-0,34	-0,33	-0,33	0,66	1,65	0,61
Drying time (100 %) (min)	21,5	21,1	20,6	33,1	34,2	34,2	31,0	32,4	30,9
Average drying time within TH (min)	21,1			33,8			31,5		
STD within TH	0,43			0,66			0,84		
CV% within TH	2,03			1,94			2,68		
Average drying time among TH (min)	28,8								
STD among TH	6,78								
CV% among TH	23,5								

Table C.4 — Method A1 drying test result for sample 4

Time (min): X	Testing house (TH): Data: Loss % in water mass Lt: (y)								
	A			B			C		
0	0,0	0,0	0,0	0,0	0,0	0,0	0,0	0,0	0,0
5	12,8	12,1	13,2	6,7	10,0	6,7	9,8	8,6	7,3
10	30,0	27,2	26,6	13,3	16,7	13,3	18,9	18,2	16,6
15	45,5	41,3	41,1	23,3	23,3	23,3	27,9	27,7	25,8
20	60,6	56,0	55,9	30,0	33,3	30,0	36,7	37,6	35,4
25	74,4	70,1	68,4	40,0	40,0	36,7	45,8	46,9	44,0

Table C.4 (continued)

Time (min): X	Testing house (TH): Data: Loss % in water mass Lt: (y)								
	A			B			C		
30	88,2	82,2	80,6	46,7	50,0	46,7	54,5	56,4	53,0
35		93,0	90,5	56,7	56,7	56,7	62,6	65,3	61,6
40		100,0		63,3	66,7	63,3	70,4	73,3	69,9
45				73,3	76,7	73,3	77,4	80,2	77,8
50							83,8	86,1	84,1
55							88,9	91,1	89,7
60							92,6	94,1	93,0
DR(slope, a) (%/min)	2,99	2,80	2,73	1,64	1,66	1,64	1,65	1,78	1,69
Constant, b	-0,35	-0,68	-0,05	-1,58	-0,12	-1,82	2,81	1,10	0,66
Drying time (100 %) (min)	33,6	36,0	36,7	61,9	60,1	62,2	59,1	55,7	58,8
Average drying time within TH (min)	35,4			61,4			57,9		
STD within TH	1,65			1,12			1,87		
CV% within TH	4,64			1,82			3,24		
Average drying time among TH (min)	51,6								
STD among TH	14,10								
CV% among TH	27,3								

### C.3.2 Method B drying test

Six testing houses from Japan participated in this round robin test.

Test results for samples using Method B drying test are shown in [Table C.5](#), [Table C.6](#), [Table C.7](#), and [Table C.8](#).

Table C.5 — Method B drying test result for sample 1

Time(min): X	Testing house (TH): Data: Loss % in water mass Lt: (y)																	
	A			B			C			D			E			F		
0	0,0	0,0	0,0	0,0	0,0	0,0	0,0	0,0	0,0	0,0	0,0	0,0	0,0	0,0	0,0	0,0	0,0	0,0
5	10,0	10,3	9,1	29,1	31,7	32,7	11,0	12,9	12,0	11,0	11,2	11,1	12,7	12,6	12,6	14,9	8,3	16,0
10	19,0	22,7	18,2	42,7	46,2	48,1	24,0	27,7	25,0	23,0	23,5	22,2	25,5	21,4	22,3	30,7	20,8	32,0
15				56,3	60,6	62,5	36,0	41,6	39,0	33,0	32,7	32,3	31,4	27,2	35,0			
20	39,0	39,2	35,4	68,9	76,0	76,9	48,0	55,4	51,0	42,0	41,8	40,4	52,9	34,0	45,6	59,4	52,1	63,0
25				81,6	88,5	89,4	60,0	69,3	63,0	53,0	53,1	51,5	64,7	42,7	58,3			
30	56,0	58,8	53,5	92,2	98,1	97,1	71,0	78,2	76,0	65,0	64,3	64,6	76,5	53,4	67,0	86,1	82,3	85,0
35				99,0	99,0	99,0	81,0	90,1	87,0	74,0	74,5	73,7	85,3	64,1	78,6			
40		78,4		99,0	99,0	98,1	90,0	95,0	95,0	82,0	81,6	80,8	95,1	71,8	88,3	99,0	99,0	
45				99,0	98,1	97,0	98,0	99,0	88,0	87,8	86,9							
50							96,0	99,0	95,0	94,9	94,9							
55							96,0		98,0	99,0	99,0							
60							96,0											
DR(slope, a) (%/min)	1,88	1,93	1,78	3,09	3,37	3,40	2,35	2,68	2,51	2,00	1,99	1,98	2,51	1,74	2,21	2,88	2,82	2,87

Table C.5 (continued)

Time(min): X	Testing house (TH): Data: Loss % in water mass Lt: (y)																	
	A			B			C			D			E			F		
Constant, b	0,41	1,04	0,14	7,81	8,38	9,16	0,25	0,53	0,17	2,07	2,21	1,76		1,60	1,04	0,80		1,95
Drying time (100 %) (min)	53,1	51,2	56,2	29,8	27,2	26,8	42,4	37,1	39,7	48,9	49,1	49,6	39,9	56,6	44,7	34,5	36,9	34,2
Average drying time within TH (min)	53,5			27,9			39,8			49,2			47,1			35,2		
STD within TH	2,54			1,66			2,67			0,33			8,59			1,47		
CV% within TH	4,76			5,95			6,71			0,67			18,24			4,18		
Average drying time among TH (min)	42,1																	
STD among TH	9,58																	
CV% among TH	22,8																	

Table C.6 — Method B drying test result for sample 2

Time(min): X	Testing house (TH): Data: Loss % in water mass Lt: (y)																	
	A			B			C			D			E			F		
0	0,0	0,0	0,0	0,0	0,0	0,0	0,0	0,0	0,0	0,0	0,0	0,0	0,0	0,0	0,0	0,0	0,0	0,0
5	11,2	8,1	7,2	13,6	20,2	13,6	10,0	8,9	8,9	7,1	7,1	6,1	12,0	14,6	10,7	10,0	10,0	10,0
10	22,4	21,2	19,6	21,4	29,8	21,4	24,0	22,8	19,8	17,3	16,2	16,2	18,0	21,4	19,4	22,0	22,0	22,0
15				29,1	41,3	30,1	36,0	34,7	31,7	27,6	27,3	26,3	31,0	34,0	36,9			
20	46,9	46,5	42,3	36,9	50,0	37,9	49,0	47,5	44,6	37,8	36,4	35,4	45,0	47,6	44,7	50,0	47,0	47,0
25				44,7	61,5	46,6	60,0	58,4	54,5	45,9	45,5	43,4	52,0	59,2	57,3			
30	72,4	70,7	66,0	53,4	70,2	54,4	71,0	70,3	66,3	56,1	55,6	53,5	68,0	68,9	68,9	73,0	70,0	71,0
35				61,2	78,8	62,1	80,0	81,2	75,2	67,3	66,7	64,6	76,0	82,5	78,6			
40		89,9		68,0	86,5	69,9	90,0	87,1	83,2	76,5	75,8	74,7	84,0	90,3	84,5	92,0	90,0	
45					93,3	76,7	93,0	93,1	91,1	84,7	83,8	80,8						
50								97,0	97,0	90,8	90,9	86,9						
55								97,0		95,9	96,0	92,9						
60								98,0										
DR(slope, a) (%/min)	2,42	2,33	2,24	1,65	2,08	1,66	2,35	2,28	2,16	1,93	1,92	1,83	2,16	2,33	2,20	2,49	2,37	2,40
Constant, b				3,52	7,18	3,90	0,17	0,00	0,48	-1,37			0,32	0,47				
Drying time (100 %) (min)	41,7	43,6	45,5	58,6	44,7	57,9	42,5	43,8	46,1	52,5	53,1	55,5	46,4	42,9	45,2	40,7	42,7	42,2
Average drying time within TH (min)	43,6			53,7			44,2			53,7			44,8			41,9		
STD within TH	1,93			7,82			1,81			1,57			1,79			1,03		
CV% within TH	4,42			14,6			4,10			2,93			4,01			2,45		
Average drying time among TH (min)	47,0																	
STD among TH	5,31																	
CV% among TH	11,3																	



**Table C.7 — Method B drying test for sample 3**

Time(min): X	Testing house (TH): Data: Loss % in water mass Lt: (y)																	
	A			B			C			D			E			F		
0	0,0	0,0	0,0	0,0	0,0	0,0	0,0	0,0	0,0	0,0	0,0	0,0	0,0	0,0	0,0	0,0	0,0	0,0
5	15,0	14,9	18,6	17,3	26,0			18,8			13,0	14,0	17,6	21,8	17,5		18,0	
10	33,0	32,7	35,3	26,9	37,5			34,7			27,0	28,0	36,3	39,6	38,8		37,0	
15				36,5	50,0			51,5			40,0	41,0	53,9	60,4	59,2			
20	67,0	64,4	67,6	45,2	60,6			65,3			50,0	50,0	73,5	78,2	79,6		72,0	
25				54,8	71,2			81,2			62,0	62,0	84,3	91,1	91,3			
30	90,0	88,1	91,2	63,5	80,8			90,1			75,0	76,0	92,2	96,0	96,1		95,0	
35				71,2	87,5			94,1			86,0	86,0	95,1	97,0	98,1			
40		97,0		78,8	91,3			95,0			91,0	91,0					99,0	
45					96,2			96,0			95,0	94,0						
50								97,0			95,0	94,0						
55								97,0			96,0	97,0						
60								98,0										
DR(slope, a) (%/min)	3,38	2,99	3,36	1,89	2,38			3,21			2,45	2,44	3,47	3,90	4,02		3,61	
Constant, b		1,19	0,98	5,92				1,74			1,33	2,00	0,93	0,99			0,20	
Drying time (100 %) (min)	29,8	33,1	29,5	49,7	37,8			30,6			40,4	40,2	28,6	25,4	25,2		27,7	
Average drying time within TH (min)	30,8			43,9			32,9			40,5			26,4			28,0		
STD within TH	2,00			5,92			2,12			0,40			1,90			1,27		
CV% within TH	6,48			13,5			6,43			1,00			7,22			4,54		
Average drying time among TH (min)	33,7																	
STD among TH	7,01																	
CV% among TH	20,8																	

**Table C.8 — Method B drying test result for sample 4**

Time(min): X	Testing house (TH): Data: Loss % in water mass Lt: (y)																	
	A			B			C			D			E			F		
0	0,0	0,0	0,0	0,0	0,0	0,0	0,0	0,0	0,0	0,0	0,0	0,0	0,0	0,0	0,0	0,0	0,0	0,0
5	8,9	6,1	9,9	22,9	22,1	15,5	8,9	8,0	7,9	6,0	7,2	8,1	6,9	8,3		7,4		9,0
10	20,8	17,3	17,8	34,3	31,7	23,3	19,8	16,0	17,8	16,0	16,5	16,2	19,8	18,8	20,4	16,8		18,0
15				44,8	41,3	30,1	30,7	26,0	27,7	22,0	22,7	23,2	29,7	29,2	31,1			
20	40,6	35,7	39,6	55,2	51,9	38,8	41,6	35,0	36,6	29,0	28,9	30,3	38,6	38,5				38,0
25				65,7	62,5	46,6	52,5	44,0	45,5	37,0	37,1	39,4	48,5	49,0				
30	60,4	55,1	58,4	76,2	73,1	53,4	62,4	54,0	55,4	46,0	45,4	47,5	59,4	56,3	59,2	55,8		58,0
35				86,7	82,7	62,1	72,3	61,0	63,4	53,0	52,6	54,5	68,3	65,6	68,9			
40		73,5		94,3	92,3	69,9	79,2	71,0	70,3	59,0	58,8	61,6	76,2	75,0	77,7	74,7		

Table C.8 (continued)

Time(min): X	Testing house (TH): Data: Loss % in water mass Lt: (y)																	
	A			B			C			D			E			F		
45				98,1	77,7	85,1	78,0	78,2	66,0	64,9	66,7							
50							83,0	85,1	73,0	73,2	74,7							
55							90,0		80,0	79,4	80,8							
60							93,0											
DR(slope, a) (%/min)	2,03	1,87	1,96	2,33	2,23	1,64	1,97	1,73	1,74	1,47	1,44	1,48	1,96	1,89	1,92	1,90		1,94
Constant, b				7,46	6,65	4,89	0,88	0,14	0,99	0,22	0,82	1,24	0,53	0,07				0,64
Drying time (100 %) (min)	49,4	54,2	51,2	39,7	41,9	58,1	50,3	57,9	57,1	68,0	68,7	66,8	50,8	52,9	51,5	53,4		51,2
Average drying time within TH (min)	51,6			46,6			55,1			67,8			51,7			51,0		
STD within TH	2,42			10,0			4,18			0,95			1,06			2,42		
CV% within TH	4,69			21,5			7,58			1,41			2,06			4,75		
Average drying time among TH (min)	54,0																	
STD among TH	7,30																	
CV% among TH	13,5																	

C.3.3 Method A2 test

Four testing houses from Japan participated in this round robin test.

Test results for samples using Method A2 drying test are shown in [Table C.9](#), [Table C.10](#), and [Table C.11](#).

Table C.9 — Method A2 drying test result for sample 5

Time (min): X	Testing house (TH): Data: Loss % in water mass Lt: (y)														
	A			B			C			D					
0	0,0	0,0	0,0	0,0	0,0	0,0	0,0	0,0	0,0	0,0	0,0	0,0	0,0	0,0	0,0
5	15,0	6,5	13,6	15,0	12,7	17,9	16,0	13,8	15,9	16,0	14,8	13,8			
10	33,8	28,6	28,4	31,3	26,6	33,3	32,1	33,8	35,4	34,6	33,3	30,0			
15	47,5	42,9	42,0	43,8	48,1	47,4	48,1	48,8	52,4	51,9	49,4	47,5			
20	62,5	58,4	58,0	63,8	59,5	66,7	65,4	66,3	67,1	67,9	66,7	65,0			
25	77,5	74,0	70,4	77,5	67,1	76,9	80,2	81,3	81,7	82,7	81,5	80,0			
30	88,8	83,1	82,7	93,8	84,8	87,2	90,1	91,3	92,7	93,8	93,8	91,3			
35	95,0	90,9	92,5		94,9	94,9	97,5								
40															
45															
50															
55															
60															
DR(slope, a) (%/min)	2,97	2,90	2,79	3,12	2,83	2,95	3,23	3,31	3,31	3,35	3,31	3,26			

Table C.9 (continued)

Time (min): X	Testing house (TH): Data: Loss % in water mass Lt: (y)											
	A			B			C			D		
Constant, b	1,34	-2,43	0,27	-0,48	0,23	2,84	0,06	-0,71	0,70	0,22	-0,41	-1,43
Drying time (100 %) (min)	33,2	35,3	35,7	32,2	35,3	33,0	30,9	30,5	30,0	29,8	30,3	31,1
Average drying time within TH (min)	34,7			33,5			30,5			30,4		
STD within TH	1,37			1,60			0,47			0,65		
CV% within TH	3,93			4,77			1,53			2,14		
Average drying time among TH (min)	32,3											
STD among TH	2,18											
CV% among TH	6,8											

Table C.10 — Method A2 test result for sample 6

Time (min): X	Testing house (TH): Data: Loss % in water mass Lt: (y)											
	A			B			C			D		
0	0,0	0,0	0,0	0,0	0,0	0,0	0,0	0,0	0,0	0,0	0,0	0,0
5	15,0	16,3	18,8	18,8	18,8	19,0	17,5	19,0	19,8	16,7	23,2	17,7
10	35,0	35,0	37,5	41,3	41,3	41,8	40,0	43,0	43,2	42,3	43,9	41,8
15	55,0	63,8	57,5	62,5	62,5	60,8	61,3	65,8	64,2	64,1	67,1	64,6
20	72,5	76,3	75,0	80,0	80,0	79,7	80,0	87,3	81,5	83,3	85,4	84,8
25	85,0	90,0	86,3	92,5	93,8	92,4	91,3	94,9	93,8	97,4	96,3	96,2
30	93,8	96,3	95,0									
35												
40												
45												
50												
55												
60												
DR(slope, a) (%/min)	3,67	3,84	3,75	4,08	4,08	4,03	4,08	4,43	4,15	4,28	4,29	4,33
Constant, b			0,00	-0,25	-0,25	0,00	-1,00	-1,27	0,25	-1,54	0,98	-1,52
Drying time (100 %) (min)	27,6	26,5	26,7	24,6	24,6	24,8	24,8	22,9	24,0	23,7	23,1	23,5
Average drying time within TH (min)	26,9			24,7			23,9			23,4		
STD within TH	0,63			0,14			0,97			0,32		
CV% within TH	2,33			0,57			4,07			1,38		
Average drying time among TH (min)	24,7											
STD among TH	1,56											
CV% among TH	6,3											

Table C.11 — Method A2 drying test result for sample 7

Time (min): X	Testing house (TH): Data: Loss % in water mass <i>Lt</i> : (y)								
	A			B			C		
0	0,0	0,0	0,0	0,0	0,0	0,0	0,0	0,0	0,0
5	23,5	31,3	21,0	13,9	16,7	17,5	12,8	16,7	14,1
10	42,0	47,5	39,5	32,9	34,6	37,5	34,6	33,3	32,1
15	60,5	70,0	63,0	53,2	55,1	56,3	57,7	50,0	51,3
20	80,2	86,3	72,8	72,2	74,4	75,0	73,1	66,7	67,9
25	97,5		91,4	88,6	89,7	91,3	89,7	83,3	87,2
30				98,7	98,7		94,9	94,9	92,3
35									
40									
45									
50									
55									
60									
DR(slope, a) (%/min)	3,96	4,17	3,61	3,65	3,67	3,78	3,73	3,33	3,52
Constant, b	1,73	4,75	1,73	-2,11	-0,79	-0,50	-1,95	0,00	-1,95
Drying time (100 %) (min)	24,8	22,8	27,2	28,0	27,5	26,6	27,3	30,0	28,9
Average drying time within TH (min)	24,9			27,4			28,8		
STD within TH	2,19			0,70			1,34		
CV% within TH	8,78			2,55			4,65		
Average drying time among TH (min)	27,0								
STD among TH	1,93								
CV% among TH	7,1								

## Annex D (informative)

### An example of interpretation for test result

The textile fabrics which are considered to have the good drying property are specified from the long experience in Japan as shown in [Table D.1](#). The evaluation should be done for the textiles with a good water absorption property which is specified by [Annex A](#).

This is only one example. The required specification value should be selected by the concerned parties.

**Table D.1 — Example of application from test result for 100 % applied water drying**

Method	A1		A2		B	
Fibre material	Drying time for 100 % drying (min/100 %)		Drying time for 100 % drying (min/100 %)		Drying time for 100 % drying (min/100 %)	
	Woven	Knit	Woven	Knit	Woven	Knit
Synthetic fibres 100 %	≤70	≤75	≤30	≤35	≤40	≤45
Synthetic fibres/Cellulose fibres (50 %/50 % blend)	≤75	≤80	≤35	≤40	≤50	≤55
Cellulose fibres 100 %	≤80	≤85	≤40	≤45	≤60	≤65

NOTE 1 If required 90 % drying or other % drying, the standard values are calculated by proportion.

NOTE 2 If required blend ratio standard values for textiles, calculate by proportion as well.

## Bibliography

- [1] ISO 1130, *Textile fibres — Some methods of sampling for testing*
- [2] ISO 4787, *Laboratory glassware — Volumetric instruments — Methods for testing of capacity and for use*
- [3] ISO 105-E04, *Textiles — Tests for colour fastness — Part E04: Colour fastness to perspiration*
- [4] BS 4554:1970, *Methods of test for wettability of textile fabrics*



---

---

**ICS 59.080.01**

Price based on 24 pages