

INTERNATIONAL STANDARD

ISO 17567

First edition
2005-05-01

Agricultural and forestry tractors and implements — Hydraulic power beyond

*Tracteurs agricoles et forestiers et instruments — Puissance
hydraulique externe disponible*



Reference number
ISO 17567:2005(E)

© ISO 2005

PDF disclaimer

This PDF file may contain embedded typefaces. In accordance with Adobe's licensing policy, this file may be printed or viewed but shall not be edited unless the typefaces which are embedded are licensed to and installed on the computer performing the editing. In downloading this file, parties accept therein the responsibility of not infringing Adobe's licensing policy. The ISO Central Secretariat accepts no liability in this area.

Adobe is a trademark of Adobe Systems Incorporated.

Details of the software products used to create this PDF file can be found in the General Info relative to the file; the PDF-creation parameters were optimized for printing. Every care has been taken to ensure that the file is suitable for use by ISO member bodies. In the unlikely event that a problem relating to it is found, please inform the Central Secretariat at the address given below.

© ISO 2005

All rights reserved. Unless otherwise specified, no part of this publication may be reproduced or utilized in any form or by any means, electronic or mechanical, including photocopying and microfilm, without permission in writing from either ISO at the address below or ISO's member body in the country of the requester.

ISO copyright office
Case postale 56 • CH-1211 Geneva 20
Tel. + 41 22 749 01 11
Fax + 41 22 749 09 47
E-mail copyright@iso.org
Web www.iso.org

Published in Switzerland

Foreword

ISO (the International Organization for Standardization) is a worldwide federation of national standards bodies (ISO member bodies). The work of preparing International Standards is normally carried out through ISO technical committees. Each member body interested in a subject for which a technical committee has been established has the right to be represented on that committee. International organizations, governmental and non-governmental, in liaison with ISO, also take part in the work. ISO collaborates closely with the International Electrotechnical Commission (IEC) on all matters of electrotechnical standardization.

International Standards are drafted in accordance with the rules given in the ISO/IEC Directives, Part 2.

The main task of technical committees is to prepare International Standards. Draft International Standards adopted by the technical committees are circulated to the member bodies for voting. Publication as an International Standard requires approval by at least 75 % of the member bodies casting a vote.

Attention is drawn to the possibility that some of the elements of this document may be the subject of patent rights. ISO shall not be held responsible for identifying any or all such patent rights.

ISO 17567 was prepared by Technical Committee ISO/TC 23, *Tractors and machinery for agriculture and forestry*, Subcommittee SC 4, *Tractors*.

Introduction

The implements and mounted equipment attached to agricultural and forestry tractors requiring the hydraulic power and control offered by the tractor's hydraulic system have greatly increased in number, complexity and need for efficient operation in recent years. As a result, many such implements include specialized valves and require the capability to easily connect, interface and control the tractor's implement hydraulic system.

ISO 17567 sets forth the interfaces necessary to effectively and properly accomplish the connection of the various tractor and implement combinations.

www.iso.org

Agricultural and forestry tractors and implements — Hydraulic power beyond

1 Scope

This International Standard specifies the hydraulic power beyond of tractors used in agriculture and forestry, and the number, type, capacity and identification of the associated connections between these tractors and their implements.

2 Normative references

The following referenced documents are indispensable for the application of this document. For dated references, only the edition cited applies. For undated references, the latest edition of the referenced document (including any amendments) applies.

ISO 789-10, *Agricultural tractors — Test procedures — Part 10: Hydraulic power at tractor/implement interface*

ISO 5675:1992, *Agricultural tractors and machinery — General purpose quick-action hydraulic couplers*

ISO 5598, *Fluid power systems and components — Vocabulary*

ISO 10448:1994, *Agricultural tractors — Hydraulic pressure for implements*

ISO 16028:1999, *Hydraulic fluid power — Flush-face type, quick-action couplings for use at pressures of 20 MPa (200 bar) to 31,5 MPa (315 bar) — Specifications*

3 Terms and definitions

For the purposes of this document the following definitions apply.

3.1

hydraulic power beyond

agricultural or forestry tractor's hydraulic power and/or control features, available to implements independent of the tractor's remote valves

3.2

pressure port

connection used to provide access to a tractor's main source of hydraulic power

3.3

return port

connection for the return flow from an implement or attached equipment

3.4

load signal (pressure) port

connection used to provide access to a tractor's control signal network

3.5 drain port
connection used to provide access to a tractor's lowest pressure return port for flows such as motor internal leakage

3.6 hydraulic power beyond kit
kit provided by agricultural and forestry tractor manufacturers that includes all brackets, fittings, seals, lines, quick couplings, dust protection, instructions for installation [including flow class reference, load signal (pressure) drop values, and return pressure] on the tractor, and instructions for connection of implements to the hydraulic power beyond ports

4 Systems and interfaces (see Figures 1 to 4)

4.1 Open-centre hydraulic system

On agricultural and forestry tractor systems with open-centre hydraulic valves as defined in ISO 5598, pressure, return and drain ports are required. The schematic of Figure 1 shows two basic means for providing hydraulic power beyond interfaces (power beyond priority or tractor valve priority) for a typical hydraulic motor connected to a tractor with an open-centre hydraulic system.

4.2 Constant-pressure closed-centre hydraulic system

On agricultural and forestry tractor systems with closed-centre hydraulic valves as defined in ISO 5598, pressure, return and drain ports are required. The schematic of Figure 2 shows one basic means for providing a hydraulic power beyond interface for a typical hydraulic motor connected to a tractor with a constant-pressure closed-centre hydraulic system.

4.3 Load-sensing closed-centre hydraulic system

On agricultural and forestry tractor systems with load-sensing hydraulic valves, pressure, return, load signal (pressure) and drain ports are required. The schematic of Figure 3 shows one basic means for providing a hydraulic power beyond interface for a typical hydraulic motor connected to a tractor with a load-sensing hydraulic system.

The signal from the implement connected to the load signal (pressure) port must be resolved with the load signal from the tractor's valves before being sent to the pump. This resolution valving or circuitry shall be provided by the tractor manufacturer. The implement manufacturer shall ensure that the implement's load signal is vented when all external functions are in their hold position.

4.4 Load-sensing closed-centre hydraulic system with fixed displacement pump

The schematic of Figure 4 shows one basic means for providing a hydraulic power beyond interface for a typical hydraulic motor connected to a tractor with a load-sensing closed-centre hydraulic system.

The signal from the implement connected to the load signal (pressure) port must be resolved with the load signal from the tractor's valves before being sent to the pump. This resolution valving or circuitry shall be provided by the tractor manufacturer. The implement manufacturer shall ensure that the implement's load signal is vented when all external functions are in their hold position.

5 Flow classes

Hydraulic power beyond flow classes as specified for a single connection shall be in accordance with Table 1.

Table 1 — Flow classes

Class	Flow L/min ^{a, b}
1	Up to 45
2	45 to 100
3	Above 100
^a Pressure port flow available can vary with system type and tractor system function.	
^b At rated engine speed.	

6 Hydraulic power beyond

6.1 General

The tractor manufacturer should provide one or more sets of hydraulic power beyond ports.

The tractor manufacturer shall specify the maximum hydraulic power beyond flow class and system type for each set of hydraulic power beyond ports. Pressure and temperature characteristics shall be in accordance with ISO 10448:1994, Table 1. Drain port back pressure shall not exceed

- 100 kPa, gauge, at 20 L/min, and
- 25 kPa, gauge, at zero flow conditions.

When quick-action couplings are used, female halves conforming to ISO 16028 (non-preferred — ISO 7241 or ISO 5675), shall be mounted on the tractor in order to create a uniform system interface between different manufacturers and system types.

NOTE If reference is made to ISO 7241, size 19 can be considered as corresponding to size 20.

The preferred sizes of hydraulic power beyond quick-action couplings in accordance with ISO 16028 are given in Table 2.

Table 2 — Quick-action couplings

Hydraulic power beyond Flow class ^a	Preferred quick-action coupling size ^b			
	Pressure	Return	Load signal	Drain
1	12,5	12,5	6,3	Size 10
2		19		
3		25		
^a The declared quick-action coupling class usage may be varied to suit or enhance the power beyond application.				
^b Usage of non-preferred quick-action couplings should conform in size to this table, but system performance characteristics will vary.				

ISO 17567:2005(E)

The quick-action pressure coupling shall have a self-sealing capability but shall not have *connect-while-engine-is-running* capability. The quick-action return, load signal (pressure) and drain couplings may have *connect-under-pressure* capability, but shall have the flow path open after connection. All quick-action couplers should have a breakaway functionality as defined in ISO 5598.

The maximum pressure drop from the supply port of the tractor to the load signal of the work port of the implement control valve shall be considered when designing power beyond circuits. The tractor manufacturer should state the load signal (pressure) pressure drop available at rated flow between the power beyond pressure and load signal (pressure) quick-action couplings.

The tractor manufacturer shall provide information as part of the hydraulic power beyond kit for connection of hydraulic power beyond circuits; while the implement manufacturer shall provide instructions for connection of the implement to the tractor system types for which it is designed.

6.2 Port and quick-action coupling identification

The ports on the tractor and the quick-action couplings that are installed as part of the hydraulic power beyond kit should be identified using the following alphabetical symbols.

Pressure port:	P
Return port:	R
Load signal (pressure) port:	LS
Drain port:	D

7 Testing hydraulic power beyond systems capabilities

Flow and power from hydraulic power beyond pressure ports should be measured according to ISO 789-10, with

- the engine running at rated speed, and
- the return port pressure measured both with and without quick-action couplings.

Drain port pressure should be measured according to ISO 789-10, both with and without quick-action couplings.

For flow, see 6.1.

Load signal (pressure) pressure drop available should be measured as the maximum pressure differential achievable across a throttle valve mounted close to the pressure port at rated flow.

NOTE For the testing of load-sensing closed-centre hydraulic systems, see Figure 5.

8 Location of connections

The connections may be located according to ISO 5675.

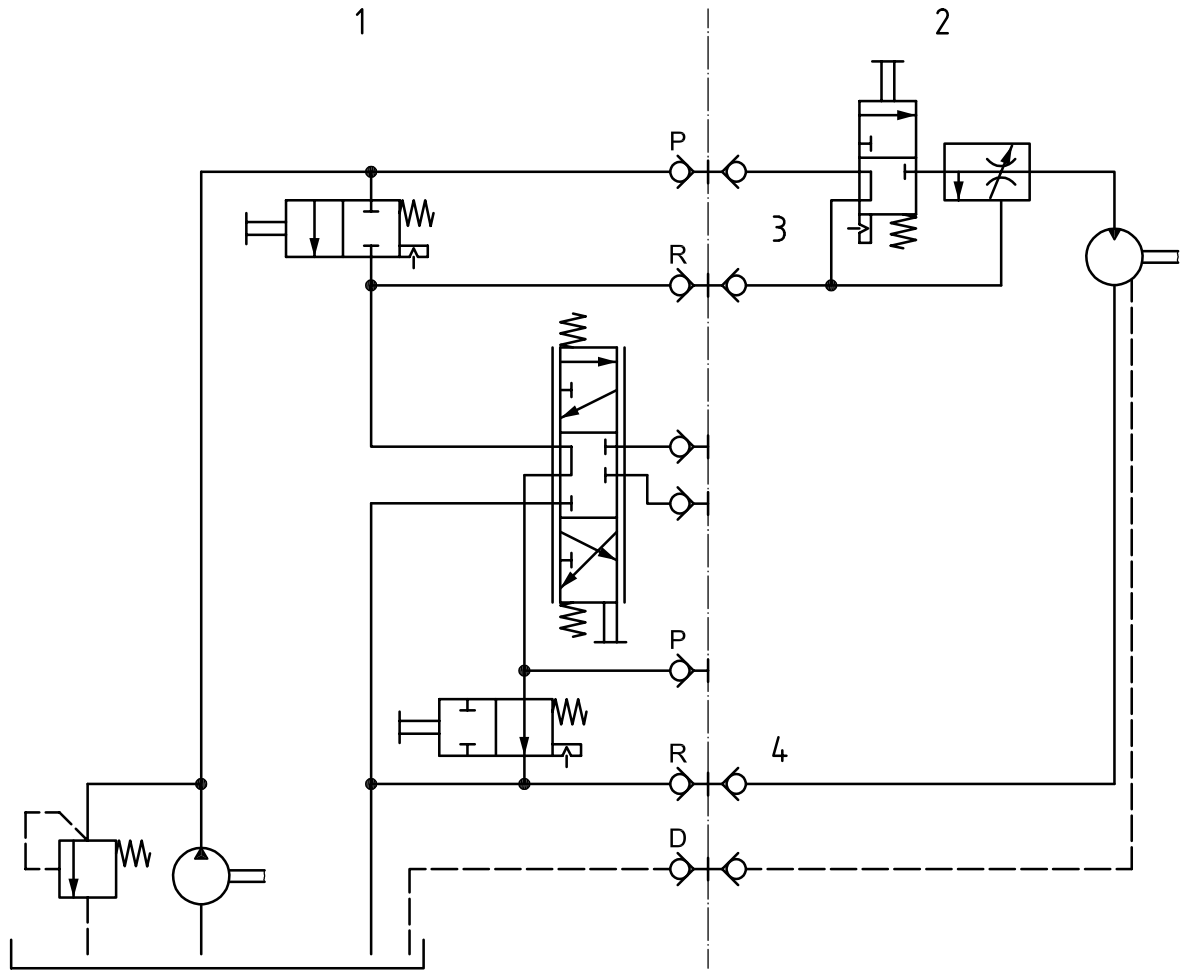

Key

- 1 tractor circuit
- 2 implement circuit
- 3 tractor valve priority
- 4 power beyond priority

Figure 1 — Open-centre hydraulic system

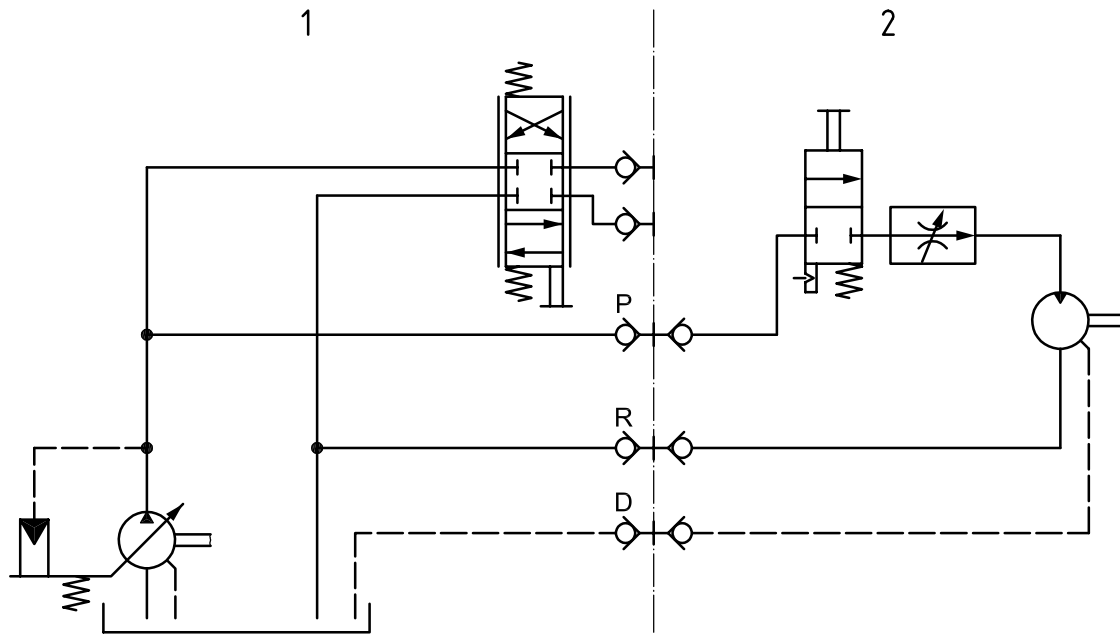

- Key**
 1 tractor circuit
 2 implement circuit

Figure 2 — Constant-pressure closed-centre hydraulic system

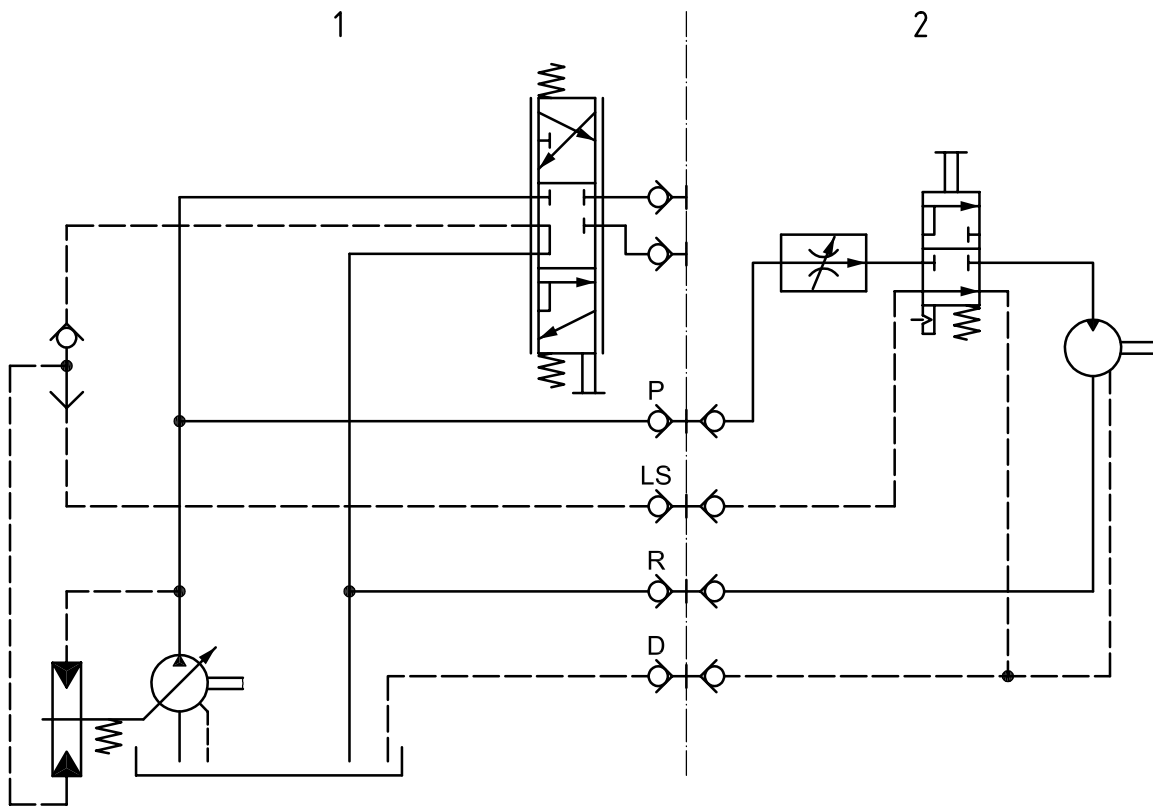

- Key**
 1 tractor circuit
 2 implement circuit

Figure 3 — Load-sensing closed-centre hydraulic system

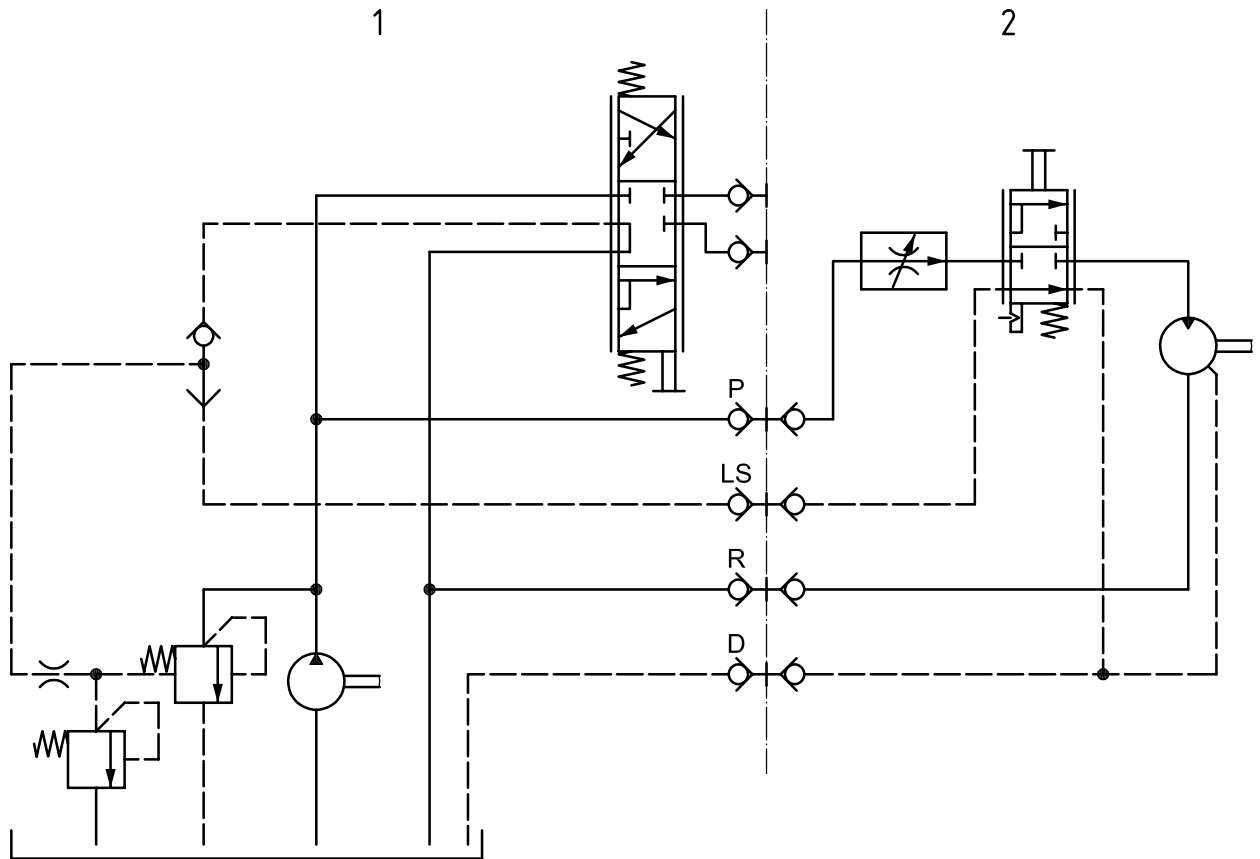

Key

- 1 tractor circuit
- 2 implement circuit

Figure 4 — Load-sensing closed-centre hydraulic system with fixed displacement pump

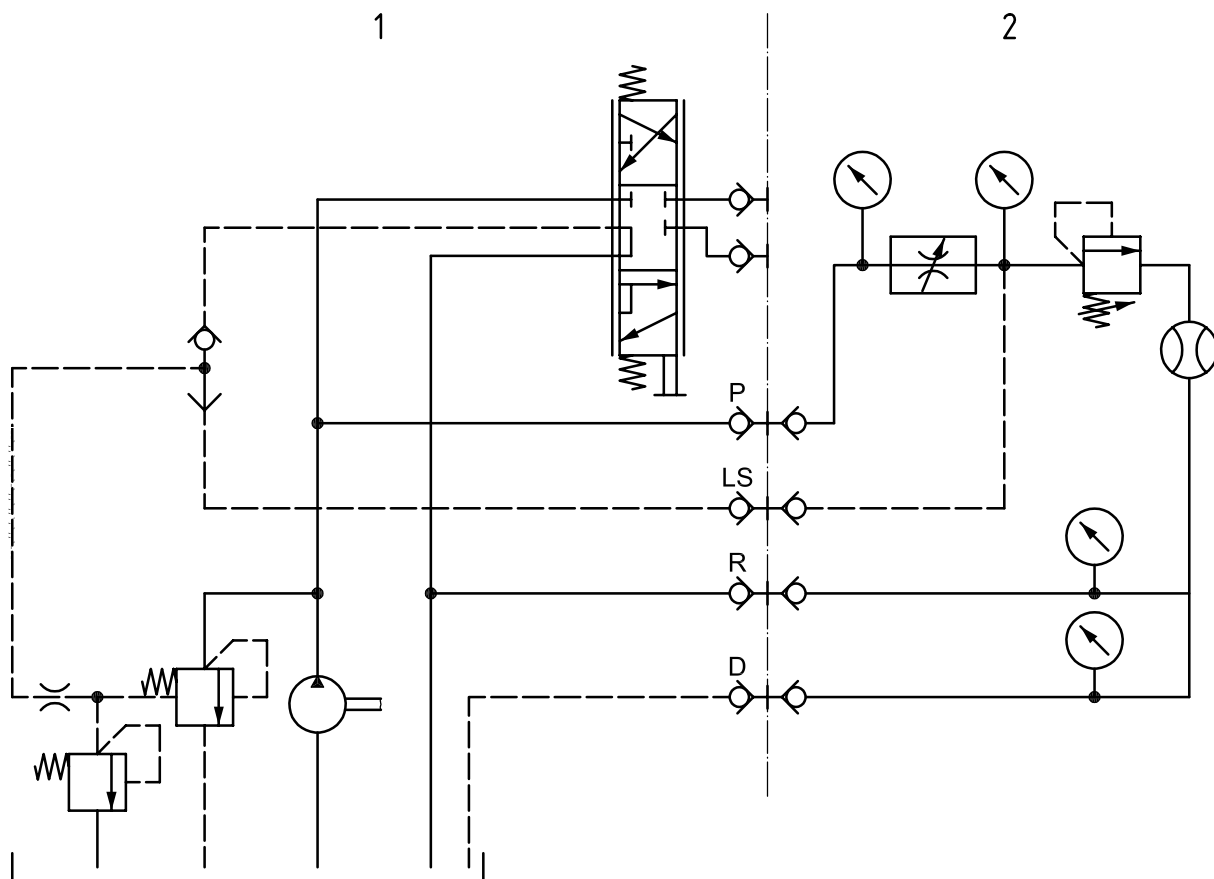

Key

- 1 tractor circuit
- 2 test circuit

Figure 5 — Load-sensing closed-centre hydraulic system — Power beyond test circuit

Bibliography

- [1] ISO 1219-1:1991, *Fluid power systems and components — Graphic symbols and circuits diagrams — Part 1: Graphic symbols*
- [2] ISO 7241-1:1987, *Hydraulic fluid power — Quick-action couplings — Part 1: Dimensions and requirements*

.....

ICS 65.060.10

Price based on 9 pages