

INTERNATIONAL
STANDARD

ISO
17509

First edition
2016-10-01

Dentistry — Torque transmitter for handpieces

Médecine bucco-dentaire — Transmetteur de couple pour pièces à main



Reference number
ISO 17509:2016(E)

© ISO 2016



COPYRIGHT PROTECTED DOCUMENT

© ISO 2016, Published in Switzerland

All rights reserved. Unless otherwise specified, no part of this publication may be reproduced or utilized otherwise in any form or by any means, electronic or mechanical, including photocopying, or posting on the internet or an intranet, without prior written permission. Permission can be requested from either ISO at the address below or ISO's member body in the country of the requester.

ISO copyright office
Ch. de Blandonnet 8 • CP 401
CH-1214 Vernier, Geneva, Switzerland
Tel. +41 22 749 01 11
Fax +41 22 749 09 47
copyright@iso.org
www.iso.org

Contents

Page

Foreword	iv
Introduction	v
1 Scope	1
2 Normative references	1
3 Terms and definitions	1
4 Classification	2
5 Intended performance	2
6 Performance attributes	2
6.1 Dimensions.....	2
6.2 Performance.....	2
6.3 Material selection.....	2
7 Performance evaluation	4
8 Manufacturing	4
9 Resistance to reprocessing	4
10 Information to be supplied by the manufacturer	4
11 Testing	4
11.1 Inspection of technical product file.....	4
11.2 Dimensions.....	4
11.3 Stall torque.....	5
11.3.1 Apparatus.....	5
11.3.2 Procedure.....	5

Foreword

ISO (the International Organization for Standardization) is a worldwide federation of national standards bodies (ISO member bodies). The work of preparing International Standards is normally carried out through ISO technical committees. Each member body interested in a subject for which a technical committee has been established has the right to be represented on that committee. International organizations, governmental and non-governmental, in liaison with ISO, also take part in the work. ISO collaborates closely with the International Electrotechnical Commission (IEC) on all matters of electrotechnical standardization.

The procedures used to develop this document and those intended for its further maintenance are described in the ISO/IEC Directives, Part 1. In particular the different approval criteria needed for the different types of ISO documents should be noted. This document was drafted in accordance with the editorial rules of the ISO/IEC Directives, Part 2 (see www.iso.org/directives).

Attention is drawn to the possibility that some of the elements of this document may be the subject of patent rights. ISO shall not be held responsible for identifying any or all such patent rights. Details of any patent rights identified during the development of the document will be in the Introduction and/or on the ISO list of patent declarations received (see www.iso.org/patents).

Any trade name used in this document is information given for the convenience of users and does not constitute an endorsement.

For an explanation on the meaning of ISO specific terms and expressions related to conformity assessment, as well as information about ISO's adherence to the World Trade Organization (WTO) principles in the Technical Barriers to Trade (TBT) see the following URL: www.iso.org/iso/foreword.html.

The committee responsible for this document is ISO/TC 106, *Dentistry*, Subcommittee SC 4, *Dental instruments*.

Introduction

Based on ISO 13504, this International Standard describes accessories that are inserted into dental handpieces and that impart rotational forces from a dental handpiece to dental implants or their connecting parts.

Dentistry — Torque transmitter for handpieces

1 Scope

This International Standard specifies requirements for torque transmitters to be used in oral implantology in conjunction with a dental handpiece as an accessory in the placement of dental implants and the further manipulation of connecting parts in the craniofacial area.

This International Standard applies to torque transmitters used for placement and for removal in the oral cavity of the patient which are connected to power-driven systems having torque control mechanism, but does not apply to the power-driven systems themselves.

This International Standard does not include the dental implant nor parts that would be connected to it.

With regard to safety, this International Standard gives requirements for classification, intended performance, performance attributes, material selection, performance evaluation, manufacture, reprocessing and information to be supplied by the manufacturer.

2 Normative references

The following documents, in whole or in part, are normatively referenced in this document and are indispensable for its application. For dated references, only the edition cited applies. For undated references, the latest edition of the referenced document (including any amendments) applies.

ISO 1942, *Dentistry — Vocabulary*

ISO 1797-1, *Dentistry — Shanks for rotary instruments — Part 1: Shanks made of metals*

ISO 3274, *Geometrical Product Specifications (GPS) — Surface texture: Profile method — Nominal characteristics of contact (stylus) instruments*

ISO 4288, *Geometrical Product Specifications (GPS) — Surface texture: Profile method — Rules and procedures for the assessment of surface texture*

ISO 6507-1, *Metallic materials — Vickers hardness test — Part 1: Test method*

ISO 10664, *Hexalobular internal driving feature for bolts and screws*

ISO 13504:2012, *Dentistry — General requirements for instruments and related accessories used in dental implant placement and treatment*

ISO 16443, *Dentistry — Vocabulary for dental implants systems and related procedure*

IEC 62366-1, *Medical devices — Part 1: Application of usability engineering to medical devices*

3 Terms and definitions

For the purposes of this document, the terms and definitions given in ISO 1942, ISO 13504, ISO 16443 and the following apply.

3.1

accessory used in dental implant placement and treatment

non-invasive surgical device used with a transient usage in direct or indirect contact to the human body to be used in the placement of dental implants and the further manipulation of connecting parts

3.2

torque transmitter

non-invasive surgical device designed to transmit a rotary movement from a dental handpiece to a dental implant or a dental implant connecting parts

4 Classification

Torque transmitters are classified according to ISO 13504:2012, 4.1 to 4.3 as given in [Table 1](#).

Table 1 — Classification of torque transmitter

ISO 13504, Subclause	Classification requirements	Selection	Description
4.1	Intended usage	Type 1	Energized or motor-driven instrument
4.2	Tissue contact	Class 3	Without tissue contact
4.3	Reprocessing	Group 1	Multiple use

5 Intended performance

ISO 13504:2012, Clause 5 a) and b) and IEC 62366-1 apply.

6 Performance attributes

ISO 13504:2012, Clause 6 applies.

6.1 Dimensions

The dimensions and tolerances of the shank shall be in accordance with ISO 1797-1, Type 1 shank and the shape and dimensions of the head is at the discretion of the manufacturer.

The surface roughness, as determined by the methods described in ISO 3274 and ISO 4288, shall be as specified in ISO 1797-1.

Test in accordance with [11.1](#).

6.2 Performance

Torque transmitters connected to an appropriate dental handpiece shall be designed to transmit a torque of at least 0,8 Nm for the insertion of dental implants.

Shape and dimensions of engaging part of applicable implant bodies or connecting parts shall be contained at least in the labelled information.

Test in accordance with [11.3](#).

NOTE The measure detail is a limiting value on technical data and not a medical statement.

The construction of torque transmitters shall provide for their safe and reliable operation in connection with dental handpieces in accordance with IEC 62366-1.

6.3 Material selection

ISO 13504:2012, Clause 7 applies.

The manufacturer of the torque transmitter shall use a material as specified in ISO 13504:2012, Annex A.

The hardness for shanks made from steel, as determined by the method specified in ISO 6507-1, shall be not less than 500 HV 5.

Dimensions in millimetres

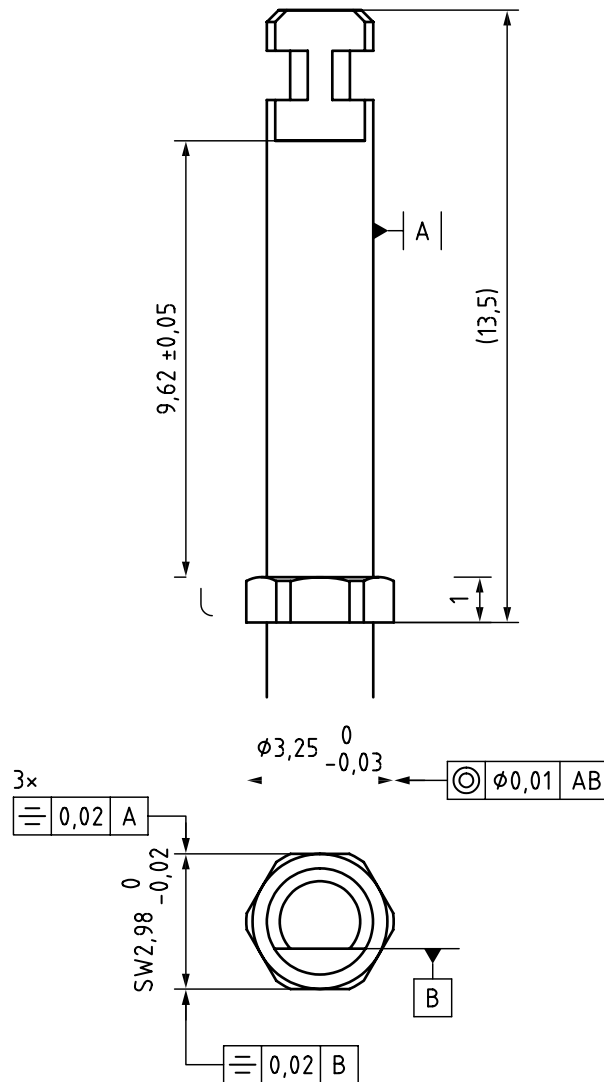

Figure 1 — Torque transmitter: Convex hexagonal

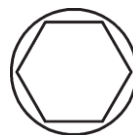

Figure 2 — Shapes of engaging part with implant bodies or connecting parts in torque transmitter: Concave-shaped



Figure 3 — Shapes of engaging part with implant bodies or connecting parts in torque transmitter: Square-shaped



Figure 4 — Shapes of engaging part with implant bodies or connecting parts in torque transmitter: Hexalobular-shaped (star-shaped)

7 Performance evaluation

ISO 13504:2012, Clause 8 applies.

8 Manufacturing

ISO 13504:2012, Clause 9 applies.

Torque transmitters shall be manufactured in accordance with the requirements specified in [Clauses 6](#) and [7](#).

Test in accordance with [11.1](#).

9 Resistance to reprocessing

ISO 13504:2012, Clause 10 applies.

All instruments intended for multiple use shall withstand 100 reprocessing cycles, as defined by the manufacturer's instructions, without deterioration in performance or showing signs of corrosion.

The reprocessing cycle shall include the recommended methods of cleaning, disinfection and sterilization.

10 Information to be supplied by the manufacturer

ISO 13504:2012, Clause 11 applies.

Shape and dimensions of engaging part of applicable implant bodies or connecting parts shall be contained at least in the labelled information.

Instruments and related accessories shall be marked with name or registered trademark of manufacturer, where appropriate.

11 Testing

11.1 Inspection of technical product file

Visually inspect the technical product file to determine compliance with the requirements.

11.2 Dimensions

Testing shall be carried out by visual inspection and measurement of all dimensions described by the manufacturer by using appropriate measuring instruments.

11.3 Stall torque

11.3.1 Apparatus

- a) **Chuck system**, in accordance with ISO 1797-1.
- b) **Torque watch or dynamometer**, capable of measuring the torque, in Newton metres, with an accuracy of $\pm 10\%$.

11.3.2 Procedure

Insert and fix the torque transmitter in the chuck system and connect the torque measuring device to the outer end of the torque transmitter. Rotate the torque; watch slowly until it reaches the maximum allowed torque. No sign of deformation shall be observed.

