

---

---

**Geometrical product specifications  
(GPS) — General concepts —**

Part 1:

**Model for geometrical specification and  
verification**

*Spécification géométrique des produits — Concepts généraux —*

*Partie 1: Modèle pour la spécification et la vérification géométriques*



Reference number  
ISO 17450-1:2011(E)

© ISO 2011



**COPYRIGHT PROTECTED DOCUMENT**

© ISO 2011

All rights reserved. Unless otherwise specified, no part of this publication may be reproduced or utilized in any form or by any means, electronic or mechanical, including photocopying and microfilm, without permission in writing from either ISO at the address below or ISO's member body in the country of the requester.

ISO copyright office  
Case postale 56 • CH-1211 Geneva 20  
Tel. + 41 22 749 01 11  
Fax + 41 22 749 09 47  
E-mail [copyright@iso.org](mailto:copyright@iso.org)  
Web [www.iso.org](http://www.iso.org)

Published in Switzerland

# Contents

Page

Foreword .....	iv
Introduction.....	v
<b>1 Scope .....</b>	<b>1</b>
<b>2 Normative references .....</b>	<b>1</b>
<b>3 Terms and definitions .....</b>	<b>1</b>
<b>4 Application and future prospects .....</b>	<b>11</b>
<b>5 General .....</b>	<b>11</b>
<b>6 Features .....</b>	<b>12</b>
<b>6.1 General .....</b>	<b>12</b>
<b>6.2 Ideal features .....</b>	<b>13</b>
<b>6.3 Non-ideal features .....</b>	<b>15</b>
<b>6.4 Relationships between geometrical feature terms .....</b>	<b>16</b>
<b>7 Characteristics .....</b>	<b>18</b>
<b>7.1 General .....</b>	<b>18</b>
<b>7.2 Intrinsic characteristics of ideal features .....</b>	<b>18</b>
<b>7.3 Situation characteristics between ideal features .....</b>	<b>19</b>
<b>7.4 Situation characteristics between non-ideal and ideal features .....</b>	<b>20</b>
<b>8 Operations .....</b>	<b>21</b>
<b>8.1 Feature operations .....</b>	<b>21</b>
<b>8.2 Evaluation .....</b>	<b>25</b>
<b>8.3 Transformation .....</b>	<b>26</b>
<b>9 Specification .....</b>	<b>26</b>
<b>9.1 General .....</b>	<b>26</b>
<b>9.2 Specification by dimension .....</b>	<b>26</b>
<b>9.3 Specification by zone .....</b>	<b>27</b>
<b>9.4 Deviation .....</b>	<b>27</b>
<b>10 Verification .....</b>	<b>28</b>
<b>Annex A (informative) Examples of applications to ISO 1101 .....</b>	<b>29</b>
<b>Annex B (informative) Mathematical symbols and definitions .....</b>	<b>43</b>
<b>Annex C (informative) Comparison between tolerancing and metrology .....</b>	<b>55</b>
<b>Annex D (informative) Concept diagram for characteristics .....</b>	<b>57</b>
<b>Annex E (informative) Invariance classes .....</b>	<b>58</b>
<b>Annex F (informative) Relationship to the GPS matrix model .....</b>	<b>60</b>
<b>Bibliography .....</b>	<b>62</b>
<b>Alphabetical index .....</b>	<b>63</b>

## Foreword

ISO (the International Organization for Standardization) is a worldwide federation of national standards bodies (ISO member bodies). The work of preparing International Standards is normally carried out through ISO technical committees. Each member body interested in a subject for which a technical committee has been established has the right to be represented on that committee. International organizations, governmental and non-governmental, in liaison with ISO, also take part in the work. ISO collaborates closely with the International Electrotechnical Commission (IEC) on all matters of electrotechnical standardization.

International Standards are drafted in accordance with the rules given in the ISO/IEC Directives, Part 2.

The main task of technical committees is to prepare International Standards. Draft International Standards adopted by the technical committees are circulated to the member bodies for voting. Publication as an International Standard requires approval by at least 75 % of the member bodies casting a vote.

Attention is drawn to the possibility that some of the elements of this document may be the subject of patent rights. ISO shall not be held responsible for identifying any or all such patent rights.

ISO 17450-1 was prepared by Technical Committee ISO/TC 213, *Dimensional and geometrical product specifications and verification*.

This first edition of ISO 17450-1 cancels and replaces ISO/TS 17450-1:2005, which has been technically revised. It also incorporates the Technical Corrigendum ISO/TS 17450-1:2005/Cor.1:2007.

ISO 17450 consists of the following parts, under the general title *Geometrical product specifications (GPS) — General concepts*:

- *Part 1: Model for geometrical specification and verification*
- *Part 2: Basic tenets, specifications, operators, uncertainties and ambiguities*

## Introduction

This part of ISO 17450 is a geometrical product specification (GPS) document and is to be regarded as a global GPS document (see ISO/TR 14638). It influences all chain links of the chains of standards.

The ISO/GPS Masterplan given in ISO/TR 14638 gives an overview of the ISO/GPS system of which this document is a part. The fundamental rules of ISO/GPS given in ISO 8015 apply to this document and the default decision rules given in ISO 14253-1 apply to specifications made in accordance with this document, unless otherwise indicated. For more detailed information on the relationship of this part of ISO 17450 to other standards and to the GPS matrix model, see Annex F.

In a market environment of increased globalization, the exchange of technical product information is of high importance and the need to express unambiguously the geometry of mechanical workpieces of vital urgency. Consequently, codification associated with the macro- and micro-geometry of workpiece specifications needs to be unambiguous and complete if the functional geometrical variation of parts is to be limited; in addition, the language ought to be applicable to CAx systems.

The aim of ISO/TC 213 is to provide the tools for a global and “top-down” approach to GPS. These tools form the basis of new standards specifying a common language for geometrical definition. This language can be used by design (assemblies and individual workpieces), manufacturing and inspection, to describe the measurement procedure, regardless of the media (e.g. a paper drawing, numerical drawing or exchange file) used. The tools are based on the characteristics of features, as well as on the constraints between the features and on feature operations, used for the creation of different geometrical features.

Vertical line of text on the right side of the page.

# Geometrical product specifications (GPS) — General concepts —

## Part 1: Model for geometrical specification and verification

### 1 Scope

This part of ISO 17450 provides a model for geometrical specification and verification and defines the corresponding concepts. It also explains the mathematical basis of the concepts associated with the model and defines general terms for geometrical features of workpieces.

This part of ISO 17450 defines the fundamental concepts for the GPS system in order to:

- provide nonambiguous GPS language to be used in design, manufacturing and verification,
- identify features, characteristics and rules to provide the basis for specifications,
- provide a complete symbology language to indicate GPS specifications,
- provide simplified symbology by defining default rules, and
- provide consistent rules for verification.

### 2 Normative references

The following referenced documents are indispensable for the application of this document. For dated references, only the edition cited applies. For undated references, the latest edition of the referenced document (including any amendments) applies.

ISO/IEC Guide 99, *International vocabulary of metrology — Basic and general concepts and associated terms (VIM)*

### 3 Terms and definitions

For the purposes of this document, the terms and definitions given in ISO/IEC Guide 99 and the following apply.

#### 3.1 real surface

(of a workpiece) set of features which physically exist and separate the entire workpiece from the surrounding medium

## 3.2

### surface model

model representing the set of physical limits of the virtual or the real workpiece

NOTE 1 This model applies to all closed surfaces.

NOTE 2 The surface model allows the definition of single features, sets of features, and/or portions of features. The total product is modelled by a set of surface models corresponding to each workpiece.

### 3.2.1

#### nominal model

(of a workpiece) model of the perfect shape defined by the designer

NOTE The nominal model represents the design intent.

### 3.2.2

#### non-ideal surface model

#### skin model

(of a workpiece) model of the physical interface of the workpiece with its environment

NOTE See Clause 5.

## 3.3

### geometrical feature

point, line, surface, volume or a set of these items

NOTE 1 The non-ideal surface model is a particular type of geometrical feature, corresponding to the infinite set of points defining the interface between the workpiece and its surroundings.

NOTE 2 A geometrical feature can be an ideal feature or a non-ideal feature, and can be considered as either a single feature or a compound feature.

### 3.3.1

#### ideal feature

feature defined by a parametrized equation

NOTE 1 The expression of the parametrized equation depends on the type of ideal feature and on its intrinsic characteristics.

NOTE 2 By default, an ideal feature is infinite. To change its nature, it is appropriate to specify this by adding the term "restricted" as in "restricted ideal feature".

#### 3.3.1.1

##### attribute of an ideal feature

property intrinsically attached to an ideal element

NOTE 1 Four levels of attributes can be defined for an ideal feature: 1) shape; 2) dimensional parameters from which a size can be defined in the case of dimensional feature; 3) situation feature; and 4) skeleton (when the size is set equal to zero).

NOTE 2 If the ideal feature is a feature of size, then one of parameters of the shape can be considered as a size.

##### 3.3.1.1.1

##### dimensional parameter

linear or angular dimension of an ideal feature used in the expression of its parametrized equation

NOTE A dimensional parameter can correspond to a size of a feature of size.

##### 3.3.1.1.2

##### skeleton feature

geometrical feature resulting from the reduction of a feature of size when its size is set equal to zero



NOTE 1 In the nominal model, the skeleton feature is a geometrical attribute of a nominal integral feature. A nominal integral feature and its skeleton belong to the same invariance class and have the same situation feature.

NOTE 2 In the non-ideal feature, several possible skeleton features exist for the same integral feature.

EXAMPLE In case of a torus, there are two dimensional parameters, one of which is a size (the small diameter of the torus). Its skeleton is a circle; its situation features are a plane (containing the circle) and a point (centre of the circle).

**3.3.1.1.3 situation feature**

point, straight line, plane or helix, from which the location and/or orientation of a geometrical feature can be defined

See Figures 1 to 4.

NOTE 1 A situation feature is a geometrical attribute of an ideal feature.

NOTE 2 No dimensional parameters are linked to a situation feature.

NOTE 3 In many cases, instead of using the situation helix, the axis of a situation helix is used.

EXAMPLE In the case of a torus, there are two dimensional parameters, one of which is a size (the small diameter of the torus). Its skeleton is a circle and its situation features are a plane (containing the circle) and a point (centre of the circle).

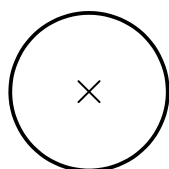

a) Situation point for a sphere

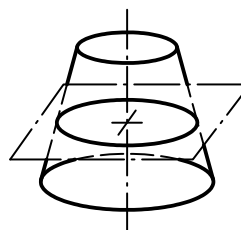

b) Situation point for a cone

Figure 1 — Example of situation points

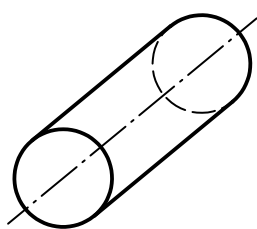

a) Situation straight line for a cylinder

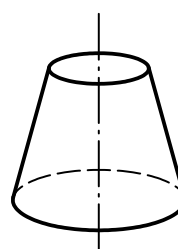

b) Situation straight line for a cone

Figure 2 — Example of situation straight lines

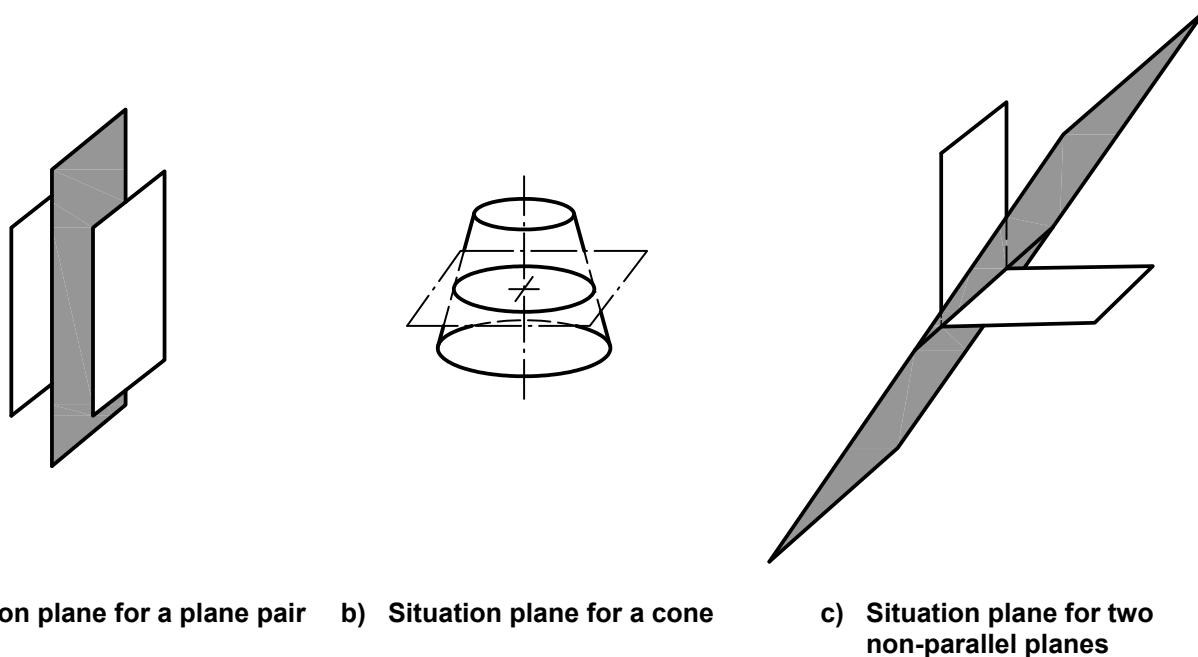

Figure 3 — Examples of situation planes

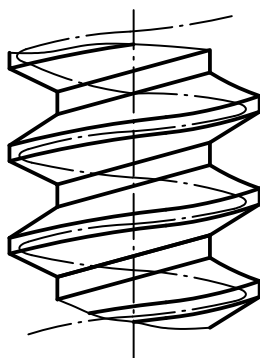

Figure 4 — Example of a situation helix

#### 3.3.1.1.4

##### shape

⟨of an ideal feature⟩ mathematical generic description defining the ideal geometry of a feature

NOTE An ideal feature of preset shape can be qualified or named.

EXAMPLE 1 Planar shape, cylindrical shape, spherical shape, conical shape.

EXAMPLE 2 A surface can be qualified as a “plane surface” or be directly named “plane”.

#### 3.3.1.2

##### invariance class

group of ideal features defined by the same displacement(s) of the ideal feature for which the feature is kept identical in the space

NOTE See Annex E.

**3.3.1.3****type**

⟨of an ideal feature⟩ name given for a set of shapes of an ideal feature

NOTE 1 See Tables 2 and 5.

NOTE 2 From a type of an ideal feature, a particular feature can be defined by giving value(s) to intrinsic characteristic(s).

NOTE 3 The type defines the parametrized equation of the ideal feature.

**3.3.1.4****nature**

⟨of an ideal feature⟩ property of an ideal feature to be a point, a line, a surface, or a volume or a set of these items

EXAMPLE The nature of a cylinder is a surface. The content of a sphere is a volume.

**3.3.1.5****feature of size**

feature of linear size or feature of angular size

**3.3.1.5.1****feature of linear size**

feature of size with linear size

geometrical feature, having one or more intrinsic characteristics, only one of which may be considered as a variable parameter, that additionally is a member of a “one parameter family”, and obeys the monotonic containment property for that parameter

See Figure 5.

NOTE 1 A feature of size can be a sphere, a circle, two straight lines, two parallel opposite planes, a cylinder, a torus, etc. In former standards, wedges and cones were considered as features of size, and torus size was not mentioned.

NOTE 2 There are restrictions when there are more than one intrinsic characteristic (e.g. torus).

NOTE 3 A feature of size is particularly useful for the expression of material requirements, i.e. least material requirement (LMR) and maximum material requirement (MMR).

NOTE 4 In Figure 5, the diameter of the sphere is an example of a size of a feature of linear size; the geometrical feature used to establish the feature of size is its skeleton feature. In the case of the sphere, the skeleton feature is a point.

EXAMPLE 1 A single cylindrical hole or shaft is a feature of linear size. Its linear size is its diameter.

EXAMPLE 2 A compound feature consisting of two single parallel planes such as a groove or a key is a feature of linear size. Its linear size is its width.

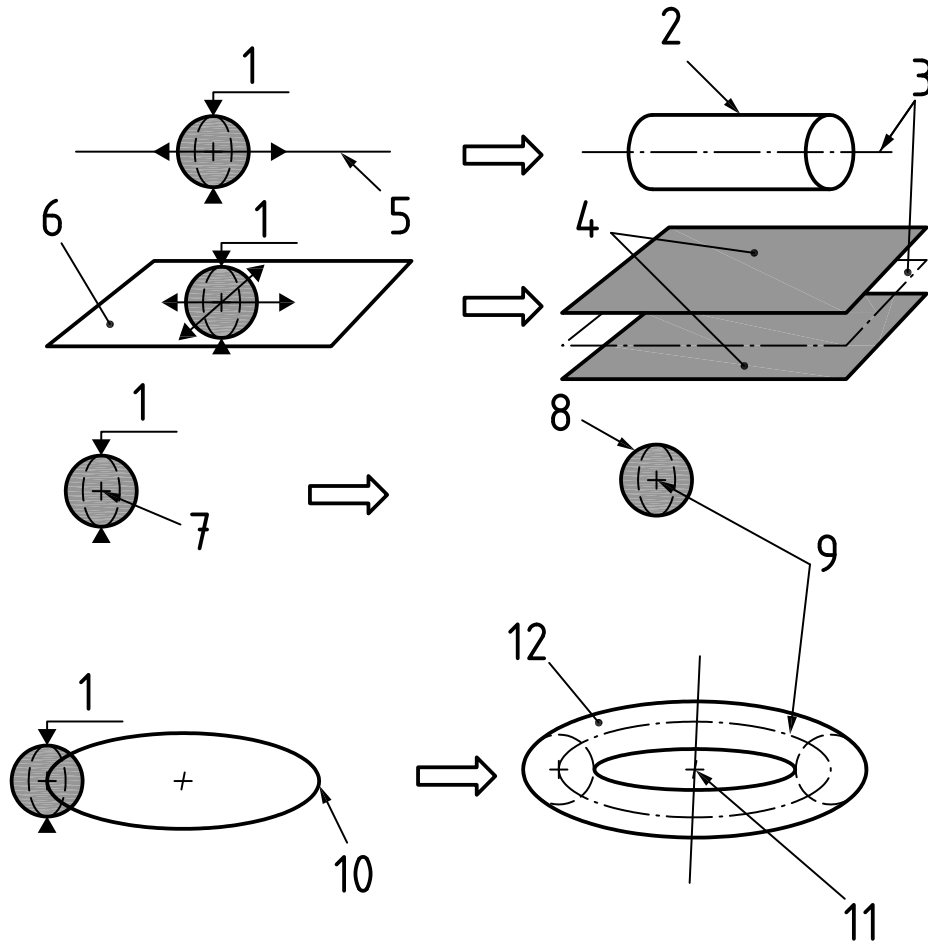

**Key**

- 1 size
- 2 cylinder
- 3 median feature
- 4 two opposite planes
- 5 skeleton: a straight line
- 6 skeleton: a plane
- 7 skeleton: a point
- 8 sphere
- 9 median feature
- 10 skeleton: a circle
- 11 situation feature
- 12 torus

**Figure 5 — Relation between the feature of size, the skeleton feature and the size**

**3.3.1.5.2 feature of angular size**

geometrical feature belonging to the revolutive invariance class whose genetrix is inclined nominally with an angle not equal to 0° or 90° or belonging to the prismatic invariance class and composed by two surfaces of same shape the angle between the two situation features

NOTE A cone and a wedge are features of angular size.

**3.3.2****non-ideal feature**

imperfect geometrical feature fully dependent on the non-ideal surface model or on the real surface of the workpiece

NOTE A non-ideal feature is by default of finite dimension.

**3.3.3****nominal feature**

ideal feature defined in the technical product documentation by the product designer

NOTE 1 A nominal feature is defined by the technical product documentation.

NOTE 2 A nominal feature can be finite or infinite; by default, it is finite.

EXAMPLE A perfect cylinder, defined in a drawing, is a nominal feature obeying a specific mathematical formula, for which dimensional parameters are associated, and which are defined in a reference mark related to the situation feature. The situation feature of a cylinder is a line which is commonly called "its axis". Taking this line as an axis of a Cartesian reference mark results in the formula  $x^2 + y^2 = D/2$ , with  $D$  being a dimensional parameter. A cylinder is a dimensional feature, whose size is its diameter  $D$ .

**3.3.4****real feature**

geometrical feature corresponding to a part of the workpiece real surface

**3.3.5****integral feature**

geometrical feature belonging to the real surface of the workpiece or to a surface model

NOTE 1 An integral feature is intrinsically defined, e.g. skin of the workpiece.

NOTE 2 For a statement of specifications, geometrical features obtained from partition of the surface model or of real surface of workpiece shall be defined. These features, called "integral features", are models of the different physical parts of the workpiece that have specific functions, especially those in contact with adjacent workpieces.

NOTE 3 An integral feature can be identified, for example, by

- a partition of the surface model,
- a partition of another integral feature, or
- a collection of other integral features.

**3.3.6****derived feature**

geometrical feature, which does not exist physically on the real surface of the workpiece and which is not natively a nominal integral feature

NOTE 1 A derived feature can be established from a nominal feature, an associated feature, or an extracted feature. It is qualified respectively as a nominal derived feature, an associated derived feature, or an extracted derived feature.

NOTE 2 The centre point, the median line and the median surface defined from one or more integral features are types of derived features.

EXAMPLE 1 The centre of the sphere is a derived feature obtained from a sphere, which is itself an integral feature.

EXAMPLE 2 The median line of the cylinder is a derived feature obtained from the cylindrical surface, which is an integral feature. The axis of a nominal cylinder is a nominal derived feature (skeleton of the cylinder).

EXAMPLE 3 A geometrical feature, obtained from an integral feature by shifting of a specific amount in the normal direction outside of material, is an other type of derived feature.

**3.3.7**

**extracted feature**

geometrical feature defining a set of finite number of points

NOTE 1 When the representativeness is defined by an infinite number of points, the word “extracted” is not associated with the considered terms.

NOTE 2 The concept “extracted” can apply to an integral feature or to a derived feature.

NOTE 3 An integral feature is by default an infinite representative, whereas an integral feature is extracted with a finite representative and performed in accordance with specified conventions.

**3.3.8**

**associated feature**

ideal feature established from a non-ideal surface model or from a real feature through an association operation

NOTE An associated feature can be established from an derived feature (extracted, filtered), or an integral feature (real, extracted, filtered).

**3.3.9**

**filtered feature**

non-ideal feature which is the result of a filtration of a non-ideal feature

See Figure 6.

NOTE 1 Non-ideal filtered features exist. Nominal filtered features or associated filtered features do not exist.

NOTE 2 With regards to the function, the features considered are often not directly integral features, but integral features after a filtration.

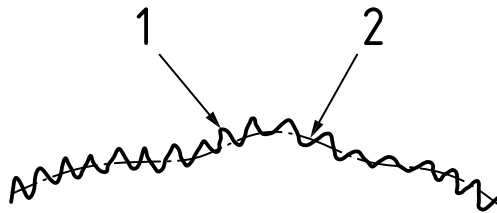

**Key**

- 1 non-ideal feature before filtration
- 2 filtered feature (non-ideal feature after filtration)

**Figure 6 — Specification and verification filtered features**

**3.3.10**

**reconstructed feature**

continuous geometrical feature defining a set of finite number of points

NOTE 1 When the representativeness is defined by an infinite number of points, the word “extracted” is not associated with the considered term.

NOTE 2 The concept “extracted” can apply to an integral feature or a derived feature.

NOTE 3 An integral feature is by default an infinite representative, whereas an integral feature is extracted with a finite representative and performed in accordance with specified conventions.

**3.4****operation**

specific tool required to obtain features or values of characteristics, their nominal value and their limit(s)

**3.4.1****feature operation**

specific tool required for obtaining features

**3.4.1.1****partition**

feature operation used to identify a portion of a geometrical feature belonging to the real surface of the workpiece or to a surface model of the workpiece

NOTE See 8.1.2.

**3.4.1.2****extraction**

feature operation used to identify specific points from a non-ideal feature

NOTE 1 To avoid aliasing, filtration is, mathematically, an integral part of extraction.

NOTE 2 See 8.1.3.

**3.4.1.3****filtration**

feature operation used to create a non-ideal feature from a non-ideal feature or to transform one variation curve to another by reducing the level of information

NOTE See 8.1.4.

**3.4.1.4****association**

feature operation used to fit ideal feature(s) to non-ideal feature(s) according to a criterion

NOTE See 8.1.5.

**3.4.1.5****collection**

feature operation used to identify more than one geometrical feature which together play a functional role

NOTE See 8.1.6.

**3.4.1.6****construction**

feature operation used to build ideal feature(s) from other ideal features within constraints

NOTE See 8.1.7.

**3.4.1.7****reconstruction**

feature operation used to create a continuous feature from an extracted feature

NOTE See 8.1.8.

**3.4.1.8****reduction**

feature operation used to establish a derived feature by calculation

EXAMPLE When a centre of a geometrical feature is defined as the barycenter of an extracted integral feature, the centre is obtained by reduction.

**3.4.2  
evaluation**

operation used to identify either the value of a characteristic or its nominal value and its limit(s)

NOTE See 8.2.

**3.4.3  
transformation**

operation used to convert one variation curve to another

NOTE See 8.3.

**3.5  
characteristic**

single property defined from one or more geometrical feature(s)

NOTE 1 A characteristic is expressed in linear or angular units or without a unit.

NOTE 2 See Annex D.

**3.5.1  
intrinsic characteristic**

characteristic of an ideal feature

NOTE 1 See 7.2.

NOTE 2 The intrinsic characteristics are the parameters of the parameterized equation of the ideal feature.

NOTE 3 The size of a feature of size is an intrinsic characteristic.

**3.5.2  
situation characteristic**

characteristic defining the relative location or orientation between two features

**3.5.2.1  
situation characteristic between ideal features**

characteristic defining the relative location or orientation between two ideal features

**3.5.2.2  
situation characteristic between non-ideal and ideal features**

characteristic defining the relative location between a non-ideal feature and an ideal feature

**3.6  
specification**

expression of permissible limits on a characteristic

**3.6.1  
specification by dimension**

specification that limits the permissible value of an intrinsic characteristic or of a situation characteristic between ideal features

**3.6.2  
specification by zone**

specification that limits the permissible variation of a non-ideal feature inside a space limited by an ideal feature or by ideal features

**3.7  
variation**

phenomenon whereby the value of a characteristic is not constant within one geometrical feature taken from one workpiece or within a set of workpieces



**3.7.1****variation curve**

characteristic variation represented in a coordinate system

NOTE 1 A variation curve can be obtained without transformation or by mathematical transformation. It can be qualified as direct or transformed.

NOTE 2 A variation curve can be filtered.

**3.8****deviation**

difference between the value of a characteristic obtained from the real surface of the workpiece or the non-ideal surface model and the corresponding nominal value

**4 Application and future prospects**

The surface models proposed in this part of ISO 17450 are aimed at

- a) expressing the fundamental concepts on which the geometrical specification of workpieces can be based, with a global approach including all the geometrical tools (e.g. operations) needed in GPS, and
- b) providing a mathematization of the concepts (see Annex B), in order to facilitate standardization inputs to
  - software designers for CAD-systems,
  - software designers for computing algorithms in metrology, and
  - standards makers on STEP (computerized exchange of product data between CAD-systems).

NOTE Others surface models are presented in ISO 22432, and are derived from the non-ideal surface model.

**5 General**

The geometrical specification is the design step where the field of permissible deviations of a set of characteristics of a workpiece is stated, accommodating the required functional performance of the workpiece (functional need). It defines a level of quality in conformance with manufacturing processes, the limits permissible for manufacturing, and the definition of the conformity of the workpiece (see Figure 7).



**Figure 7 — Relationship between functional needs and geometrical specification**

The designer first specifies a “workpiece” with a perfect form, i.e. with the shape and dimensions necessary to meet the functional requirements. This workpiece is called the “nominal model” (see Figure 8).

This first step establishes a representation of the workpiece with only nominal values that is impossible to produce or inspect (each manufacturing or measuring process has its own variability or uncertainty).

The real surface of the workpiece, which is the physical interface of the workpiece with its environment, has an imperfect geometry; it is impossible to completely capture the dimensional variation of the real surface of the workpiece in order to completely understand the extent of all variation.

From the nominal geometry, the designer imagines a model of this real surface, which represents the variations that could be expected on the real surface of the workpiece. This model representing the imperfect geometry of the workpiece is called the “non-ideal surface model” (see Figure 9).

The non-ideal surface model is used to simulate variations of the surface at a conceptual level. On this model, the designer will be able to optimize the maximum permissible limit values for which the function is downgraded but still ensured. These maximum permissible limit values define the tolerances of each characteristic of the workpiece.

NOTE This part of ISO 17450 does not include a methodology to evaluate how close the geometrical specification is to the functional specifications.

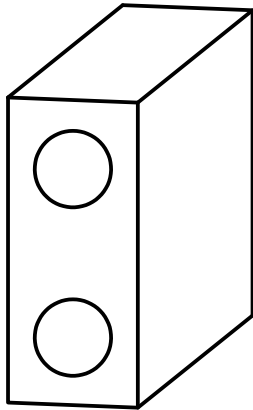

Figure 8 — Nominal model

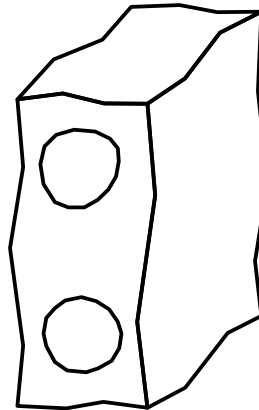

Figure 9 — Non-ideal surface model

Verification is the provision of objective evidence that the workpiece fulfils the specification.

The definition of the geometrical deviation is used to adjust the manufacturing process.

The metrologist begins by reading the specification, taking into account the non-ideal surface model, in order to know the specified characteristics. From the real surface of the workpiece, the metrologist defines the individual steps of the verification plan, depending on the measuring equipment.

Conformance is then determined by comparing the specified characteristics with the result of measurement (see Figure 10).



Figure 10 — Relationship between geometrical specification and result of measurement

## 6 Features

### 6.1 General

According to the definition of a geometrical feature, its nature is a point, line, surface or volume.

Two kinds of geometrical features can be distinguished:

- a) ideal features (see 6.2);
- b) non-ideal features (see 6.3).

## 6.2 Ideal features

**6.2.1** Ideal features are defined by type and by intrinsic characteristics.

An ideal feature is generally referred to by its type, for example, straight line, plane, cylinder, cone, sphere or torus.

Characteristics are discussed in Clause 7. An example of an intrinsic characteristic is the diameter of a cylinder.

**6.2.2** Ideal features used to define the nominal model are called “nominal features”. These are independent of the non-ideal surface model.

Ideal features, the characteristics of which are dependent on the non-ideal surface model, are called “associated features”.

For instance, the nominal model shown in Figure 11 is built with several ideal features of two types (plane and cylinder). The locations and orientations between the features are given by situation characteristics, and the diameters of the cylinders are given by intrinsic characteristics (see Clause 7).

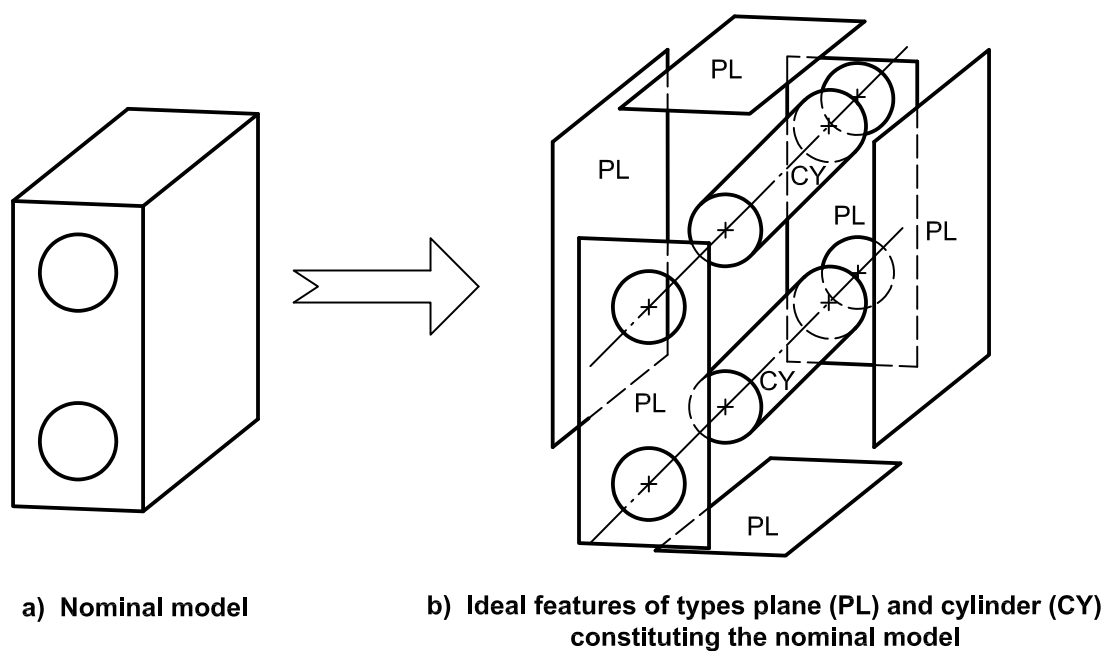

**Figure 11 — Building the nominal model**

**6.2.3** Ideal features can have an infinite extent or a finite extent:

- nominal features have a finite extent;
- associated features have by default an infinite extent else they are qualified with restricted (restricted associated feature).

**6.2.4** All ideal features belong to one of the seven invariance classes defined in Table 1.

**Table 1 — Invariance classes**

Invariance class	Unconstrained degrees of freedom
complex	none
prismatic	1 translation along a straight line
revolute	1 rotation around a straight line
helical	1 translation along and 1 rotation combined around a straight line
cylindrical	1 translation along and 1 rotation around a straight line
planar	1 rotation around a straight line and 2 translations in a plane perpendicular to the straight line
spherical	3 rotations around a point

**EXAMPLE 1** A cylinder is invariant either by translation along its axis or by rotation around its axis; it belongs to the cylindrical invariance class.

**EXAMPLE 2** A cone is invariant by rotation around its axis; it belongs to the revolute invariance class.

**EXAMPLE 3** A prism with elliptical section is invariant by a translation along a straight line; it belongs to the prismatic invariance class.

**6.2.5** For each ideal feature, one or more situation features can be defined, depending on its invariance class (see Annex E). A situation feature is a point, straight line, plane, or helix from which the location or orientation of a feature can be defined with characteristics.

Examples of situation features are given in Table 2.

**Table 2 — Examples of situation features of ideal features**

Invariance class	Type	Examples of situation features
complex	elliptic curve	ellipse plane, symmetry planes
	hyperbolic paraboloid	symmetry planes, tangent point
	...	...
prismatic	prism with an elliptic basis	symmetry planes, axis
	...	
revolute	circle	the plane containing the circle, the circle centre
	cone	the symmetry axis, apex
	torus	the plane perpendicular to the torus axis, the torus centre
	...	...
helical	helical line	helix
	helical surface with a basis of involute to a circle	helix
	...	...
cylindrical	straight line	the straight line <sup>a</sup>
	cylinder	the symmetry axis <sup>a</sup>
planar	plane	the plane
spherical	point	the point <sup>a</sup>
	sphere	the centre <sup>a</sup>

<sup>a</sup> No alternative situation feature can be chosen, because the result would be a different invariance class for the considered feature.

### 6.3 Non-ideal features

Non-ideal features are fully dependent on the non-ideal surface model. They can be

- the non-ideal surface model itself (see Figure 9),
- part of the non-ideal surface model (features called “partition features”) (see Figure 17),
- the derived partition features [features not included in the non-ideal surface model but created through an operation (see Clause 8) from part of the non-ideal surface model] (see Figure 12), or
- the intersection between the non-ideal surface model and an ideal feature.

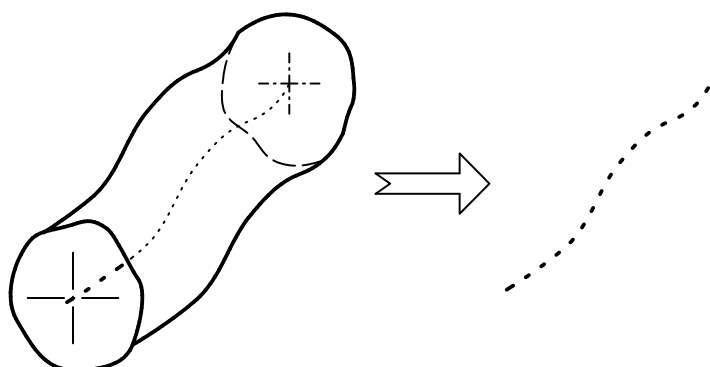
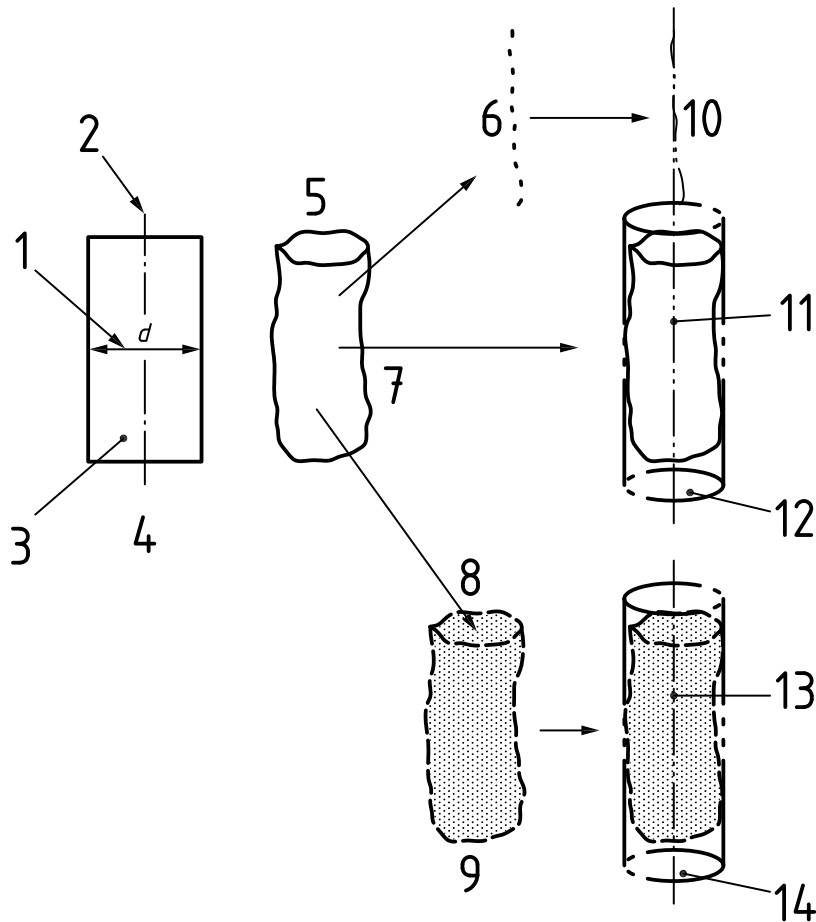

**Figure 12 — Derived partition feature**

Non-ideal features are bound and are composed of an infinite or finite set of points.

6.4 Relationships between geometrical feature terms

The relationship between geometrical feature definitions (illustrated in Figure 13) shows the possible complexity when the real workpiece or the non-ideal surface model – not the nominal model – is considered. The objective of GPS specifications is to define with the least ambiguity possible the intended characteristic to be evaluated either from one geometrical feature or between geometrical features, by specifying the characteristic and the geometrical feature from the real workpiece or its non-ideal surface model.



Key

- |   |   |    |  |
|---|---|----|--|
| 1 | size of the feature of size   | 8  | extraction                                 |
| 2 | nominal median feature  | 9  | non-ideal integral extracted surface       |
| 3 | nominal integral surface  | 10 | indirectly associated median feature       |
| 4 | nominal model of the surface  | 11 | directly associated median feature         |
| 5 | non-ideal model of the surface representing the real surface of the workpiece | 12 | ideal directly associated integral surface |
| 6 | non-ideal median feature  | 13 | directly associated median feature         |
| 7 | non-ideal integral surface  | 14 | ideal directly associated integral surface |

Figure 13 — Relationships between geometrical features

The relationships between attributes related to geometrical features are illustrated in Figure 14 and Tables 3 and 4.

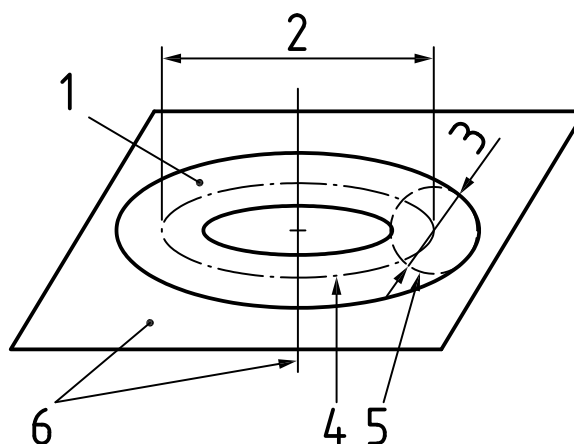

**Key**

- 1 integral nominal surface: a torus
- 2 size of the torus
- 3 other dimensional parameter of the torus
- 4 skeleton
- 5 generatrix of the torus
- 6 situation feature of the torus (straight line and perpendicular plan, or straight line and particular point of the straight line – this point corresponds to the intersection of a plan and a line)

**Figure 14 — Relationships between definitions of attributes of an ideal feature**

**Table 3 — Feature attributes of an ideal feature**

Geometrical definition of the feature relating to the feature form			Attribute of an ideal feature	
			Dimensional feature	Non-dimensional feature
Dimensional parameters	Yes	Size		No possible association
		Other?		
	No			
Situation feature		Point		
		Line		
		Plane		
		Helix		
Feature skeleton				
Composition of the feature		Simple		
		Compound		
		Pair		

Table 4 — Type of geometrical features and associated qualifiers

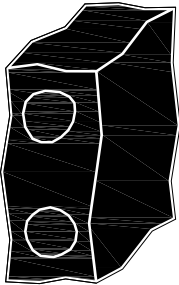
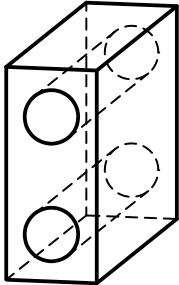
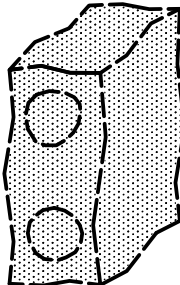
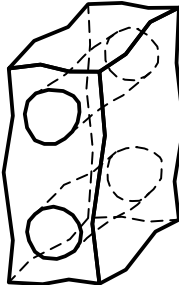
Taken from	Real surface of the workpiece	Surface model		
		Nominal model	Non-ideal surface model	
Illustration				
Integral feature	Real feature	Nominal integral feature	Example: extracted integral feature	Associated integral feature
Derived feature		Nominal derived feature	Example: extracted derived feature	Associated derived feature
Qualifier	Real	nominal	Examples: extracted; filtered; reconstructed	Associated
Type of geometrical feature	Non-ideal	Ideal	Non-ideal	Ideal

## 7 Characteristics

### 7.1 General

Characteristics are defined either

- on ideal features and called “intrinsic characteristics” (see 7.2 and B.3.1),
- between ideal features and called “situation characteristics” (see 7.3 and B.3.2), or
- between non-ideal and ideal features and also called “situation characteristics” (see 7.4 and B.3.3).

### 7.2 Intrinsic characteristics of ideal features

The intrinsic characteristics of an ideal feature are specific to the type of the feature itself. Examples of intrinsic characteristics are given in Table 5.



Table 5 — Examples of intrinsic characteristics of ideal features

Invariance class	Type	Examples of intrinsic characteristics
complex	elliptic curve polar surface ...	length of major and minor axes relative location of poles ...
prismatic	prism with an elliptic basis prism with a basis of involute to a circle ...	length of major and minor axes pressure angle, basis radius ...
revolute	circle cone torus ...	diameter apex angle generatrix and directrix diameters ...
helical	helical line helical surface with a basis of involute to a circle ...	helix pitch and radius helix angle, pressure angle, basis radius ...
cylindrical	straight line cylinder	none diameter
planar	plane	none
spherical	point sphere	none diameter

### 7.3 Situation characteristics between ideal features

A situation characteristic defines the relative situation (in terms of location or orientation) between two ideal situation features. The characteristics concerned are length and angle.

Situation characteristics can be separated into location characteristics and orientation characteristics (see Table 6).

Table 6 — Situation characteristics

Location	Orientation
point-point distance	straight line-straight line angle
point-straight line distance	straight line-plane angle
point-plane distance	plane-plane angle
straight line-straight line distance	
straight line-plane distance	
plane-plane distance	

EXAMPLE 1 The relative location between a sphere and a plane is given by the point-plane distance between the situation feature of the sphere (centre of the sphere) and the situation feature of the plane (the plane itself).

EXAMPLE 2 The relative orientation between a cylinder and a plane is given by the straight line-plane angle between the situation feature of the cylinder (axis of the cylinder) and the situation feature of the plane (the plane itself).

In some cases (e.g. asymmetric tolerancing), it is necessary to identify part of the space, for instance, to identify on which side of a symmetry plane is the largest part of the tolerance zone. The corresponding situation characteristics are called "signed characteristics" (see Figure 15). Signed characteristics can be: a point-plane distance; a straight line-straight line (non-parallel) distance; a straight line-plane distance; a plane-plane distance; a straight line-straight line angle; a straight line-plane angle; a plane-plane angle.

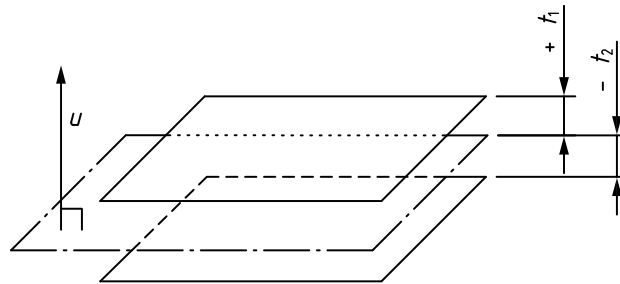

- Key**
- $u$  unit vector
  - $t_1$  signed characteristic 1
  - $t_2$  signed characteristic 2

Figure 15 — Signed characteristics

These signed characteristics are defined by vectors, depending on the orientation of the plane and straight line (see B.1 for the mathematical definition).

**7.4 Situation characteristics between non-ideal and ideal features**

Situation characteristics are also used to define the situation between non-ideal and ideal features.

These situation characteristics are only distances and are defined as functions of the distance between each point of the non-ideal feature and the ideal feature (see example in Figure 16). The functions are, for instance, the maximum, the minimum, or the sum of the squares of the distance of each point to the ideal feature. The situation characteristics will be used for operations of association.

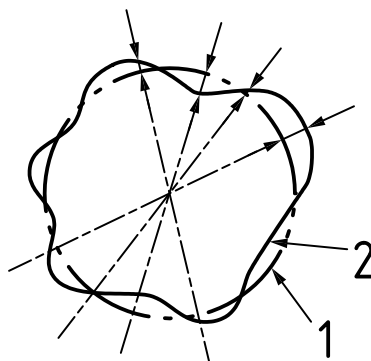

- Key**
- 1 ideal feature (circle)
  - 2 non-ideal feature ("circle" with form errors)

Figure 16 — Situation characteristics between non-ideal and ideal features

## 8 Operations

### 8.1 Feature operations

#### 8.1.1 General

Specific operations are required if ideal or non-ideal features are to be obtained. These operations can be used in any order. They are described in 8.1.2 to 8.1.8.

#### 8.1.2 Partition

A feature operation called “partition” is used to identify a portion of a geometrical feature.

It is used to obtain, from the non-ideal surface model or real surface, the non-ideal features corresponding to the nominal features (see Figure 17). It is also used to obtain limited parts of ideal features (e.g. a segment of a straight line) or non-ideal features (e.g. a section of a non-ideal surface).

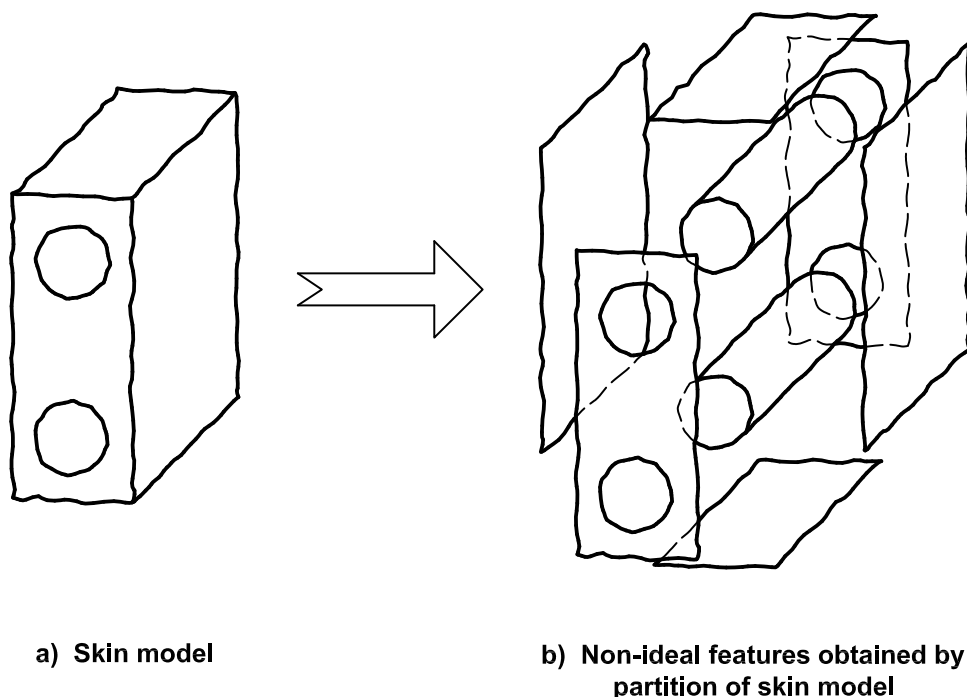
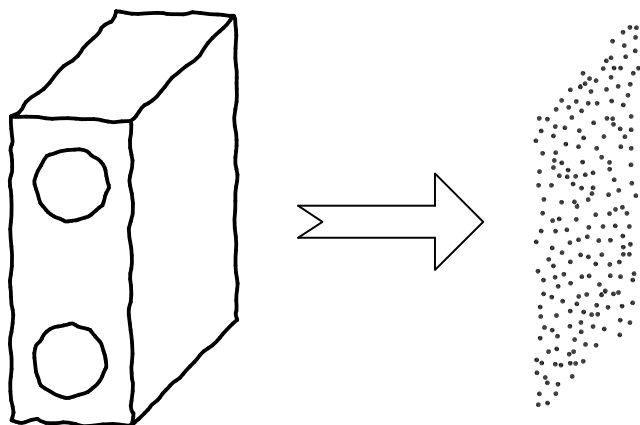

**Figure 17 — Partition of a non-ideal surface model**

For each non-ideal feature, there is a corresponding ideal feature (e.g. ideal plane and ideal cylinder) of the nominal model (compare Figures 11 and 17). The non-ideal features are obtained from the non-ideal surface model, in accordance with specified criteria.

#### 8.1.3 Extraction

A feature operation called “extraction” is used to identify a finite number of points from a non-ideal feature, in accordance with specified criteria (see Figure 18).



a) Skin model

b) Extracted points from a feature of the skin model

Figure 18 — Extracted points from a feature of the non-ideal surface model

#### 8.1.4 Filtration

A feature operation called “filtration” is used to distinguish between roughness, waviness, structure and form etc. (see Figure 19).

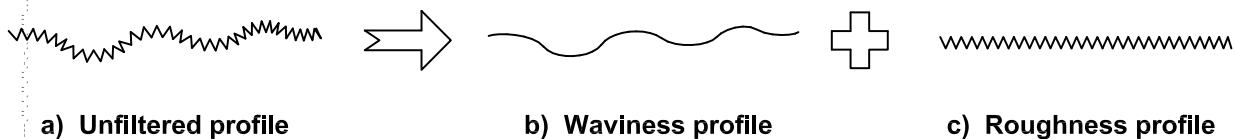

a) Unfiltered profile

b) Waviness profile

c) Roughness profile

Figure 19 — Example of separation of a profile

This operation permits the obtaining, from a non-ideal feature, of the feature that represents the considered characteristics.

This operation is done in accordance with specified criteria.

### 8.1.5 Association

A feature operation called “association” is used to fit ideal features to non-ideal features in accordance with specified criteria (see Figure 20).

The criteria of association give an objective for a characteristic and can set constraints. The constraints fix the value of the characteristics or set limits to the characteristic.

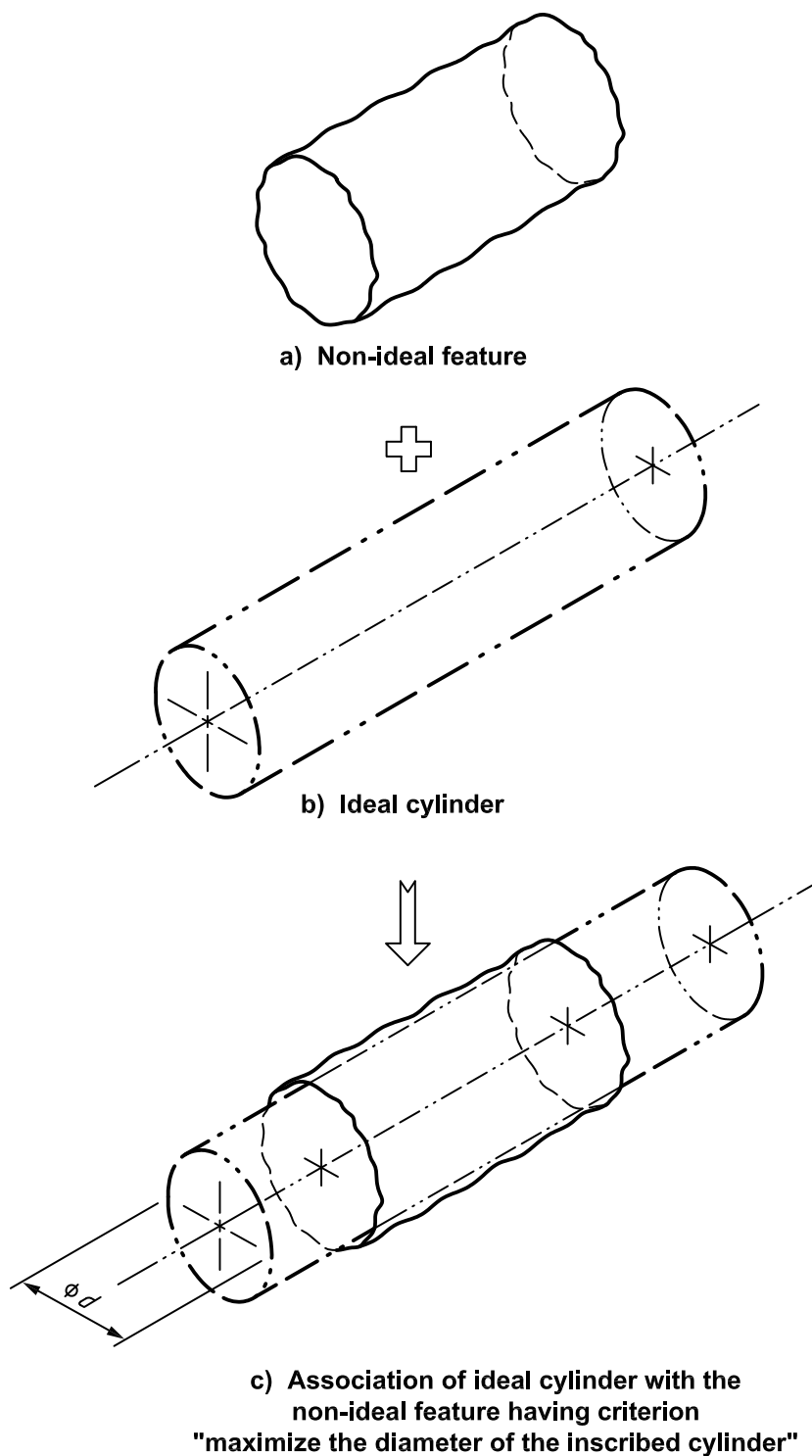

Figure 20 — Example of association

Constraints can apply to intrinsic characteristics, situation characteristics between ideal features, or situation characteristics between ideal and non-ideal features.

An ideal feature is associated to the non-ideal feature; for example, in the case of a cylinder, the association criteria could be

- minimize the sum of the squares of the distance between each point of the non-ideal feature to the ideal cylinder, or
- maximize the diameter of the inscribed cylinder (see Figure 20), or
- minimize the diameter of circumscribed cylinder, or
- other criteria.

**8.1.6 Collection**

A feature operation called “collection” is used to identify and consider some features together which together play a functional role (see Figure 21). It is possible to build the collection of ideal features or the collection of non-ideal features. All ideal features built with two collection operations fall within one of the seven invariance classes of Table 1.

The effect of the collection operation can change the type and the degree of invariance of the collection feature compared to the simple features composing the collection.

NOTE 1 A single feature is a continuous feature for which there does not exist any subset of the same dimensionality (point, line or surface) with an invariance degree greater than the invariance degree of the considered feature. For example, a cylinder is a single feature, while a collection surface consisting of two parallel cylinders is not, because a single cylinder has a greater invariance degree.

NOTE 2 A situation characteristic between two features becomes an intrinsic characteristic of the feature obtained by collection.

NOTE 3 Features considered in a collection feature need not be in contact.

In Figure 21, two parallel cylinders (whose axes lie in a plane and are parallel) are considered together (e.g. for building a common datum). The feature collection of the two cylinders is to be defined. This collection of two cylinders is only invariant by translation along a straight line. It belongs to the prismatic invariance class.

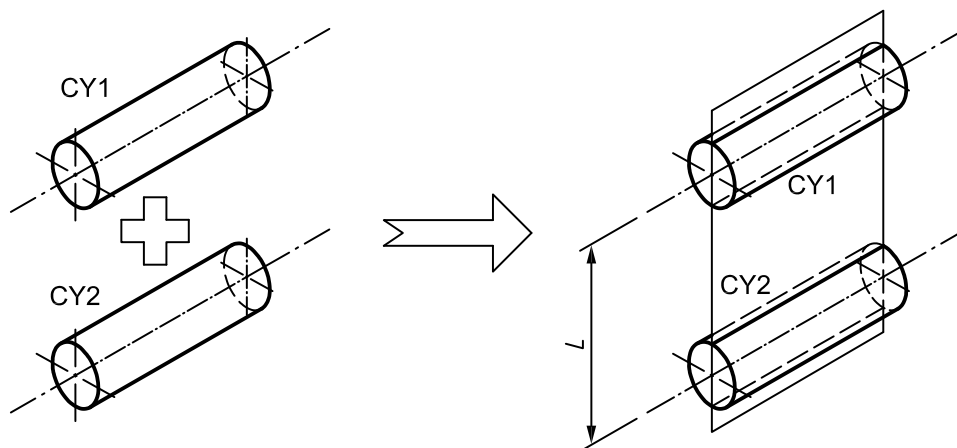

**Key**  
 CY1 ideal cylinder 1  
 CY2 ideal cylinder 2

**Figure 21 — Example of collection of two ideal cylinders**

### 8.1.7 Construction

A feature operation called “construction” is used to build ideal features from other features (see Figure 22). This operation shall respect constraints.

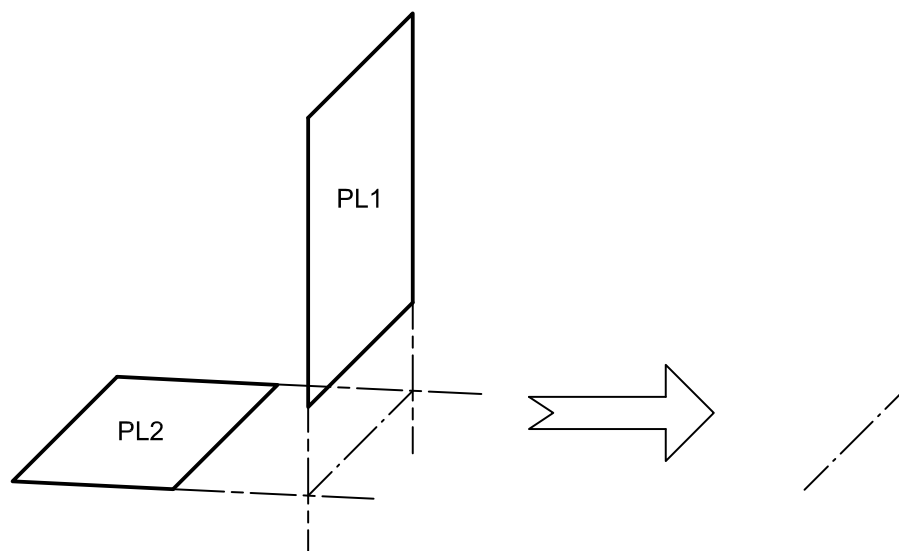

#### Key

- PL1 ideal plane 1
- PL2 ideal plane 2

**Figure 22 — Example of construction of a straight line by the intersection of two planes**

### 8.1.8 Reconstruction

A feature operation called “reconstruction” is used to create a continuous feature (close or not) from a non-continuous feature (e.g. extracted feature) (see Figure 23).

There are several types of reconstructions. Without this type of operation, it is not possible to define an intersection between an extracted feature and an ideal feature (this intersection could result in the empty set of points).

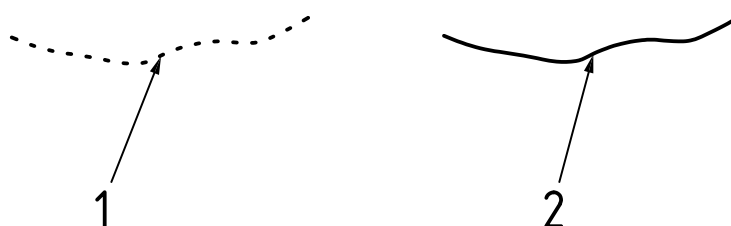

#### Key

- 1 extracted feature (non-continuous feature)
- 2 reconstructed feature (continuous feature)

**Figure 23 — Example of reconstruction**

## 8.2 Evaluation

An operation called “evaluation” is used to identify either the value of a characteristic or its nominal value and its limit or limits. The evaluation is always used after the feature operation or operations defining one specification or verification.

### 8.3 Transformation

When the basic characteristic is a local characteristic, a variation can be observed along the considered geometrical feature. This variation can be represented by a variation curve. This variation curve can be submitted to some treatments, these operations are called “transformations”.

EXAMPLE The determination of a ration curve is a transformation of a variation curve.

## 9 Specification

### 9.1 General

A specification consists in expressing the field of permissible deviations of a characteristic of a workpiece as permissible limits.

There are two ways to specify the permissible limits: by dimension (see 9.2) and by zone (see 9.3).

### 9.2 Specification by dimension

A specification by dimension limits the permissible value of an intrinsic characteristic (Table 5) or of a situation characteristic between ideal features (Table 6).

For instance, a specification by dimension can limit

- the diameter of a cylinder associated to a non-ideal feature (see Figure 24), or
- the distance between two parallel planes associated to two non-ideal features (see Figure 25).

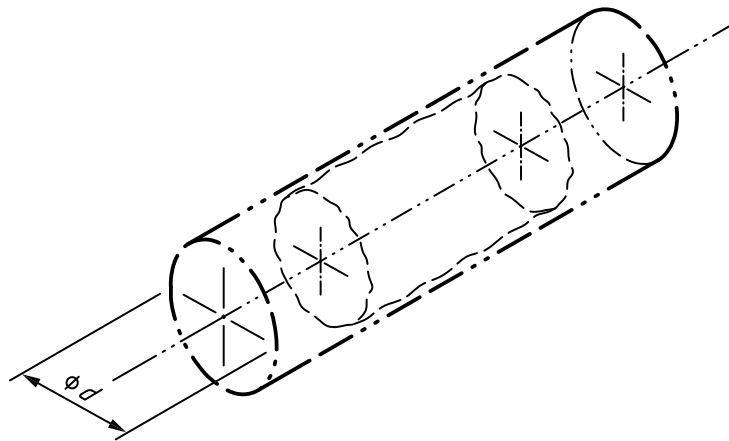

NOTE The non-ideal feature and the ideal cylinder are in contact.

**Figure 24 — Example of specification by dimension (diameter of a cylinder, *d*)**

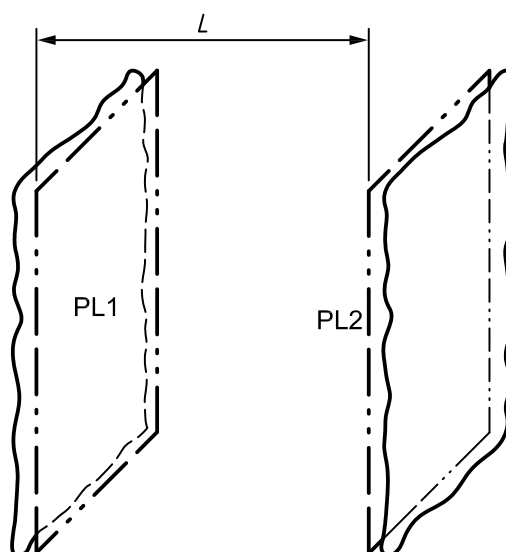

**Key**

- PL1 ideal plane 1  
 PL2 ideal plane 2

NOTE The non-ideal features and the ideal plane are in contact.

**Figure 25 — Example of specification by dimension (distance between two parallel planes,  $L$ )**

### 9.3 Specification by zone

A specification by zone limits the permissible deviation of a non-ideal feature inside a space. This space is limited by an ideal feature or by ideal features and can thus be characterized by

- the intrinsic characteristic of the ideal feature or ideal features, for instance the diameter of a cylinder, the distance between two planes or the identical diameter of a set of cylinders, and
- situation features of the ideal feature or ideal features, for instance the axis of a cylinder, the symmetry plane of two planes or the axis and plane of a set of parallel cylinders.

NOTE A specification by zone can also be defined as follows: the permissible value of the situation characteristic between a non-ideal feature (partition feature for instance) and an ideal feature (situation features of the zone).

### 9.4 Deviation

In the case of specification by dimension, the deviation is either

- the difference between the value of the intrinsic characteristic of the associated feature and the value of the intrinsic characteristic of the corresponding nominal feature, or
- the difference between the value of the situation characteristic between two associated features and the value of the situation characteristic between the two corresponding nominal features.

In the case of specification by zone, the deviation is the minimum possible value of the intrinsic characteristic of the ideal feature limiting the zone containing the non-ideal feature.

NOTE In the case of specification by zone, the deviation can also be defined as the value of the maximum distance of each point of a non-ideal feature to the ideal feature (e.g. the situation feature of the zone).

## 10 Verification

Verification is the provision of objective evidence that the workpiece fulfills the specification.

This is normally accomplished by first performing a measurement that provides a measurement result with an associated uncertainty. Subsequently, the measurement result is compared to the specification limit(s) taking into account the duality principle and the responsibility principle (see ISO 8015).

NOTE It is also possible to verify a workpiece using a “go”/“no go” gauge without establishing a numerical measurement result.

## Annex A (informative)

### Examples of applications to ISO 1101

#### A.1 Form tolerance

Consider an example of flatness tolerance according to ISO 1101 (see Figure A.1):

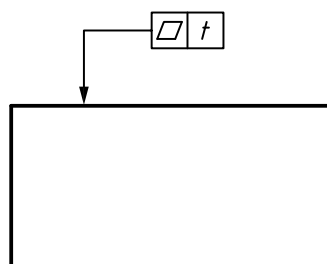

**Figure A.1 — Example of a flatness specification**

The following feature operations apply.

- a) The surface is obtained by partition, from the non-ideal surface model, of the non-ideal planar surface [see Figures A.2 a) and b)].

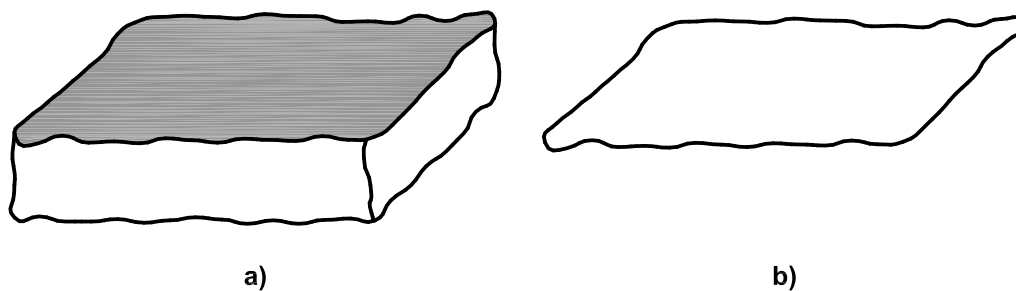

**Figure A.2 — Example of a feature operation: Partition**

- b) The symmetry plane of the tolerance zone is obtained by the association of an ideal feature of type plane with the partition feature; the maximum distance between each point of the partition feature and the situation feature of the plane shall be minimum (see Figure A.3).

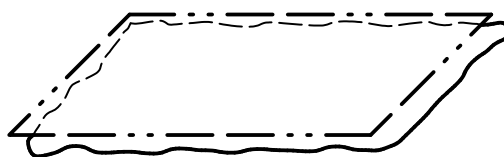

**Figure A.3 — Example of a feature operation: Association**

The specification is the following:

- by using the symmetry plane of the tolerance zone as the basis for the deviation of flatness, the form deviation is obtained by the evaluation of a characteristic, i.e. the maximum of the distances between each point of the partition feature and the associated plane; this maximum shall be less than or equal to  $t/2$  (which is the limit).

### A.2 Orientation tolerance

Consider an example of perpendicularity tolerance according to ISO 1101 (see Figure A.4).

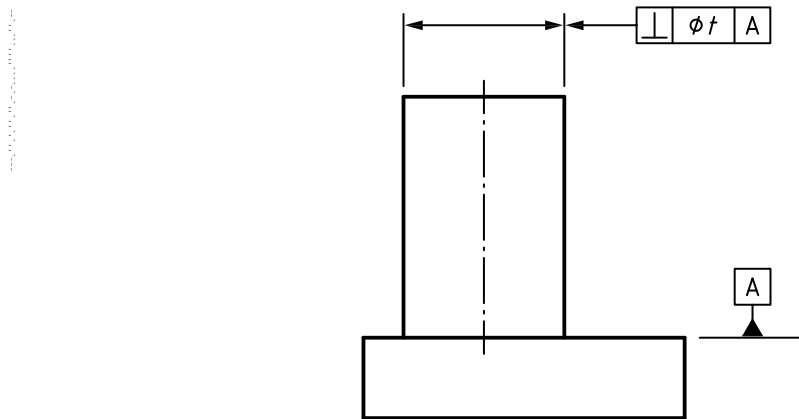

Figure A.4 — Example of an orientation specification

The following feature operations apply.

- a) The axis of the cylinder is obtained by
  - 1) partition, from the non-ideal surface model, of the non-ideal cylindrical surface [see Figures A.5 a) and b)],

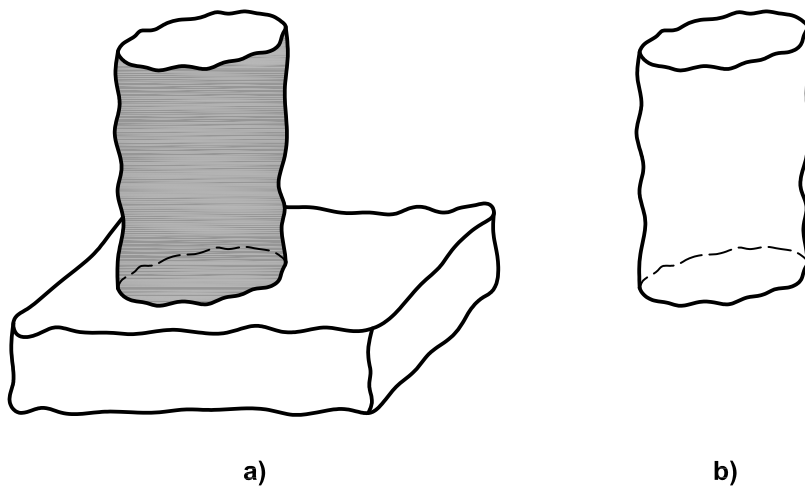

Figure A.5 — Example of a feature operation: Partition

2) association of an ideal feature of type cylinder [see Figures A.6 a) and b)],

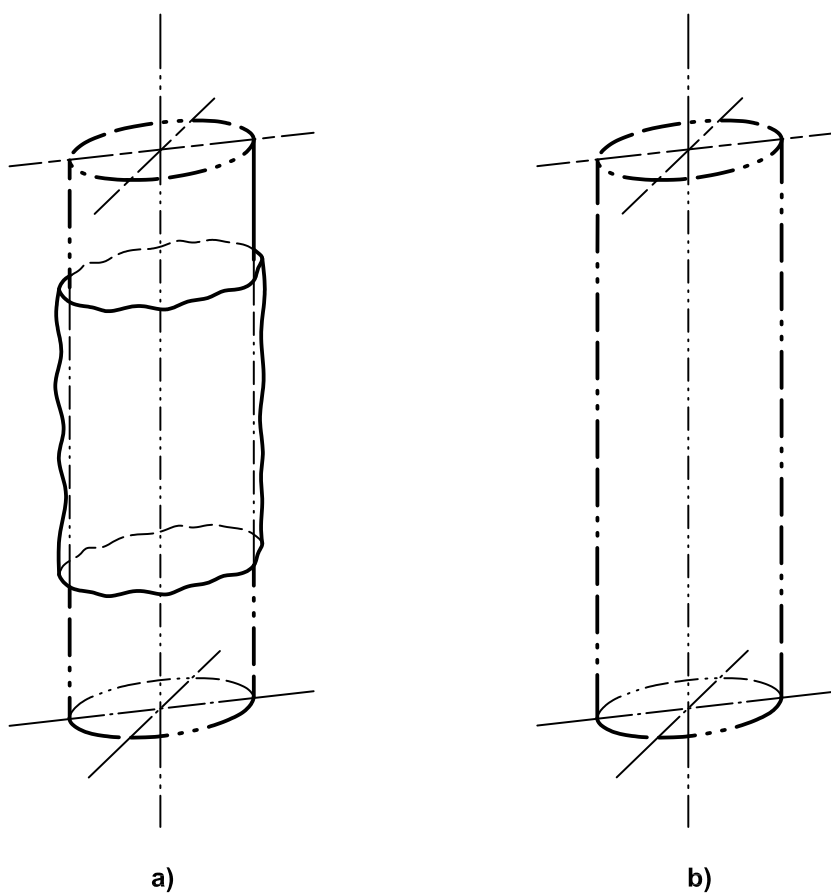
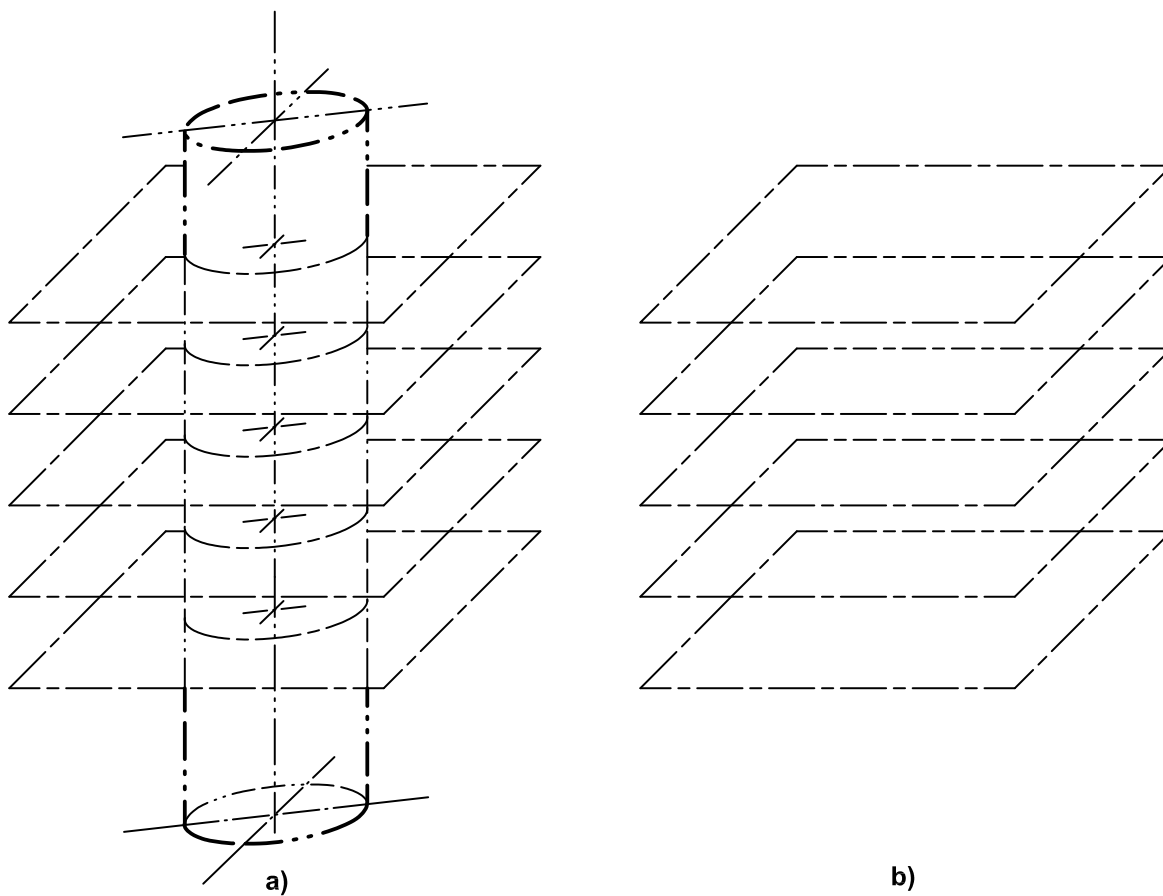

Figure A.6 — Example of a feature operation: Association

- 3) construction of planes perpendicular to the axis of the associated cylinder [see Figures A.7 a) and b)],



**Figure A.7 — Example of a feature operation: Construction and collection**

- 4) partition of non-ideal circular lines [see Figures A.8 a) and b)],

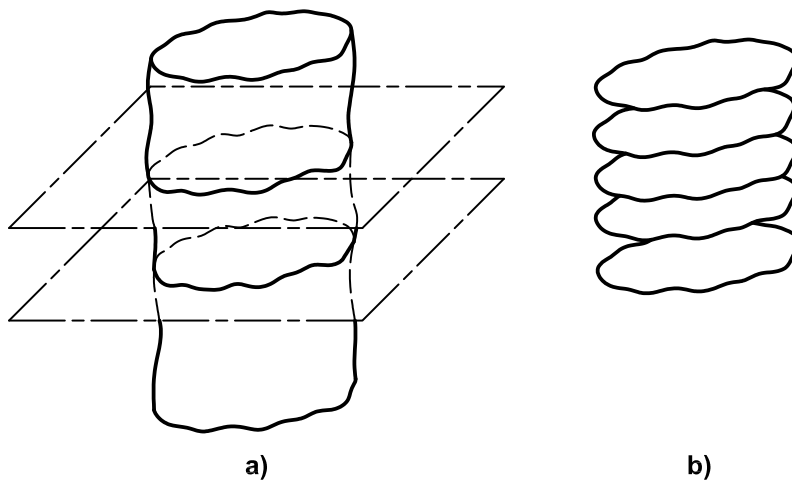

**Figure A.8 — Example of feature operation: Partition and collection**

- 5) association of ideal features of type circle [see Figures A.9 a) and b)], and

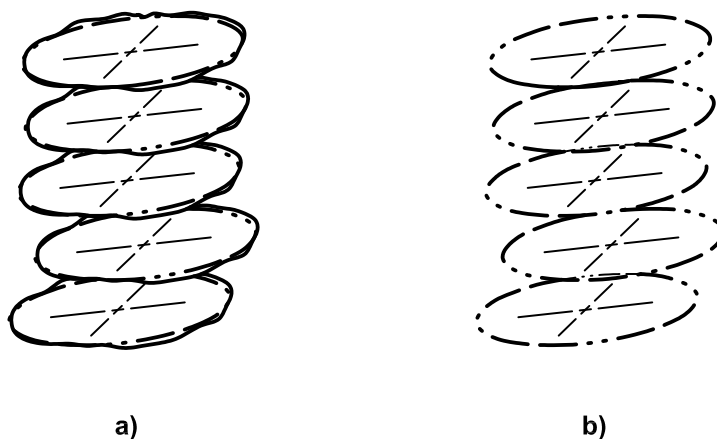

**Figure A.9 — Example of a feature operation: Association and Collection**

- 6) collection of all the centres of the ideal circles [see Figures A.10 a) and b)].

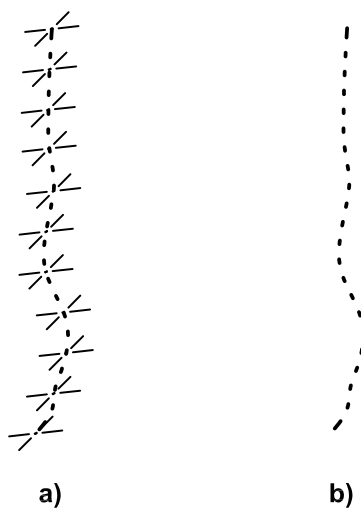

**Figure A.10 — Example of a feature operation: Collection**

- b) The datum surface A is obtained by

- 1) partition, from the non-ideal surface model, of the non-ideal planar surface corresponding to A [see Figures A.11 a) and b)], and

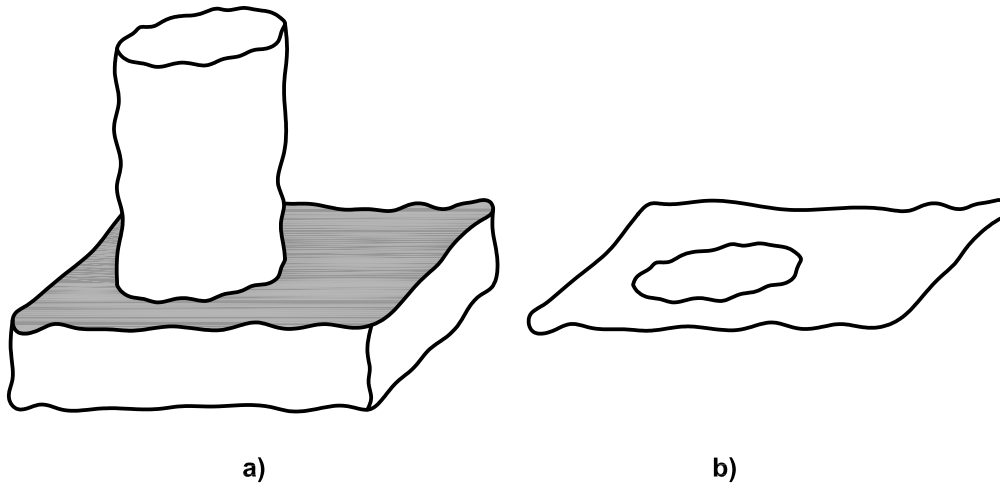

Figure A.11 — Example of a feature operation: Partition

- 2) association of an ideal feature of type plane, the situation feature of which is the datum [see Figures A.12 a) and b)].

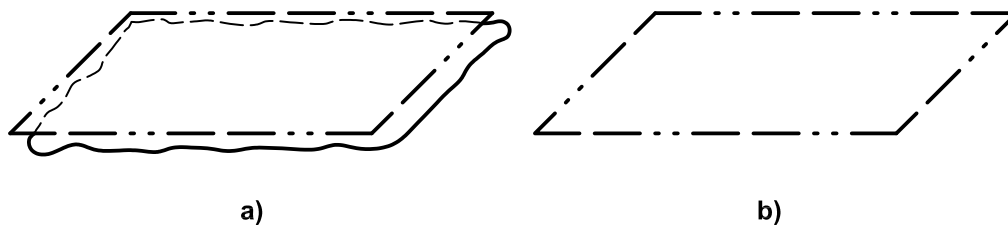

Figure A.12 — Example of a feature operations: Association

- c) The axis of the tolerance zone is obtained by association of an ideal feature of type straight line with the collected feature, the situation feature of the straight line is constrained to be perpendicular to the datum A, and the maximum distance between each point of the collection feature and the associated straight line shall be minimum (see Figure A.13).

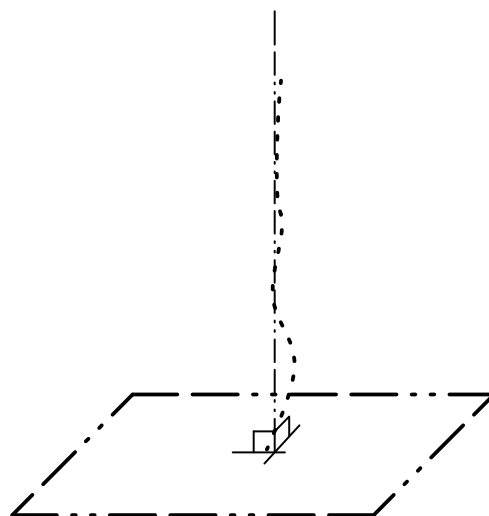

Figure A.13 — Example of a feature operation: Association and construction



The specification is the following.

- The orientation deviation is obtained by evaluation of a characteristic, i.e. the maximum of the distances between each point of the collected feature and the axis of the tolerance zone; this maximum shall be less than or equal to  $t/2$  (which is the limit).

### A.3 Location tolerance

Consider an example of position tolerance according to ISO 1101 (see Figure A.14).

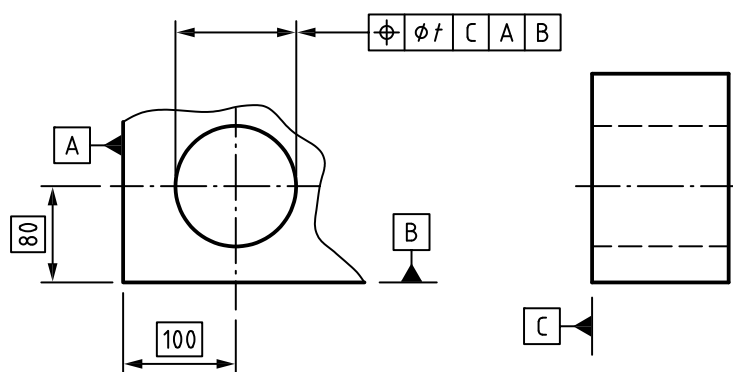

Figure A.14 — Example of a location specification

The following feature operations apply.

- a) The axis of the cylinder is obtained by
  - 1) partition, from the non-ideal surface model, of the non-ideal cylindrical surface [see Figures A.15 a) and b)],

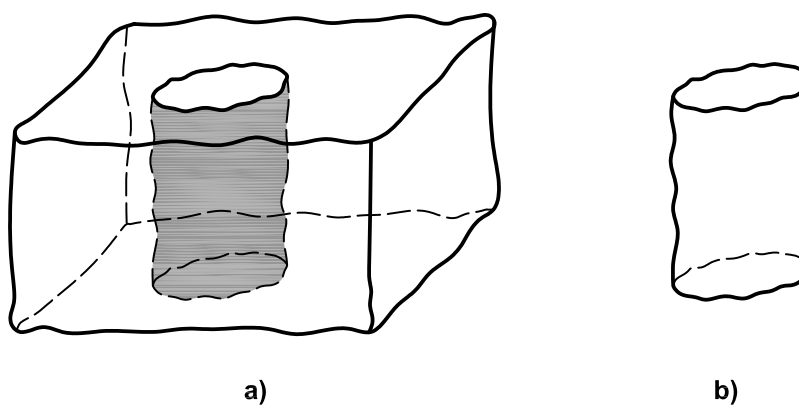

Figure A.15 — Example of a feature operation: Partition

2) association of an ideal feature of type cylinder [see Figures A.16 a) and b)],

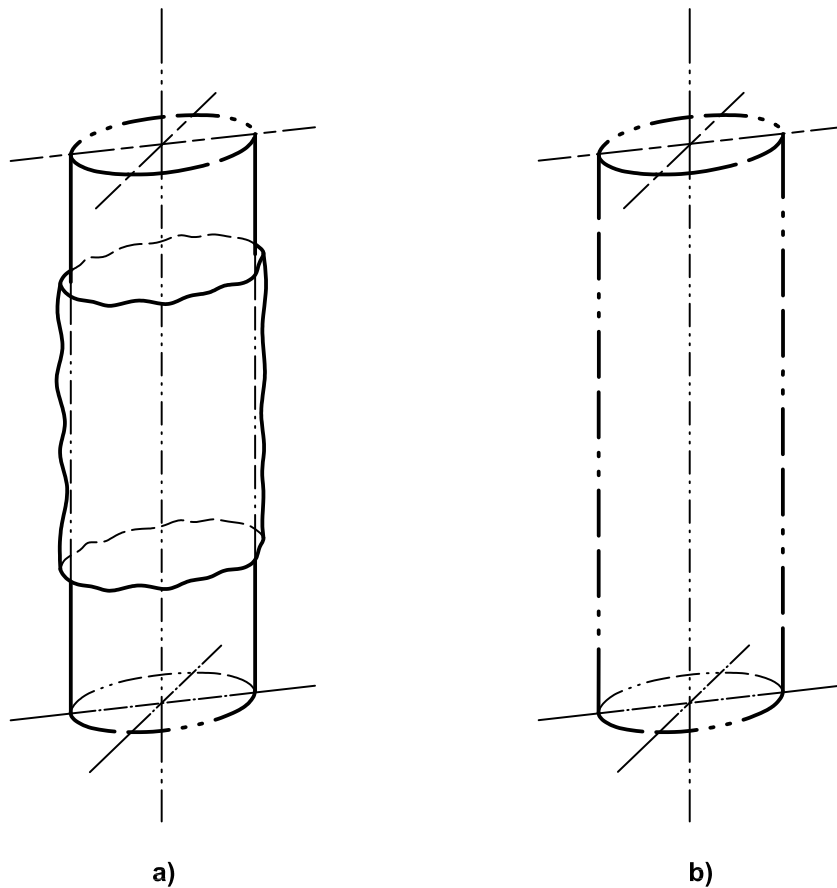

Figure A.16 — Example of a feature operation: Association

- 3) construction of planes perpendicular to the axis of the associated cylinder [see Figures A.17 a) and b)],

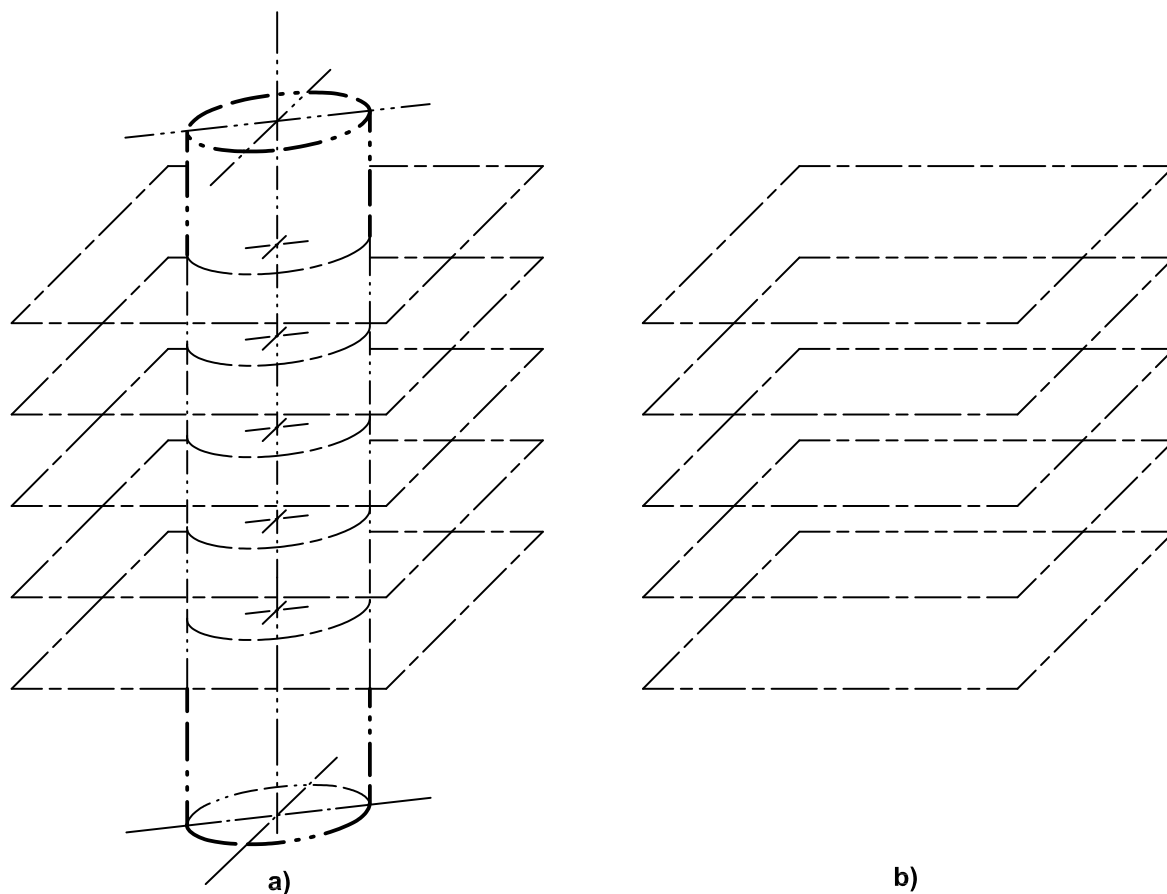

Figure A.17 — Example of a feature operation: Construction and collection

- 4) partition of non-ideal circular lines [see Figures A.18 a) and b)],

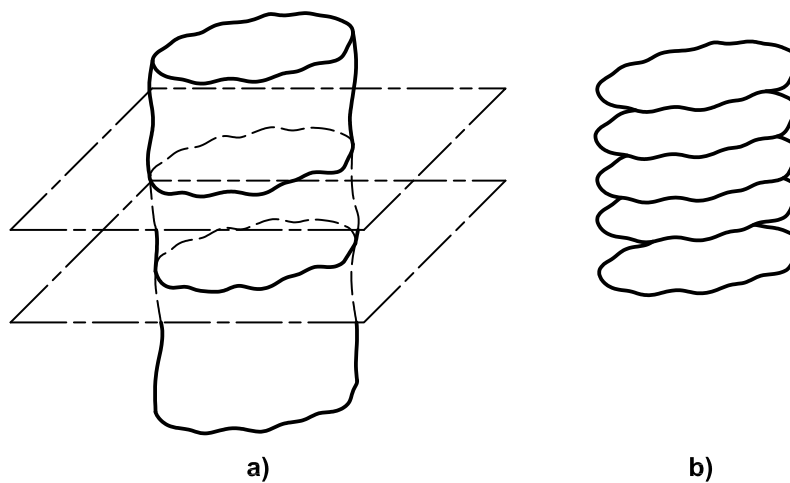
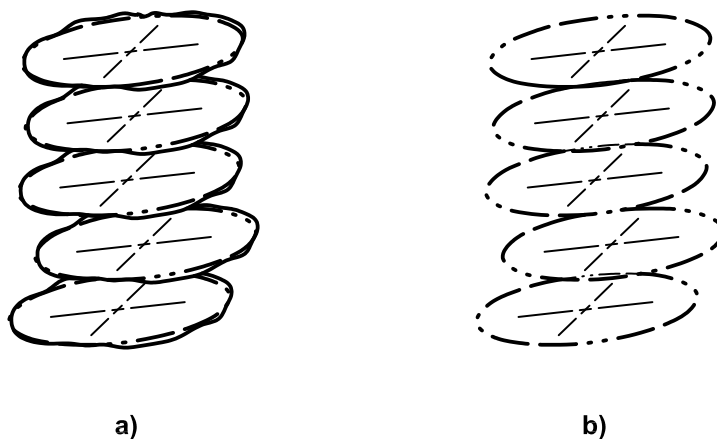

Figure A.18 — Example of feature operations: partition and collection

- 5) association of ideal features of type circle [see Figures A.19 a) and b)], and



**Figure A.19 — Example of a feature operations: Association and collection**

- 6) collection of all the centres of the ideal circles [see Figures A.20 a) and b)].

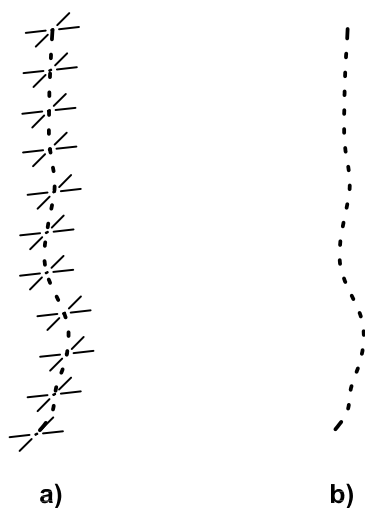

**Figure A.20 — Example of a feature operation: Collection**

- b) The datum surfaces C, A and B are obtained by

- 1) partition, from the non-ideal surface model, of the non-ideal planar surface corresponding to C [see Figures A.21 a) and b)],

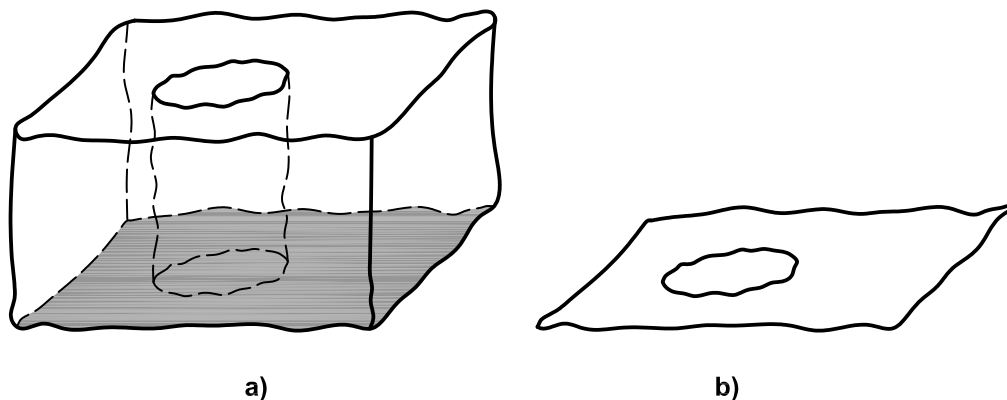

Figure A.21 — Example of a feature operation: Partition

- 2) association of an ideal feature of type plane, the situation feature of which is the datum C [see Figures A.22 a) and b)],

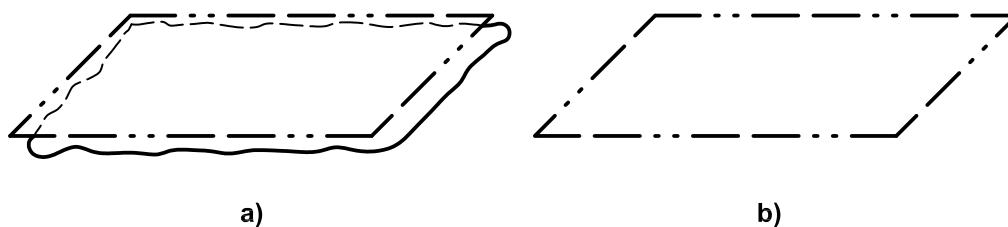

Figure A.22 — Example of a feature operation: Association

- 3) partition from the non-ideal surface model of the non-ideal planar surface corresponding to A [see Figures A.23 a) and b)],

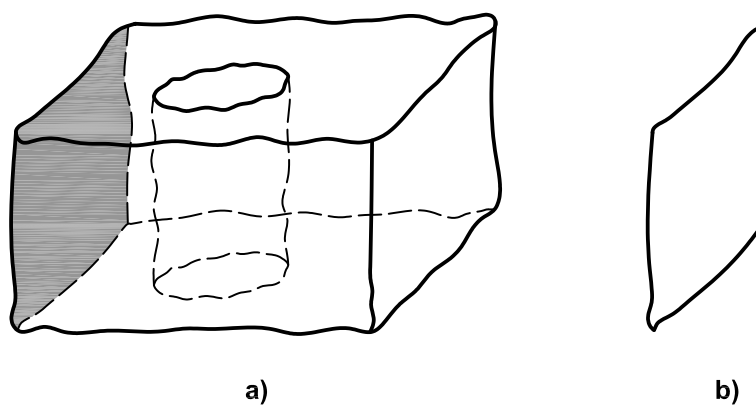
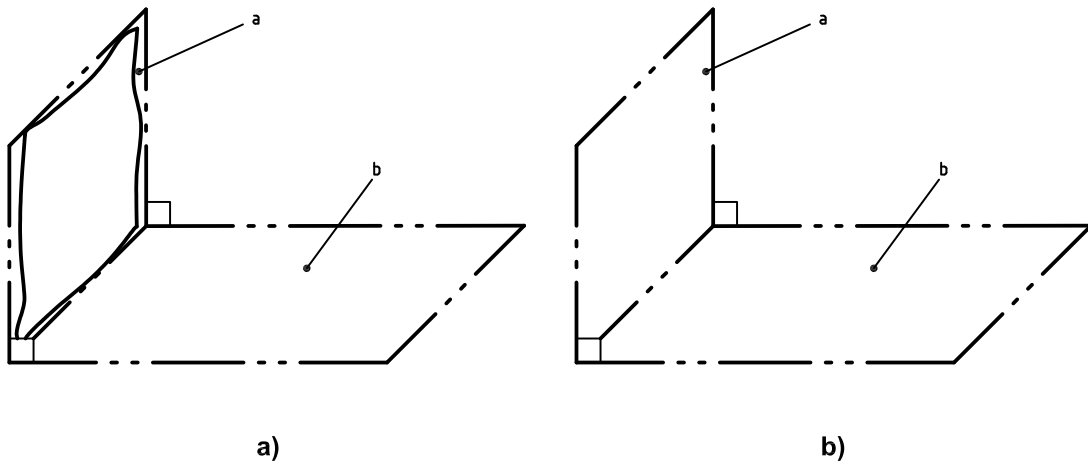

Figure A.23 — Example of a feature operation: Partition

- 4) association of an ideal feature of type plane, with a constraint of perpendicularity with the datum C, the situation feature of which is the datum A [see Figures A.24 a) and b)],



- a Datum A
- b Datum C

Figure A.24 — Example of a feature operation: Association and construction

- 5) partition from the non-ideal surface model of the non-ideal planar surface corresponding to B [see Figures A.25 a) and b)], and

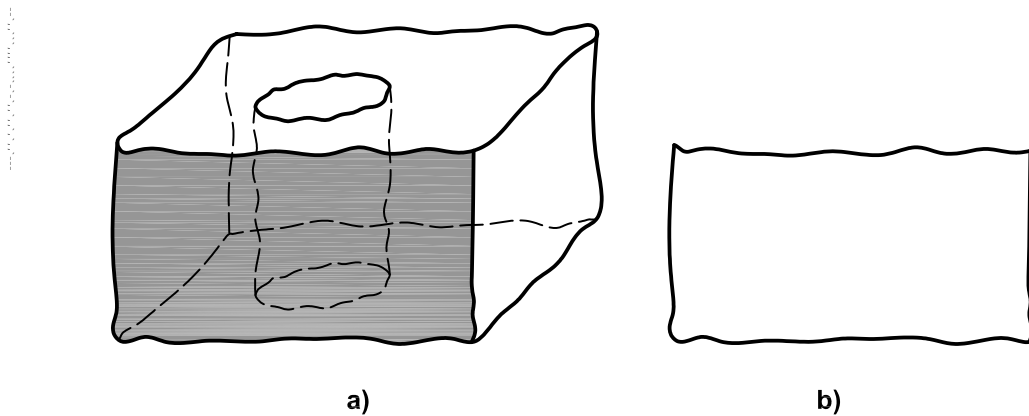
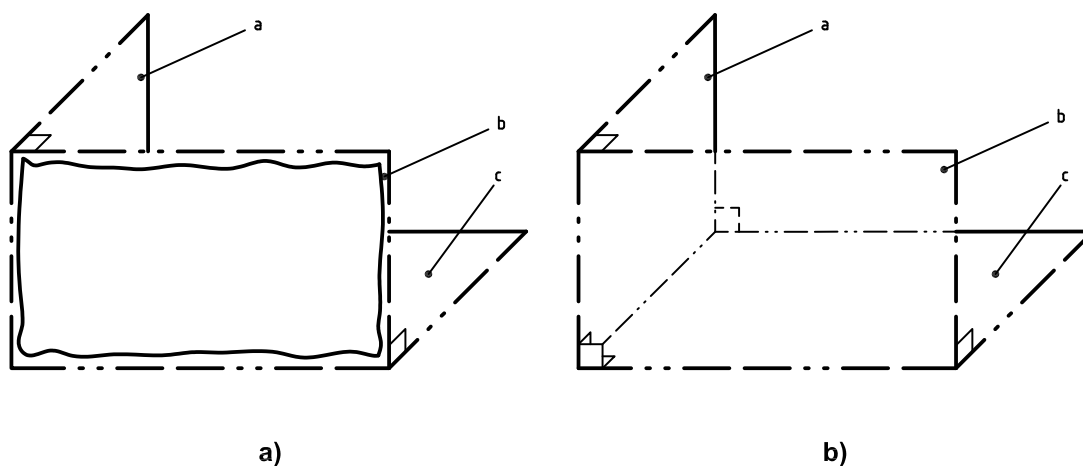

Figure A.25 — Example of a feature operation: Partition

- 6) association of an ideal feature of type plane, with a constraint of perpendicularity with datum C and datum A, the situation feature of which is the datum B [see Figures A.26 a) and b)]



- a Datum A
- b Datum B
- c Datum C

**Figure A.26 — Example of a feature operations: Association and construction**

- c) The axis of the tolerance zone is obtained by construction of an ideal feature; the situation feature of the straight line is constrained to be
- perpendicular to the datum C,
  - at a distance of 100 mm from the datum A, and
  - at a distance of 80 mm from the datum B.

See Figure A.27.

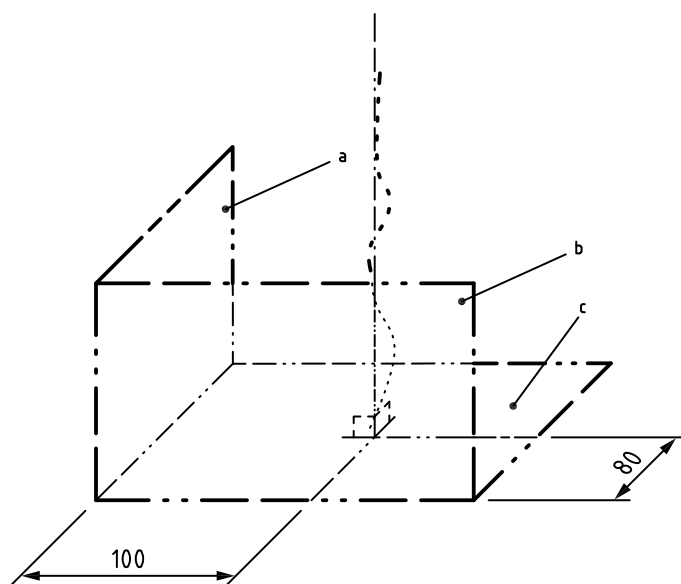

- a Datum A
- b Datum B
- c Datum C

**Figure A.27 — Example of a feature operation: Construction**

The specification is the following.

- The location deviation is obtained by evaluation of a characteristic, i.e. the maximum of the distances between each point of the collected feature and the constructed straight line; this maximum shall be less than or equal to  $t/2$  (which is the limit).



## Annex B (informative)

### Mathematical symbols and definitions

#### B.1 General

This annex develops a mathematical system of notation and definition of the concepts of this part of ISO 17450. Some basic mathematical notations used to describe the different concepts of specification are given in Table B.1.

**Table B.1 — Basic mathematical notations**

Quantity	Symbol
Vectors	“Times New Roman” italic bold-face ( $T, u, \dots$ )
Location vector	The location vector of a point P in relation to to the origin of indicating line (O), or the 2 points (O, P), or the vector OP is noted P
Functions	A real number or vector symbol followed by the parameters of the function in parentheses [ $r(P)$ , dia(CY), ...]
Sets	“Times New Roman” italic upper-case letters ( $E, F, \dots$ )

The symbol may be subscripted to distinguish between distinct quantities.

A set of elements is denoted in parentheses  $\{ \}$  and each element is subscripted preferably with  $i, j, k$  or  $l$ . Thus, a set of vectors is denoted by

- $\{u_i\}$  if the set is not denumerable (infinite set), or
- $\{u_i, i = 1, \dots, n\}$  if the set is denumerable and the number of elements is  $n$  (finite set).

Basic mathematical operators are given in Table B.2.

**Table B.2 — Basic mathematical operators**

Operator	Symbol
Norm 2	The norm 2 (magnitude) of a vector $u$ is denoted $ u $
Scalar product	The scalar product (dot product) of two vectors $u$ and $v$ is denoted $u \cdot v$
Vector product	The vector product (cross product) of two vectors $u$ and $v$ is denoted $u \times v$

The nominal model of the workpiece is denoted by N. The non-ideal surface model of the workpiece is denoted by  $S_p$ .

## B.2 Features

### B.2.1 Ideal features

#### B.2.1.1 Type

Ideal features are characterized by type (see Table B.3), consequently, the most commonly used ideal features are denoted by two letters identifying their type.

**Table B.3 — Type**

Type	Designation	Type	Designation
Point	PT	Circle	CR
Cylinder	CY	Cone	CO
Straight line	SL	Plane	PL
Sphere	SP	Torus	TO
...	...	...	...

A set of a plane is denoted by

—  $\{PL_i\}$  if the set is not denumerable, or

—  $\{PL_i, i = 1, \dots, n\}$  if the set is denumerable and the number of elements is  $n$ .

#### B.2.1.2 Invariance class

An ideal feature belongs to one of the seven invariance classes denoted by the symbols listed in Table B.4.

**Table B.4 — Invariance class**

Invariance class	Symbol
Complex	$C_X$
Prismatic	$C_T$
Revolute	$C_R$
Helical	$C_H$
Cylindrical	$C_C$
Planar	$C_P$
Spherical	$C_S$
NOTE For the prismatic class, the chosen symbol is $C_T$ for translation.	

### B.2.1.3 Situation feature

The situation features are of the following types: point, straight line, plane or helix; they are functions of features. Thus, they are denoted as functions, specifically as described in Table B.5.

**Table B.5 — Situation feature**

Invariance class		Type	Feature	Situation feature	Type of situation feature	Designation
$C_R$	Revolute	Circle	CR	Axis Plane (of the circle) Centre	Straight line Plane Point	axis(CR) plane(CR) centre(CR)
		Cone	CO	Axis Apex	Straight line Point	axis(CO) apex(CO)
		Torus	TO	Axis Centre	Straight line Point	axis(TO) centre(TO)
$C_C$	Cylindrical	Cylinder	CY	Axis	Straight line	axis(CY)
$C_S$	Spherical	Sphere	SP	Centre	Point	centre(SP)
	...	...	...	...	...	...

### B.2.2 Non-ideal features

Non-ideal features are denoted symbolically as sets of points in space. If the nature of the non-ideal features is known, they are denoted by

- $P$  if their nature is a point,
- $L$  if their nature is a line, or
- $S$  if their nature is a surface.

## B.3 Characteristics

### B.3.1 Intrinsic characteristics of ideal features

The intrinsic characteristics are functions of features, so they are denoted as functions of these features, particularly as described in Table B.6.

**Table B.6 — Intrinsic characteristics**

Type	Feature	Intrinsic characteristics	Designation
Circle	CR	radius diameter	rad(CR) dia(CR)
Cylinder	CY	radius diameter	rad(CY) dia(CY)
Sphere	SP	radius diameter	rad(SP) dia(SP)
Cone	CO	apex angle	$a$ (CO)
...	...	...	...

## B.3.2 Situation characteristics between ideal features

### B.3.2.1 Location characteristics

The distances (see Table B.7) to be defined are as follows:

- Distance(PT, PT) =  $d(\text{PT}, \text{PT})$ ,
- Distance(PT, SL) =  $d(\text{PT}, \text{SL})$ ,
- Distance(PT, PL) =  $d(\text{PT}, \text{PL})$ ,
- Distance(SL, SL) =  $d(\text{SL}, \text{SL})$ ,
- Distance(SL, PL) =  $d(\text{SL}, \text{PL})$ ,
- Distance(PL, PL) =  $d(\text{PL}, \text{PL})$ .

### B.3.2.2 Orientation characteristics

The angles (see Table B.8) to be defined are as follows:

- Angle(SL, SL) =  $a(\text{SL}, \text{SL})$ ,
- Angle(SL, PL) =  $a(\text{SL}, \text{PL})$ ,
- Angle(PL, PL) =  $a(\text{PL}, \text{PL})$ .

These angles are angles between the director vector of straight lines and/or normal vector to planes. First, the angle between two vectors shall be defined.

let  $u_1$  be a unit vector, and

let  $u_2$  be a unit vector,

then

$$\text{angle}(u_1, u_2) = a(u_1, u_2) = \text{Arccos}(|u_1 \cdot u_2|) \text{ with } a(u_1, u_2) \in [0, \pi/2]$$

Subsequently, the angles between situation features can be defined.

Table B.7 — Distances

Features	Distances
Let $PT_1$ be a point. Let $PT_2$ be a point.	$d(PT_1, PT_2) =  PT_1 - PT_2 $
Let $PT_1$ be a point. Let $SL_2$ be a straight line passing through the point $A_2$ and director unit vector $u_2$ .	$d(PT_1, SL_2) =  (A_2 - PT_1) \times u_2 $
Let $PT_1$ be a point. Let $PL_2$ be a plane passing through the point $A_2$ and normal unit vector $u_2$ .	$d(PT_1, PL_2) =  (A_2 - PT_1) \cdot u_2 $
Let $SL_1$ be a straight line passing through the point $A_1$ and director unit vector $u_1$ . Let $SL_2$ be a straight line passing through the point $A_2$ and director unit vector $u_2$ .	If $u_1 \times u_2 \neq 0$ , then $d(SL_1, SL_2) =  (A_2 - A_1) \cdot (u_1 \times u_2)  /  u_1 \times u_2 $ If $u_1 \times u_2 = 0$ , then $d(SL_1, SL_2) =  (A_2 - A_1) \times u_1 $
Let $SL_1$ be a straight line passing through the point $A_1$ and director unit vector $u_1$ . Let $PL_2$ be a plane passing through the point $A_2$ and normal unit vector $u_2$ .	If $u_1 \cdot u_2 = 0$ , then $d(SL_1, PL_2) =  (A_2 - A_1) \cdot u_2 $ If $u_1 \cdot u_2 \neq 0$ , then $d(SL_1, PL_2) = 0$
Let $PL_1$ be a plane passing through the point $A_1$ and normal unit vector $u_1$ . Let $PL_2$ be a plane passing through the point $A_2$ and normal unit vector $u_2$ .	If $u_1 \times u_2 = 0$ , then $d(PL_1, PL_2) =  (A_2 - A_1) \cdot u_2 $ If $u_1 \times u_2 \neq 0$ , then $d(PL_1, PL_2) = 0$

Table B.8 — Angles

Features	Angles
Let $SL_1$ be a straight line passing through the point $A_1$ and director unit vector $u_1$ . Let $SL_2$ be a straight line passing through the point $A_2$ and director unit vector $u_2$ .	$a(SL_1, SL_2) = a(u_1, u_2)$
Let $SL_1$ be a straight line passing through the point $A_1$ and director unit vector $u_1$ . Let $PL_2$ be a plane passing through the point $A_2$ and normal unit vector $u_2$ .	$a(SL_1, PL_2) = \pi/2 - a(u_1, u_2)$
Let $PL_1$ be a plane passing through the point $A_1$ and normal unit vector $u_1$ . Let $PL_2$ be a plane passing through the point $A_2$ and normal unit vector $u_2$ .	$a(PL_1, PL_2) = a(u_1, u_2)$

**B.3.2.3 Signed characteristics**

(See 7.3.)

The signed distances (see Table B.9) to be defined are

- signed distance(PT, PL) =  $d_s$ (PT, PL),
- signed distance(SL, PL) =  $d_s$ (SL, PL), and
- signed distance(PL, PL) =  $d_s$ (PL, PL).

**Table B.9 — Signed distances**

Features	Signed distances
Let $SL_1$ be a straight line passing through the point $A_1$ and director unit vector $u_1$ .  Let $SL_2$ be a straight line passing through the point $A_2$ and director unit vector $u_2$ .	If $u_1 \times u_2 \neq 0$ , then $d_s(SL_1, SL_2) = d_s(SL_2, SL_1)$ $= (A_2 - A_1) \cdot (u_1 \times u_2) /  u_1 \times u_2 $ If $u_1 \times u_2 = 0$ , then $d_s(SL_1, SL_2)$ and $d_s(SL_2, SL_1)$ are undefined.
Let $PT_1$ be a point.  Let $PL_2$ be a plane passing through the point $A_2$ and normal unit vector $u_2$ .	$d_s(PT_1, PL_2) = d_s(PL_2, PT_1) = (PT_1 - A_2) \cdot u_2$
Let $SL_1$ be a straight line passing through the point $A_1$ and director unit vector $u_1$ .  Let $PL_2$ be a plane passing through the point $A_2$ and normal unit vector $u_2$ .	If $u_1 \cdot u_2 = 0$ , then $d_s(SL_1, PL_2) = d_s(PL_2, SL_1) = (A_1 - A_2) \cdot u_2$ If $u_1 \cdot u_2 \neq 0$ , then $d_s(SL_1, PL_2) = d_s(PL_2, SL_1) = 0$
Let $PL_1$ be a plane passing through the point $A_1$ and normal unit vector $u_1$ .  Let $PL_2$ be a plane passing through the point $A_2$ and normal unit vector $u_2$ .	If $u_1 \times u_2 = 0$ , then $d_s(PL_1, PL_2) = (A_2 - A_1) \cdot u_1$ $d_s(PL_2, PL_1) = (A_1 - A_2) \cdot u_2$ If $u_1 \times u_2 \neq 0$ , then $d_s(PL_1, PL_2) = d_s(PL_2, PL_1) = 0$
NOTE The function of signed distance between two parallel planes is not symmetric. It is so, because it is preferable to have a change of sign when the planes cross themselves, and that is antinomic with the symmetry of the function.	

The signed angles (see Table B.10) to be defined are:

- signed angle(SL, SL) =  $a_s$ (SL, SL),
- signed angle(SL, PL) =  $a_s$ (SL, PL), and
- signed angle(PL, PL) =  $a_s$ (PL, PL).

First, the signed angle between two vectors is to be defined.

Let  $u_1$  be a unit vector, and

let  $u_2$  be a unit vector,

then

$$\text{Angle}(u_1, u_2) = a_s(u_1, u_2) = \arccos(u_1 \cdot u_2) \text{ with } a(u_1, u_2) \in [0, \pi]$$

**Table B.10 — Signed angles**

Features	Signed angles
Let $SL_1$ be a straight line passing through the point $A_1$ and director unit vector $u_1$ . Let $SL_2$ be a straight line passing through the point $A_2$ and director unit vector $u_2$ .	$a_s(SL_1, SL_2) = a_s(SL_2, SL_1) = a_s(u_1, u_2)$
Let $SL_1$ be a straight line passing through the point $A_1$ and director unit vector $u_1$ . Let $PL_2$ be a plane passing through the point $A_2$ and normal unit vector $u_2$ .	$a_s(SL_1, PL_2) = a_s(PL_2, SL_1) = \pi/2 - a_s(u_1, u_2)$
Let $PL_1$ be a plane passing through the point $A_1$ and normal unit vector $u_1$ . Let $PL_2$ be a plane passing through the point $A_2$ and normal unit vector $u_2$ .	$a_s(PL_1, PL_2) = a_s(PL_2, PL_1) = a_s(u_1, u_2)$

### B.3.3 Situation characteristics between non-ideal and ideal features

#### B.3.3.1 Distance between non-ideal and ideal features

The situation characteristics between non-ideal features and ideal features are based on the distances between each point of the non-ideal feature and ideal feature.

Let  $XX$  be an ideal feature,

let  $E$  be a non-ideal feature,

let  $P$  be a point of  $E$ ,

then

$$\text{Distance}(P, XX) = d(P, XX) = \min d(P, P_{XX}) = \min |P - P_{XX}|$$

where

$$P_{XX} \in XX$$

After that, the maximum, minimum and quadratic distances can be defined (see Table B.11). Other distances could also be defined.

Table B.11 — Distance between non-ideal and ideal features

Type	Notation and definition
Maximum distance	$d_{\max}(E, XX) = \max d(P_E, XX)$ $P_E \in E$
Minimum distance	$d_{\min}(E, XX) = \min d(P_E, XX)$ $P_E \in E$
Quadratic distance	$d_{\text{quad}}(E, XX) = \frac{\int_E d(P_{dE}, XX)^2 dE}{\int_E dE}$ <p>with <math>dE</math>, an infinitesimal part of <math>E</math> and <math>P_{dE}</math> the barycentre of <math>dE</math></p>

**B.3.3.2 Signed distance between non-ideal feature and ideal surface**

For an ideal surface, the situation characteristics could be based on the signed distances between the points of the non-ideal features and the ideal surface.

- Let  $XX$  be an ideal surface,
- let  $E$  be a non-ideal feature,
- let  $P$  be a point of  $E$ ,
- signed distance( $P, XX$ ) =  $d_s(P, XX)$

If  $XX$  is a plane passing through the point  $A$  and with a normal unit vector  $u$ , then

$$d_s(P, XX) = (\mathbf{A} - \mathbf{P}) \cdot \mathbf{u}$$

as previously defined.

If  $XX$  is a closed surface (cylinder, sphere, cone, ...) then

$$d_s(P, XX) = d(P, XX) \cdot \text{side}(P, XX)$$

with  $\text{side}(P, XX) = 1$  if  $P$  is inside the surface  $XX$

with  $\text{side}(P, XX) = -1$  if  $P$  is outside the surface  $XX$

For other type of surfaces, a face has to be defined as the positive one; the other will be the negative one.

After that, the maximum signed distance and the minimum signed distance can be defined (see Table B.12). Other distances could also be defined.



**Table B.12 — Signed distance between non-ideal and ideal features**

Type	Notation and definition
Maximum signed distance	$d_{\text{smax}}(E, XX) = \max_{P_E \in E} d_s(P_E, XX)$
Minimum signed distance	$d_{\text{smin}}(E, XX) = \min_{P_E \in E} d_s(P_E, XX)$

### B.3.3.3 Signed distance with respect to material between part of actual surface of workpiece and ideal feature

For a part of the non-ideal surface model of the workpiece, the situation characteristics could be based on the signed distances with respect to location of material.

Let  $XX$  be an ideal feature,

let  $S_p$  be the non-ideal surface model of the workpiece,

let  $E$  be a part of  $S_p$ ,

let  $P$  be a point of  $E$ ,

let  $P_{XX}$  be the point of  $XX$  which minimizes  $d(P, P_{XX})$ ,

then

Material distance( $P, XX$ ) =  $d_{\text{mat}}(P, XX) = d(P, XX) \cdot \text{mat}(P, P_{XX})$

with  $\text{mat}(P, P_{XX}) = 1$  if  $P_{XX}$  is external material side

and  $\text{mat}(P, P_{XX}) = -1$  if  $P_{XX}$  is internal material side.

After that, the maximum signed distance and the minimum signed distance with respect to material can be defined (see Table B.13). Other distances could also be defined.

**Table B.13 — Material distance between non-ideal and ideal features**

Type	Notation and definition
Maximum material distance	$d_{\text{mat max}}(E, XX) = \max_{P_E \in E} d_{\text{mat}}(P_E, XX)$
Minimum material distance	$d_{\text{mat min}}(E, XX) = \min_{P_E \in E} d_{\text{mat}}(P_E, XX)$

## B.4 Operations

### B.4.1 Feature operations

#### B.4.1.1 Partition

A standardized generic criterion has yet to be defined for partition.

#### B.4.1.2 Extraction

A standardized generic criterion has yet to be defined for extraction.

#### B.4.1.3 Filtration

A standardized generic criterion has yet to be defined for filtration.

#### B.4.1.4 Collection

The collection of two or more features is denoted symbolically as a set of features.

$$\text{Collection } (E, F) = \{E, F\}$$

The collection of a non-denumerable set of features is simply denoted by  $\{XX_i\}$ .

#### B.4.1.5 Association

An association identifies one or more features, which maximize (or minimize) an objective subject to a set of constraints. The constraints are equalities or inequalities involving the values of characteristics as defined in B.3. The objective is an expression also involving the values of characteristics.

An association is denoted as a set of features with conditions (constraints and objective):

$$\{XX_i, i=1, \dots, n\} \left| \begin{array}{l} C_1 \\ C_2 \\ \dots \\ C_m \\ \text{maximize } O \end{array} \right.$$

where  $XX_i$  are the fitted features,  $n$  is the number of fitted features,  $C_j$  are the constraints,  $m$  is the number of constraints and  $O$  is the objective.

For example the cylinder  $CY$ , inscribed in the surface  $E$  and of maximum diameter, is defined as:

$$CY \left| \begin{array}{l} d_{\text{cmax}}(E, CY) \leq 0 \\ \text{maximize } \text{dia}(CY) \end{array} \right.$$

If the cylinder has to be perpendicular to a plane  $PL$ ,  $CY$  will be defined as:

$$CY \left| \begin{array}{l} d_{\text{cmax}}(E, CY) \leq 0 \\ a[\text{axis}(CY), PL] = \pi/2 \\ \text{maximize } \text{dia}(CY) \end{array} \right.$$

### B.4.1.6 Construction

A construction identifies one or more features, which satisfy a set of constraints. The constraints are equalities or inequalities involving the values of characteristics as defined in B.3.

The constraints limit the values of characteristics.

A construction is denoted as a set of features with constraints:

$$\{XX_i, i=1, \dots, n\} \left| \begin{array}{l} C_1 \\ C_2 \\ \dots \\ C_m \end{array} \right.$$

where  $XX_i$  are the constructed features,  $n$  is the number of constructed features,  $C_j$  are the constraints and  $m$  is the number of constraints.

For example, the cylinder of diameter 30, the axis of which is perpendicular to the plane PL and passes through the point PT, is defined by:

$$CY \left| \begin{array}{l} a[\text{axis}(CY), PL] = \pi/2 \\ d[\text{axis}(CY), PT] = 0 \\ \text{dia}(CY) = 30 \end{array} \right.$$

If there is an infinite set of solutions, as for example, the set of planes which are perpendicular to the cylinder CY, the notation will be

$$\{PL_i\} \left| a[PL_i, \text{axis}(CY)] = \pi/2 \right.$$

### B.4.2 Evaluation

An evaluation identifies a characteristic. The value of this characteristic shall satisfy an inequality or inequalities with respect to a limit or limits. An evaluation is denoted as constraints on a characteristic:

$$l \leq \text{char}$$

$$\text{char} \leq l$$

$$l_1 \leq \text{char} \leq l_2$$

where  $l$ ,  $l_1$  and  $l_2$  are limits and "char" is a characteristic.

For example, in the case of a distance between two points:

Let  $PT_1$  and  $PT_2$  be two points, and

let 98,05 and 100,01 be the limits of the distance,

then

$$98,05 \leq d(PT_1, PT_2) \leq 100,01$$

For example, in the case of a location of axes of three cylinders:

Let  $\{L_i, i = 1, 2, 3\}$  be a set of three cylinder axes,

let  $\{SL_i, i = 1, 2, 3\}$  be a set of three axes of three cylindrical zones in best location, and

let 0,025 be the limit,

then, the evaluation is defined by

$$\max d_{\max}(L_i, SL_i) \leq 0,025$$

$$i = 1, 2, 3$$

## B.5 Specification

### B.5.1 Specification by dimension

A specification by dimension is a condition on the characteristic on an ideal feature or between two ideal features. For example, in the case of a distance between two points, see B.4.2.

### B.5.2 Specification by zone

A specification by zone is a condition on the distances between non-ideal features (extracted features) and ideal features (zone situation features).

For example, in the case of a location of axes of three cylinders, see B.4.2.

## B.6 Deviation

The deviation is the difference between the values of intrinsic characteristics (or the values of situation characteristics) of, or between, associated features and nominal features.

For the distance between two points (see B.5.1), the value of the situation characteristic between associated features is given by

$$d(PT_1, PT_2)$$

For the location of axes of the three cylinders (see B.5.2), the value of the intrinsic characteristic of the associated feature is given by

$$\max d_{\max}(L_i, SL_i)$$

$$i = 1, 2, 3$$

## Annex C (informative)

### Comparison between tolerancing and metrology

The first conceptual representation of a workpiece is defined by the nominal model. The specification is defined by the non-ideal surface model (see Figure C.1).

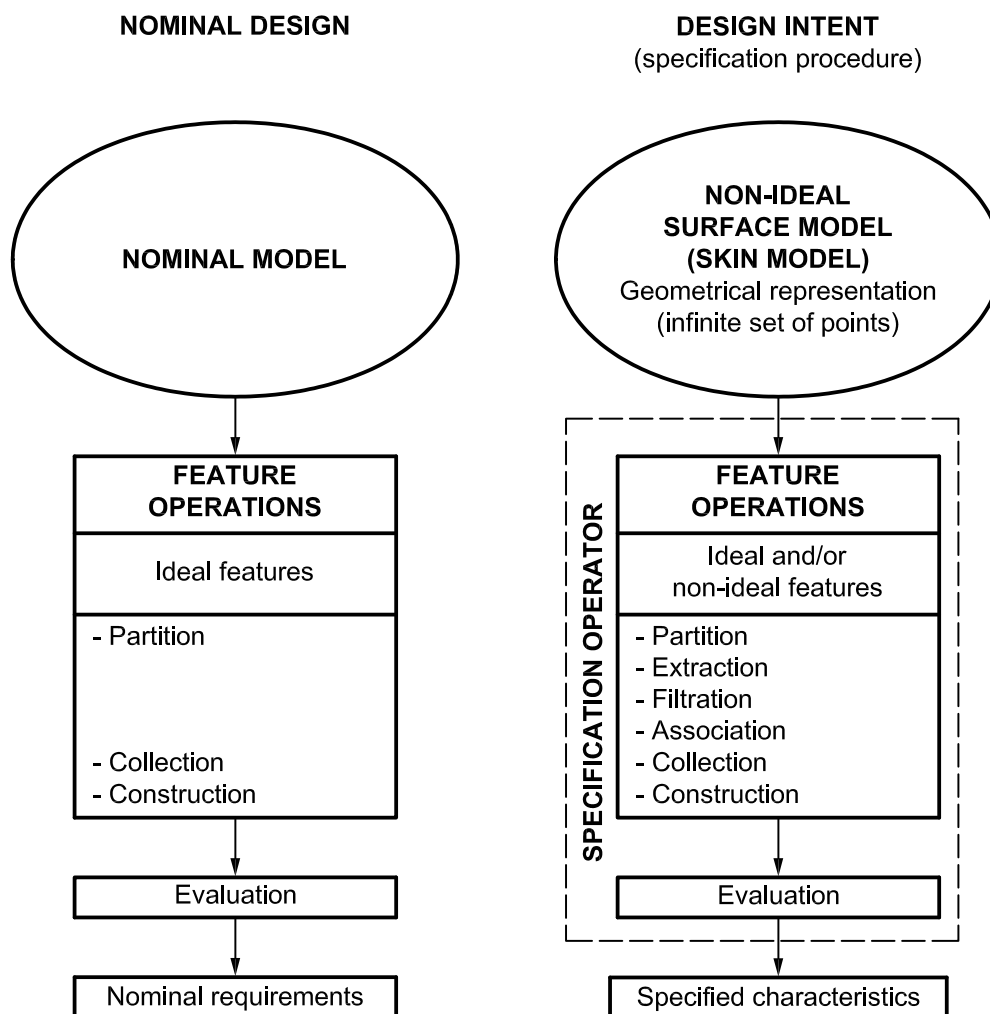

**Figure C.1 — Comparison between nominal design and design intent**

The parallel procedures between “Design intent” and the “Verification of manufactured workpieces for compliance with design intent” are illustrated by Figure C.2.

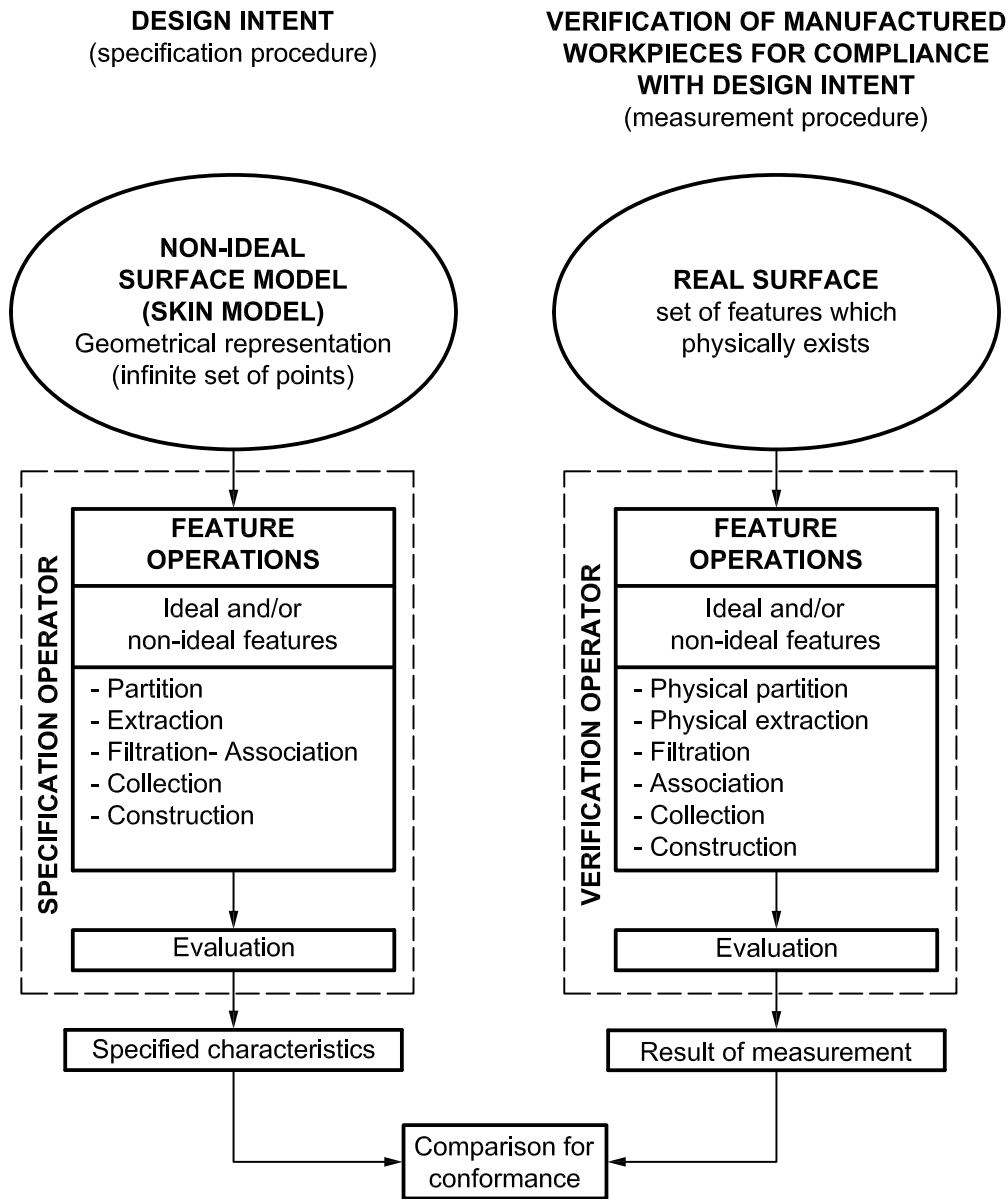
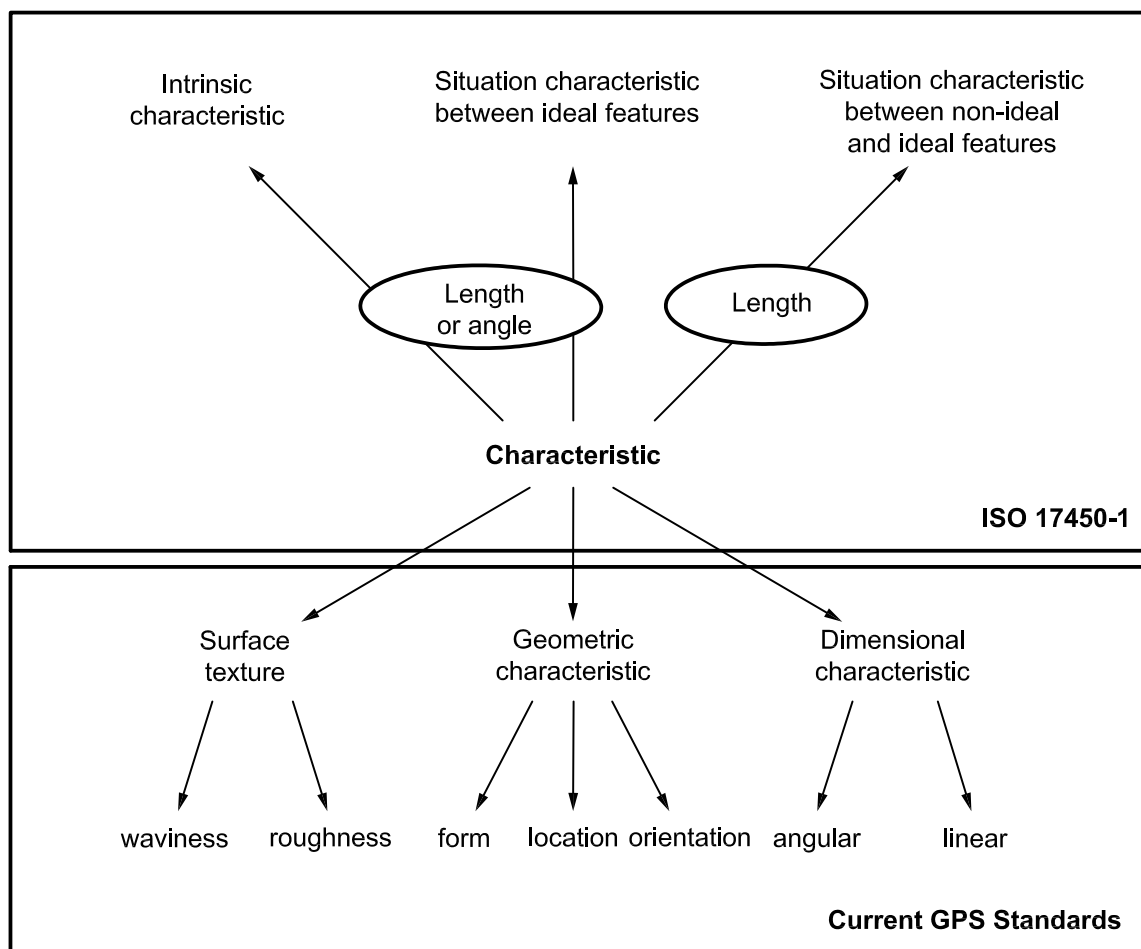

Figure C.2 — Parallel specification and measurement procedures

## Annex D (informative)

### Concept diagram for characteristics

The following diagram (Figure D.1) illustrates the relationship between the term “characteristic” used in this part of ISO 17450 and “characteristic” as it is used in the current GPS standards.



**Figure D.1 — Concept diagram for characteristics**

## Annex E (informative)



### Invariance classes

All surfaces can be classified into seven classes based on the degree of freedom for which corresponding ideal feature is invariant. (A collection of two or more surfaces also belongs to one of these classes.)

**NOTE** The term “invariance degree”, used in geometry, is the correct term for “degree of freedom” used in kinematics. The way in which these terms are used in this part of ISO 17450 is such that the number of invariance degrees is equal to the number of degrees of freedom for a given geometrical feature.

Table E.1 defines the situation features (point, straight line, plane or helix) for each invariance class.

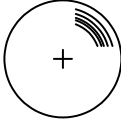
**Table E.1 — Table of invariance classes**

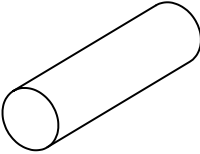
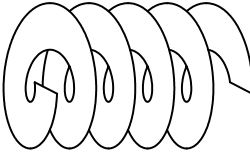
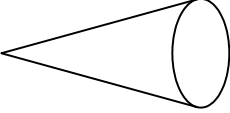
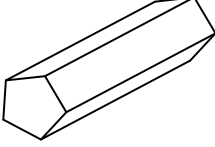
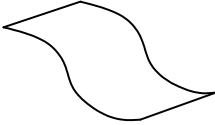
Invariance class	Invariance degrees for which the surface is invariant	Illustration	Situation features	Example of types of surfaces
Spherical	3 rotations around a point		Point	Sphere
Planar	1 rotation perpendicular to the plane and 2 translations along 2 lines of the plane		Plane	Plane
Cylindrical	1 translation and 1 rotation around a straight line		Straight line	Cylinder
Helical	Combination of 1 translation and 1 rotation around a single straight line		Helix	Helical surface with a basis of involute to a circle
Revolute	1 rotation along a straight line		Straight line Point	Cone Torus
Prismatic	1 translation along a line of a plane		Plane Straight line	Prism with an elliptic basis
Complex	None		Plane Straight line Point	Bezier surface based on an unstructured cloud of points in space



**EXAMPLE 1** In the case of a nominal cylindrical surface, this surface is invariant in two directions (1 translation and 1 rotation), so it belongs to the “cylindrical” invariance class (see Table E.1). The situation feature relative to this feature is a straight line (axis of cylinder).

**EXAMPLE 2** In the case of a nominal conical surface, this surface is invariant only in one direction (1 rotation), so it belongs to the “revolute” invariance class (see Table E.1). The situation features relative to this feature are a straight line (axis of a cone) and a point (special point belonging to the axis).

**EXAMPLE 3** In the case of a collection of two nominal cylindrical surfaces, nominally non-coaxial with parallel axes, this collection surface is invariant only in one direction (1 translation), so it belongs to the “prismatic” invariance class (see Table E.1). The situation features relative to this collection feature are a straight line (median line of the two axes of cylinders) and a plane (plane containing the two axes of cylinders).

## Annex F (informative)

### Relationship to the GPS matrix model

#### F.1 General

For full details about the GPS matrix model, see ISO/TR 14638.

The ISO/GPS Masterplan given in ISO/TR 14638 gives an overview of the ISO/GPS system of which this document is a part. The fundamental rules of ISO/GPS given in ISO 8015 apply to this document and the default decision rules given in ISO 14253-1 apply to specifications made in accordance with this document, unless otherwise indicated.

#### F.2 Information about this part of ISO 17450 and its use

This part of ISO 17450 is a basis for future standards covering geometrical specification and verification.

#### F.3 Position in the GPS matrix model

This part of ISO 17450 is a global GPS document that influences all the chain links of the chains of standards, as graphically illustrated in Figure F.1.

Global GPS standards							
<b>Fundamental GPS standards</b>	General GPS standards						
	Chain link number	1	2	3	4	5	6
	Size						
	Distance						
	Radius						
	Angle						
	Form of line independent of datum						
	Form of line dependent on datum						
	Form of surface independent of datum						
	Form of surface dependent on datum						
	Orientation						
	Location						
	Circular run-out						
	Total run-out						
	Datums						
	Roughness profile						
	Waviness profile						
	Primary profile						
	Surface imperfections						
	Edges						

**Figure F.1 — Position in the GPS matrix model**

#### F.4 Related International Standards

The related International Standards are those of the chains of standards indicated in Figure F.1.

© ISO 2011. All rights reserved.

## Bibliography

- [1] ISO 1101:2004, *Geometrical Product Specifications (GPS) — Geometrical tolerancing — Tolerances of form, orientation, location and run-out*
- [2] ISO 8015, *Geometrical product specifications (GPS) — Fundamentals — Concepts, principles and rules*
- [3] ISO 14253-1, *Geometrical Product Specifications (GPS) — Inspection by measurement of workpieces and measuring equipment — Part 1: Decision rules for proving conformance or non-conformance with specifications*
- [4] ISO/TR 14638:1995, *Geometrical product specification (GPS) — Masterplan*
- [5] ISO 17450-2, *Geometrical product specifications (GPS) — General concepts — Part 2: Basic tenets, specifications, operators, uncertainties and ambiguities*
- [6] ISO 22432, *Geometrical product specifications (GPS) — Features utilized in specification and verification*
- [7] BALLU, A. and MATHIEU, L. *Analysis of dimensional and geometrical specifications: standards and models*. CIRP Computer Aided Tolerancing, 3rd Seminar, Cachan, France, 1993, pp. 157-170
- [8] BALLU, A. and MATHIEU, L. *Univocal expression of functional and geometrical tolerances for design, manufacturing and inspection*. CIRP Computer Aided Tolerancing, 4th Seminar, Tokyo, Japan, 1995, pp. 31-46
- [9] BALLU, A. *Identification de modèles géométriques composés pour la spécification et la mesure par coordonnées des caractéristiques fonctionnelles des pièces mécaniques*. Doctoral thesis. LURPA-NANCY 1, 1993
- [10] SRINIVASAN, V. *A Geometrical Product Specification Language Based on a Classification of Symmetry Groups*. Research Report, 1999
- [11] SRINIVASAN, V. *Theory of Dimensioning: An Introduction to Parameterizing Geometric Models*, Marcel-Dekker, New York, 2004
- [12] SRINIVASAN, V. *Mathematical Theory of Dimensioning and Parameterizing Product Geometry*. *International Journal of Product Lifecycle Management*, 1(1), pp. 70-85, 2005

## Alphabetical index

	A		N
associated feature	3.3.8	nature	3.3.1.4
association	3.4.1.4	nominal feature	3.3.3
attribute	3.3.1.1	nominal model	3.2.1
		non-ideal feature	3.3.2
	C	non-ideal surface model	3.2.2
characteristic	3.5		O
collection	3.4.1.5	operation	3.4
construction	3.4.1.6		P
		partition	3.4.1.1
	D		R
derived feature	3.3.6	real feature	3.3.4
deviation	3.8	real surface	3.1
dimensional parameter	3.3.1.1.1	reconstructed feature	3.3.10
		reconstruction	3.4.1.7
	E	reduction	3.4.1.8
evaluation	3.4.2		S
extracted feature	3.3.7	shape	3.3.1.1.4
extraction	3.4.1.2	situation characteristic	3.5.2
		situation characteristic between ideal features	3.5.2.1
	F	situation characteristic between non-ideal and ideal features	3.5.2.2
feature of size	3.3.1.5	situation feature	3.3.1.1.3
feature of angular size	3.3.1.5.2	skeleton feature	3.3.1.1.2
feature of linear size	3.3.1.5.1	skin model	3.2.2
feature of size with linear size	3.3.1.5.1	specification	3.6
feature operation	3.4.1	specification by dimension	3.6.1
filtered feature	3.3.9	specification by zone	3.6.2
filtration	3.4.1.3	surface model	3.2
			T
	G	transformation	3.4.3
geometrical feature	3.3	type	3.3.1.3
			V
	I	variation	3.7
ideal feature	3.3.1	variation curve	3.7.1
integral feature	3.3.5		
intrinsic characteristic	3.5.1		
invariance class	3.3.1.2		

---

---

**ICS 17.040.01**

Price based on 63 pages