**Respiratory protective devices —
Performance requirements —**

**Part 3:
Thread connection**

*Appareils de protection respiratoire — Exigences de performances —
Partie 3: Raccord normalisé*



Reference number
ISO 17420-3:2012(E)

© ISO 2012



COPYRIGHT PROTECTED DOCUMENT

© ISO 2012

All rights reserved. Unless otherwise specified, no part of this publication may be reproduced or utilized in any form or by any means, electronic or mechanical, including photocopying and microfilm, without permission in writing from either ISO at the address below or ISO's member body in the country of the requester.

ISO copyright office
Case postale 56 • CH-1211 Geneva 20
Tel. + 41 22 749 01 11
Fax + 41 22 749 09 47
E-mail copyright@iso.org
Web www.iso.org

Published in Switzerland

Contents

	Page
Foreword	iv
1 Scope	1
2 Normative references	1
3 Terms, definitions and symbols	1
3.1 Terms and definitions	1
3.2 Symbols	1
4 Requirements	2
4.1 Elements of thread connection	2
4.2 Sealing element	2
4.3 Geometry of thread profile	2
4.4 Physical and mechanical requirements of the thread connection	7
5 Testing	8
5.1 Visual inspection	8
5.2 Circularity of threads	8
5.3 Geometry of male thread connector	9
5.4 Geometry of female thread connector	12
5.5 Beginning of the effective thread of the male connection	16
5.6 Resistance of the connectors to pull forces	16
6 Marking and identification	17
Bibliography	18

Foreword

ISO (the International Organization for Standardization) is a worldwide federation of national standards bodies (ISO member bodies). The work of preparing International Standards is normally carried out through ISO technical committees. Each member body interested in a subject for which a technical committee has been established has the right to be represented on that committee. International organizations, governmental and non-governmental, in liaison with ISO, also take part in the work. ISO collaborates closely with the International Electrotechnical Commission (IEC) on all matters of electrotechnical standardization.

International Standards are drafted in accordance with the rules given in the ISO/IEC Directives, Part 2.

The main task of technical committees is to prepare International Standards. Draft International Standards adopted by the technical committees are circulated to the member bodies for voting. Publication as an International Standard requires approval by at least 75 % of the member bodies casting a vote.

Attention is drawn to the possibility that some of the elements of this document may be the subject of patent rights. ISO shall not be held responsible for identifying any or all such patent rights.

ISO 17420-3 was prepared by Technical Committee ISO/TC 94, *Personal safety — Protective clothing and equipment*, Subcommittee SC 15, *Respiratory protective devices*.

ISO 17420 consists of the following parts, under the general title *Respiratory protective devices — Performance requirements*:

— *Part 3: Thread connection*

The following parts are under preparation:

— *Part 1: Supplied breathable gas devices*

— *Part 2: Filtering devices*

.....

Respiratory protective devices — Performance requirements —

Part 3: Thread connection

1 Scope

This part of ISO 17420 is applicable to an unassisted filtering device and specifies a standard thread connection between a filter and the respiratory interface as required in ISO 17420-2.

This part of ISO 17420 also includes the description of test simulators that are necessary for the assessment of some of the requirements.

2 Normative references

The following referenced documents are indispensable for the application of this document. For dated references, only the edition cited applies. For undated references, the latest edition of the referenced document (including any amendments) applies.

ISO 815-1, *Rubber, vulcanized or thermoplastic — Determination of compression set — Part 1: At ambient or elevated temperatures*

ISO 7619-1, *Rubber, vulcanized or thermoplastic — Determination of indentation hardness — Part 1: Durometer method (Shore hardness)*

ISO 16972, *Respiratory protective devices — Terms, definitions, graphical symbols and units of measurement*

3 Terms, definitions and symbols

3.1 Terms and definitions

For the purposes of this document, the terms and definitions given in ISO 16972 and the following apply.

3.1.1

thread connection

shape and dimensions of the standard connection between filters with a male thread connector and respiratory interfaces with a female thread connector

3.2 Symbols

For the purposes of this document, the following symbols apply (see Figure 1 to Figure 20).

d_1	major diameter of male thread;
d_2	minor diameter of male thread;
d_3	inner dimension for gauge;
d_4	outer dimension for gauge;
D_1	major diameter of female thread;

D_2	minor diameter of female thread;
h	pitch;
t_1	thread height;
r	radius;
b	thickness of gauge (GO gauge or NO-GO gauge);
w	permissible surface degradation due to wear and tear for d_1 and d_2 ;
H_a	thickness of ring A;
H_b	thickness of ring B.

4 Requirements

4.1 Elements of thread connection

The thread connection shall consist of the following three elements.

- a) A male thread connector which forms the connecting element of the filter.
- b) A female thread connector which forms the connecting element of the respiratory interface. If a low pressure hose is included in the respiratory interface it shall either be permanently affixed or shall be connected by a non-standard connector.
- c) A sealing element which is retained within the female thread connector.

4.2 Sealing element

The sealing element shall be retained in place, correctly centred, and it shall not be possible to dislodge it during normal use.

It shall be easy to check that the sealing element is in place (e.g. sealing element of a different colour from the female thread connector).

Test in accordance with 5.1.

4.3 Geometry of thread profile

The profile of the thread shall be $\emptyset 40 \times 1/7$ as defined by the female and male threads profile geometry (Figure 1) and thread dimensions given in Table 1.

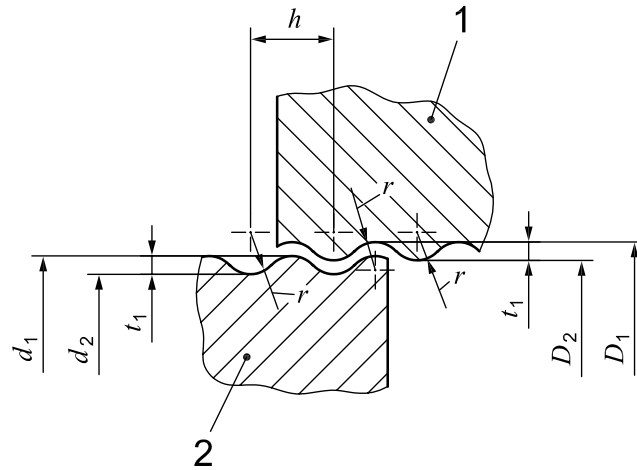

Key

- 1 female thread
- 2 male thread

Figure 1 — Geometry of thread profile

Table 1 — Thread dimensions for the mechanical connection interface

Dimensions in millimetres

Thread	Male thread		Female thread				Pitch	No. of threads per 25,4 mm	Thread height	Radius
	Major diameter	Minor diameter	Major diameter	Minor diameter						
	d_1	d_2	D_1	D_2						
	max.	min.	max.	min.	min.	max.	h	z	t_1	r
Ø 40x1/7	40,00	39,70	38,40	40,16	38,56	38,86	3,629	7	0,8	1,225

Test in accordance with 5.1, 5.3, 5.4 and 5.5.

4.3.1 Circularity of threads

4.3.1.1 General

The circularity tolerance of the threads shall be 0,15 mm referred to the major radius of the male thread and 0,15 mm referred to the minor radius of the female thread.

4.3.1.2 Circularity of the male thread

When approached perpendicular to the axis of the thread in any angular orientation, the limit snap gauge with single-ended jaws shall not pass over the thread (see Figure 7).

Test in accordance with 5.2.1.

4.3.1.3 Circularity of the female thread

When approached parallel to the axis of the thread in any angular orientation, the sector NO-GO gauge shall not enter the thread (see Figure 8).

Test in accordance with 5.2.2.

4.3.2 Male thread connector

4.3.2.1 General

The material used for the male thread connector and its thickness is left to the manufacturer's choice.

4.3.2.2 Sealing surface

The shape of the sealing surface of the male thread connector shown in Figure 2 with the enlarged detail of Figures 2 a, 2 b, 2 c, that interfaces with the sealing element, is left to the manufacturer's choice. For example, it can be flat (see Figure 2 a), rounded with a radius ≥ 2 mm (see Figure 2 b) or flat with a raised sealing ring (see Figure 2 c). If there is a raised sealing ring, it shall have a radius $\geq 0,3$ mm.

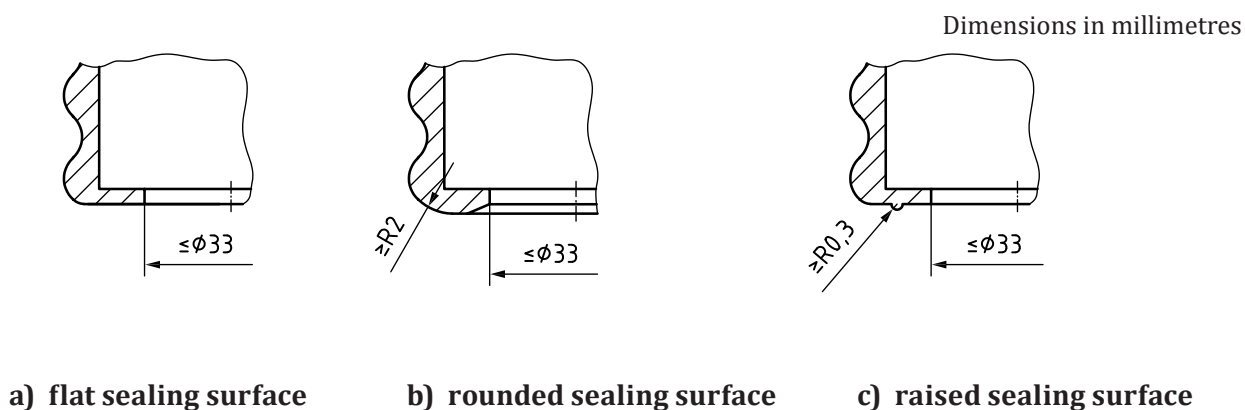

Figure 2 — Sealing surface of the male thread connector

4.3.2.3 Dimensions

The axial dimensions of the male thread connector shall be measured starting from the most protruding part of the sealing surface (including raised sealing ring, if present).

The beginning of the thread, up to a maximum of 2 mm of length, is not considered as effective thread and it shall be left to the manufacturer's design choice. The initiation of the thread shall be smooth.

When the GO gauge is screwed by hand without excessive force onto the male thread connector, at least 2 mm of the connector shall extend from the surface of the gauge.

The effective length of thread shall be $\geq 14,5$ mm (see Figure 3).

When gauged with the effective length ring gauge, the distance from the top of the gauge to the top of the thread shall be ≥ 8 mm (see Figure 19 and 20).

The internal diameter (minimum diameter of the sealing surface area) of the male thread connector shall be $\leq 33,0$ mm (see Figure 2).

It shall not be possible to fit the NO-GO gauge onto the male thread connector.

Without excessive force, the NO-GO gauge shall bind after initial engagement.

Test in accordance with 5.1, 5.3 and 5.5.

Dimensions in millimetres

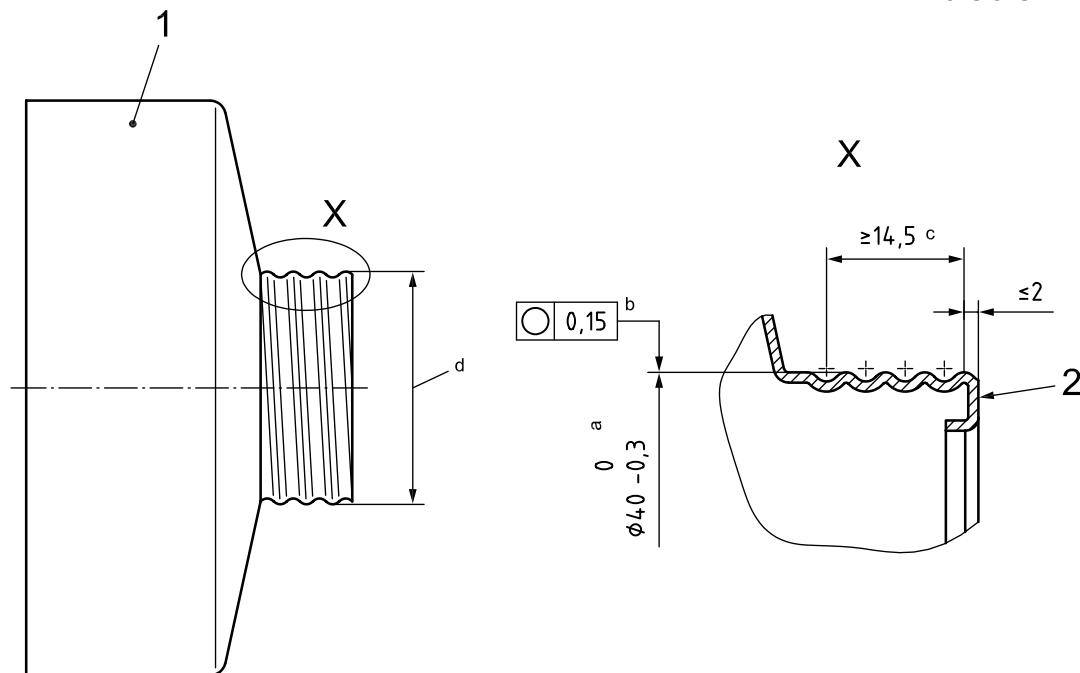
**Key**

- 1 filter
2 sealing surface

- a Major diameter.
b Reference to radius.
c Effective thread.
d Thread $\text{\O}40 \text{ mm} \times 1/7''$.

Figure 3 — Male thread connector**4.3.3 Female thread connector****4.3.3.1 General**

The material used for the female thread connector and its thickness is left to the manufacturer's choice.

4.3.3.2 Dimensions

The axial dimensions of the female thread connector shall be measured starting from the sealing surface of the sealing element.

The available length of the thread of the female thread connector shall be $(13,0 \pm 0,5)$ mm extended to the edge of the connector (see Figure 4).

When the GO side of the gauge, with ring A in place, is screwed by hand without excessive force into the female thread connector (with the sealing element correctly in place), ring A shall block.

When the GO side of the gauge, with ring B in place, is screwed by hand without excessive force into the female thread connector (with the sealing element correctly in place), ring B shall remain loose.

The internal diameter of the female thread connector (minimum diameter of the sealing area) shall be ≤ 30 mm (see Figure 4).

ISO 17420-3:2012(E)

It shall not be possible to fit the NO-GO side of the gauge into the female thread connector without excessive force. It shall bind after initial engagement.

If the central hole of the connector on the respiratory interface has a rim for retention and centring of the sealing element, it shall end at least 1 mm below the surface of the sealing element interfacing the filter.

The part of the female thread connector below the level of the upper surface of the sealing element shall not invade the surface defined by the extension of the thread towards the lower surface of the sealing element (see enlarged detail of Figure 4).

Test in accordance with 5.1 and 5.4.

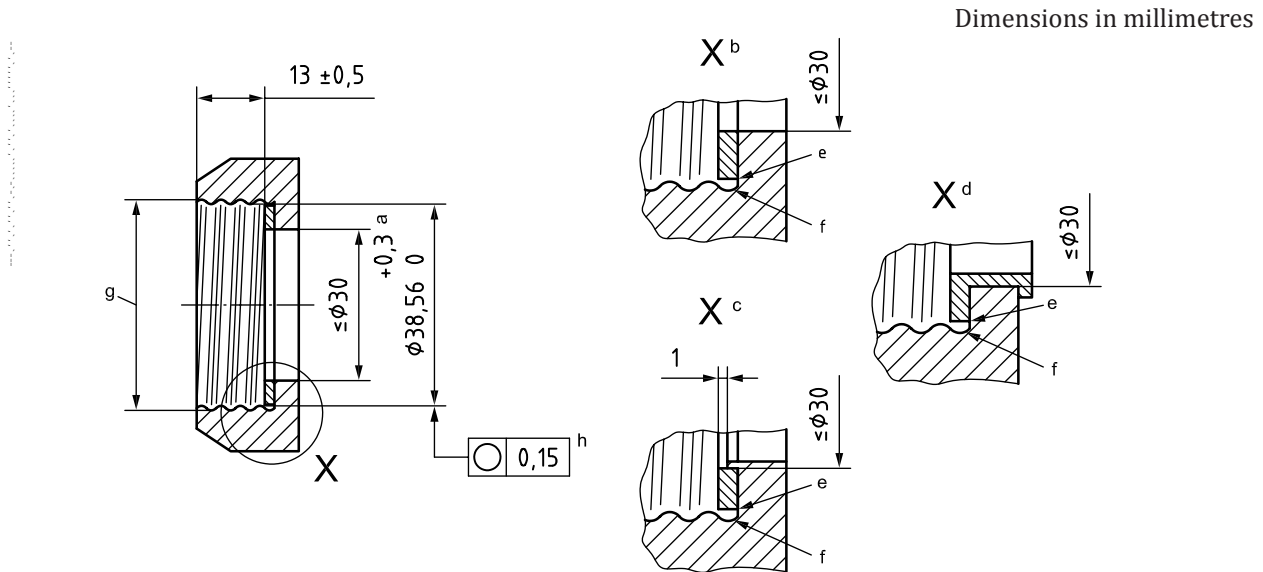

- a Minor diameter.
- b Example A.
- c Example B.
- d Example C.
- e The external diameter of the sealing element shall be $\geq 37,5$ mm.
- f The female thread connector shall not invade beyond the line.
- g Thread $\phi 40$ mm x $1/7''$.
- h Reference to radius.

Figure 4 — Female thread connector

4.3.4 Sealing element

The sealing element shall be annular with a flat surface towards the filter.

The external diameter of the sealing element shall be $\geq 37,5$ mm.

The internal diameter of the sealing element shall be $\leq 30,0$ mm.

Its thickness shall be $(2,0 + 0,5)$ mm.

Test in accordance with 5.1.

4.3.5 Absence of geometric interference

The back face of the filter shall not protrude beyond the plane perpendicular to the axis of the filter, passing at the end of the effective length of the thread in a circular area of at least $63,5$ mm of radius.

Dimensions in millimetres

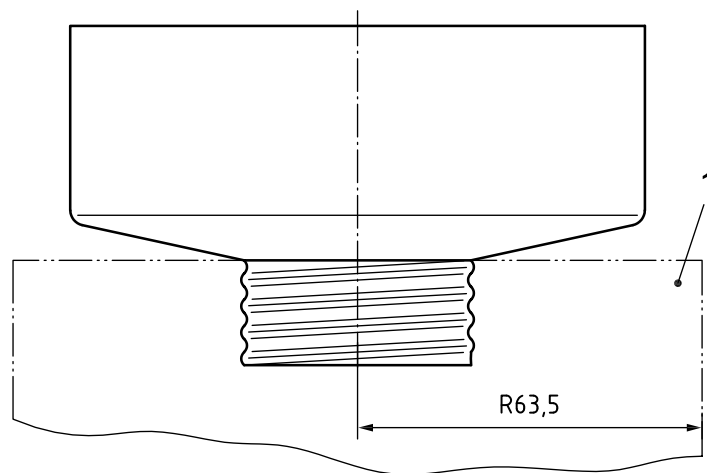
**Key**

1 area, which shall not be invaded by the filter body

Figure 5 — Absence of geometric interference of the filter body

The front face of the female thread connector of the respiratory interface shall not protrude beyond the plane perpendicular to the axis of the female thread connector, passing at the end of the effective length of the connector in a circular area of at least 63,5 mm of radius.

Test in accordance with 5.1, 5.3 and 5.4.

Dimensions in millimetres

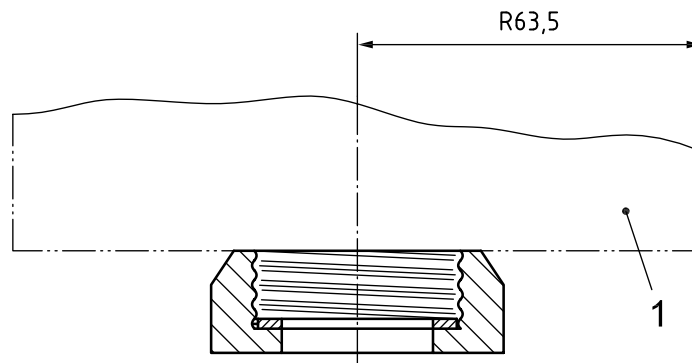
**Key**

1 area, which shall not be invaded by the female thread connector and the respiratory interface

Figure 6 — Absence of geometric interference of the female thread connector

4.4 Physical and mechanical requirements of the thread connection

4.4.1 Resistance of the connectors to pull forces

The male and the female thread connectors shall withstand an axial pull force of 100 N for 10 s.

No connection shall separate, break or be permanently deformed as a result of the applied forces.

Permanent deformation shall be assessed with the gauges in accordance with Figure 7, Figure 8 and Figure 10.

Test in accordance with 5.6.

4.4.2 Physical and mechanical requirements of the sealing element

4.4.2.1 Hardness

The hardness of the material used for the sealing element shall be between 55 Shore A and 70 Shore A when measured on standard samples of the material used for the sealing element.

Test in accordance with ISO 7619-1.

4.4.2.2 Compression set

Compression set after 22 h at 68 °C shall be not greater than 25 %.

Test in accordance with ISO 815-1.

5 Testing

5.1 Visual inspection

Where no specific test method is presented for making measurements on the connection, measurements shall be made using standard laboratory methods.

The gauges described can be used to assess the geometric requirements of the connector. Alternative methods, e.g. optical methods, may be used.

All samples are subject to visual inspection as specified within this International Standard.

5.2 Circularity of threads

5.2.1 Circularity of male threads

With the limit snap gauge with single-ended jaws (shown in Figure 7) perpendicular to the axis of the thread at all times, attempt to pass the gauge over the thread in at least three different angular orientations to check the circularity of the thread.

Record the results.

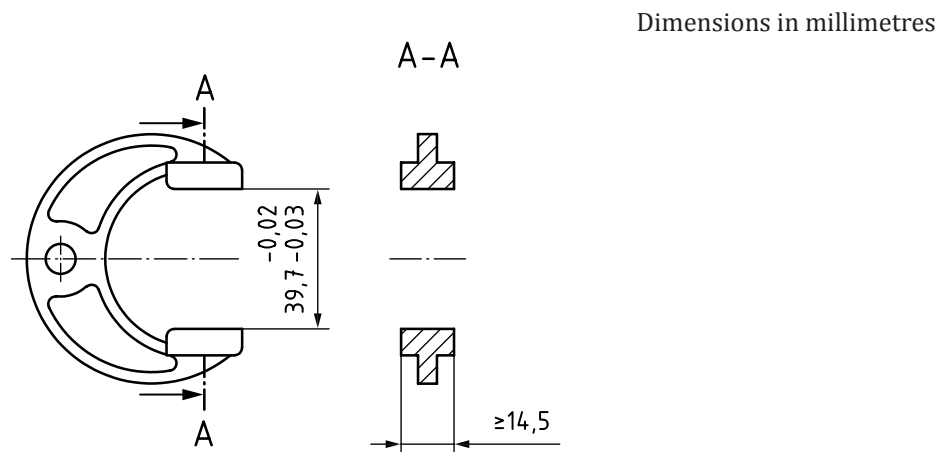

Figure 7 — Limit snap gauge with single-ended jaws

5.2.2 Circularity of female threads

With the sector NO-GO gauge (shown in Figure 8) parallel to the axis of the thread at all times, attempt to pass the gauge into the thread in at least three different angular orientations to check the circularity of the thread.

Record the results.

Dimensions in millimetres

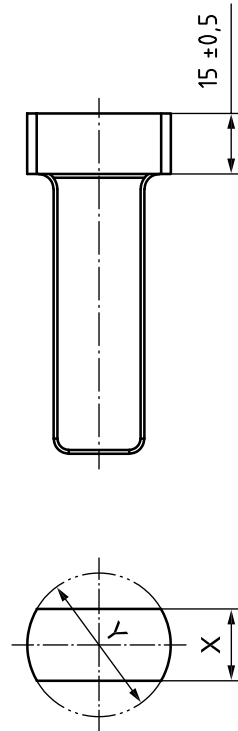

Key

$Y = 38,96 \text{ mm } (+0,04; +0,02) \text{ mm}$

$X = 1/2 \text{ of } Y$

Figure 8 — Sector NO-GO gauge

5.3 Geometry of male thread connector

Absence of physical interference and the shape and dimensions of the thread and length of the male thread connector are checked with the GO gauge (Table 2, Figure 10) and the NO-GO gauge (Table 3, Figure 11).

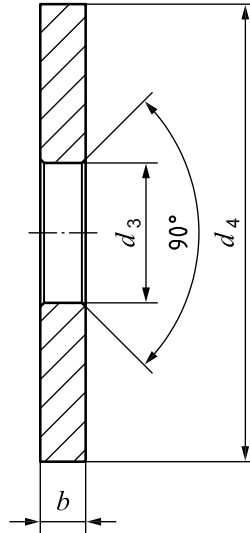

Figure 11 — NO-GO gauge

Without using excessive force, screw the GO gauge onto the male thread connector, check for physical interference and measure the length of the thread protruding from the surface of the gauge as shown in Figure 12.

Record the results.

Try to insert the male thread connector into the NO-GO gauge without excessive force. It shall not be possible to extend it into the NO-GO gauge by more than 6 mm, measured from the back of the gauge as shown in Figure 13.

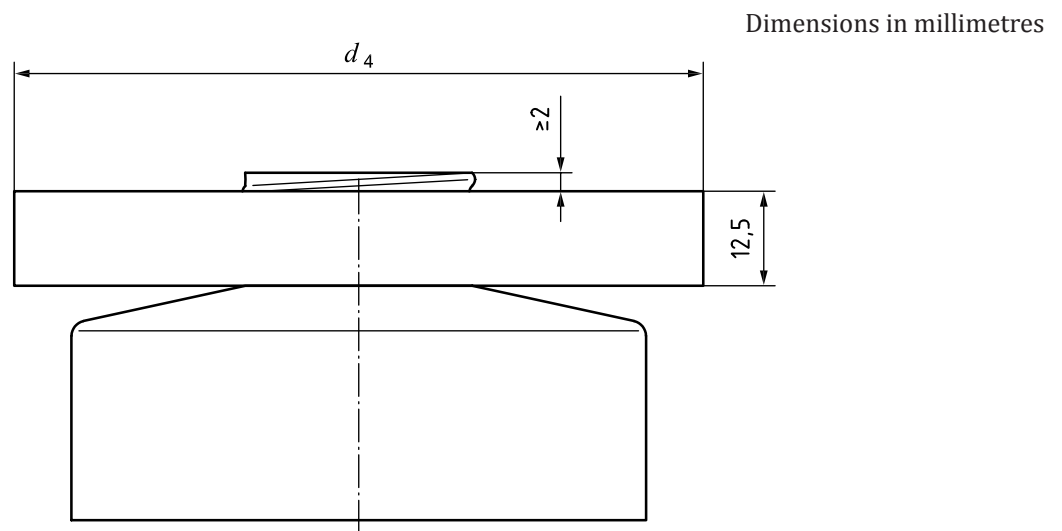

Figure 12 — Measurement of protruding thread

Dimensions in millimetres

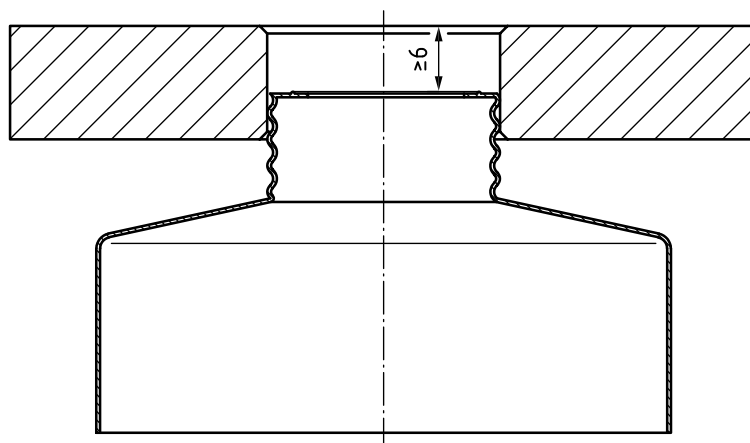
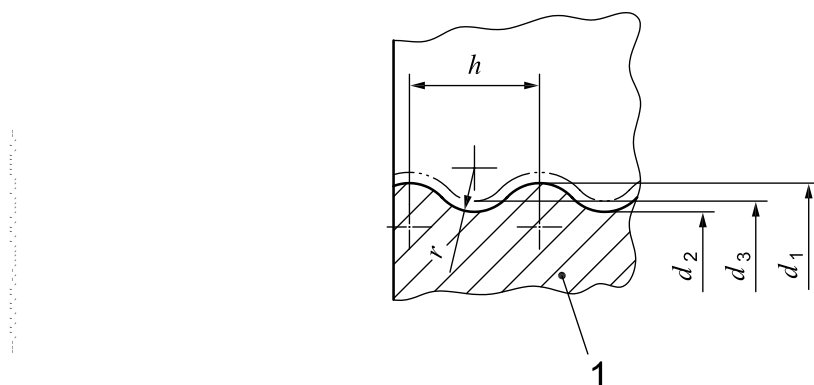

Figure 13 — Measurement of extension into NO-GO gauge

5.4 Geometry of female thread connector

Absence of physical interference and the shape and dimensions of the thread and depth of the female thread connector are checked with the GO gauge (see Table 4, Figure 14, Figure 15 and Figure 16) and the NO-GO gauge (see Table 5, Figure 17 and Figure 18).



Key

1 plug gauge

Figure 14 — Profile of female thread connector

Table 4 — Dimensions of GO gauge for female thread connector

Dimensions in millimetres

Thread	GO gauge								
	d_1	tol.	d_2	tol.	w	h	tol.	r	l_1
	min.		min.						
Ø 40x1/7	40,16	-0,02 -0,04	38,56	-0,02 -0,04	-0,050	3,629	±0,009	1,225	14

Table 5 — Dimensions of NO-GO gauge for female thread connector

Dimensions in millimetres

Thread	NO-GO gauge			Ring A		Ring B		d_4	tol.
	d_3	tol.	l_2	H_a	tol.	H_b	tol.		
$\varnothing 40 \times 1/7$	38,86	+0,02 +0,04	10	3,5	+0,02 0	2,5	-0,05 -0,15	127	+0,5 0

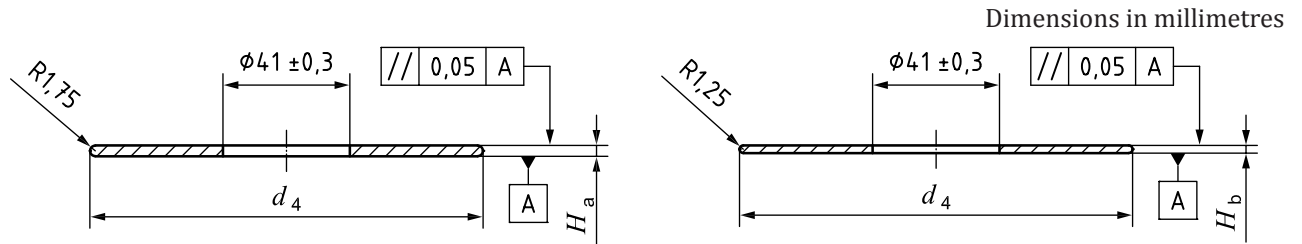

a) ring A

b) ring B

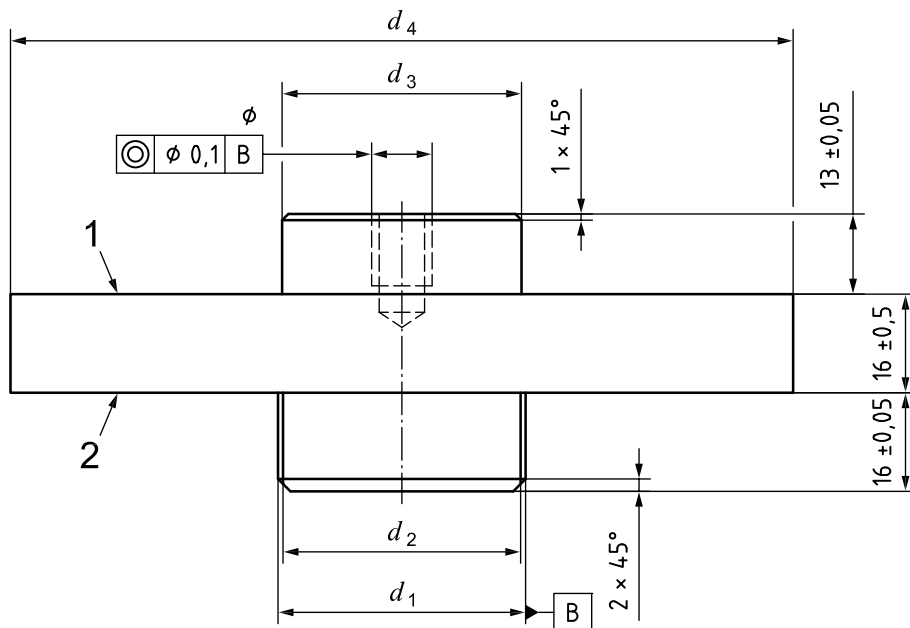

Key

- 1 NO-GO side
- 2 GO side

Figure 15 — Gauge dimensions for check of female thread connector

Dimension d_3 for the NO-GO side of the gauge in Figure 15 is to be taken from Table 5.

Without using excessive force, screw the GO side of the gauge fitted with ring A into the female thread connector (with the sealing element correctly in place) as shown in Figure 16.

Check for any physical interference and record the results.

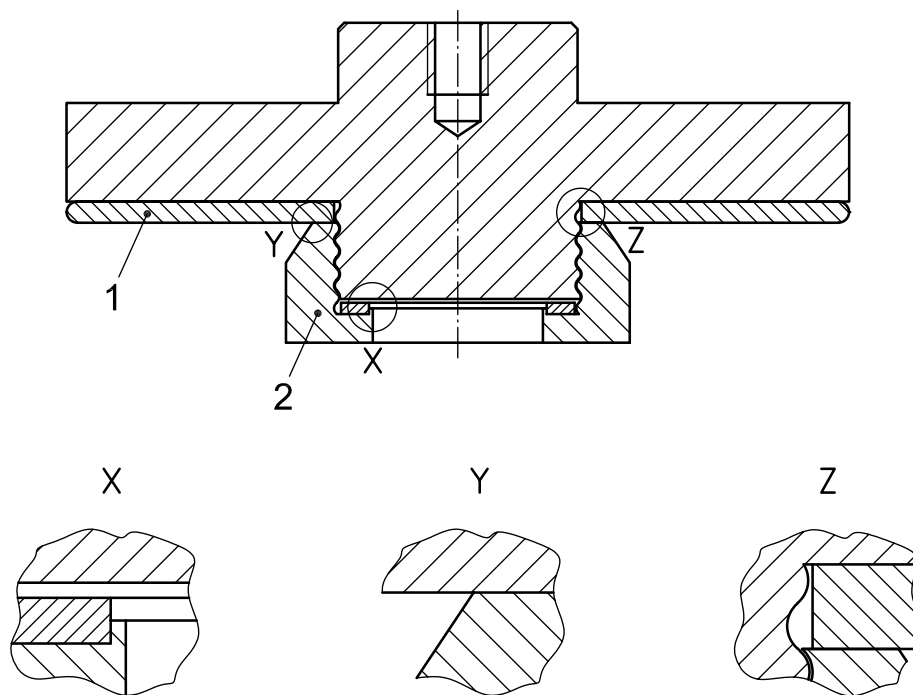

Key

- 1 ring A
- 2 female thread connector

Figure 16 — Application of ring A

Without using excessive force, screw the GO side of the gauge fitted with ring B into the female thread connector (with the sealing element correctly in place) as shown in Figure 17.

Check for any physical interference and record the results.

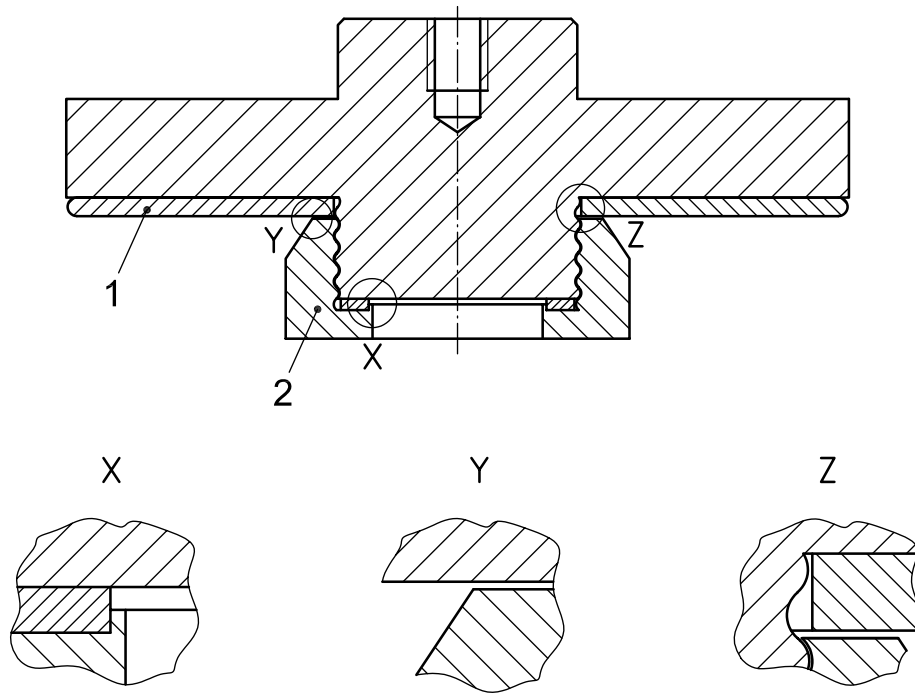

Key

- 1 ring B
- 2 female thread connector

Figure 17 — Application of ring B

It shall not be possible to insert the NO-GO gauge into the female thread connector by more than 6 mm without excessive force as shown in Figure 18.

Record the results.

Dimensions in millimetres

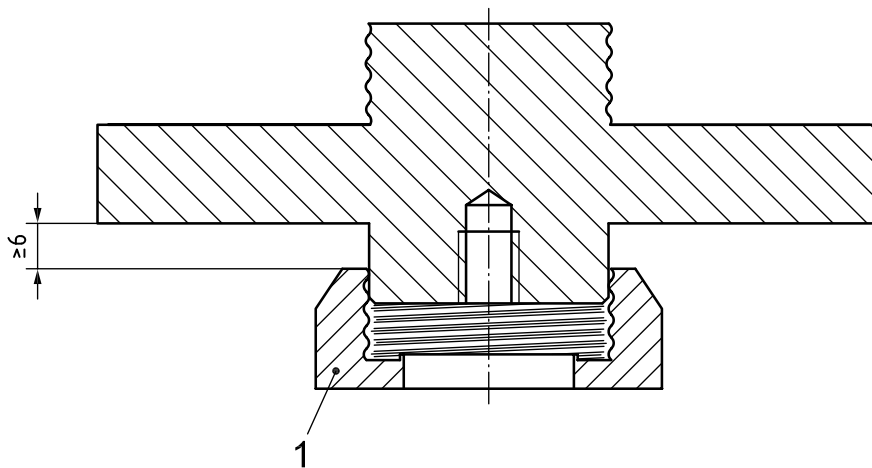

Key

- 1 female thread connector

Figure 18 — Measurement of insertion of NO-GO gauge

5.5 Beginning of the effective thread of the male connection

With the thread of the male thread connector placed vertically upwards in a stable position, fit the effective length ring gauge (as shown in Figure 19 and Figure 20) onto the thread (as shown in Figure 20) and allow it to settle under the action of its own mass. Measure and record the distance between the top of the gauge and the top of the threads.

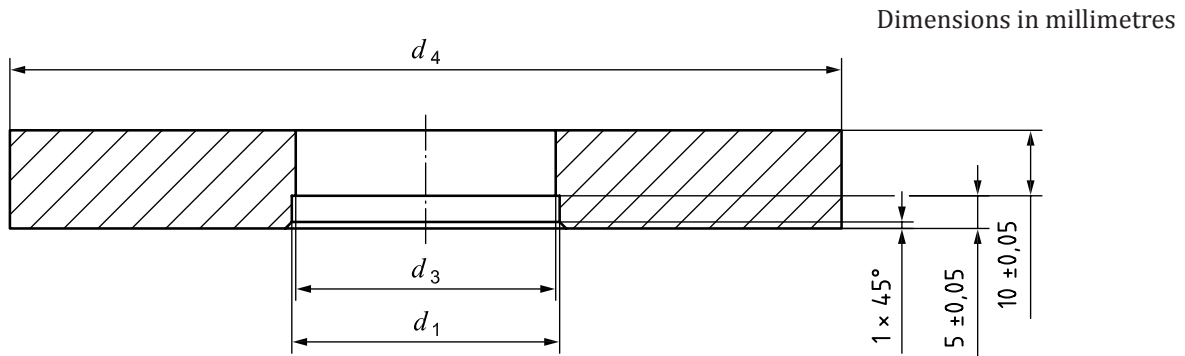

Figure 19 — Effective length ring gauge

Dimension d_1 , and relative tolerances, are to be taken from Tables 4 and 5.

Dimension d_3 , and relative tolerances, are to be taken from Tables 2 and 3.

Dimension d_4 , and relative tolerances, are to be taken from Tables 4 and 5.

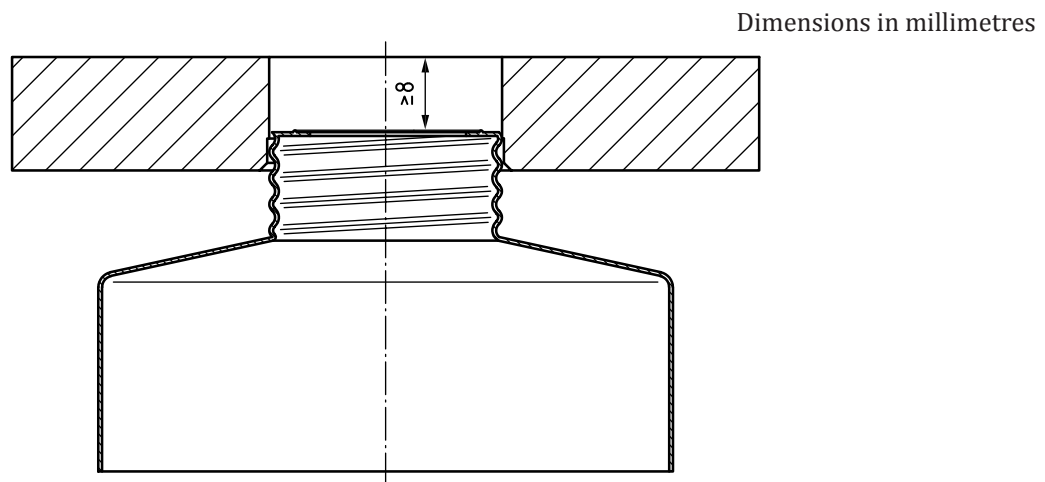

Figure 20 — Fitting of effective length ring gauge

5.6 Resistance of the connectors to pull forces

Testing of the male thread connector shall be done using the GO gauge in accordance with Figure 10 where two threaded hooks and a wire are added to suspend the additional mass which, when added progressively, produces a total force of 100 N.

Testing of the female thread connector shall be done using the GO/NO-GO gauge in accordance with Figure 15 (without ring A or ring B), where a threaded hook is added to suspend the additional mass which, when added progressively, produces a total force of 100 N.

Both tests shall be done with the axis of the connectors orientated vertically.

6 Marking and identification

Filters with a male thread connector in accordance with this part of ISO 17420 shall be marked as described in ISO 17420-2.

Respiratory interfaces with a female thread connector in accordance with this part of ISO 17420 shall be marked as described in ISO 17420-2.

Bibliography

- [1] ISO 17420-2, *Respiratory protective devices — Performance requirements — Part 2: Filtering devices*¹⁾

1) Under preparation.

ICS 13.340.30

Price based on 18 pages