

INTERNATIONAL
STANDARD

ISO
17396

First edition
2014-01-15

**Synchronous belt drives — Metric
pitch, trapezoidal profile systems T
and AT, belts and pulleys**

*Transmissions synchrones par courroies — Pas métrique, poulies et
courroies dentées à dents trapézoïdales de profil T ou AT*



Reference number
ISO 17396:2014(E)

© ISO 2014



COPYRIGHT PROTECTED DOCUMENT

© ISO 2014

All rights reserved. Unless otherwise specified, no part of this publication may be reproduced or utilized otherwise in any form or by any means, electronic or mechanical, including photocopying, or posting on the internet or an intranet, without prior written permission. Permission can be requested from either ISO at the address below or ISO's member body in the country of the requester.

ISO copyright office
Case postale 56 • CH-1211 Geneva 20
Tel. + 41 22 749 01 11
Fax + 41 22 749 09 47
E-mail copyright@iso.org
Web www.iso.org

Published in Switzerland

Contents

	Page
Foreword	iv
1 Scope	1
2 Normative references	1
3 Belt profile systems	1
4 Belt nomenclature	2
5 Pulley profile systems	2
6 Pulley nomenclature	2
7 Belt profile systems T and AT	3
7.1 Belt profile systems T and AT — General	3
7.2 Profile system T — Belt tooth dimensions and tolerances	3
7.3 Profile system AT — Belt tooth dimensions and tolerances	4
8 Belt widths and tolerances	4
9 Pitch length measurement	5
9.1 Endless belts manufactured in circular moulds	5
9.2 For very long endless belts and open belts	6
9.3 Total measuring forces	7
9.4 Procedures	7
9.5 Belt length tolerances	8
10 Pulleys	9
10.1 General profile system T	9
10.2 General profile system AT	12
Annex A (normative) Pulley tolerances	15
Bibliography	18

Foreword

ISO (the International Organization for Standardization) is a worldwide federation of national standards bodies (ISO member bodies). The work of preparing International Standards is normally carried out through ISO technical committees. Each member body interested in a subject for which a technical committee has been established has the right to be represented on that committee. International organizations, governmental and non-governmental, in liaison with ISO, also take part in the work. ISO collaborates closely with the International Electrotechnical Commission (IEC) on all matters of electrotechnical standardization.

The procedures used to develop this document and those intended for its further maintenance are described in the ISO/IEC Directives, Part 1. In particular the different approval criteria needed for the different types of ISO documents should be noted. This document was drafted in accordance with the editorial rules of the ISO/IEC Directives, Part 2 (see www.iso.org/directives).

Attention is drawn to the possibility that some of the elements of this document may be the subject of patent rights. ISO shall not be held responsible for identifying any or all such patent rights. Details of any patent rights identified during the development of the document will be in the Introduction and/or on the ISO list of patent declarations received (see www.iso.org/patents).

Any trade name used in this document is information given for the convenience of users and does not constitute an endorsement.

For an explanation on the meaning of ISO specific terms and expressions related to conformity assessment, as well as information about ISO's adherence to the WTO principles in the Technical Barriers to Trade (TBT) see the following URL: Foreword - Supplementary information

The committee responsible for this document is ISO/TC 41, *Pulleys and belts (including veebelts)*, Subcommittee SC 4, *Synchronous belt drives*.

Synchronous belt drives — Metric pitch, trapezoidal profile systems T and AT, belts and pulleys

1 Scope

This International Standard specifies the principal characteristics of synchronous endless and open belts and pulleys of the profile systems T and AT for use in synchronous belt drives¹⁾ for mechanical power transmission and where positive indexing or synchronization can be required.

The principal belt and pulley characteristics include

- a) nominal belt tooth dimensions,
- b) belt tooth pitch spacing,
- c) belt length and width dimensions,
- d) belt length measurement specifications,
- e) pulley groove dimensions and tolerances,
- f) pulley diameter and width dimensions and tolerances, and
- g) pulley quality specification.

The belts of the profile systems T and AT are made of polyurethane with high-tension fine steel cord tension members in most cases. As far as certain forces are given in this International Standard, these values are only valid for this kinds of belt. For polyurethane belts with different tensile cords, i.e. aramid or rubber belts reinforced with glass fibre, the values can be different. It is intended that the user and the manufacturer agree about suitable values. Open belts made of thermoplastic polyurethane can be spliced to work as endless belts in conveyor applications. In this case, the tolerances are not valid for the splicing area of the endless spliced belt.

2 Normative references

The following documents, in whole or in part, are normatively referenced in this document and are indispensable for its application. For dated references, only the edition cited applies. For undated references, the latest edition of the referenced document (including any amendments) applies.

ISO 254, *Belt drives — Pulleys — Quality, finish and balance*

3 Belt profile systems

Eight belt profiles for synchronous drives are standardized.

Profile system T:	Profile system AT:
— profile T2,5	— profile AT3
— profile T5	— profile AT5
— profile T10	— profile AT10

1) Synchronous belt drives have been known by various titles in the past: for example, timing belt drives, positive belt drives, gear belt drives.

- profile T20
- profile AT20

4 Belt nomenclature

A belt is designated by a combination of numbers and letters as follows:

- a) the width, in millimetres;
- b) the profile system;
- c) the pitch, in millimetres;
- d) the belt pitch length, in millimetres (and add the number of teeth in brackets, if required);
- e) double-sided belts are designated by adding D_G or D_T before the profile system letter: D_G if the tooth position is opposite **Gap**; D_T if the tooth position is opposite **Tooth**;
- f) open belts are designated by adding the letter “M” behind the length; for spliced belts, use the letter “V.”

EXAMPLE 1 A metric synchronous belt of 10 mm pitch, profile system T, 50 mm wide, and 1 400 mm in pitch length is designated as:

- for a single-sided belt: **50 - T10 - 1 400**
- for a double-sided belt : **50 - D_G - T10 - 1 400** or **50 - D_T - T10 - 1 400**

EXAMPLE 2 A metric synchronous belt of 5 mm pitch, profile system AT, 25 mm wide, and 500 mm in pitch length (number of teeth = 100) is designated as:

- for a single-sided belt: **25 - AT5 - 500 (100 t)**
- for double-sided belt: **25 - D_G - AT5 - 500 (100 t)** or **25 - D_T - AT5 - 500 (100 t)**

EXAMPLE 3 An open metric synchronous belt of 5 mm pitch, profile system AT, 25 mm wide, and 50000 mm in pitch length is designated as:

25 - AT5 - 50000 - M

5 Pulley profile systems

Eight pulley profiles for synchronous drives are standardized:

- | Profile system T: | Profile system AT: |
|-------------------|--------------------|
| — profile T2,5 | — profile AT3 |
| — profile T5 | — profile AT5 |
| — profile T10 | — profile AT10 |
| — profile T20 | — profile AT20 |

6 Pulley nomenclature

A pulley for a synchronous drive is identified by the number of grooves, the groove pitch and profile, and the width. It is designated, as is the belt, by a combination of numbers and letters as follows:

- a) the letter “P,” which indicates a pulley;
- b) the number of grooves;

- c) the profile system;
- d) the groove pitch, in millimetres;
- e) the width, in millimetres.

EXAMPLE A pulley for a metric toothed belt which has 20 mm pitch and 30 grooves with a nominal width of 50 mm is identified as follows.

- for T-profile system pulley: **P30 - T20 - 50**
- for AT-profile system pulley: **P30 - AT20 - 50**

7 Belt profile systems T and AT

7.1 Belt profile systems T and AT — General

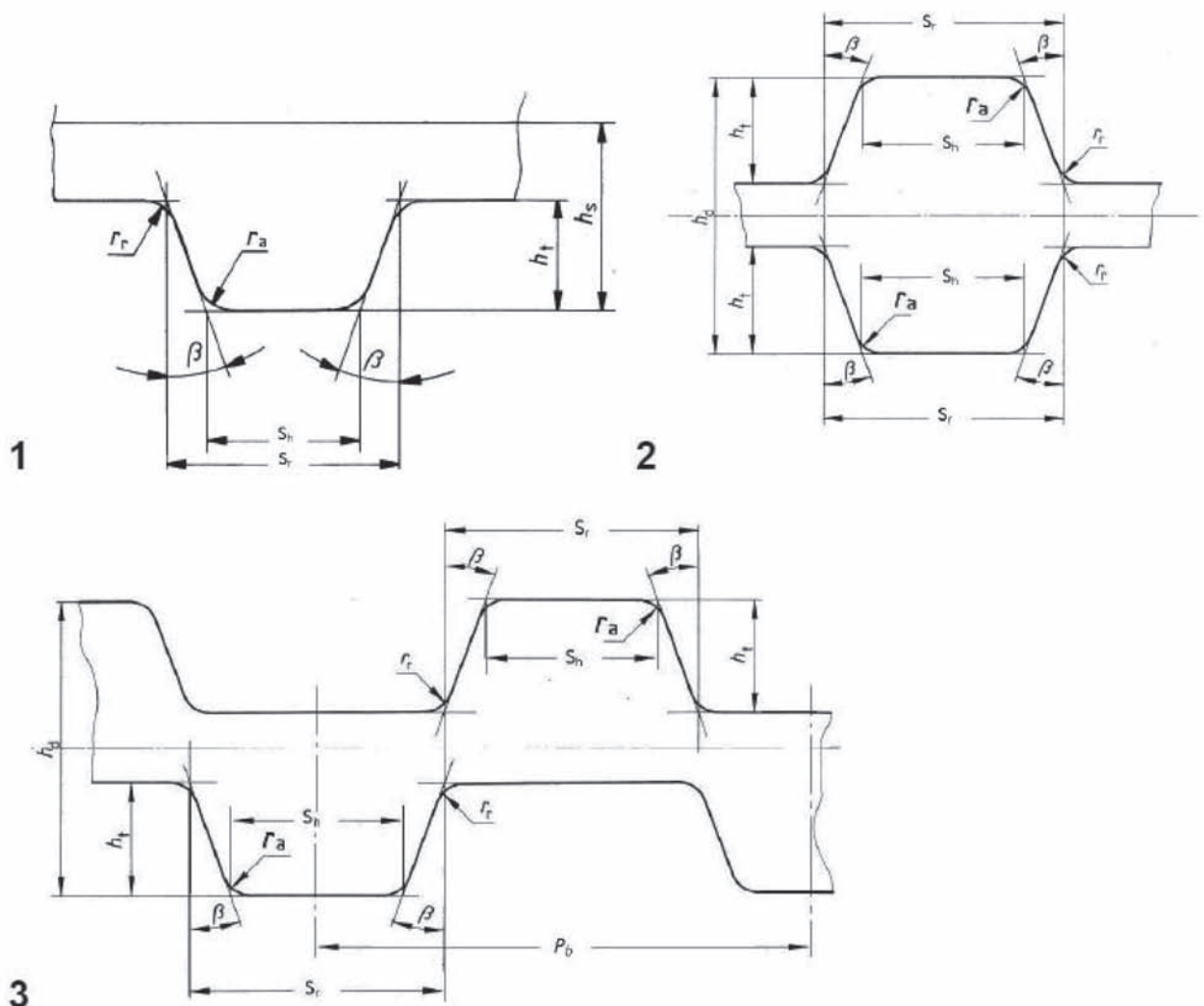

Figure 1 — Belt dimensions for profile systems T and AT

7.2 Profile system T — Belt tooth dimensions and tolerances

The nominal belt tooth dimensions are the same for single-sided and double-sided belts; they are given in [Table 1](#) and shown in [Figure 1](#).

Table 1 — Profile system T — Nominal tooth dimensions

Belt profile	Pitch P_b mm	Tooth angle $2\beta^\circ$	Root width S_r mm	h_s mm	h_d mm	h_t mm	r_a min mm	r_r $\pm 0,1$ mm
T2,5	2,5	40 ± 2	$1,50 \pm 0,05$	$1,30 \pm 0,15$	1,90	$0,70 \pm 0,05$	0,2	0,2
T5	5,0	40 ± 2	$2,65 \pm 0,05$	$2,20 \pm 0,15$	3,25	$1,20 \pm 0,05$	0,4	0,4
T10	10,0	40 ± 2	$5,30 \pm 0,10$	$4,50 \pm 0,30$	6,80	$2,50 \pm 0,10$	0,6	0,6
T20	20,0	40 ± 2	$10,15 \pm 0,15$	$8,00 \pm 0,45$	12,85	$5,00 \pm 0,15$	0,8	0,8

NOTE The value of h_d can vary due to process-related adjustments of the manufacturer.

7.3 Profile system AT — Belt tooth dimensions and tolerances

The nominal belt tooth dimensions are the same for single-sided and double-sided belts; they are given in [Table 2](#) and shown in [Figure 1](#).

Table 2 — Profile system AT — Nominal tooth dimensions

Belt profile	Pitch P_b mm	Tooth angle $2\beta^\circ$	Head width S_h mm	h_s mm	h_d mm	h_t mm	r_a min mm	r_r $\pm 0,1$ mm
AT3	3,0	50 ± 2	$1,50 \pm 0,05$	$1,90 \pm 0,15$	n.a.	$1,10 \pm 0,05$	0,3	0,1
AT5	5,0	50 ± 2	$2,50 \pm 0,05$	$2,70 \pm 0,15$	3,05	$1,20 \pm 0,05$	0,4	0,6
AT10	10,0	50 ± 2	$5,00 \pm 0,10$	$4,50 \pm 0,30^a$ (5,0)	6,50	$2,50 \pm 0,10$	0,6	1,2
AT20	20,0	50 ± 2	$10,00 \pm 0,15$	$8,00 \pm 0,45^a$ (9,0)	12,15	$5,00 \pm 0,15$	1,6	2,5

NOTE The value of h_d can vary due to process-related adjustments of the manufacturer.

^a The thickness of the backside depends on the method of manufacturing.

8 Belt widths and tolerances

Belt widths and tolerances are given in [Table 3](#).

Table 3 — Belt widths and width tolerances

Dimensions in millimetres

Belt profile	Nominal belt width				Tolerance
T2,5	-	4	6	10	$\pm 0,3$
T5	6	10	16	25	$\pm 0,5$
T10	16	25	32	50	$\pm 0,5$
T20	32	50	75	100	$\pm 1,0$
AT3	6	10	16	25	$\pm 0,3$
AT5	6	10	16	25	$\pm 0,5$
AT10	16	25	32	50	$\pm 0,5$
AT20	32	50	75	100	$\pm 1,0$

NOTE Tolerances for larger belt widths and closer tolerances to be confirmed between the user and the manufacturer.

9 Pitch length measurement

9.1 Endless belts manufactured in circular moulds

9.1.1 Measuring fixture (see Figure 2)

The pitch length of a synchronous belt shall be determined by placing the belt on a measuring fixture composed of the following elements.

9.1.1.1 Two pulleys of equal diameter, as specified in Table 4, of the proper profile shown in Table 7. One pulley shall be free to rotate on a fixed-position shaft, while the other shall be free to rotate on a moveable shaft to permit the centre distance to change.

9.1.1.2 Means of applying a total measuring force, to the moveable pulley, as given in Table 5.

9.1.1.3 Means of measuring the centre distance between the two pulleys with the necessary degree of accuracy for centre distance measurement.

NOTE The number of pulley teeth specified in Table 4 determines the recommended sizes for measuring the belt pitch length. Practicably, the other sizes of pulleys can be used provided they have the same number of teeth and meet the dimensional requirements of Table 4.

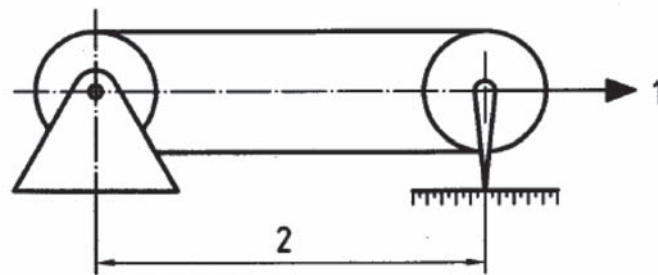

Key

- 1 total measuring force
- 2 centre distance

Figure 2 — Fixture for measuring the pitch length for endless belts manufactured in circular moulds

Table 4 — Belt length measuring pulleys

Dimensions in millimetres

Belt profile	Number of grooves	Pitch circumference	Outside diameter ^a	Radial runout	Axial runout
				FIM ^a	FIM ^a
T2,5	20	50	15,42 -0,05	0,013	0,025
T5	20	100	30,99 -0,05	0,013	0,025
T10	20	200	61,80 -0,08	0,013	0,025
T20	20	400	124,47 -0,08	0,013	0,050
AT3	20	60	18,69 -0,05	0,013	0,025
AT5	20	100	30,61 -0,05	0,013	0,025
AT10	24	240	74,57 -0,08	0,013	0,025
AT20	25	500	156,33 -0,08	0,013	0,050

^a Full indicator movement.

9.2 For very long endless belts and open belts

9.2.1 Measuring fixture (see [Figure 3](#))

The pitch length of a synchronous belt shall be determined by placing the belt on a measuring fixture composed of the following elements.

9.2.1.1 Two identical toothed clamps, of the proper profile, covering three complete belt teeth in mesh, and having zero spacing tooth shape.

9.2.1.2 Means of applying a total measuring force to the moveable clamp, given in [Table 5](#).

9.2.1.3 Means of measuring the distance between the two clamps with the necessary degree of accuracy for distance measurement.

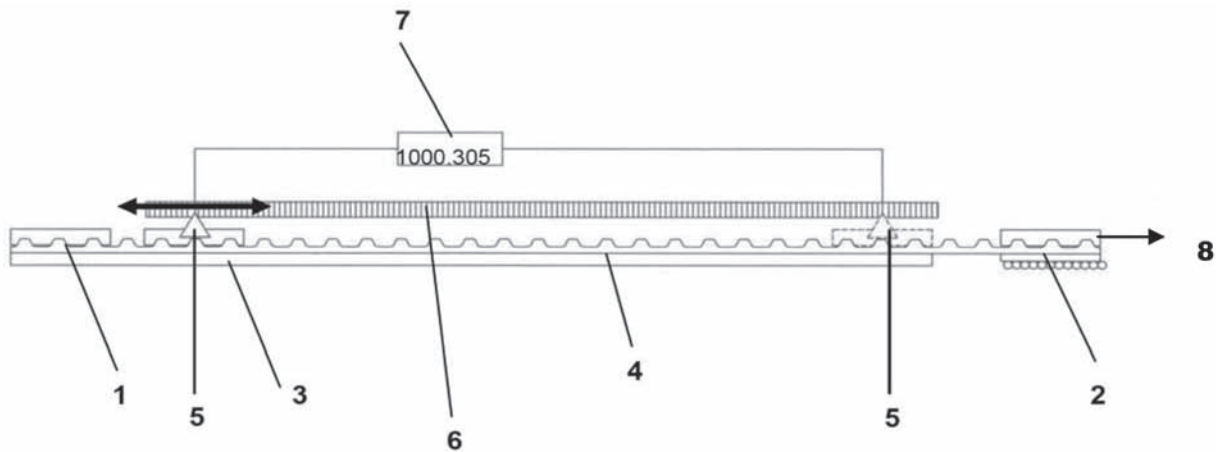

Key

- 1 fixed clamp
- 2 moveable clamp
- 3 table
- 4 belt specimen
- 5 measuring plate
- 6 scale
- 7 display
- 8 total measuring force

Figure 3 — Fixture for measuring pitch length of very long endless belts and open belts

9.3 Total measuring forces

The total measuring force to be applied for measuring belts is given in [Table 5](#).

Table 5 — Total measuring force

Forces in newton

Belt profile	Total measuring force N								
	Belt width mm								
	4	6	10	16	25	32	50	75	100
T2,5	6	10	20						
T5		20	40	60	90	(120)			
T10				90	140	170	270	(410)	(540)
T20					(270)	340	540	800	1100
AT3		20	40	60	90				
AT5		25	50	80	120	(160)	(250)		
AT10			(110)	170	270	340	540	(800)	(1100)
AT20					(650)	860	1300	1950	2600

The given measuring forces are valid for the measurement according to [9.4.1](#); for [9.4.2](#), the measuring forces have to be bisected (50 % of given values). Forces for bigger belt width shall be confirmed between the user and the manufacturer.

9.4 Procedures

9.4.1 For endless belts manufactured in circular moulds

In measuring the pitch length of a synchronous belt as illustrated in [Figure 2](#), the belt should be rotated at least two revolutions to seat it properly and to divide the total force equally between the two lengths of the belt. The pitch length shall be calculated by adding the pitch circumference of one of the pulleys to twice the measured centre distance. Check double-sided belts on both tooth faces separately.

9.4.2 For very long endless belts and open belts

A single-sided belt specimen is fixed with the belt's flat side on a device as illustrated in [Figure 3](#), and loaded with 50 % of the measuring force (see [Table 5](#)). The measuring plate of the device shall be brought into contact with the belts teeth and the measuring system shall be set to zero then. After that, the measuring plate shall be traversed as shown in [Figure 3](#) to the right side and brought into contact with the belt again at a distance of 1 000 mm (or 1 002 mm in case of AT3) corresponding to the exact number of teeth (see NOTE below). The real distance is read from the display of the measuring system. This distance corresponds with the belt length. Double sided belts shall be checked on both sides separately.

NOTE 1 000 mm equals

- 400 teeth for a pitch of 2,5 mm,
- 200 teeth for a pitch of 5 mm,
- 100 teeth for a pitch of 10 mm, and
- 50 teeth for a pitch of 20 mm.

1 002 mm equals 334 teeth for a pitch of 3 mm.

9.5 Belt length tolerances

The length tolerance for open belts is $\pm 0,8$ mm/m.

The length tolerances for endless manufactured belts are given in [Tables 6](#) and [7](#).

Table 6 — Tolerances for profile system T and AT — Endless belts from circular moulds

Dimensions in millimetres

Endless belt length	Tolerance \pm
up to 305	0,28
>305 up to 390	0,32
>390 up to 525	0,36
>525 up to 630	0,42
>630 up to 780	0,48
>780 up to 990	0,56
>990 up to 1 250	0,64
>1 250 up to 1 560	0,76
>1 560 up to 1 960	0,88
>1 960 up to 2 360	1,04
>2 360 up to 3 100	1,22
>3 100 up to 3 620	1,46
>3 620	consult supplier

Table 7 — Tolerances for endless belts (not made from circular moulds)

Endless belt length mm		Tolerance \pm (mm/m)
above	up to and including	
below	2 120	consult supplier
2 120	2 240	0,62
2 240	2 360	0,61
2 360	2 500	0,61
2 650	2 650	0,59
2 500	2 800	0,59
2 800	3 000	0,57
3 000	3 150	0,55
3 150	3 350	0,55
3 350	3 550	0,54
3 550	4 000	0,54
4 000	4 250	0,53
4 250	4 500	0,52
4 500	4 750	0,51
4 750	5 000	0,50
5 000	5 300	0,50
5 300	5 600	0,49
5 600	6 000	0,48
6 000	6 300	0,48

Table 7 (continued)

Endless belt length mm		Tolerance ±(mm/m)
above	up to and including	
6 300	7 100	0,48
7 100	8 000	0,47
8 000	9 000	0,46
over 9 000		consult supplier

The length tolerances given are only valid for belts with steel cord tension member. For other reinforcements, tolerances shall be confirmed between the manufacturer and the user.

10 Pulleys

10.1 General profile system T

The pulley is characterized by a trapezoidal groove profile. This groove profile is defined as the profile formed by the generating tool rack form required to machine-finish the trapezoidal profile. The profile is different for each pulley diameter, but can be closely approximated by a nominal groove profile over specified ranges of number of grooves.

NOTE For tolerances, see [Annex A](#).

10.1.1 Profile system T — Pulley groove dimensions and tolerances

Dimensions and tolerances for the pulley grooves for T2,5, T5, T10 and T20 pulleys are given in [Table 8](#) and shown in [Figure 4](#).

Table 8 — Profile system T — Pulley groove profile dimensions and tolerances

Dimensions in millimetres

Pulley profile	Number of grooves	b_r	h_g min	2ϕ $\pm 3^\circ$	r_b max	r_t
T2,5	up to 20/SE	1,75 $+0,05$	0,75 $+0,05$	50	0,2	0,3 $\pm 0,05$
	>20/N	1,83 $+0,05$	1,00	50	0,2	0,3 $\pm 0,05$
T5	up to 20/SE	2,96 $+0,05$	1,25 $+0,05$	50	0,4	0,6 $\pm 0,05$
	>20/N	3,32 $+0,05$	1,95	50	0,4	0,6 $\pm 0,05$
T10	up to 20/SE	6,02 $+0,10$	2,60 $+0,10$	50	0,6	0,8 $\pm 0,10$
	>20/N	6,57 $+0,10$	3,40	50	0,6	0,8 $\pm 0,10$
T20	up to 20/SE	11,65 $+0,15$	5,20 $+0,13$	50	0,8	1,2 $\pm 0,10$
	>20/N	12,60 $+0,15$	6,00	50	0,8	1,2 $\pm 0,10$

For special applications, i.e. backlash free drives, the dimension b_r may be corrected to achieve this special property of the synchronous drive. Pulleys are called “0-backlash pulleys” then.

10.1.2 Profile system T — Pulley groove profile

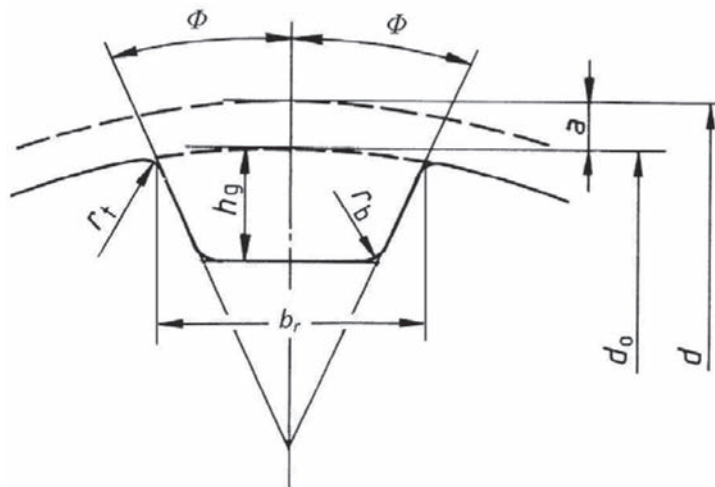

Figure 4 — Profile system T — Pulley groove profile

10.1.3 Profile system T — Pulley outside diameters

The pulley outside diameters for standard pulleys are given in Table 9. The relationship of the pulley outside and the pitch diameters is illustrated in Figure 4, value “a”.

Table 9 — Profile system T — standard pulley sizes

Dimensions in millimetres

Number of grooves	Pulley profile							
	T2,5		T5		T10		T20	
	Outside diameter d_0	Pitch diameter d	Outside diameter d_0	Pitch diameter d	Outside diameter d_0	Pitch diameter d	Outside diameter d_0	Pitch diameter d
10	7,46	7,96	15,08	15,92	29,97	31,83		
11	8,25	8,75	16,67	17,51	33,15	35,01		
12	9,05	9,55	18,26	19,10	36,34	38,20		
13	9,85	10,35	19,85	20,69	39,52	41,38		
14	10,64	11,14	21,44	22,28	42,70	44,56		
15	11,44	11,94	23,03	23,87	45,89	47,75	92,64	95,49
16	12,23	12,73	24,62	25,46	49,07	50,93	99,01	101,86
17	13,03	13,53	26,22	27,06	52,25	54,11	105,38	108,23
18	13,82	14,32	27,81	28,65	55,44	57,30	111,74	114,59
19	14,62	15,12	29,40	30,24	58,62	60,48	118,11	120,96
20	15,42	15,92	30,99	31,83	61,80	63,66	124,47	127,32
22	17,01	17,51	34,17	35,01	68,17	70,03	137,21	140,06
25	19,39	19,89	38,95	39,79	77,72	79,58	156,30	159,15
28	21,78	22,28	43,72	44,56	87,27	89,13	175,40	178,25
32	24,96	25,46	50,09	50,93	100,00	101,86	200,87	203,72
36	28,15	28,65	56,46	57,30	112,73	114,59	226,33	229,18

Table 9 (continued)

Number of grooves	Pulley profile							
	T2,5		T5		T10		T20	
	Outside diameter d_0	Pitch diameter d	Outside diameter d_0	Pitch diameter d	Outside diameter d_0	Pitch diameter d	Outside diameter d_0	Pitch diameter d
40	31,33	31,83	62,82	63,66	125,46	127,32	251,80	254,65
48	37,70	38,20	75,55	76,39	150,93	152,79	302,73	305,58
60	47,25	47,75	94,65	95,49	189,13	190,99	379,12	381,97
72	56,80	57,30	113,75	114,59	227,32	229,18	455,52	458,37
84	66,35	66,85	132,90	133,69	265,52	267,38	531,91	534,76
96	75,89	76,39	152,00	152,79	303,72	305,58	608,30	611,15

10.1.4 Profile system T — pulley width

The standard nominal pulley width and the minimum actual pulley width required [b_f for flanged pulleys and b'_f for unflanged pulleys (see [Figure 5](#))], are given in [Table 10](#). Users are advised that the values given for b'_f apply also to pulleys with only one flange. The minimum unflanged pulley width may be reduced when the alignment of the drive can be controlled, but shall not be less than the minimum flanged pulley width. Widths other than standard widths are available on request.

Table 10 — Standard pulley widths

Dimensions in millimetres

Pulley profile	Standard nominal belt width	Minimum pulley width	
		Flanged b_f min	Unflanged b'_f min
T2,5	4	5,5	8,0
	6	7,5	10,0
	10	11,5	14,0
T5	6	7,5	10,0
	10	11,5	14,0
	16	17,5	20,0
T10	25	26,5	29,0
	16	18,0	21,0
	25	27,0	30,0
T20	32	34,0	37,0
	50	52,0	55,0
	32	34,0	38,0
T20	50	52,0	56,0
	75	77,0	81,0
	100	102,0	106,0

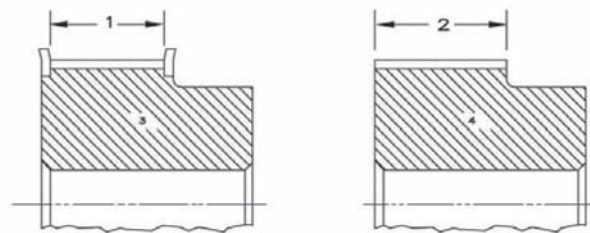

Key

- 1 b_f
- 2 b'_f
- 3 flanged pulley
- 4 unflanged pulley

Figure 5 — Minimum pulley width

10.2 General profile system AT

The pulley is characterized by a trapezoidal groove profile. This groove profile is defined as the profile formed by the generating tool rack form required to machine-finish the trapezoidal profile. The profile is different for each pulley diameter, but can be closely approximated by a nominal groove profile over specified ranges of number of grooves.

NOTE For tolerances, see [Annex A](#).

10.2.1 Profile system AT — Pulley groove profile dimensions and tolerances

Dimensions and tolerances for the pulley grooves for AT3, AT5, AT10 and AT20 pulleys are given in [Table 11](#) and shown in [Figure 6](#).

Table 11 — Profile system AT — Pulley groove profile dimensions and tolerances

Dimensions in millimetres

Pulley profile	b_h	h_g	2ϕ	r_b	r_t
AT3	1,65 +0,05	1,0 +0,05	50° ± 2°	0,25 -0,1	0,2 -0,05
AT5	2,7 +0,05	1,1 ±0,05	50° ± 3°	0,4 -0,2	0,7 -0,1
AT10	5,4 +0,1	2,35 ±0,05	50° ± 3°	0,5 -0,3	1,2 -0,2
AT20	10,8 +0,15	4,65 ±0,05	50° ± 3°	1,5 -0,2	2,5 -0,2

For special applications, i.e. backlash free drives, the dimension b_h may be corrected to achieve this special property of the synchronous drive.

10.2.2 Profile system AT — Pulley groove profile

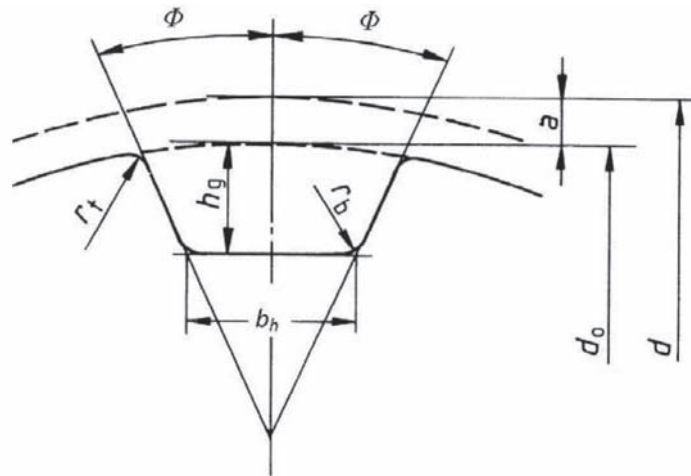

Figure 6 — Profile system AT — Pulley groove profile

10.2.3 Profile system AT — Pulley outside diameters

Pulley outside diameters for standard pulleys are given in Table 12. The relationship of the pulley outside and the pitch diameters is illustrated in Figure 6, value “a”.

Table 12 — Profile system AT — Standard pulley sizes

Dimensions in millimetres

Number of grooves	Pulley profile							
	AT3		AT5		AT10		AT20	
	Outside diameter d_0	Pitch diameter d	Outside diameter d_0	Pitch diameter d	Outside diameter d_0	Pitch diameter d	Outside diameter d_0	Pitch diameter d
15	13,91	14,32	22,65	23,87	45,93	47,75		
16	14,87	15,28	24,24	25,46	49,11	50,93		
17	15,82	16,23	25,84	27,06	52,29	54,11		
18	16,78	17,19	27,43	28,65	55,48	57,30	111,77	114,59
19	17,73	18,14	29,02	30,24	58,66	60,48	118,14	120,96
20	18,69	19,10	30,61	31,83	61,84	63,66	124,50	127,32
22	20,60	21,01	33,79	35,01	68,21	70,03	137,24	140,06
25	23,46	23,87	38,57	39,79	77,76	79,58	156,33	159,15
28	26,33	26,74	43,34	44,56	87,31	89,13	175,43	178,25
32	30,15	30,56	49,71	50,93	100,04	101,86	200,90	203,72
36	33,97	34,38	56,08	57,30	112,77	114,59	226,36	229,18
40	37,79	38,20	62,44	63,66	125,50	127,32	251,83	254,65
48	45,43	45,84	75,17	76,39	150,97	152,79	302,76	305,58
60	56,89	57,30	94,27	95,49	189,17	190,99	379,15	381,97
72	68,34	68,75	113,37	114,59	227,36	229,18	455,55	458,37
84	79,80	80,21	132,47	133,69	265,56	267,38	531,94	534,76
96	91,26	91,67	151,57	152,79	303,76	305,58	608,33	611,15

10.2.4 Pulley system AT — Pulley width

The standard nominal pulley width and the minimum actual pulley width required [b_f for flanged pulleys and b'_f for unflanged pulleys (see Figure 7)], are given in Table 13. Users are advised that the values given for b'_f apply also to pulleys with only one flange. The minimum unflanged pulley width may be reduced when the alignment of the drive can be controlled, but shall not be less than the minimum flanged pulley width. Widths other than standard widths are available on request.

Table 13 — Standard pulley widths

Dimensions in millimetres

Pulley profile	Standard nominal belt width	Minimum pulley width	
		Flanged b_f min	Unflanged b'_f min
AT3	6	7,5	10,0
	10	11,5	14,0
	16	17,5	20,0
	25	26,5	29,0
AT5	6	7,5	10,0
	10	11,5	14,0
	16	17,5	20,0
	25	26,5	29,0
AT10	16	18,0	21,0
	25	27,0	30,0
	32	34,0	37,0
	50	52,0	55,0
AT20	32	34,0	38,0
	50	52,0	56,0
	75	77,0	81,0
	100	102,0	106,0

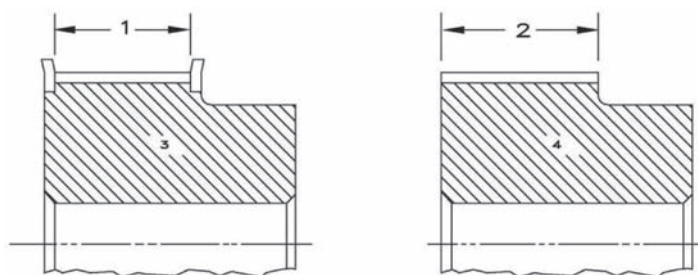

Key

- 1 b_f
- 2 b'_f
- 3 flanged pulley
- 4 unflanged pulley

Figure 7 — Minimum pulley width

Annex A (normative)

Pulley tolerances

A.1 Pitch-to-pitch tolerances

Tolerances on the amount of deviation of pulley pitch between adjacent teeth, and on the summation of deviations within 90° arc of a pulley, are given in [Table A.1](#). This tolerance applies to the distance between the same point on either the right or left corresponding flanks of adjacent teeth.

Table A.1 — Pitch-to-pitch tolerance

Dimensions in millimetres

Outside diameter d_o	Allowable deviation of pitch	
	Between any two adjacent teeth	Summation within a 90° arc ^a
up to 25,0	0,03	0,05
>25 up to 50	0,03	0,08
>50 up to 100	0,03	0,10
>100 up to 175	0,03	0,13
>175 up to 300	0,03	0,15
>300 up to 500	0,03	0,18
>500	0,03	0,20

^a The allowable deviation of pitch is to include the next full tooth past a 90° arc.

NOTE Dimensions of standard pulleys are given in [Tables 7](#) and [10](#).

A.2 Tolerances for outside diameter

Table A.2 — Tolerances for outside diameter

Dimensions in millimetres

Outside diameter d_o	Tolerance
up to 25	0/-0,05
>25 up to 50	0/-0,05
>50 up to 100	0/-0,08
>100 up to 175	0/-0,08
>175 up to 300	0/-0,10
>300 up to 500	0/-0,10
>500	0/-0,15

A.3 Axial circular runout

See [Table A.3](#).

Table A.3 — Axial circular runout

Dimensions in millimetres

Outside diameter range d_o	FIM ^a max
0 up to 100	0,10
100 < d_o up to 250	0,001 per millimetre of outside diameter
$d_o > 250$	0,25 + 0,000 5 per millimetre of outside diameter $d_o > 250$
^a Full indicator movement.	

A.4 Radial circular runout

See [Table A.4](#).

Table A.4 — Radial circular runout

Dimensions in millimetres

Outside diameter range d_o	FIM ^a max
d_o up to 200	0,05
$d_o > 200$	0,05 + 0,005 per 10 mm of outside diameter $d_o > 200$
^a Full indicator movement.	

A.5 Parallelism

Teeth shall be parallel to the axis of the bore within 0,001 mm per millimetre of face width.

A.6 Cylindricity

The maximum cylindricity will be 0,001 mm per millimetre of face width, provided the outside diameter is within the tolerance given in [Table A.2](#).

A.7 Quality specifications

The quality, finish and balance of pulleys shall comply with the requirements specified in ISO 254.

A.8 Flange dimensions

The flange dimensions are illustrated in [Figure A.1](#) and given in [Table A.5](#).

Table A.5 — Flange dimensions

Dimensions in millimetres

Pulley profile	Height of flange h
T2,5	0,8
AT3	1,0
T5 and AT5	1,2
T10 and AT10	2,2
T20 and AT20	3,2

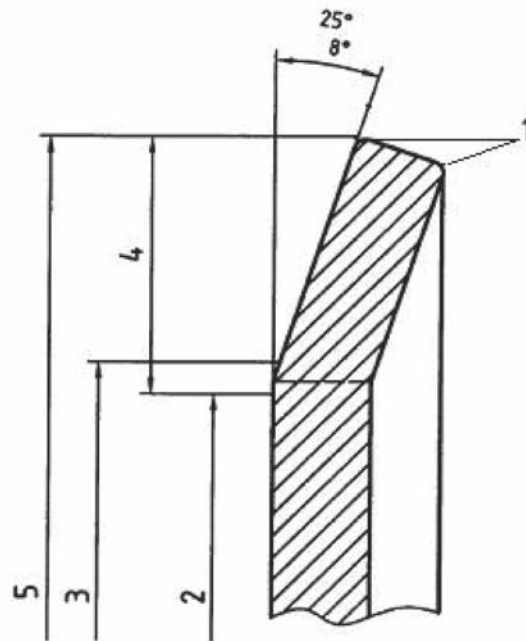
**Key**

- 1 break sharp corners
- 2 outside diameter, d_0
- 3 bend diameter, $(d_0 + 0,38 \text{ mm}) \pm 0,25 \text{ mm}$
- 4 minimum height of flange, h
- 5 flange outside diameter, $d_0 + 2h$

Figure A.1 — Flange dimensions

Bibliography

- [1] ISO 1101, *Geometrical product specifications (GPS) — Geometrical tolerancing — Tolerancing of form, orientation, location and run-out — Tolerances of form, orientation, location and run-out*
- [1] ISO 5288, *Synchronous belt drives — Vocabulary*

