**Transport information and control
systems — Manoeuvring Aids for Low
Speed Operation (MALSO) —
Performance requirements and test
procedures**

*Systèmes d'information et de commande des transports — Aides à la
conduite pour manœuvre à vitesse réduite (MALSO) — Exigences de
performance et modes opératoires*



PDF disclaimer

This PDF file may contain embedded typefaces. In accordance with Adobe's licensing policy, this file may be printed or viewed but shall not be edited unless the typefaces which are embedded are licensed to and installed on the computer performing the editing. In downloading this file, parties accept therein the responsibility of not infringing Adobe's licensing policy. The ISO Central Secretariat accepts no liability in this area.

Adobe is a trademark of Adobe Systems Incorporated.

Details of the software products used to create this PDF file can be found in the General Info relative to the file; the PDF-creation parameters were optimized for printing. Every care has been taken to ensure that the file is suitable for use by ISO member bodies. In the unlikely event that a problem relating to it is found, please inform the Central Secretariat at the address given below.



COPYRIGHT PROTECTED DOCUMENT

© ISO 2010

All rights reserved. Unless otherwise specified, no part of this publication may be reproduced or utilized in any form or by any means, electronic or mechanical, including photocopying and microfilm, without permission in writing from either ISO at the address below or ISO's member body in the country of the requester.

ISO copyright office
Case postale 56 • CH-1211 Geneva 20
Tel. + 41 22 749 01 11
Fax + 41 22 749 09 47
E-mail copyright@iso.org
Web www.iso.org

Published in Switzerland

Contents

Page

Foreword	iv
Introduction.....	v
1 Scope	1
2 Normative references	1
3 Terms and definitions	2
4 Classification	4
5 Functional and performance requirements	5
5.1 System activation	5
5.2 Driver interface and information strategy	5
5.3 Dynamic performance of object detection.....	7
5.4 Monitoring range coverage	8
5.5 Self-test capabilities and failure indication	14
5.6 Operation with trailers	15
6 Requirements and tests components	15
7 Operational test of obstacle detection	15
7.1 Test object.....	15
7.2 General ambient conditions	16
7.3 Test procedure.....	16
Annex A (informative) Test methods	18
Bibliography.....	21

Foreword

ISO (the International Organization for Standardization) is a worldwide federation of national standards bodies (ISO member bodies). The work of preparing International Standards is normally carried out through ISO technical committees. Each member body interested in a subject for which a technical committee has been established has the right to be represented on that committee. International organizations, governmental and non-governmental, in liaison with ISO, also take part in the work. ISO collaborates closely with the International Electrotechnical Commission (IEC) on all matters of electrotechnical standardization.

International Standards are drafted in accordance with the rules given in the ISO/IEC Directives, Part 2.

The main task of technical committees is to prepare International Standards. Draft International Standards adopted by the technical committees are circulated to the member bodies for voting. Publication as an International Standard requires approval by at least 75 % of the member bodies casting a vote.

Attention is drawn to the possibility that some of the elements of this document may be the subject of patent rights. ISO shall not be held responsible for identifying any or all such patent rights.

ISO 17386 was prepared by Technical Committee ISO/TC 204, *Intelligent transport systems*.

This second edition cancels and replaces the first edition (ISO 17386:2004), which has been technically revised.

Introduction

Today's aerodynamically-shaped vehicles often result in restricted rear and front visibility. Manoeuvring aids for low-speed operation (MALSO) enhance security and driver convenience during parking or manoeuvring situations at very low speed, e.g. in narrow passages. Drivers can avoid collisions with obstacles that cannot be seen but can be detected by the system and they can make more effective use of limited parking space.

MALSO systems are detection devices with non-contact sensors which assist the driver during low speed manoeuvring. MALSO systems indicate to the driver the presence of front, rear or corner objects when squeezing into small parking spaces or manoeuvring through narrow passages. They are regarded as an aid to drivers for use at speeds of up to 0,5 m/s, and they do not relieve drivers of their responsibility when driving the vehicle.

Transport information and control systems — Manoeuvring Aids for Low Speed Operation (MALSO) — Performance requirements and test procedures

1 Scope

This International Standard addresses light-duty vehicles, e.g. passenger cars, pick-up trucks, light vans and sport utility vehicles (motorcycles excluded) equipped with MALSO systems. It specifies minimum functionality requirements which the driver can generally expect of the device, i.e. detection of and information on the presence of relevant obstacles within a defined (short) detection range. It defines minimum requirements for failure indication as well as performance test procedures; it includes rules for the general information strategy but does not restrict the kind of information or display system.

MALSO systems use object-detection devices (sensors) for ranging in order to provide the driver with information based on the distance to obstacles. The sensing technology is not addressed; however, technology affects the performance-test procedures set up in this International Standard (see Clause 7). The current test objects are defined based on systems using ultrasonic sensors, which reflect the most commonly used technology at the time of publishing this International Standard. For other sensing technologies possibly coming up in the future, these test objects shall be checked and changed if required.

Visibility-enhancement systems like video-camera aids without distance ranging and warning are not covered by this International Standard.

Reversing aids and obstacle-detection devices on heavy commercial vehicles are not addressed by this International Standard; requirements for those systems are defined in ISO/TR 12155.

2 Normative references

The following referenced documents are indispensable for the application of this document. For dated references, only the edition cited applies. For undated references, the latest edition of the referenced document (including any amendments) applies.

ISO 2575, *Road vehicles — Symbols for controls, indicators and tell-tales*

ISO 15006, *Road vehicles — Ergonomic aspects of transport information and control systems — Specifications and compliance procedures for in-vehicle auditory presentation*

ISO 15008, *Road vehicles — Ergonomic aspects of transport information and control systems — Specifications and test procedures for in-vehicle visual presentation*

ISO 16750 (all parts), *Road vehicles — Environmental conditions and testing for electrical and electronic equipment*

3 Terms and definitions

For the purpose of this document, the following terms and definitions apply.

3.1 audible information and warning

acoustical signal that is used to present information about relevant obstacles, to the driver

EXAMPLE Pulses, speech.

NOTE Acoustical pulses can be coded mainly by carrier frequency, repetition rate and position of sound generator.

See Figure 1.

3.2 evaluation for information and advice

information about detected obstacles that, when the system is activated, will be evaluated to warn and advise the driver in order to help with the current low speed manoeuvre

See Figure 1.

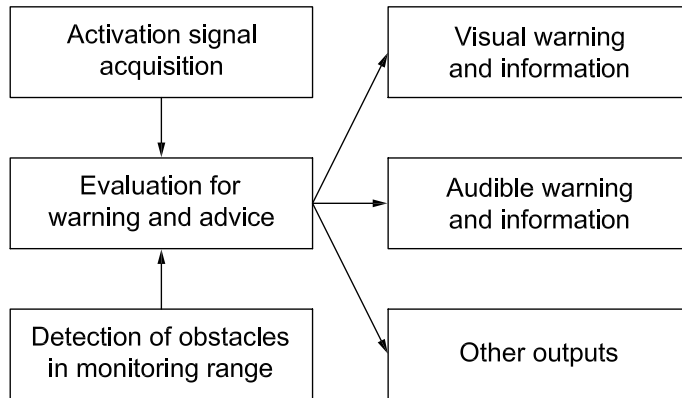

Figure 1 — Block diagram of the potential sub-functions of a manoeuvring aid for low-speed operation

3.3 manoeuvring aid for low-speed operation

system that, at low speeds (< 0,5 m/s), is capable of informing the driver of the presence of stationary obstacles in particular areas in close proximity to the subject vehicle, mainly during parking and manoeuvring in narrow passages

3.4 monitoring range

m.r.

specific three-dimensional space around the vehicle, which is divided into rear and front corner m.r., front, rear-1 and rear-2 m.r.

NOTE The covered monitoring ranges depend on the intended use of the system (see Clause 4).

See Figure 2.

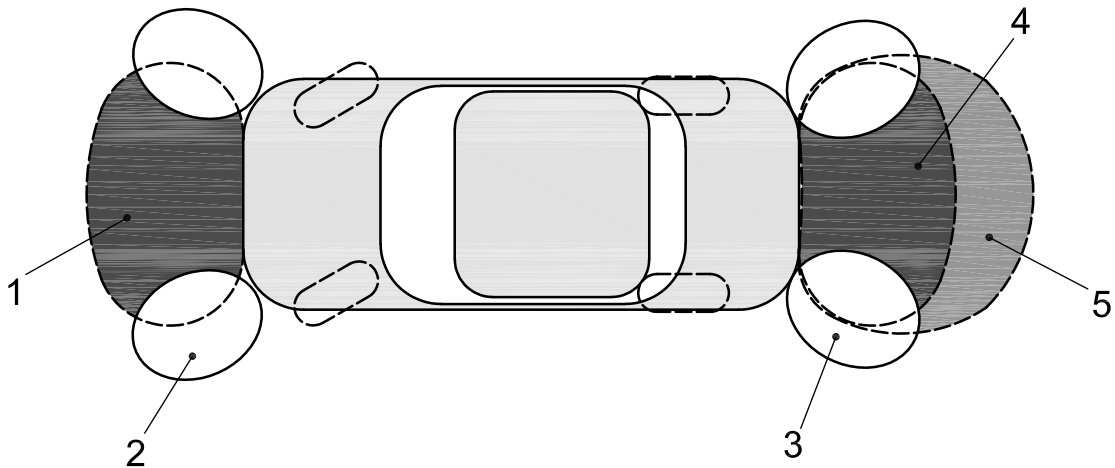
**Key**

- 1 front
- 2 front corner
- 3 rear corner
- 4 rear-1
- 5 rear-2

Figure 2 — Monitoring ranges (plan view)

3.5**reversing detection system**

system that gives an indication to the driver, when the reverse gear is selected, whether there are objects in the monitoring range

3.6**sensor**

component that detects objects in the monitoring range

NOTE There are a variety of sensor principles listed below which could be used.

The most common principle is the flight time measurement (e.g. radar, lidar, sonar). Active sensor elements create a pulsed or continuously modulated field of microwaves, (infrared) light, or ultrasonic sound. The reflected energy due to an object in the detection area is received, and the distance to the object is measured. The lateral position of the object is estimated based on the beam or field directional characteristics, or based on the timing relationships between sensors with overlapping coverage areas.

Alternative principles include distance measurement by triangulation principle and passive sensor systems using image processing.

3.7**system activation**

action of transitioning the system operation from a quiescent mode to an active one in which the system is monitoring the monitoring ranges, evaluating the objects detected and generating appropriate feedback to assist the driver

3.8**test object**

object with a specific material, geometry and surface for testing the monitoring range

NOTE This test object should give comparable results for the relevant sensor types.

**3.9
visual information and warning**

optical signal which is used to present information about relevant obstacles to the driver

EXAMPLE Telltale, display.

NOTE Visual information can be coded, e.g. by colour, repetition rate, symbols or text. The driver can be warned by continuous or pulsating signalling of possibly coloured telltales. Information can be graphical or alphanumeric.

**3.10
warning levels**

progressive critical levels of audible/visual/tactile/kinaesthetic information or feedback to the driver regarding the hazard environment

4 Classification

The MALSO system classification reflects the diversity of driving behaviour and market demand in different regions of the world. For example, in certain countries, drivers manoeuvre within a very tight area and have come to rely on warnings given at very short range. In other regions, drivers expect warnings to be given at a relatively longer range. A manufacturer may select the most suitable system parameters based on the driving style and expectations of the target driver population.

The manoeuvring aids for low-speed operation are classified according to their capability of covering the different monitoring ranges. Each monitoring range corresponds to a particular part of the vehicle boundary to prevent colliding with an obstacle. See Figure 2. The class of the system is indicated by an abbreviation corresponding to the monitoring ranges covered.

**Table 1 — Classification of manoeuvring aids for low-speed operation —
Abbreviations of monitoring ranges**

Monitoring range	Abbreviation	Detection distance m	Maximum driving speed m/s
Rear-1	R1	0,6	0,3
Rear-2	R2	1,0	0,5
Rear corner driver side	Rcd	0,5	0,3
Rear corner passenger side	Rcp	0,5	0,3
Front	F	0,6	0,3
Front corner driver side	Fcd	0,5	0,3
Front corner passenger side	Fcp	0,5	0,3

Any combination of monitoring ranges may be used, if it is beneficial for the intended use of the system.

The corner type systems have monitoring ranges restricted to particular corners of the vehicle and are mainly intended to assist the driver while driving through narrow passages.

For convenience and most efficient use of the manoeuvring aid the driver shall be informed about the type of system the vehicle is equipped with, according to the classification above.

5 Functional and performance requirements

5.1 System activation

5.1.1 Systems with manual activation

The system is turned ON and OFF by the driver with a switch or push-button. After activation, the system may indicate readiness for service acoustically or visually. This indication shall be clearly distinguishable from distance information about obstacles.

5.1.2 Systems with automatic activation

The system is activated/deactivated automatically according to the driving situation. The possible monitoring ranges (see Clause 4) may be activated separately in order to avoid nuisance signals. After automatic activation, readiness for service may be indicated to the driver. There may be an on/off switch or push-button to override automatic (de)activation.

Activation criteria are **Reverse gear selected** on the one hand and **speed below a specified limit v_{on}** on the other hand. Deactivation criteria may be **Gear other than reverse is selected, speed beyond a specified limit v_{off} or distance moved since last system activation greater than x_{off}** . The speed limits, v_{on} and v_{off} , and the distance limit, x_{off} , may be defined appropriately to the sensor technology and the intended use of the system; however, v_{on} and v_{off} shall be $\geq 0,5$ m/s or $\geq 0,3$ m/s, depending on the monitoring range under consideration (see Table 1), since these are the maximum velocities supported by the system.

Table 2 shows how the different existing monitoring ranges should be activated.

Table 2 — System activation/deactivation criteria

Monitoring range	Reverse gear selected	Gear other than reverse is selected	
		$v < v_{on}$	$v \geq v_{off}$ OR $x > x_{off}$
Front	o	+	–
Front corners	o	+	–
Rear	+	o	–
Rear corners	+	o	–
“o” indicates optional. “+” indicates active. “–” indicates inactive.			

On vehicles with automatic transmission the MALSO system may be deactivated if the P (parking) gear position is selected. It is also possible to deactivate the system while the parking brake is engaged.

5.2 Driver interface and information strategy

5.2.1 General information presentation

For the driver interface, at least the audible information channel shall be used. Visual information and warning may be used as a supplement. A standardized information strategy will be the basis for the development of both types of information components, as this makes the use in different vehicles easier and safer. The most relevant information for the driver is the distance, i.e. the clearance, between the vehicle boundary and an obstacle. The location of the obstacle relative to the vehicle may be indicated as additional information.

Failures shall be indicated to the driver as well.

A general information strategy cannot be established because of the following reasons:

- there are many different ways of coding the information;
- each car manufacturer will integrate the manoeuvring aids into its driver-information system with its specific driver interface.

Subclauses 5.2.2 to 5.2.5 may be regarded as guidance in the implementation of an information strategy.

5.2.2 Audible information

The audible information shall be presented in accordance with ISO 15006.

The following basic code is recommended for the audible information channel:

- a) Distance should be coded into at least two levels. These zones may be represented by different repetition rates, with the basic rule that a high repetition rate or a continuous sound corresponds to short distances. If a different or an additional code is used it should not interfere with the basic rule.
- b) The different areas may be represented by different carrier frequencies (e.g. high frequency for the front, low frequency for the back of the vehicle). In this case, not more than two different areas/carrier frequencies should be used. Synthesised or recorded voice messages may also be used.
- c) The activation/deactivation of the system and the indication of failure/disturbance may be presented by an audible signal, clearly distinguishable from the other signals.

5.2.3 Visual information

The visual information shall be presented in accordance with ISO 15008.

If the visual information channel is used as a supplement to the audible channel, the following basic code is recommended:

- a) The information should be codified into at least two levels, represented by multiple colours: for example, red for level 1 (imminent collision level) and yellow or green for level 2 (attention level). If a different code or an additional advisory level is used, it should not interfere with these basic code elements. The two levels may be subdivided by using more than one display element with the same colour, e.g. a bar graph with three red and three yellow bars, allowing for six sub-levels. If a monochromatic element is used instead of multiple colours, the two levels may be represented by a combination of continuous and flashing illumination, or a display consisting of incremental bars.

Figure 3 shows the warning levels for the rear monitoring range.

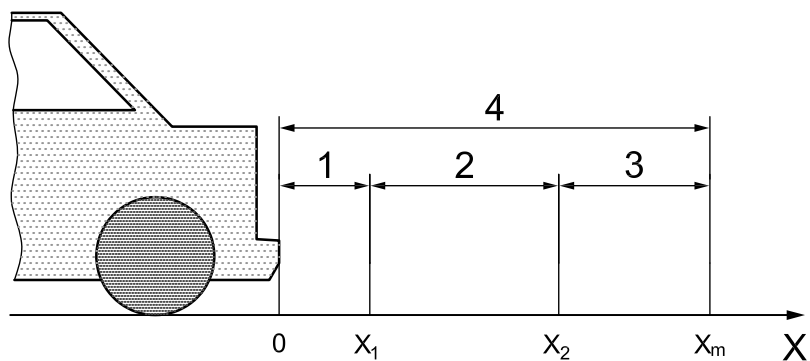

Key

1 level 1	3 advisory level
2 level 2	4 rear monitoring range

Figure 3 — Warning levels for rear monitoring range

- b) The display should be located so as to minimize the likelihood of inducing drivers to change their direction of vision. For example, it is recommended to place the display for the rear monitoring range in the rear part of the passenger compartment, because this allows drivers to watch the display while simultaneously looking through the rear mirror or over their shoulder directly through the rear window. For the same reason it is recommended to locate the display for the front monitoring range in the dashboard.
- c) It is recommended to indicate the activation/deactivation and malfunction of the system by a telltale or a symbol in all active displays of the system. These symbols shall be in accordance with ISO 2575.

5.2.4 Combination of visual and audible information

A combination of visual and audible information may be used to improve the system performance or to reduce the possibility of annoying the driver and passengers, taking into account the specific advantages of both information channels.

Level 1 (imminent collision level) information shall be given audibly and may additionally be given visually; level 2 (attention level) information may, however, be given by the visual or the audible channel only.

If the intensity of the audible information presentation can be reduced by the driver, e.g. from a menu of the onboard human-machine interface (HMI) system, there should be a note in the user manual or a message in the dialog with the HMI system, stating that warnings may not be perceived in time if the volume is set too low.

5.2.5 Duration of signalling

In general, the signalling of an obstacle shall be maintained as long as the obstacle is detected and shall cease when the obstacle is no longer detected or the system is deactivated. For activation/deactivation criteria of the system and specific monitoring ranges refer to 5.1.

In order to reduce annoyance of the driver, the system may automatically switch off the audible signal temporarily after a certain time (to be defined by the manufacturer). The system, however, shall remain in the active state.

As soon as the distance to the obstacle decreases, the audible signal shall be switched on automatically again. In the case of an increasing distance to the obstacle the audible signal may remain switched off.

If a visual display supplements the audible information channel, the system may automatically switch off the audible signal temporarily as described in the paragraph above. The visual signalling, however, should be maintained.

The driver may select temporary suppression of the audible signal manually. In this case the audible signal shall remain suppressed until the driver switches it on again; however, the audible signal shall be automatically reinstated when the system is activated the next time. For activation conditions refer to section 5.1.

5.3 Dynamic performance of object detection

5.3.1 Relative velocity of objects

The system shall be able to detect stationary objects while the vehicle itself is either stationary or moving at a speed up to 0,3 m/s. Systems classified R2 (see Clause 4) shall be able to detect stationary objects in the rear-2 monitoring range while moving at a speed up to 0,5 m/s.

5.3.2 Start-up detection delay

The start-up detection delay is defined as the time interval between the activation of the MALSO system and the moment the MALSO system presents to the driver the correct information about a relevant obstacle already present in the monitoring range under consideration.

NOTE 1 The activation criteria can be different for the different monitoring ranges and are defined by the system designer. For possible options see 5.1. When measuring the start-up detection delay, care must be taken that the activation criteria for the monitoring range under consideration are fulfilled.

If the MALSO system does not provide a readiness-for-service indication, the start-up detection delay is measured from the moment the ignition is set to ON and the engine is running.

NOTE 2 The engine is regarded as running as soon as the battery charging voltage has reached 90 % of the typical battery voltage after the break-in during cranking.

Background: on an increasing number of vehicles an electronic power management system switches off the power supply of the MALSO system if the engine is not running. On these vehicles the start-up detection delay can only be measured from the moment the engine is running. On many other vehicles, including hybrid electric vehicles, the MALSO system is fully operational, regardless if the engine is running or not. On those vehicles, the compliance with the following requirement can optionally be proven without starting the engine. In this case the measurement of the start-up detection delay shall start at the moment the battery voltage reaches 90 % of the stationary voltage level after turning the start-up switch to ON.

The start-up detection delay shall not exceed 1,5 s. The time needed to settle system operation and to accomplish internal system and sensor tests is included in the start-up detection delay.

If the MALSO system provides a readiness-for-service indication – either audible or visual or both – the start-up detection delay is measured from the moment the readiness-for-service indication ends. The average start-up detection delay shall not exceed 600 ms. This allows for a period of silence between the audible sound of the readiness-for-service tone and the audible sound of the MALSO information tone.

NOTE 3 In case other vehicle systems (such as a navigation display) are used to display MALSO information, the appearance of the start-up screen on the display system is treated as the MALSO readiness-for-service indication.

5.3.3 Detection latency

As long as the system is active the time delay between appearance of a relevant obstacle and presentation of the correct information to the driver shall not exceed 500 ms in all monitoring ranges. This capability is proved by a suitable test procedure with an accuracy better than one tenth of the measured time delay.

For reference, examples of test procedures are given in Annex A.

The delay is calculated as the arithmetic mean of at least 10 tests. The mean delay to indication within these tests shall not exceed 500 ms and no single value shall exceed 600 ms.

5.4 Monitoring range coverage

5.4.1 Sections of the monitoring range

According to Clause 3, the total monitoring range is divided into seven monitoring ranges (see Figure 2). Each monitoring range is characterized by horizontal and vertical areas of relevance.

5.4.2 Horizontal areas of relevance

The horizontal areas of relevance are the two-dimensional projections of the monitoring ranges on to the driveway. The minimum detection distances as measured from the vehicle boundary are defined in Table 1.

The first 0,2 m starting from the vehicle boundary (see Figure 4) shall not be tested, because state-of-the-art sensing technology cannot guarantee detection in this close proximity.

In order to perform the operational test described in Clause 7, the relevant monitoring range shall be scanned horizontally with test object H, vertically with test object V. Each detected grid position is represented by a covered square with edge lengths of dx and dy ($dx = 0,1$ m, $dy = 0,1$ m for testing the horizontal coverage) and its centre at the position of the longitudinal axis of the standard obstacle.

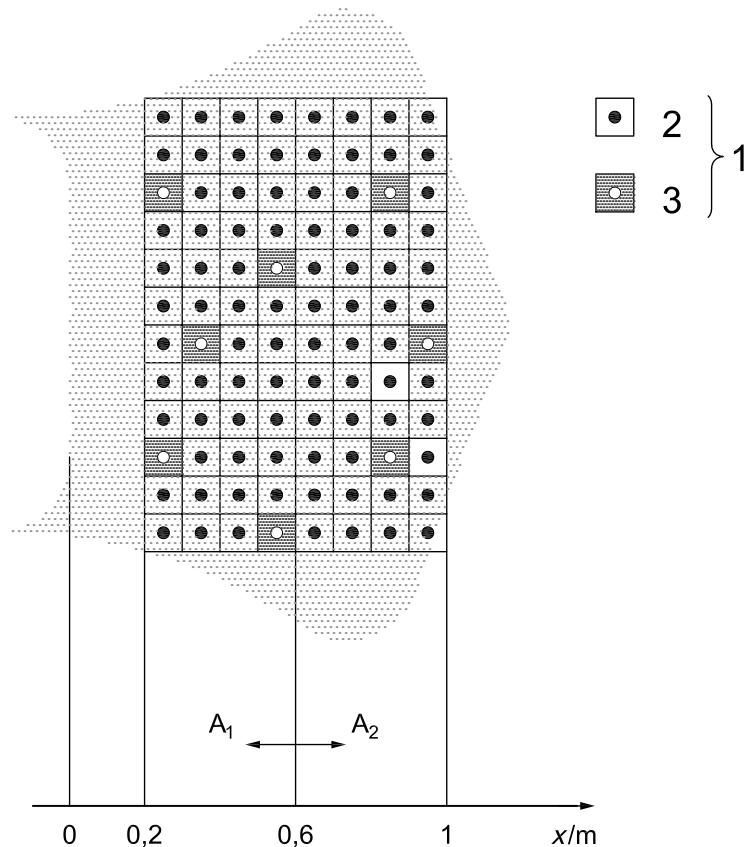
**Key**

- 1 test object
- 2 detected
- 3 not detected

Figure 4 — Determination of the rear horizontal coverage ratio in the sub-areas A_1 and A_2

The coverage ratio is defined as the ratio of the covered area over the total area of relevance.

EXAMPLE For a total area of relevance of 96 cells with a covered area of 88 cells, the average coverage ratio is 91,7%. The area of a single detection hole is defined as the square dx^2 corresponding to a “not detected” standard obstacle.

NOTE The small error due to the overestimation of the area by the integer number of cells can be neglected.

For the evaluation of the performance tests, the monitoring range is divided into a near range, A_1 , that extends from the vehicle boundary up to 0,6 m, and A_2 which covers the range beyond 0,6 m. These sub-areas are not related to the warning-level ranges. An example is shown in Figure 4 for the rear horizontal area of relevance. The coverage ratio shall be determined separately for each of the two sub-areas.

5.4.3 Rear horizontal area

In order to simplify the performance test procedure, the rear horizontal area of relevance is represented by a rectangle that begins 0,2 m off the rear vehicle boundary and extends to the maximum detection distance, which is 0,6 m for R1 and 1,0 m for R2.

The width of the rectangle, w_r , is equal to the vehicle width, measured along the rear axle. The dimensions shall be rounded up to the nearest 0,1 m.

The grid positions of the centre of test object H within this rectangle are shown in Figure 5. The grid is arranged symmetrically to the vehicle centre line.

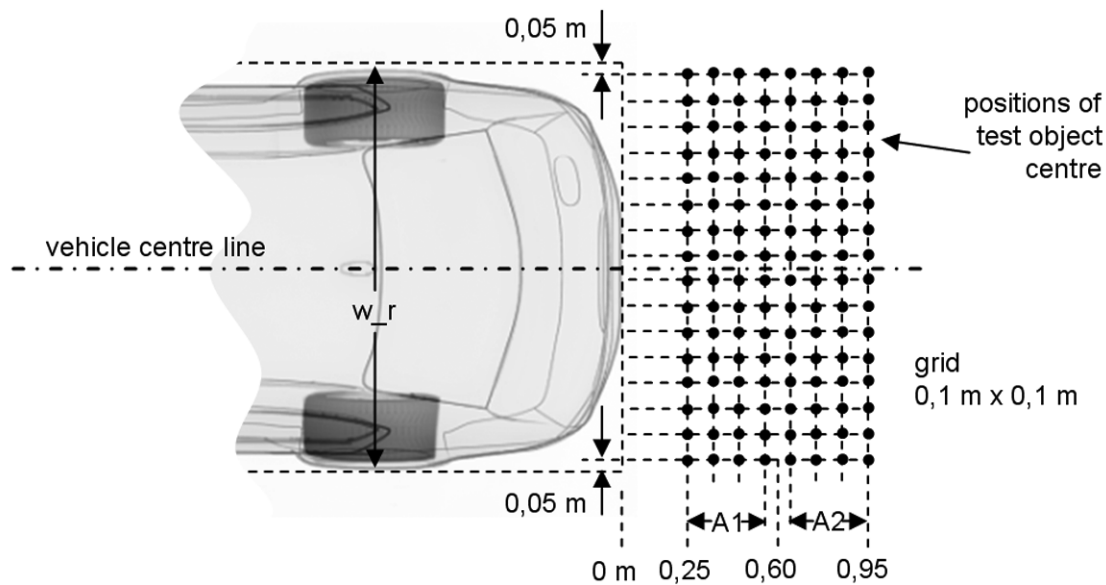

Figure 5 — Grid positions for testing the horizontal coverage of the rear monitoring range

5.4.4 Front horizontal area

The front horizontal area of relevance is represented by an area that begins 0,2 m off the front vehicle boundary and extends to the maximum detection distance, which is 0,6 m. The width of this area, w_f , is equal to the vehicle width, measured along the front axle. The dimensions shall be rounded up to the nearest 0,1 m.

In contrast to the rear horizontal area of relevance, which is simply a rectangle, the test grid positions of the front horizontal area are located on an area that follows the contour of the front bumper which has a distinctive convex shape on many vehicles. There are two different methods to construct the test grid which give comparable test results. The test engineer responsible for conducting the test may choose the method that suits best the capabilities of the available test equipment. In either case the grid is arranged symmetrically to the vehicle centre line.

Method 1:

The distance lines perpendicular to the driving direction are replaced by a curve that follows the shape of the front bumper. The curve is parallelly displaced in the driving direction by multiples of 0,1 m. By using this curve instead of straight lines, the distance to obstacles in the driving direction is always referred to the vehicle surface, even in cases with extremely round or arrow-shaped front bumpers. The curve follows the shape of the front bumper (vertical projection on the ground as shown in Figure 6) between the two “constructed vehicle corners”. For the construction of the corners see Figure 7. Left and right of the corners, the curve is completed by straight sections perpendicular to the driving direction to cover the whole vehicle width, w_f .

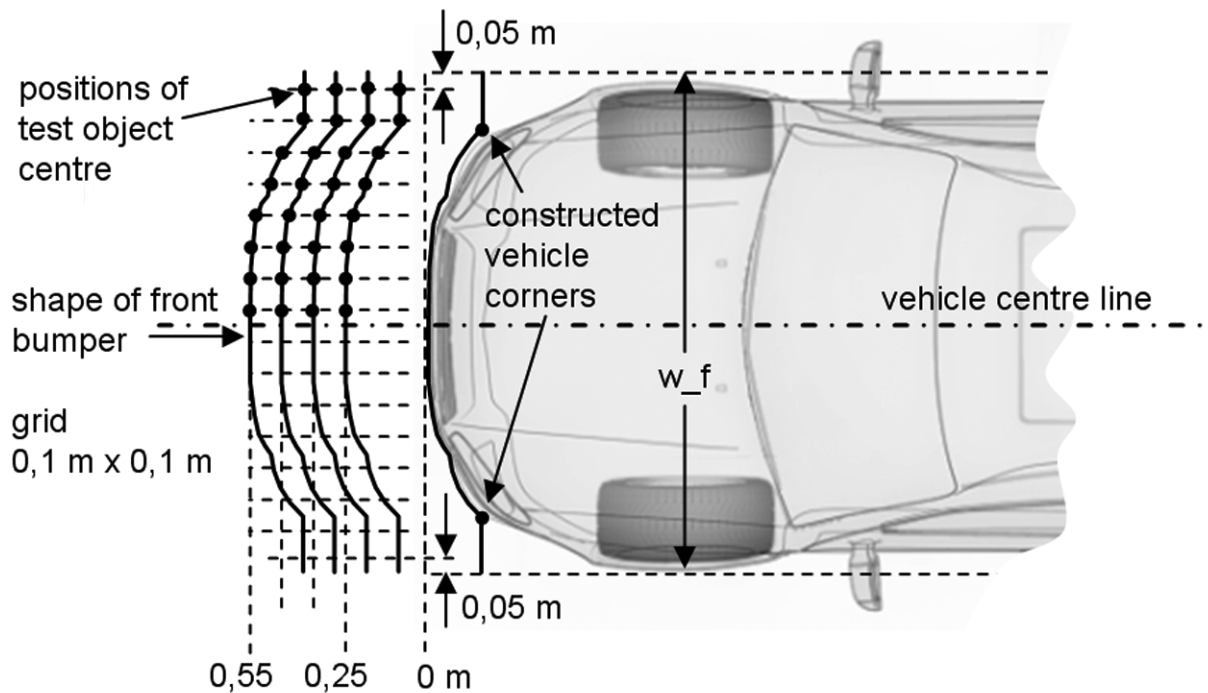

NOTE The positions of the test object centre are shown only in the upper part of the figure (right side of vehicle).

Figure 6 — Grid positions for testing the horizontal coverage of the front monitoring range following method 1

Method 2:

The underlying grid is still rectangular similar to the rear horizontal area. However, the tested grid positions are cut out of the rectangle by two curves that follow the shape of the front bumper (vertical projection on the ground as shown in Figure 7) between the two “constructed vehicle corners”. For the construction of the corners see Figure 8. Left and right of the corners, the curve is completed by straight sections perpendicular to the driving direction to cover the whole vehicle width, w_f .

The first curve has a distance of 0,2 m to the bumper, measured on the vehicle centre line; the second curve has a distance of 0,6 m.

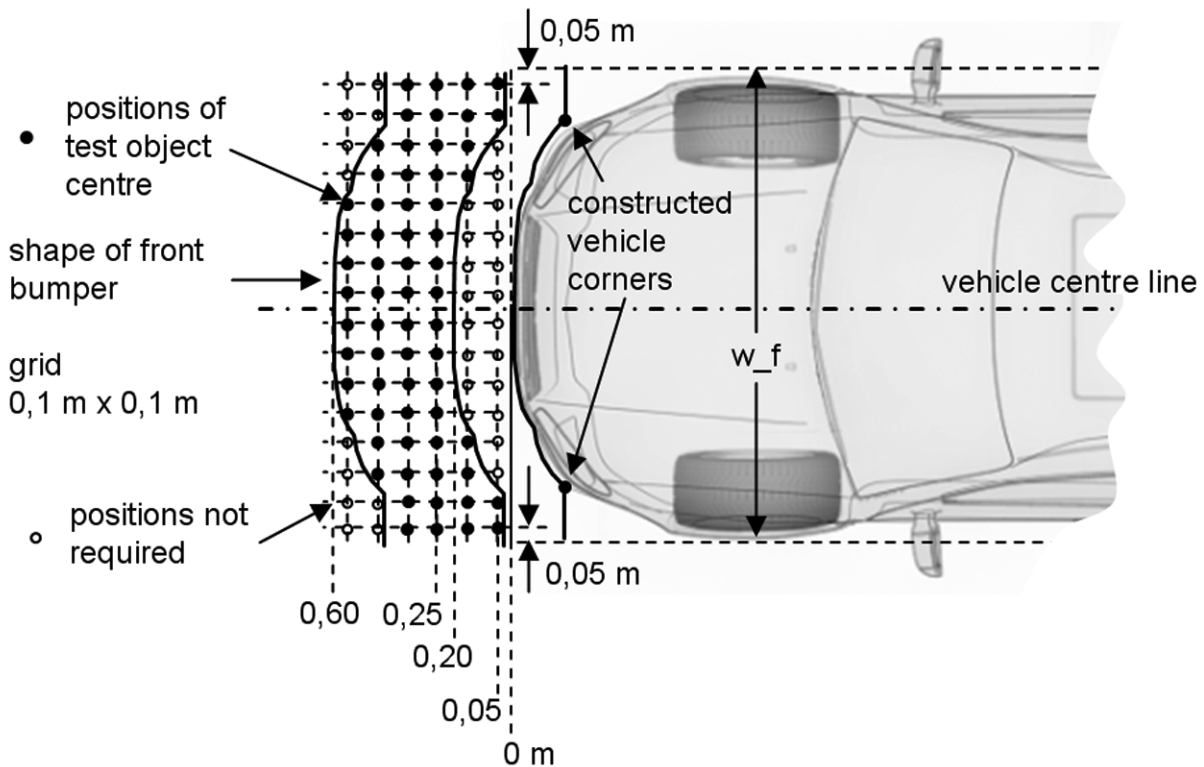

Figure 7 — Grid positions for testing the horizontal coverage of the front monitoring range following method 2

5.4.5 Corner horizontal areas

For the definition of the corner horizontal areas of relevance, the following “brick definition” method shall be used:

- 1) Draw a rectangular box close around the vehicle outline.
- 2) Draw lines from each box corner to the vehicle at an angle of 45°.
- 3) The intersections of these lines and the vehicle boundary are the vehicle corners.
- 4) The elliptical areas at each corner indicate the horizontal areas of relevance to be evaluated in the test procedure using seven square grid positions with $dx = dy = 0,1$ m (refer to Figure 8), the centres of which correspond to the positions of the longitudinal axis of the standard test obstacle.
- 5) The inclination of the ellipses to the straight forward/backward direction is 30° for the rear corners and 45° for the front corners.

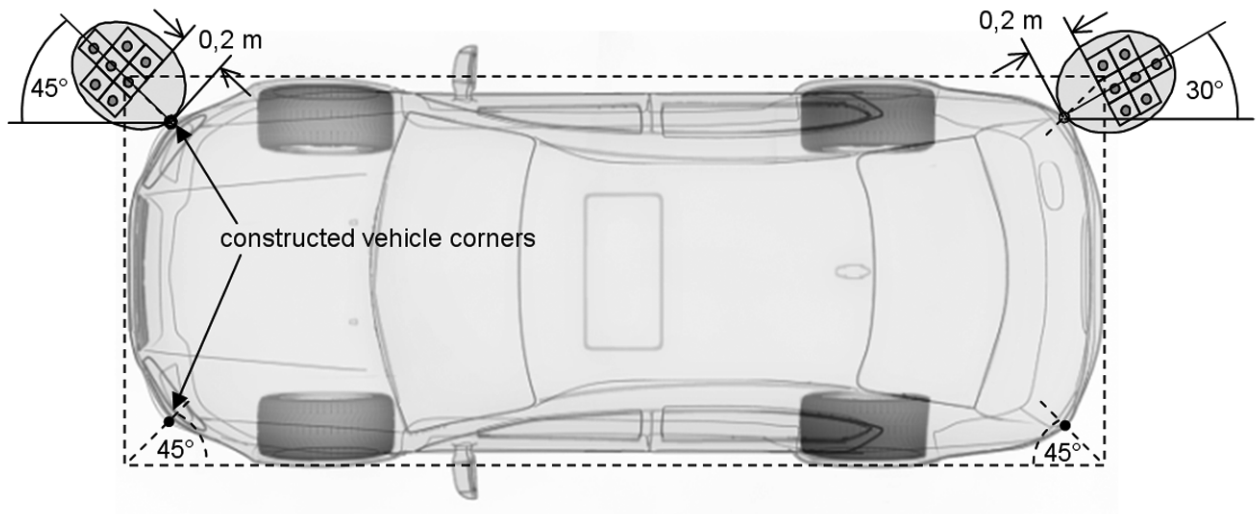

Figure 8 — “Brick definition” of vehicle corners and minimum corner detection ranges

5.4.6 Minimum coverage ratios

The minimum required coverage ratios for the front and rear horizontal areas of relevance are as follows:

- 90 % in A1;
- 87 % in the rear-2 area of A2.

The minimum coverage ratios for corner areas of relevance shall be 100 %.

Within the whole monitoring range, there shall be no more than two contiguous detection holes in a straight line, either horizontally, vertically or diagonally in the horizontal plane.

5.4.7 Vertical areas of relevance

In order to simplify the performance test procedure, the vertical areas of relevance are represented by rectangles that begin 0,2 m off the vehicle boundary and extend to the maximum detection distance in the particular monitoring range (see Clause 4). In the front and the rear monitoring range, the test shall be carried out using test object V placed in a vertical plane coinciding with the longitudinal axis of the vehicle. Refer to the horizontal monitoring ranges, shown in Figure 8, for the inclination of the corner vertical areas of relevance with respect to the vehicle boundary.

For testing the vertical coverage, it is sufficient to use a 0,2 m grid ($dx = dy = 0,2$ m), since the capability of covering the whole area without excessive holes is already proven by the test of the horizontal areas. The height of the rectangles is 0,6 m, corresponding to three lines of grid squares, the centres of which correspond to the positions of the longitudinal axis of the standard test obstacle.

An example for the rear monitoring range is depicted in Figure 9.

The centre of the lower line shall be 0,30 m above ground. In order to allow for the angular detection characteristics and different installation height of common sensors, at least one cell in column A (nearest to the bumper) shall be covered.

Dimensions in centimetres

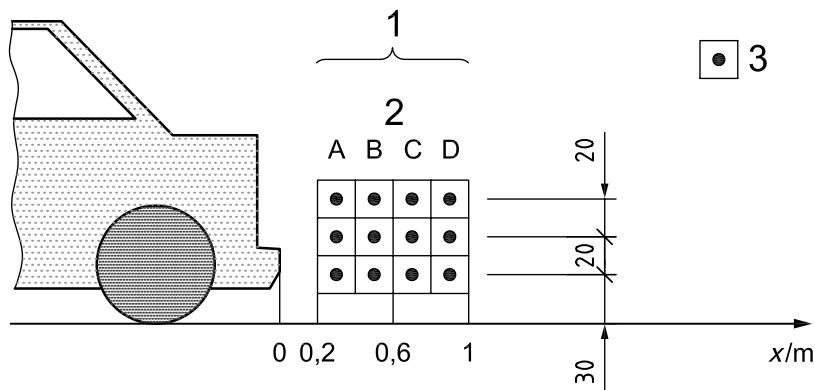

Key

- 1 rear vertical area of relevance
- 2 column
- 3 test object grid position

Figure 9 — Determination of the rear vertical area coverage ratio by the test procedure

The minimum coverage shall be as defined in Table 3. See Table 1 for the detection distances within the different monitoring ranges.

Table 3 — Vertical coverage (minimum number of covered cells)

Monitoring ranges	Column			
	A	B	C	D
Rear-2	1	2	2	1
Rear-1 and front	1	2	0	0
Rear and front corner	1	1	0	0

5.5 Self-test capabilities and failure indication

The system shall provide the following self-test functions (at least after each system activation):

- a) electronic circuit and wiring The self-test unit shall check the function of the electronic components of the system.
- b) sensor components The self-test unit shall check whether there is any damage to the sensor elements which would lead to a malfunction of the system.

Procedures a) and b) shall:

- be executed automatically to detect faults leading to a failure of the system function;
- generate a warning signal [see 5.2.2 c) and 5.2.3 c)] whenever a fault condition is detected.

5.6 Operation with trailers

5.6.1 Trailer hitch handling

A trailer hitch mounted on the host vehicle may affect the proper function of the sensors on the one hand and may extend the rear boundary of the vehicle on the other.

Especially if a detachable trailer hitch is used, particular care shall be taken that the mounting of the hitch will not result in poor coverage of the rear monitoring range. It shall be taken into account that the hitch will most probably protrude beyond the bumper and will thus determine the vehicle boundary.

If proper functioning with the hitch mounted cannot be effected, either the system shall automatically shut off when a hitch is mounted or the driver shall be able to deactivate the system manually. The user manual of the vehicle shall describe the appropriate operation in these cases.

5.6.2 System operation with trailer

For systems that cannot be deactivated manually, the electrical circuit of the vehicle shall be designed in such a way that the reversing detection system will automatically be suspended as soon as the electrical connection between towing and trailing vehicle is in operation. However, if the trailer is fitted with compatible sensors, these should now inform the driver of obstacles whilst reversing.

6 Requirements and tests components

The system components shall be designed according to specific automotive requirements. This shall be proved by standardized tests defined by the car manufacturer. As an alternative to car manufacturers' specific test procedures, ISO 16750 (all parts) may be the basis for component test procedures.

7 Operational test of obstacle detection

7.1 Test object

7.1.1 Standard test object definition

The purpose of 7.1 is to define the requirements of the standard test objects to be used when testing a system's obstacle detection capability.

NOTE If certain sensing technologies require a different standard, this must be investigated and evaluated. The plastic pipe for ultrasonic-based systems was chosen because it is commercially available, inexpensive, easily replaced in case of loss or damage, and easily transportable. For the same reasons the metal pipe for radar-based systems was chosen. Furthermore, it provides a well-defined radar cross-section (RCS) signature for any given frequency.

It is recognised that these test objects will represent different echo characteristics to different sensors, but this is true for any object chosen. The intent is to keep a constant test object that is representative of at least some of the expected real world application objects (i.e. a round wooden, metal or concrete pole).

The geometry, reflection and absorption properties of the test object should lead to easy testability and good representation of a real obstacle. The standard obstacle should not favour one of the physical principles and should represent the most relevant objects in real manoeuvring situations. The intent of standardizing the test object is so that embodiments (systems) from various suppliers can be designed and manufactured with comparable performance to ensure that the minimum performance expectations of the driver are fulfilled.

7.1.2 Ultrasonic-based systems

Reflectivity measurements on relevant objects have been conducted. Experiments have shown that the reflection of ultrasound does not significantly change for different materials, as long as the surface is smooth and “hard” for sound. For instance, metal and wooden poles exhibit the same sonic reflectivity as plastic poles of the same diameter. It should be noted that for use as a test object, metal poles are more rigid and can be more accurately manufactured.

Table 4 — Test objects for ultrasonic-based systems

Monitoring range		Material	Diameter	Length
All horizontal areas Test object H		Wood, metal or hard plastic	75 mm	1 _{+0,2} ⁰ m
Vertical areas Test object V	Rear-1, rear-2, front	Wood, metal or hard plastic	75 mm	Length equal to width of test vehicle bumper plus 20 % to 40 %
	Corners	Wood, metal or hard plastic	75 mm	1 _{+0,2} ⁰ m

7.1.3 Radar-based systems

Reflectivity measurements on relevant objects have been conducted. The results of this testing proved that the following tubular test objects are suitable as representations of real objects that were detectable by systems using radar-based sensors.

Table 5 — Test objects for radar-based systems

Monitoring range		Material	Diameter	Length
All horizontal areas Test object H		Metal	25 mm	1 _{+0,2} ⁰ m
Vertical areas Test object V	Rear-1, rear-2, front	Metal	25 mm	Length equal to width of test vehicle bumper plus 20 % to 40 %
	Corners	Metal	25 mm	1 _{+0,2} ⁰ m

7.2 General ambient conditions

During testing, the wind speed shall not exceed 5,4 m/s (wind force 3). Temperature shall be between 5 °C and 30 °C under non-precipitating conditions (not raining, sleeting, snowing, etc.). The test location shall be on a flat, dry, asphalt or concrete surface. The tests shall not be affected by reflections, neither of sonic nor of electromagnetic waves from walls in the environment, auxiliary test equipment or other objects.

7.3 Test procedure

7.3.1 Test setup

Perform the operational test on a vehicle or test structure that allows the installation conditions of the selected vehicle model or selected vehicle range to be reproduced. In case a vehicle is used to perform the test, it shall have kerb weight. A tolerance of +5 % may be allowed. If the ride height is adjustable, it shall be set to normal driving condition on paved roads.

Sensor surfaces shall be visibly clean and free of contamination.

Depending on the class of the manoeuvring aid (see Clause 4), the detection performance shall be tested in the rear monitoring range, the front monitoring range and the corner monitoring ranges.

7.3.2 Test 1 — Coverage of horizontal areas of relevance

7.3.2.1 Test

Position test object H perpendicularly on the ground in the monitoring range in such a way that its longitudinal axis is positioned rigidly in the grid positions in accordance with 5.4.2. If the horizontal area of relevance depends on the steering angle, the test shall be performed with the steering in a neutral (straight-ahead) position.

7.3.2.2 Evaluation

Check the coverage ratio for each sub-area of the horizontal area of relevance. Detection shall take place unambiguously with an uninterrupted sequence of the signal corresponding to the warning level. The minimum coverage ratio as defined in 5.4.2 shall be attained in each sub-area.

7.3.3 Test 2 — Coverage of vertical areas of relevance

7.3.3.1 Test

Secure the test object V in a rigid horizontal position in the monitoring range with its three-dimensional centre located on the appropriate grid positions (the grid has to cover the vertical area of relevance in accordance with 5.4.7).

7.3.3.2 Evaluation

See 7.3.2.2.

Annex A (informative)

Test methods

This International Standard does not specify the test method for the evaluation of the system reaction time (see 5.3.3), but a sufficient measuring accuracy (one-tenth of the measured time) shall be guaranteed.

For reference, one test method proposal is described in a) to g).

- a) Prepare a video camera.
- b) Input the output signal from a microphone that is attached to collect the sound of the audible warning, to the sound input of a video camera.
- c) The video camera is fixed to record a video of the test target that is dropping from a reasonable height into the monitoring range. The distance of the test object to the vehicle boundary shall correspond to approximately 80 % of the specified maximum detection distance in the respective monitoring range. The approximate test object distance is 0,4 m in the corner monitoring ranges, 0,5 m in F and R1 and 0,8 m in R2. If the vehicle or system manufacturer specifies a maximum detection distance larger than 1,2 m in R2 the test object shall be positioned at a distance of 1,0 m in this test case. Choose the exact position so that the test object is detected faultlessly after being dropped.
- d) Power ON the video camera and start to record.
- e) Lower the test target very slowly into the monitoring area. Stop the target at the position y_0 when the system begins to warn. Record this position with the video camera.
- f) Drop the target from a reasonable height, e.g. 1,0 m, into the monitoring area and record both the movement of the test target and the sound of audible warning with the video camera.
- g) The system reaction time is equal to the time elapsed from the moment the target passes point y_0 to the beginning of the warning.

Dimensions in metres

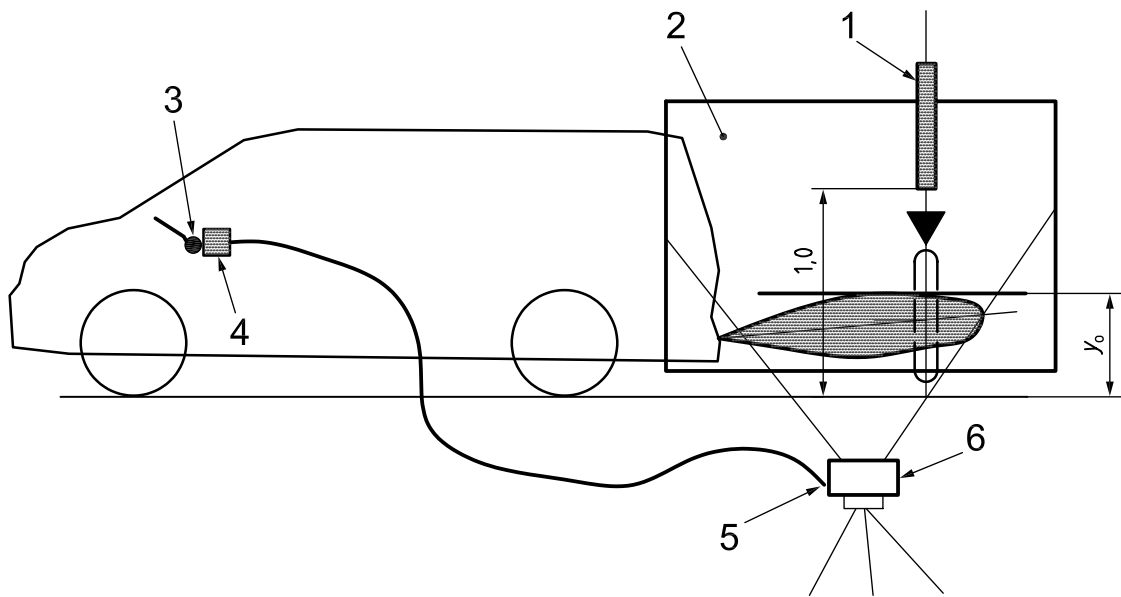

Key

- 1 test target
- 2 view of the video camera
- 3 audible warning emitter
- 4 microphone
- 5 sound input
- 6 video camera

Figure A.1 — Example of test setup for system reaction time

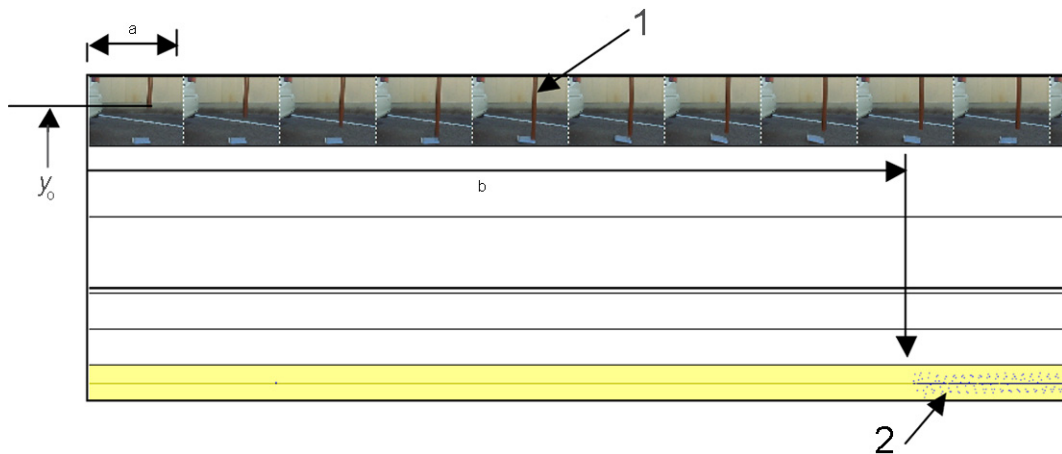

Key

- 1 test target
 - 2 sound of audible warning
- a 1 frame = 33 ms.
 b 8 frames = 264 ms.

NOTE The time delay is 264 ms with an accuracy of approximately 33 ms.

Figure A.2 — Example of a test result

Another version of this test method with reasonable cost and high accuracy uses a similar test setup, but an electronic stopwatch, instead of the video camera, is used.

The stopwatch is triggered by a light barrier to start the measurement. The light barrier is installed at the height position, y_0 , in order to start the measurement when the test target enters the detection zone. A microphone, which is placed at the driver's position in the car or in close proximity to the sound emitter of the MALSO system, is used to stop the stopwatch as soon as the system starts the acoustical alert. Care should be taken that no other sounds that would stop the watch are picked up by the microphone, e.g. when the object slams on to the ground.

Bibliography

- [1] ISO/TR 12155, *Commercial vehicles — Obstacle detection device during reversing — Requirements and tests*

