

---

---

## Safety footwear with resistance to chain saw cutting

*Chaussures de sécurité résistantes aux coupures de scie à chaîne*



Reference number  
ISO 17249:2013(E)

© ISO 2013



**COPYRIGHT PROTECTED DOCUMENT**

© ISO 2013

All rights reserved. Unless otherwise specified, no part of this publication may be reproduced or utilized otherwise in any form or by any means, electronic or mechanical, including photocopying, or posting on the internet or an intranet, without prior written permission. Permission can be requested from either ISO at the address below or ISO's member body in the country of the requester.

ISO copyright office  
Case postale 56 • CH-1211 Geneva 20  
Tel. + 41 22 749 01 11  
Fax + 41 22 749 09 47  
E-mail [copyright@iso.org](mailto:copyright@iso.org)  
Web [www.iso.org](http://www.iso.org)

Published in Switzerland

# Contents

	Page
Foreword .....	iv
<b>1 Scope .....</b>	<b>1</b>
<b>2 Normative references .....</b>	<b>1</b>
<b>3 Terms and definitions .....</b>	<b>1</b>
<b>4 Sampling and conditioning .....</b>	<b>2</b>
<b>5 Classification .....</b>	<b>2</b>
<b>6 Requirements .....</b>	<b>3</b>
6.1 General .....	3
6.2 Design .....	7
6.3 Construction .....	8
6.4 Resistance to chain saw cutting .....	9
<b>7 Marking .....</b>	<b>9</b>
<b>8 Information to be supplied .....</b>	<b>10</b>
8.1 General .....	10
8.2 Protection against chain saw cutting .....	11
8.3 Penetration resistance .....	11
8.4 Antistatic footwear .....	11
8.5 Insocks .....	12
<b>Annex A (informative) Assessment of the footwear by the wearer .....</b>	<b>13</b>
<b>Bibliography .....</b>	<b>16</b>

## Foreword

ISO (the International Organization for Standardization) is a worldwide federation of national standards bodies (ISO member bodies). The work of preparing International Standards is normally carried out through ISO technical committees. Each member body interested in a subject for which a technical committee has been established has the right to be represented on that committee. International organizations, governmental and non-governmental, in liaison with ISO, also take part in the work. ISO collaborates closely with the International Electrotechnical Commission (IEC) on all matters of electrotechnical standardization.

The procedures used to develop this document and those intended for its further maintenance are described in the ISO/IEC Directives, Part 1. In particular the different approval criteria needed for the different types of ISO documents should be noted. This document was drafted in accordance with the editorial rules of the ISO/IEC Directives, Part 2. [www.iso.org/directives](http://www.iso.org/directives)

Attention is drawn to the possibility that some of the elements of this document may be the subject of patent rights. ISO shall not be held responsible for identifying any or all such patent rights. Details of any patent rights identified during the development of the document will be in the Introduction and/or on the ISO list of patent declarations received. [www.iso.org/patents](http://www.iso.org/patents)

Any trade name used in this document is information given for the convenience of users and does not constitute an endorsement.

The committee responsible for this document is ISO/TC 94, *Personal safety — Protective clothing and equipment*, Subcommittee SC 3, *Foot protection*.

This second edition cancels and replaces the first edition (ISO 17249:2004) which has been technically revised. It also incorporates the Amendment ISO 17249:2004/Amd 1:2007.

# Safety footwear with resistance to chain saw cutting

## 1 Scope

This International Standard specifies requirements for safety footwear with resistance to chain saw cutting.

## 2 Normative references

The following documents, in whole or in part, are normatively referenced in this document and are indispensable for its application. For dated references, only the edition cited applies. For undated references, the latest edition of the referenced document (including any amendments) applies.

ISO 20344:2011, *Personal protective equipment — Test methods for footwear*

ISO 20345:2011, *Personal protective equipment — Safety footwear*

EN 381-3, *Protective clothing for users of hand-held chain-saws — Part 3: Test methods for footwear*

EN 50321, *Electrically insulating footwear for working on low voltage installations*

## 3 Terms and definitions

For the purposes of this document, the terms and definitions given in ISO 20345 and the following apply.

### 3.1

#### **feather line**

line around the inside of the footwear where the foot enclosure turns from vertical to horizontal

Note 1 to entry: This is not ordinarily the same as the insole edge or sole edge. See [Figure 1](#).

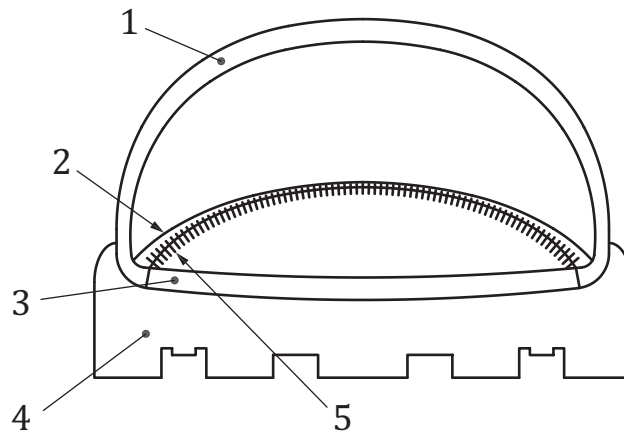

**Key**

- 1 upper
- 2 feather line
- 3 insole
- 4 outsole
- 5 Strobel stitching

**Figure 1 — Position of the feather line**

**4 Sampling and conditioning**

The minimum number of samples shall be that specified in ISO 20344:2011, Table 1, for general test methods and [Clause 6](#) for job-related test methods.

All test pieces shall be conditioned in a standard atmosphere of  $(23 \pm 2) \text{ }^\circ\text{C}$  and  $(50 \pm 5) \%$  relative humidity for a minimum of 48 h before testing, unless otherwise stated in the test method.

The maximum time which shall elapse between removal from the conditioning atmosphere and the start of testing shall be not greater than 10 min, unless otherwise stated in the test method.

Each test piece shall individually satisfy the specific requirement, unless otherwise stated in the test method.

The uncertainty of measurement for each test method described in this International Standard shall be assessed. One of the two following approaches shall be used:

- a statistical method, e.g. that given in ISO 5725-2;[\[1\]](#)
- a mathematical method, e.g. that given in ENV 13005.[\[3\]](#)

**5 Classification**

Safety footwear with resistance to chain saw cutting shall be classified in accordance with ISO 20345:2011, Table 1.

## 6 Requirements

### 6.1 General

Three levels of performance (see [Table 4](#)) of safety footwear with varying resistance to chain saw cutting are specified according to the different chain saw speeds.

Safety footwear with resistance to chain saw cutting shall conform to the requirements given in [Tables 1, 2, 3](#) and [4](#).

**Table 1 — Requirements**

	Requirement	Reference		Classification		Symbol
		ISO 20345:2011	This International Standard	I	II	
Design	Height of upper	5.2.1		X	X	
	Seat region	5.2.2		X	X	
	Design		6.2	X	X	
	Construction		6.3	X	X	

NOTE The applicability of a requirement to a particular classification is indicated in this Table by the following:

X The requirement shall be met. In some cases the requirement relates only to particular materials within the classification — e.g. pH value of leather components. This does not mean that other materials are precluded from use.

O If the component part exists, the requirement shall be met. The absence of X or O indicates that there is no requirement.

<sup>a</sup> If the property is claimed, the requirement given in the appropriate clause shall be met.

Table 1 (continued)

	Requirement	Reference		Classification		Symbol
		ISO 20345:2011	This International Standard	I	II	
Whole footwear	Sole performance:	5.3.1				
	Construction	5.3.1.1		X		
	Upper/outsole bond strength	5.3.1.2		X		
	Toe protection:	5.3.2				
	General	5.3.2.1		X	X	
	Internal length of toecaps	5.3.2.2		X	X	
	Impact resistance	5.3.2.3		X	X	
	Compression resistance	5.3.2.4		X	X	
	Behaviour of toecaps	5.3.2.5		X	X	
	Leak proofness	5.3.3			X	
	Specific ergonomic features	5.3.4		X	X	
	Slip resistance	5.3.5		a	a	SRA SRB SRC
	Penetration resistance	6.2.1		O	O	P
	Electrical properties:	6.2.2				
	Antistatic footwear	6.2.2.2		a	a	A
	Electrically insulating footwear	6.2.2.3		a	a	See EN 50321
	Resistance to inimical environments:	6.2.3				
	Heat insulation of sole complex	6.2.3.1		a	a	HI
	Cold insulation of sole complex	6.2.3.2		a	a	CI
	Energy absorption of seat region	6.2.4		a	a	E
	Water resistance	6.2.5		a		WR
	metatarsal protection	6.2.6		a	a	M
	Ankle protection	6.2.7		a	a	AN
Resistance to chain saw cutting		6.4	X	X		

NOTE The applicability of a requirement to a particular classification is indicated in this Table by the following:

X The requirement shall be met. In some cases the requirement relates only to particular materials within the classification — e.g. pH value of leather components. This does not mean that other materials are precluded from use.

O If the component part exists, the requirement shall be met. The absence of X or O indicates that there is no requirement.

a If the property is claimed, the requirement given in the appropriate clause shall be met.



Table 1 (continued)

	Requirement	Reference		Classification		Symbol
		ISO 20345:2011	This International Standard	I	II	
Upper	General	5.4.1		X	X	
	Thickness	5.4.2			X	
	Tear strength	5.4.3		X		
	Tensile properties	5.4.4		X	X	
	Flexing resistance	5.4.5			X	
	Water vapour permeability and coefficient	5.4.6		X		
	pH value	5.4.7		X		
	Hydrolysis	5.4.8			X	
	Chromium VI content	5.4.9		X		
	Water penetration and water absorption	6.3.1		a		WRU
	Upper construction	6.3.2		X		
Cut resistance	6.3.3		a	a	CR	
Vamp lining	Tear strength	5.5.1		X		
	Abrasion resistance	5.5.2		X		
	Water vapour permeability and coefficient	5.5.3		X		
	pH value	5.5.4		X		
	Chromium VI content	5.5.5		X		
Quarter lining	Tear strength	5.5.1		O		
	Abrasion resistance	5.5.2		O		
	Water vapour permeability and coefficient	5.5.3		O		
	pH value	5.5.4		O		
	Chromium VI content	5.5.5		O		
Tongue	Tear strength	5.6.1		O		
	pH value	5.6.2		O		
	Chromium VI content	5.6.3		O		

NOTE The applicability of a requirement to a particular classification is indicated in this Table by the following:  
X The requirement shall be met. In some cases the requirement relates only to particular materials within the classification — e.g. pH value of leather components. This does not mean that other materials are precluded from use.  
O If the component part exists, the requirement shall be met. The absence of X or O indicates that there is no requirement.  
a If the property is claimed, the requirement given in the appropriate clause shall be met.

**Table 1** (continued)

	Requirement	Reference		Classification		Symbol
		ISO 20345:2011	This International Standard	I	II	
Outsole	Thickness	5.8.1		X	X	
	Tear strength	5.8.2		X		
	Abrasion resistance	5.8.3		X	X	
	Flexing resistance	5.8.4		X	X	
	Hydrolysis	5.8.5		X	X	
	Interlayer bond strength	5.8.6		O	O	
	Resistance to fuel oil	5.8.7		a	a	FO
	Cleated area	6.4.1		X	X	
	Thickness of cleated outsoles	6.4.2		X	X	
	Cleat height	6.4.3		X	X	
	Resistance to hot contact	6.4.4		a	a	HRO

NOTE The applicability of a requirement to a particular classification is indicated in this Table by the following:

X The requirement shall be met. In some cases the requirement relates only to particular materials within the classification — e.g. pH value of leather components. This does not mean that other materials are precluded from use.

O If the component part exists, the requirement shall be met. The absence of X or O indicates that there is no requirement.

a If the property is claimed, the requirement given in the appropriate clause shall be met.

Table 2 — Basic requirements for insoles and/or insocks

Options			Component to be assessed	Requirements of ISO 20345:2011 to fulfil						
				Thick-ness 5.7.1	pH <sup>a</sup> 5.7.2	Water absorption, desorption 5.7.3	Insole abrasion 5.7.4.1	Chromium VI <sup>a</sup> 5.7.5	Insock abrasion 5.7.4.2	
1	No insole or, if present, not fulfilling the requirements	Non-removable insock	Insock	X	X	X		X	X	
2	Insole present	No insock	Insole	X	X	X	X	X		
3		Seat sock present								
4		Full insock, non-removable	Insock and insole together	X		X				
5		Full insock, removable and water permeable <sup>b</sup>	Insole	X	X	X	X	X	X	
	Insock			X				X	X	
		Full insock, removable, not water permeable <sup>b</sup>	Insole	X	X	X	X	X		
			Insock		X	X		X	X	

X The requirement shall be met.

<sup>a</sup> Those requirements are only for leather.

<sup>b</sup> A water permeable insock is one that, when tested in accordance with ISO 20344:2011, 7.2, lets water through in 60 s or less.

## 6.2 Design

The minimum height, *l*, of the protective area (see [Figure 1](#)) shall be in accordance with [Table 3](#). At least 3 sizes shall be checked (smallest, largest and intermediate). The right and left footwear shall be checked.

No point of the top of the upper shall be lower than the minimum height, *l*, of the protective area (see [Figure 1](#) and [Table 3](#)).

Table 3 — Minimum height of the top of the protective area

Footwear size		Minimum height <i>l</i> (mm)
French	English	
36 and below	Up to 3 ½	162
37 and 38	4 to 5	165
39 and 40	5 ½ to 6 ½	172
41 and 42	7 to 8	178
43 and 44	8 ½ to 10	185
45 and above	10 ½ and above	192

6.3 Construction

At least 3 sizes shall be checked (smallest, largest and intermediate). The right and left footwear shall be checked.

Safety footwear with resistance to chain saw cutting shall have a continuous protective area, as shown in [Figure 2](#), comprising the vamp, tongue and toe area of the footwear. It includes:

- a) the safety toecap;
- b) the area immediately behind the toecap back edge bounded by two vertical lines at least 70 mm on either side of the footwear centre line, measured between point A and point B as shown in [Figure 2](#), and a line parallel to the feather line at a maximum distance of 10 mm above the feather line and with a minimum height as given in [Table 3](#); each protected area of the closed footwear shall be checked.

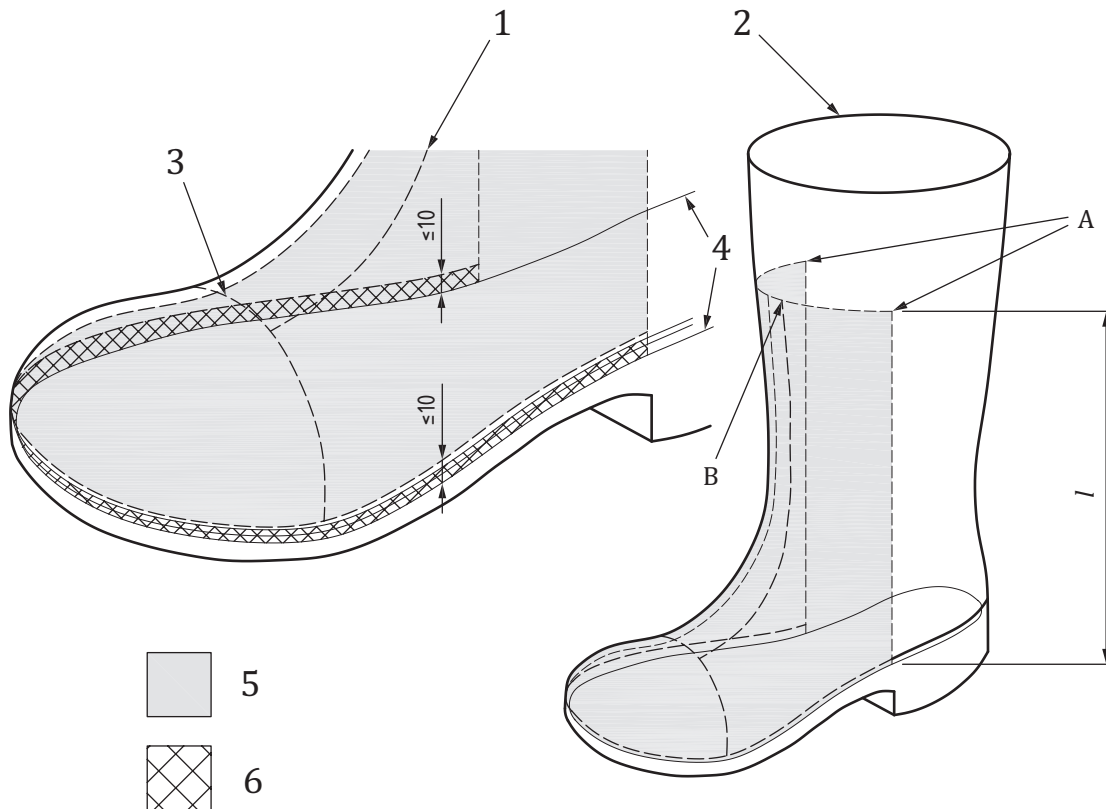

Key

- 1 footwear centre line
- 2 top of upper
- 3 toecap back edge
- 4 feather line
- 5 protective area
- 6 additional protective area for level 3 footwear

Figure 2 — Minimum protective area

For level 3 footwear (see [6.4](#)), there shall be no gap between the protective area and the feather line.

There shall be no gap between the toecap and the protective material.

All chain saw protective material shall be permanently attached to the footwear. If different chain saw protective materials are used, they shall either be butted together or overlapped so that there are no surface gaps.

Each protective area shall be tested if difference in composition is detected.

If the footwear is designed to provide performance over a larger area than that specified, all parts shall have the same protective quality.

#### 6.4 Resistance to chain saw cutting

When tested in accordance with the method described in EN 381-3, using the test chain speed specified in [Table 4](#) for the appropriate level of performance of footwear, no cut-through shall occur.

For footwear with non-steel toe caps, a chain saw cut test on the toe area of the footwear shall be done.

NOTE During the set-up procedure the footwear can be covered by a suitable protection in order to avoid surface contamination.

**Table 4 — Levels of performance**

Levels of performance	Chain speed (m/s)
1	20
2	24
3	28

## 7 Marking

Each item of safety footwear with resistance to chain saw cutting shall be clearly and permanently marked, for example by embossing or branding, with the following:

- a) size;
- b) manufacturer's identification mark;
- c) manufacturer's type designation;
- d) year and at least quarter of manufacture;
- e) the number and year of this International Standard, i.e. ISO 17249:2013;
- f) the symbol(s) from [Table 1](#) appropriate to the protection provided which is/are not covered by the pictogram (see [Figure 3](#)).

In addition, the pictogram shown in [Figure 3](#), together with the level of performance provided (level 1, level 2 or level 3), shall be given on a label of dimensions at least 30 mm x 30 mm attached in a visible position on the outside of the footwear.

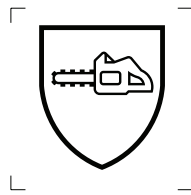

Level X

**Key**

X level of performance (see 6.4)

**Figure 3 — Pictogram indicating protection against chain saw cutting (symbol ISO 7000-2416)**

## 8 Information to be supplied

### 8.1 General

Safety footwear with resistance to chain saw cutting shall be supplied to the customer with information written at least in the official language(s) of the state of destination. All information shall be unambiguous. The following information shall be given.

- a) Name and full address of the manufacturer and/or his authorized representative.
- b) Notified body involved in type approval.
- c) Number and year of this International Standard.
- d) Explanation of any pictograms, markings and levels of performance. A basic explanation of the tests that have been applied to the footwear, if applicable.
- e) Instructions for use:
  - 1) tests to be carried out by the wearer before use, if required;
  - 2) fitting; how to put on and take off the footwear, if relevant;
  - 3) application; basic information on possible uses and, where detailed information is available, the source;
  - 4) limitations of use (e.g. temperature range);
  - 5) instructions for storage and maintenance, with maximum periods between maintenance checks (if important, drying procedures to be defined);
  - 6) instructions for cleaning and/or decontamination;
  - 7) obsolescence deadline or period of obsolescence;
  - 8) if appropriate, warnings against problems likely to be encountered (modifications can invalidate the type approval, e.g. for orthopaedic footwear);
  - 9) if helpful, additional illustrations, part numbers etc.
- f) Reference to accessories and spare parts, if relevant.
- g) The type of packaging suitable for transport, if relevant.

## 8.2 Protection against chain saw cutting

Each pair of safety footwear with resistance to chain saw cutting shall be supplied with a leaflet containing the substance of the following wording:

“No personal protective equipment can ensure 100 % protection against cutting from a hand held chain saw. Under laboratory conditions the tested chain saw cutting resistance is required for the front parts of the footwear (tongue and toe-cap area); even in these named areas cutting injuries are possible. Nevertheless, experience has shown that it is possible to design equipment which offers a certain degree of protection. Different functional principles, which may be applied in order to give protection, include:

- chain slipping on contact, such that it does not cut the material;
- clogging fibres drawn by the chain into the drive sprocket to block chain movement;
- chain braking by use of fibres with a high resistance to cutting which absorb kinetic energy, thereby reducing chain speed.

Often more than one principle is applied.

Three levels of performance are available, denoting different levels of chain saw resistance.

It is recommended to select the footwear in line with the chain saw speed.

It is important that there is an overlap between the protective material within the footwear and trousers.”

## 8.3 Penetration resistance

Each pair of safety footwear with resistance to penetration shall be supplied with a leaflet containing the following wording.

“The penetration resistance of this footwear has been measured in the laboratory using a truncated nail of diameter 4,5 mm and a force of 1 100 N. Higher forces of nails of smaller diameter will increase the risk of penetration occurring. In such circumstances alternative preventative measures should be considered.”

## 8.4 Antistatic footwear

Each pair of antistatic footwear shall be supplied with a leaflet containing the following wording.

“Antistatic footwear should be used if it is necessary to minimize electrostatic build-up by dissipating electrostatic charges, thus avoiding the risk of spark ignition of, for example flammable substances and vapours, and if the risk of electric shock from any electrical apparatus or live parts has not been completely eliminated. It should be noted, however, that antistatic footwear cannot guarantee an adequate protection against electric shock as it introduces only a resistance between foot and floor. If the risk of electric shock has not been completely eliminated, additional measures to avoid this risk are essential. Such measures, as well as the additional tests mentioned below, should be a routine part of the accident prevention programme at the workplace.

Experience has shown that, for antistatic purposes, the discharge path through a product should normally have an electrical resistance of less than 1 000 M $\Omega$  at any time throughout its useful life. A value of 100 k $\Omega$  is specified as the lowest limit of resistance of a product when new, in order to ensure some limited protection against dangerous electric shock or ignition in the event of any electrical apparatus becoming defective when operating at voltages of up to 250 V. However, under certain conditions, users should be aware that the footwear might give inadequate protection and additional provisions to protect the wearer should be taken at all times.

The electrical resistance of this type of footwear can be changed significantly by flexing, contamination or moisture. This footwear will not perform its intended function if worn in wet conditions. It is, therefore, necessary to ensure that the product is capable of fulfilling its designed function of dissipating electrostatic charges and also of giving some protection during the whole of its life. The user is recommended to establish an in-house test for electrical resistance and use it at regular and frequent intervals.

Classification I footwear can absorb moisture if worn for prolonged periods, and in moist and wet conditions can become conductive.

If the footwear is worn in conditions where the soling material becomes contaminated, wearers should always check the electrical properties of the footwear before entering a hazard area.

Where antistatic footwear is in use, the resistance of the flooring should be such that it does not invalidate the protection provided by the footwear.

In use, no insulating elements, with the exception of normal hose, should be introduced between the inner sole of the footwear and the foot of the wearer. If any insert is put between the inner sole and the foot, the combination footwear/insert should be checked for its electrical properties”.

### 8.5 Insocks

If the footwear is supplied with a removable insock it should be made clear that testing was carried out with the insock in place. A warning shall be given that the footwear shall only be used with the insock in place and that the insock shall only be replaced by a comparable insock supplied by the original footwear manufacturer.

If the footwear is supplied without an insock it should be made clear that testing was carried out with no insock present. A warning shall be given that fitting an insock can affect the protective properties of the footwear.

.....



## Annex A (informative)

### Assessment of the footwear by the wearer

#### A.1 General

The following list and figures can be provided to assist in assessing the performance of safety footwear with resistance to chain saw cutting. This information is provided as a guide and not as a complete list.

#### A.2 Criteria for the assessment of the state of footwear

Chain saw cut resistant footwear should be assessed at regular intervals, but at least before each use, by inspection and should be replaced when any of the signs of wear identified below are found (some of these criteria can vary according to the type of footwear and materials used):

- beginning of pronounced and deep cracking affecting half of the upper material thickness [Figure A.1 a)];
- strong abrasion of the upper material, especially if the toecap is revealed [Figure A.1b)];
- split seams or damage caused by contact, e.g. with the chainsaw [Figure A.1c)];
- the outsole shows cracks higher than 10 mm long and 3 mm deep [Figure A.1d)]; upper/sole separation of more than 10 mm to 15 mm long and 5 mm wide (deep);
- cleat height in the flexing area lower than 1,5 mm [Figure A.1e)];
- original insock (if any) showing pronounced deformation and crushing.

It is convenient to check:

- the inside of the footwear manually from time to time, aiming at detecting destruction of the lining or sharp borders of the toe protection which could cause wounds [Figure A.1 f)];
- the closing mechanism is in working order (zip, laces, eyelets, touch and close system);
- the obsolescence deadline or period of obsolescence.

See [Figure A.1](#).

Dimensions in millimetres

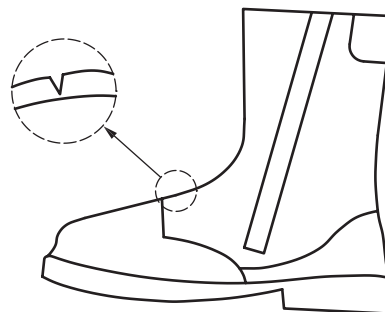

a)

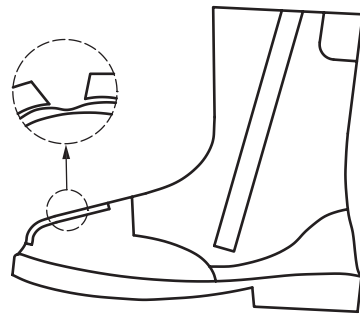

b)

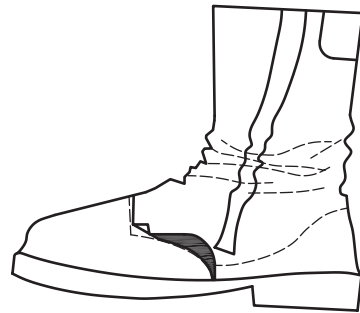

c)

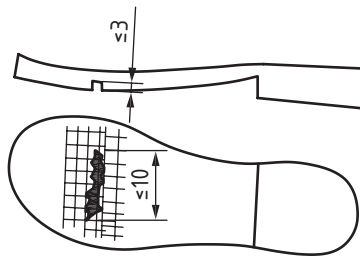

d)

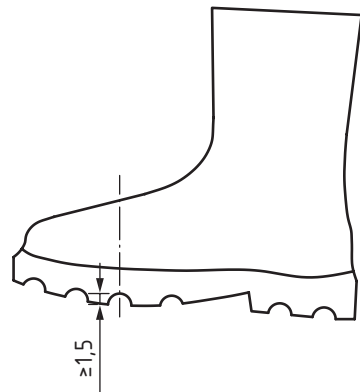

e)



f)

**Figure A.1 — Criteria for the assessment of the state of footwear with resistance to chain saw cutting**

## Bibliography

- [1] ISO 5725-2, *Accuracy (trueness and precision) of measurement methods and results — Part 2: Basic method for the determination of repeatability and reproducibility of a standard measurement method*
- [2] ISO 7000, *Graphical symbols for use on equipment — Registered symbols*
- [3] ENV 13005, *Guide to the uncertainty of measurement (GUM)*

Copyright International Organization for Standardization  
Provided by IHS under license with ISO  
No reproduction or networking permitted without license from IHS

