

First edition
2014-05-01

Plastics — Determination of yellowness index and change in yellowness index

*Plastiques — Détermination de l'indice de jaunissement et du
changement de l'indice de jaunissement*





COPYRIGHT PROTECTED DOCUMENT

© ISO 2014

All rights reserved. Unless otherwise specified, no part of this publication may be reproduced or utilized otherwise in any form or by any means, electronic or mechanical, including photocopying, or posting on the internet or an intranet, without prior written permission. Permission can be requested from either ISO at the address below or ISO's member body in the country of the requester.

ISO copyright office
Case postale 56 • CH-1211 Geneva 20
Tel. + 41 22 749 01 11
Fax + 41 22 749 09 47
E-mail copyright@iso.org
Web www.iso.org

Published in Switzerland

Contents

	Page
Foreword	iv
1 Scope	1
2 Normative references	1
3 Terms and definitions	1
4 Preparation and conditioning of samples and test specimens	2
4.1 Sample and preparation of test specimen.....	2
4.2 Environment of measurement and standard condition.....	2
5 Procedure	2
5.1 General.....	2
5.2 Transmission measurement method for sheet, film, moulded plaque, or disc specimens...	2
5.3 Reflection measurement method for sheet or film specimens.....	3
5.4 Reflection measurement method for pellet or powder specimens.....	3
5.5 Measurement requirements.....	4
6 Expression of results	5
6.1 Calculation procedure of yellowness index.....	5
6.2 Calculation procedure of change of yellowness index.....	6
6.3 Precision.....	6
7 Test report	9

Foreword

ISO (the International Organization for Standardization) is a worldwide federation of national standards bodies (ISO member bodies). The work of preparing International Standards is normally carried out through ISO technical committees. Each member body interested in a subject for which a technical committee has been established has the right to be represented on that committee. International organizations, governmental and non-governmental, in liaison with ISO, also take part in the work. ISO collaborates closely with the International Electrotechnical Commission (IEC) on all matters of electrotechnical standardization.

The procedures used to develop this document and those intended for its further maintenance are described in the ISO/IEC Directives, Part 1. In particular the different approval criteria needed for the different types of ISO documents should be noted. This document was drafted in accordance with the editorial rules of the ISO/IEC Directives, Part 2 (see www.iso.org/directives).

Attention is drawn to the possibility that some of the elements of this document may be the subject of patent rights. ISO shall not be held responsible for identifying any or all such patent rights. Details of any patent rights identified during the development of the document will be in the Introduction and/or on the ISO list of patent declarations received (see www.iso.org/patents).

Any trade name used in this document is information given for the convenience of users and does not constitute an endorsement.

For an explanation on the meaning of ISO specific terms and expressions related to conformity assessment, as well as information about ISO's adherence to the WTO principles in the Technical Barriers to Trade (TBT) see the following URL: Foreword - Supplementary information

The committee responsible for this document is ISO/TC 61, *Plastics*, Subcommittee SC 5, *Physical-chemical properties*.

Plastics — Determination of yellowness index and change in yellowness index

1 Scope

This International Standard specifies an instrumental method for determining the yellowness index and change in yellowness index on clear, translucent, or opaque plastics.

NOTE 1 Specimen shapes can include moulded plaques or discs, films, sheets, powders, and pellets. Plaque, disc, film, and sheet specimens can have smooth, matt, or patterned surfaces. Fluorescent plastics are not permitted.

NOTE 2 Change in yellowness index is often used to evaluate the effect of environment, e.g. heat, UV exposure, etc., on colour stability.

2 Normative references

The following documents, in whole or in part, are normatively referenced in this document and are indispensable for its application. For dated references, only the edition cited applies. For undated references, the latest edition of the referenced document (including any amendments) applies.

ISO 291, *Plastics — Standard atmospheres for conditioning and testing*

ISO 1043-1, *Plastics — Symbols and abbreviated terms — Part 1: Basic polymers and their special characteristics*

ISO 5725-2, *Accuracy (trueness and precision) of measurement methods and results — Part 2: Basic method for the determination of repeatability and reproducibility of a standard measurement method*

ASTM E313, *Standard Practice for Calculating Yellowness and Whiteness Indices from Instrumentally Measured Color Coordinates*

CIE 15, *Colorimetry*

3 Terms and definitions

For the purposes of this document, the following terms and definitions apply.

3.1

yellowness index

YI

deviation in chroma from colourless or whiteness toward yellow

3.2

change of yellowness index

ΔYI

difference between yellowness index of specimen before additional test and yellowness index of specimen after additional test

Note 1 to entry: For example, before and after exposure to specified conditions.

4 Preparation and conditioning of samples and test specimens

4.1 Sample and preparation of test specimen

Samples shall be gathered by a statistical method from the batch to be evaluated. In all cases, the sample shall be used as received unless the purpose is to evaluate pellets or powders converted into a final shape, i.e. moulded plaques or discs, films, or sheets.

4.2 Environment of measurement and standard condition

The standard condition of the environment of measurement shall be set as 23 °C/50 % RH condition as described in ISO 291.

5 Procedure

5.1 General

Colourimetry is derived from calculating tristimulus values by spectral or tristimulus measurements. In the case of the specimen with the diffusibility of the light, the measuring apparatus shall have an integrating sphere or other system that can detect diffusion light. Optical geometries, requirements, and solution for different measurement methods are given in [Table 1](#).

Table 1 — Optical geometries, requirements, and solution for different measurement methods

Measurement method using integrating sphere	Optical geometries in accordance with CIE 15	Requirements	Solution
Transmission measurements	di:0, de:0	A part of the incident light on the integrating sphere shall not irradiate a specimen directly.	Arrange a baffle plate that is the same quality as the integrating sphere.
Reflection measurement	di:8, de:8		
Transmission measurements	0:di, 0:de	A part of a reflected or transmitted light from a specimen shall not be introduced into a detector directly.	
Reflection measurement	8:di, 8:de		
Measurement method without integrating sphere	Optical geometries in accordance with CIE 15		
Transmission measurements	0:0	These optical geometries don't use an integrating sphere.	
Reflection measurement	45a:0, 0:45a, 45x:0, 0:45a		

NOTE 1 In the case of measuring a diffusing specimen, satisfying the above-mentioned condition is important.

NOTE 2 In the case of measuring a translucent specimen, the colour or thickness of the specimen might make an influence.

NOTE 3 Optical geometries are described in CIE 15.

Tristimulus values are represented in the XYZ colour system (2° visual field) or the $X_{10}Y_{10}Z_{10}$ colour system (10° visual field) using CIE standard illuminant D65 or supporting illuminant C.

One of the following three measurement methods specified in [5.2](#) to [5.4](#) shall be used.

5.2 Transmission measurement method for sheet, film, moulded plaque, or disc specimens

Adjust the centre of the specimen and the centre of the opening for measurement, and measure the tristimulus value (see [Figure 1](#)).

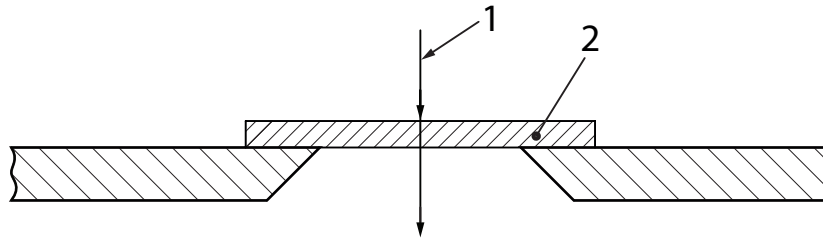
**Key**

- 1 incident light
- 2 specimen

Figure 1 — Transmission measurement method for sheet or film specimens

5.3 Reflection measurement method for sheet or film specimens

Adjust the centre of the specimen and the centre of the opening for measurement. Cover the specimen with a light trap and measure the tristimulus values (see [Figure 2](#)).

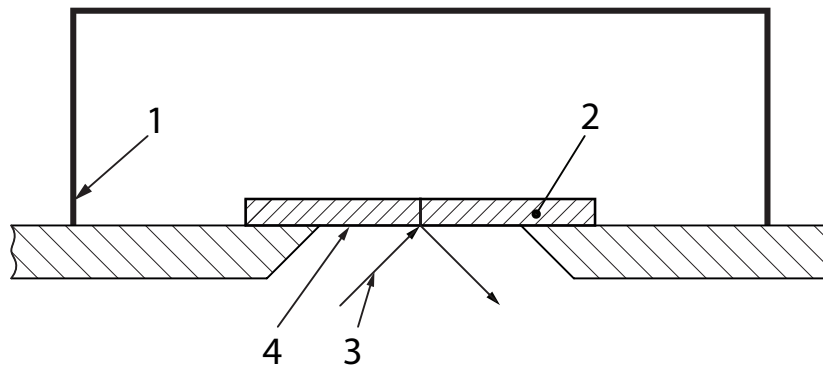
**Key**

- 1 light trap
- 2 specimen
- 3 incident light
- 4 measured surface

Figure 2 — Reflection measurement method for sheet or film specimen

In the case of using a backing plate on the back side of the specimen, the kind of the backing plate and its tristimulus values shall be reported.

5.4 Reflection measurement method for pellet or powder specimens

Pour the specimen into the cylinder-shaped container made of clear glass or quartz glass and measure the tristimulus values using the reflection method. The specimen container shall be covered with a light trap. The opening of the specimen container shall not be covered with a backing plate (see [Figure 3](#)).

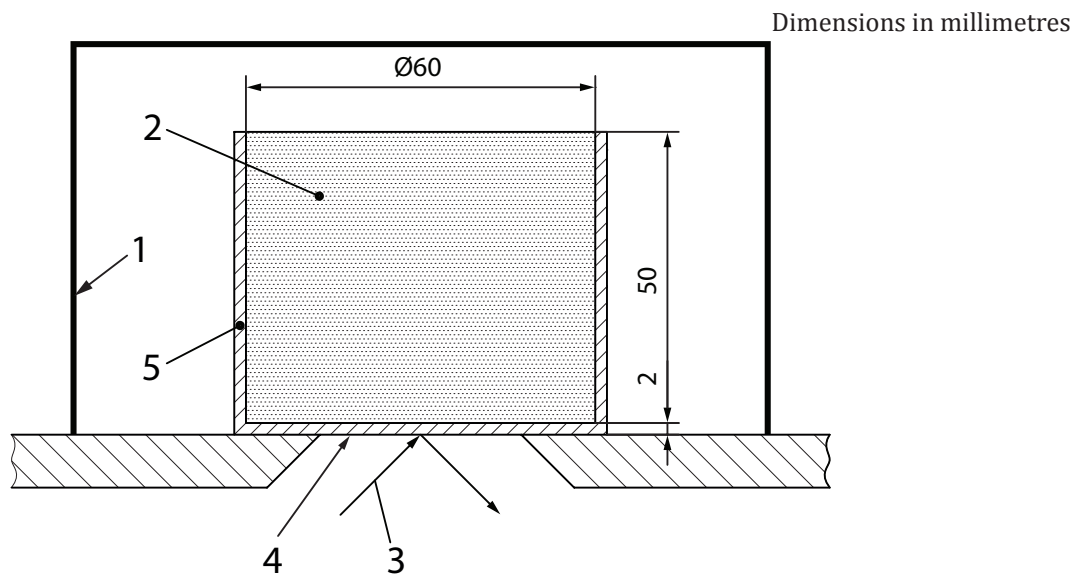

Key

- 1 light trap
- 2 specimen
- 3 incident light
- 4 measured surface
- 5 specimen container

Figure 3 — Example of reflection measurement method for pellet or powder specimen

NOTE 1 When pouring the pellet or powder specimen into the specimen container, shake or lightly tap the specimen container and remove surplus specimen using a smooth device such as a spatula.

NOTE 2 A preliminary examination of pellet specimen was achieved, but precision was not mentioned in the method of colourimetry and geometry described in CIE 15. It is supposed that the surface of specimen does not have high uniformity, depending on the shape and size of the pellet. It means it is difficult to compare measurements mutually. It is necessary to treat it for a relative value.

No pressure from the opening of the container shall be added.

For calibration of the instrument, one of the following methods shall be used.

- a) The working standard is put into the specimen container.
- b) The working standard is put on the glass that has the same quality and thickness as the specimen container.

5.5 Measurement requirements

5.5.1 Sheet, film, moulded plaque, or disc specimen

- a) Clear specimen

Clear specimens shall be measured using 0:0, di:0, de:0, 0:di, or 0:de geometry for transmission. Patterned or matt specimens shall be measured using di:0, de:0, 0:di, or 0:de geometry for transmission.

- b) Translucent white specimen

Translucent white specimens shall be measured using di:8, de:8, 8:di, 8:de, 45a:0, 0:45a, 45x:0, or 0:45x geometry for reflection, or using di:0, de:0, 0:di, or 0:de geometry for transmission.

NOTE 1 The measured value of a translucent white specimen has relatively low reproducibility.

NOTE 2 In the case of the method with integrating sphere, tristimulus values go down unless the specimen is adhered to an integrating sphere, and yellowness index changes.

NOTE 3 Optical geometries are described in CIE 15.

c) Opaque specimen

Opaque sheet or film specimens shall be measured using di:8, de:8, 8:di, 8:de, 45a:0, 0:45a, 45x:0, or 0:45x geometry for reflection.

5.5.2 Pellet or powder specimen

Pellet or powder specimens shall be measured using di:8, de:8, 8:di, 8:de, 45a:0, 0:45a, 45x:0, or 0:45x geometry for reflection.

6 Expression of results

6.1 Calculation procedure of yellowness index

The yellowness index is derived by Formulae (1) to (4) in accordance with ASTM E313.

Illuminant	Colour system		
CIE standard illuminant D65	XYZ	$YI = 100(1,298\ 5X - 1,133\ 5Z)/Y$	(1)
CIE standard illuminant D65	$X_{10}Y_{10}Z_{10}$	$YI = 100(1,301\ 3X_{10} - 1,149\ 8Z_{10})/Y_{10}$	(2)
supporting illuminant C	XYZ	$YI = 100(1,276\ 9X - 1,059\ 2Z)/Y$	(3)
supporting illuminant C	$X_{10}Y_{10}Z_{10}$	$YI = 100(1,287\ 1X_{10} - 1,078\ 1Z_{10})/Y_{10}$	(4)

where

YI is the yellowness index;

X, Y, Z are the tristimulus values in the XYZ colour system using CIE standard illuminant D65 or supporting illuminant C;

X_{10}, Y_{10}, Z_{10} are the tristimulus values in the $X_{10}Y_{10}Z_{10}$ colour system using CIE standard illuminant D65 or supporting illuminant C.

6.2 Calculation procedure of change of yellowness index

The change of yellowness index is derived by Formula (5).

$$\Delta YI = YI - YI_0 \quad (5)$$

where

- ΔYI is the change of yellowness index;
- YI is the yellowness index after test;
- YI_0 is the yellowness index before test.

NOTE In case ΔYI is a positive value, it means yellowness increased.

6.3 Precision

6.3.1 Precision of film and sheet specimen

An interlaboratory trial was achieved in Japan. Results of repeatability s_r and reproducibility s_R in the joint experiment based on ISO 5725-2 are shown in [Table 2](#) and [Table 3](#). In the case of calculating precision, the Cochran method and the Grubbs method based on ISO 5725-2 are used, and the outlier value is excluded.

Transmission measurements are achieved in four laboratories, 11 materials.

Reflection measurements are achieved in five laboratories, five materials.

An international interlaboratory trial can or should replace the result.

Table 2 — Precision in transmission measurement using sheet specimens

No.	Material ^a	Colour	Diffuser	Surface	Thickness mm	Incident surface	YI (overall average) m	Repeatability s_r	Reproducibility s_R	Precision comparison ^b s_R/s_r
1	PMMA	Clear	None	Flat/Flat	3		0,45	0,02	0,09	6
2	PVC	Clear	None	Flat/Flat	2		-3,03	0,05	0,16	3
3	PC	Clear	None	Flat/Flat	5		-0,29	0,02	0,22	10
4	PMMA	Translucent white	Include	Flat/Flat	3		4,58	0,03	2,07	64
5	PMMA	Translucent white	Include	Flat/Flat	2		7,22	0,06	1,58	26
6	PMMA	Translucent white	Include	Flat/Flat	3		7,91	0,05	1,69	37
7	PMMA	Translucent white	Include	Flat/Flat	5		11,06	0,20	1,89	10
8	PMMA	Clear	None	Matt/Flat	3	Matt surface	0,33	0,02	0,21	11
9	PMMA	Clear	None	Matt/Matt	3		0,03	0,02	0,26	17
10	PS	Clear	None	Matt/ Pattern	3	Patterned surface	0,39	0,26	0,79	3
11	PMMA	Translucent white	Include	Matt/Flat	3	Matt surface	3,70	0,05	1,94	37

NOTE 1 From this result, repeatability values are below 0,2, except specimen No. 10. This implies a good level of repeatability. In the case of a specimen that has a patterned surface, the measured light intensity is dependent on the positioning of the specimen.

NOTE 2 The reproducibility is considered poor, in the 0,1 to 2,1 ranges, and independent of the overall average. This implies it is hard to use this measurement when good reproducibility is required. It is considered that the poor reproducibility was due to differences in geometry between these laboratories.

NOTE 3 On this transmission measurement, four laboratories participated for all 11 materials.

^a Symbols of materials are based on ISO 1043-1.

^b Precision comparisons, s_R/s_r , are usually below 3. But on this joint experiment, precision comparisons are relatively high.

Table 3 — Precision in reflection measurement using sheet specimen

No.	Material	Colour	Diffuser	Surface	Thickness mm	Incident surface	YI (overall average) m	Repeatability s_r	Reproducibility s_R	Precision comparison ^a s_R/s_r
4	PMMA	Translucent white	Include	Flat/Flat	3		-14,99	0,05	6,53	129
5	PMMA	Translucent white	Include	Flat/Flat	2		-3,79	0,02	1,61	66
6	PMMA	Translucent white	Include	Flat/Flat	3		-2,89	0,03	1,39	46
7	PMMA	Translucent white	Include	Flat/Flat	5		1,25	0,03	0,72	23
11	PMMA	Translucent white	Include	Matt/ Flat	3	Matt surface	-12,32	0,08	5,38	67

NOTE 1 From this result, repeatability values are below 0,1. It implies a good level of repeatability.

NOTE 2 The reproducibility tends to increase in proportion to the absolute value of the overall average. This implies that it is hard to use this measurement when high reproducibility is required. It is considered that the poor reproducibility is dependent on the different geometries used in these laboratories.

NOTE 3 On this reflection measurement, five laboratories participated for all five materials.

^a Precision comparisons, s_R/s_r , are usually below 3. But on this joint experiment, precision comparisons are relatively high.

6.3.2 Precision of pellet and powder specimen

A preliminary examination of pellet specimen was achieved, but precision was not mentioned in the method of colourimetry and geometry described in CIE 15. It is supposed that the surface of specimen does not have high uniformity, depending on the shape and size of the pellet. It means it is difficult to compare measurements mutually. It is necessary to treat it for a relative value.

Precision of powder will be described after a joint experiment is achieved.

7 Test report

The test report shall include at least the following:

- a) the name, type, thickness, and shape of specimens, i.e. for example for powder specimen, its grain size, and for pellet specimen, its shape, size, and appearance;
- b) the illuminant and colour system, which was used for the measurement;
- c) transmission or reflection;
- d) geometry;
- e) the direction of the specimen, if the specimen has a different surface;
- f) the yellowness index or change of yellowness index;
- g) the tristimulus values in transmission or reflection;
- h) the yellowness index before exposure test, if the change of yellowness index is expressed;
- i) the name and model of the apparatus;
- j) the tristimulus value of the backing plate, if applicable;
- k) the shape and size of the specimen container, if powder or pellet specimen was measured.

ICS 83.080.01

Price based on 9 pages

© ISO 2014 – All rights reserved

Copyright International Organization for Standardization
Not for Resale, 05/13/2014 23:03:22 MDT

Provided by IHS under license with ISO

Licensee=University of Alberta/5966844001, User=sharabiani, shahramfs