**Fine ceramics (advanced ceramics,
advanced technical ceramics) —
Determination of compaction
properties of ceramic powders**

*Céramiques techniques — Détermination des propriétés de
compactage des poudres céramiques*





COPYRIGHT PROTECTED DOCUMENT

© ISO 2014

All rights reserved. Unless otherwise specified, no part of this publication may be reproduced or utilized otherwise in any form or by any means, electronic or mechanical, including photocopying, or posting on the internet or an intranet, without prior written permission. Permission can be requested from either ISO at the address below or ISO's member body in the country of the requester.

ISO copyright office
Case postale 56 • CH-1211 Geneva 20
Tel. + 41 22 749 01 11
Fax + 41 22 749 09 47
E-mail copyright@iso.org
Web www.iso.org

Published in Switzerland

Contents

	Page
Foreword	iv
1 Scope	1
2 Normative references	1
3 Principle	1
4 Symbols and designation	1
5 Apparatus	1
6 Sampling	2
7 Procedure	2
7.1 Quantity.....	2
7.2 Cleaning of die and punches.....	2
7.3 Powder testing conditions.....	2
7.4 Lubrication.....	3
7.5 Compaction and ejection.....	3
7.6 Compaction pressures.....	4
8 Expression of results	4
8.1 Calculation.....	4
8.2 Compaction curve.....	4
9 Test report	4
Bibliography	8

Foreword

ISO (the International Organization for Standardization) is a worldwide federation of national standards bodies (ISO member bodies). The work of preparing International Standards is normally carried out through ISO technical committees. Each member body interested in a subject for which a technical committee has been established has the right to be represented on that committee. International organizations, governmental and non-governmental, in liaison with ISO, also take part in the work. ISO collaborates closely with the International Electrotechnical Commission (IEC) on all matters of electrotechnical standardization.

The procedures used to develop this document and those intended for its further maintenance are described in the ISO/IEC Directives, Part 1. In particular the different approval criteria needed for the different types of ISO documents should be noted. This document was drafted in accordance with the editorial rules of the ISO/IEC Directives, Part 2 (see www.iso.org/directives).

Attention is drawn to the possibility that some of the elements of this document may be the subject of patent rights. ISO shall not be held responsible for identifying any or all such patent rights. Details of any patent rights identified during the development of the document will be in the Introduction and/or on the ISO list of patent declarations received (see www.iso.org/patents).

Any trade name used in this document is information given for the convenience of users and does not constitute an endorsement.

For an explanation on the meaning of ISO specific terms and expressions related to conformity assessment, as well as information about ISO's adherence to the WTO principles in the Technical Barriers to Trade (TBT) see the following URL: Foreword - Supplementary information

The committee responsible for this document is ISO/TC 206, *Fine ceramics*.

Fine ceramics (advanced ceramics, advanced technical ceramics) — Determination of compaction properties of ceramic powders

1 Scope

This International Standard specifies the test method to determine the extent to which granulated or ungranulated ceramic powders are compacted, when subjected to uniaxial compressive loading in a confining die, under specified conditions.

2 Normative references

The following documents, in whole or in part, are normatively referenced in this document and are indispensable for its application. For dated references, only the edition cited applies. For undated references, the latest edition of the referenced document (including any amendments) applies.

ISO/IEC 17025, *General requirements for the competence of testing and calibration laboratories*

3 Principle

Granulated or ungranulated ceramic powders are compacted uniaxially in a confining die by double-action pressing (mode 1) or by single-action pressing (mode 2). Samples of the ceramic powders can be pressed either at a single specified pressure or at a series of specified pressures. After ejection from die, the apparent density of the ceramic powder compact is determined.

The apparent density obtained in the former case represents the compaction properties of the ceramic powder at the specified pressure. The apparent densities obtained in the latter case are utilized for drawing the compaction curve of the ceramic powder, which is a plot of apparent density as a function of compaction pressure.

4 Symbols and designation

Symbol	Designation	Unit
ρ_a	Apparent density	g/cm ³
m	Mass of ceramic powder compact	g
V	Volume of ceramic powder compact	cm ³

If the apparent density is measured at only one specified pressure, for example 100 MPa, the symbol becomes $\rho_a(100)$.

5 Apparatus

5.1 Cylindrical die, should be made from hard material, preferably hardened steel or tungsten carbide.

The die shall contain two upper and lower punches for producing cylindrical powder compacts and shall be of the floating type or of the type suspended from a spring (mode 1), or of stationary type with only one movable upper punch (mode 2). The die shall be capable of making cylindrical powder compacts with a diameter from 10 mm to 26 mm and a height to diameter ratio between 0,3 and 0,5 (mode 1), or with a diameter from 10 mm to 32 mm and a height to diameter ratio between 0,15 and 0,25 (mode 2).

2), as indicated in [Figure 1](#). The upper part of the die shall be preferably designed to avoid damage to the powder compact during ejection due to spring-back. An ejection cone of height 5 mm, allowing an increase of the diameter at the top of the die of approximately 1 %, as shown in [Figure 1](#), should be used.

5.2 Press, capable of applying sufficient force with a precision of ± 2 %.

5.3 Balance, capable of weighing at least 10 g with a resolution of $\pm 0,001$ g.

5.4 Micrometer, or other suitable measuring device for measuring the dimensions of ceramic powder compacts with a resolution of $\pm 0,01$ mm.

6 Sampling

6.1 In general, the powder should be tested in the as-received condition. In certain instances, the powder can be dried. If the powder is required to be dried, it should be dried at $(110 \pm 5)^\circ\text{C}$ for at least 24 h and cooled to room temperature in a desiccator until the test is performed. If the powder contains organic additives or volatile substances, it should not be dried.

6.2 Should there be any treatment (e.g. drying) of the powder before the test, it shall be recorded in the test report.

7 Procedure

7.1 Quantity

The quantity of the test sample shall be chosen to give the required number of powder compacts with dimensions as specified in [5.1](#). Per compaction pressure, three powder compacts shall be pressed (see [7.6](#)). If necessary, preliminary tests should be made in order to establish the quantity of powder which is needed for fulfilling this requirement.

7.2 Cleaning of die and punches

Wipe the die cavity and the punches, for example, with a soft clean paper towel soaked with an appropriate solvent such as acetone. Allow the solvent to evaporate.

7.3 Powder testing conditions

7.3.1 Powders which do not contain a lubricant shall be compacted either

a) in a dry die,

NOTE Seizure and excessive die wear can occur, particularly, at high compaction pressures.

b) in a die with lubricated walls (see [7.4.2](#)),

c) in a dry die, after mixing a lubricant with the powder (see [7.4.3](#)), and

d) in the as-received state.

7.3.2 Powders which contain a lubricant shall be compacted in a dry die.

7.4 Lubrication

7.4.1 Lubrication of the die walls or of the powder is likely to modify the compaction results. Similarly, depending on the type and the quantity of lubricant added to the powder, the results can vary within wide ranges. The test report (see [Clause 9](#)) shall therefore mention whether or not lubrication had taken place, and if the lubrication was carried out on the walls of the die or on the powder.

Use one of the following two methods (see [7.4.2](#) and [7.4.3](#)) if lubrication is applied.

7.4.2 In order to lubricate the die wall, apply a mixture or a solution of a lubricant in the volatile organic liquid, for example, 20 g of stearic acid in 980 g of acetone. After any excess liquid has been drained away, allow the solution adhering to the walls to evaporate leaving a thin layer of lubricant.

Alternatively, press inert spheres (for example, polyurethane spheres) coated with lubricant in the die before testing. After removal of the pressed disc of inert material, a thin layer of lubricant remains on the walls of the die.

7.4.3 Lubricate the powder to be tested by thoroughly mixing it with a quantity 0,1 wt% to 3,0 wt% of a suitable solid lubricant (for example, zinc stearate or stearic acid).

7.5 Compaction and ejection

7.5.1 Insert the lower punch into the die in order to leave a free volume in the die large enough to contain the ceramic powder [see [Figure 2\(a\)](#)].

7.5.2 Pour the powder into the die and level off to a uniform filling height [see [Figure 2\(a\)](#)].

7.5.3 Wipe the wall of the die to remove any powder that can adhere to it during filling of the die.

7.5.4 Insert the upper punch into the die [see [Figure 2\(b\)](#)].

7.5.5 Position the die with its upper and lower punches between the plate ends of the press. Apply and release a preliminary pressure. The pressure shall be lower than the lowest pressure used in the test.

Apply the selected test pressure and maintain for at least 10 s [see [Figure 2\(c\)](#)].

The apparent density of the powder compact depends on the displacement speed of the punch and the rate of increase of the force, respectively. Therefore, the displacement speed of the punch or the rate of increase of the force shall be recorded in the test report.

NOTE Taking into account the different press technologies (mode 1 and mode 2), it is difficult to specify a rate of increase of the force as well as the displacement speed of the punch. At least one of these parameters is to be mentioned on the test report.

7.5.6 Perform decompression slowly (for example, 10 mm/min) to avoid breaking the powder compact.

7.5.7 Pull out the upper punch from the die.

7.5.8 Eject the powder compact by using a relative movement between the die and the lower punch [see [Figure 2\(d\)](#)]. Weigh the mass of the powder compact to the nearest 0,001 g, and measure the dimensions of the powder compact to the nearest 0,01 mm in a time range between about 10 s to 100 s after ejection.

NOTE Spring-back is an important component of compaction behaviour. This value can be calculated using the inside diameter of the die and the measured outside diameter of the powder compact.

7.6 Compaction pressures

For plotting the compaction curve of the powder at different pressures, the pressures applied could include 25 MPa, 50 MPa, 100 MPa, and 200 MPa. If compaction properties are to be determined at a single pressure only, this pressure should be one of the pressures given above.

8 Expression of results

8.1 Calculation

The apparent density of the powder compact is given by Formula (1):

$$\rho_a = m / V \quad (1)$$

Calculate the apparent density in g/cm³ to the nearest 0,01 g/cm³.

Express the compaction properties for a given compacting pressure as the average of the three apparent densities, obtained at the specified pressure.

8.2 Compaction curve

Draw the compaction curve of the powder through points representing the average of determinants of ρ_a at each of the specified pressures (the variation in apparent density of powder compacts as a function of compressive pressure), as shown in [Figure 3](#).

9 Test report

The test report shall be in accordance with the reporting provisions of ISO/IEC 17025 and shall contain the following information if available:

- a) the name of the testing establishment;
- b) the date of the test, report identification and number, operator, and signatory;
- c) the temperature and relative humidity in laboratory;
- d) a reference to this International Standard (i.e. ISO 17172);
- e) all details for identification of the ceramic powder (material type, manufacturer, batch or code number);
- f) the pre-treatment condition of granulated or ungranulated ceramic powder;
- g) the type, nature, and amount of lubricant and any other organic additives used in the test, including:
 - 1) lubrication of the die walls, or no lubrication;
 - 2) lubrication of the powder, or no lubrication (state how the lubrication has been added);
 - 3) other organic additives;
- h) all details for identification of the press (type, model) and the die (inside diameter, material);
- i) the pressing mode (mode 1 or mode 2);
- j) the compacting pressures;
- k) the displacement speed of the punch (or the rate of increase of the force);
- l) the dimensions, mass, and apparent density of the powder compacts;

- m) the result obtained including the compaction curve;
- n) the details of any occurrence which could have affected the result;
- o) the comments about the test or test results.

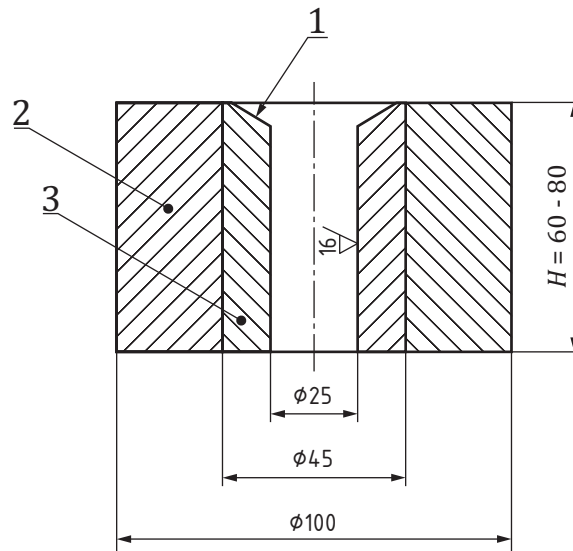

(a) Die

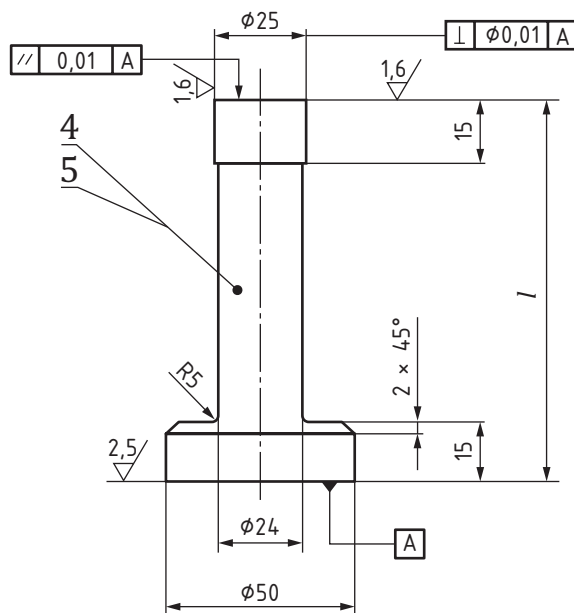

(b) Upper and lower punch

Key

- 1 ejection cone (height: 5 mm; increase of diameter: app. 1 %)
- 2 shrink ring
- 3 hard material
- 4 upper punch, $l = H - 10$
- 5 lower punch, $l = H + 35$

Figure 1 — Example of cylindrical die and punches

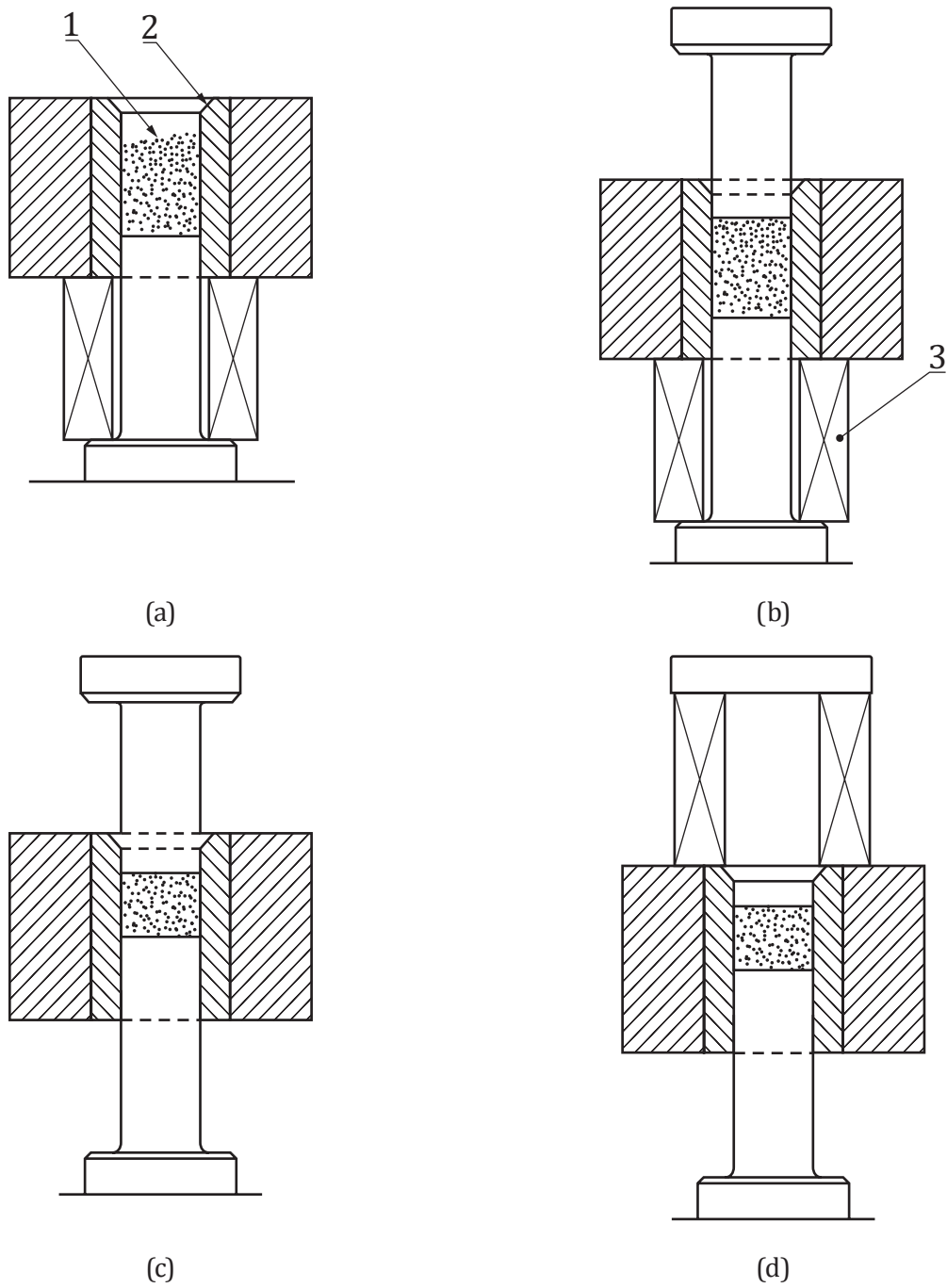

Key

- 1 powder
- 2 ejection cone
- 3 spacer

Figure 2 — Diagram of compaction and ejection

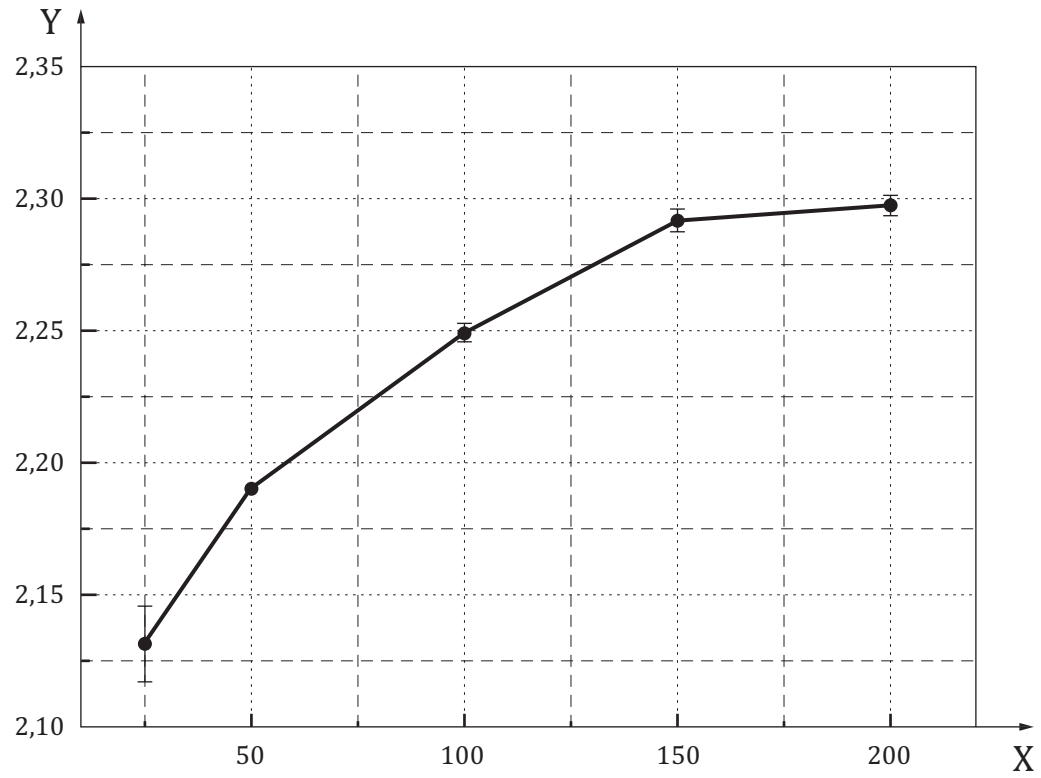
**Key**

X pressure (MPa)

Y apparent density (g/cm³)**Figure 3 — Example of compaction curve of alumina powder**

Bibliography

- [1] EN 725-10:2007, *Advanced technical ceramics — Methods of test for ceramic powders — Part 10: Determination of compaction properties*
- [2] KS L 1625:2012, *Testing method for compaction property of fine ceramic powders*

