

INTERNATIONAL STANDARD

ISO 17121

First edition
2000-10-15

Cinematography — Work stations used for film and video production — Requirements for visual and audio conditions

*Cinématographie — Stations de travail utilisées en production de film et
vidéo — Prescriptions pour les conditions visuelles et audio*



Reference number
ISO 17121:2000(E)

© ISO 2000

PDF disclaimer

This PDF file may contain embedded typefaces. In accordance with Adobe's licensing policy, this file may be printed or viewed but shall not be edited unless the typefaces which are embedded are licensed to and installed on the computer performing the editing. In downloading this file, parties accept therein the responsibility of not infringing Adobe's licensing policy. The ISO Central Secretariat accepts no liability in this area.

Adobe is a trademark of Adobe Systems Incorporated.

Details of the software products used to create this PDF file can be found in the General Info relative to the file; the PDF-creation parameters were optimized for printing. Every care has been taken to ensure that the file is suitable for use by ISO member bodies. In the unlikely event that a problem relating to it is found, please inform the Central Secretariat at the address given below.

© ISO 2000

All rights reserved. Unless otherwise specified, no part of this publication may be reproduced or utilized in any form or by any means, electronic or mechanical, including photocopying and microfilm, without permission in writing from either ISO at the address below or ISO's member body in the country of the requester.

ISO copyright office
Case postale 56 • CH-1211 Geneva 20
Tel. + 41 22 749 01 11
Fax + 41 22 749 09 47
E-mail copyright@iso.ch
Web www.iso.ch

Printed in Switzerland

Contents

Foreword.....	iv
1 Scope	1
2 Normative references	1
3 Terms and definitions	1
4 Requirements	4
4.1 Arrangements of picture monitors and data monitors at work stations.....	4
4.1.1 Viewing distances.....	4
4.1.2 Range of vision	5
4.1.3 Arrangement of picture monitors.....	8
4.1.4 Arrangement of data monitors	10
4.2 Spatial arrangement and design	10
4.2.1 Viewing geometry	10
4.3 Viewing conditions	13
4.3.1 General.....	13
4.3.2 Luminance of the television screen.....	13
4.3.3 Lighting of the viewing room.....	13
4.3.4 Script lighting and console lighting.....	14
4.3.5 Colour of room	14
4.3.6 Reflections.....	14
4.3.7 Screen environment	14
4.3.8 Vibration levels	14
4.4 Picture monitors	15
4.5 Acoustic conditions.....	15
4.5.1 General.....	15
4.5.2 Recommended maximum permitted sound pressure level of continuous background noise	15
4.5.3 Required airborne sound isolation between rooms.....	16
4.5.4 Architectural acoustics with regard to buildings	16
4.5.5 Room acoustics	18
4.5.6 Sound monitors	18
4.6 Acceptance.....	20
5 Marking	20

ISO 17121:2000(E)**Foreword**

ISO (the International Organization for Standardization) is a worldwide federation of national standards bodies (ISO member bodies). The work of preparing International Standards is normally carried out through ISO technical committees. Each member body interested in a subject for which a technical committee has been established has the right to be represented on that committee. International organizations, governmental and non-governmental, in liaison with ISO, also take part in the work. ISO collaborates closely with the International Electrotechnical Commission (IEC) on all matters of electrotechnical standardization.

International Standards are drafted in accordance with the rules given in the ISO/IEC Directives, Part 3.

Draft International Standards adopted by the technical committees are circulated to the member bodies for voting. Publication as an International Standard requires approval by at least 75 % of the member bodies casting a vote.

Attention is drawn to the possibility that some of the elements of this International Standard may be the subject of patent rights. ISO shall not be held responsible for identifying any or all such patent rights.

International Standard ISO 17121 was prepared by Technical Committee ISO/TC 36, *Cinematography*.

Cinematography — Work stations used for film and video production — Requirements for visual and audio conditions

1 Scope

This International Standard specifies the requirements for work stations used for electronic image and sound production in film and video facilities and broadcasting organizations. It provides assistance in achieving a consistent and critical evaluation of television and video programme material with a view to facilitating programme exchange in commonly used review conditions.

This International Standard is not applicable to work stations based on general purpose office computers or film production by traditional methods.

2 Normative references

The following normative documents contain provisions which, through reference in this text, constitute provisions of this International Standard. For dated references, subsequent amendments to, or revisions of, any of these publications do not apply. However, parties to agreements based on this International Standard are encouraged to investigate the possibility of applying the most recent editions of the normative documents indicated below. For undated references, the latest edition of the normative document referred to applies. Members of ISO and IEC maintain registers of currently valid International Standards.

CIE 15.2:1986, *Colorimetry*.

CIE S005:1998, *CIE standard illuminant for colorimetry*.

EBU Specifications Techn. 3213:1975, *EBU standard of chromaticity tolerances of studio monitors*.

EBU Specifications Techn. 3263:1991, *Specification of grade-1 colour picture monitors*.

EBU-Recommendation R 23:1987, *Procedure for the operational alignment of grade-1 colour picture monitors*.

ITU-Report 624-4/90:1990, *Recommendations and Reports of the CCIR — Characteristics of television systems*.

ITU-Recommendation 500, volume XI:1974, *Recommendations and Reports of CCIR — Method for the subjective assessment of quality of television pictures*.

3 Terms and definitions

For the purposes of this International Standard, the following terms and definitions apply.

3.1

eye point term

point in space where the eyes of the user of a particular item of technical equipment are positioned

NOTE 1 It is dependent on the body dimensions of the user and the posture he or she adopts.

ISO 17121:2000(E)

NOTE 2 The technical equipment referred to in this case is a picture monitor or a data monitor.

3.2**viewing angle**

angle between the line of sight and the surface normal of the object of vision

3.3**image resolution**

capacity of the screen to display dots or lines separately

3.4**height of picture**

electronic image measured vertically

3.5**picture monitor**

device for the reproduction and visual assessment of electronic images

3.6**binocular vision**

sight with both eyes

3.7**field of fixation**

sum total of the object points which can be fixed with the head at rest, moving only the eyes

3.8**data monitor**

device for displaying alphanumeric characters and graphic representations

3.9**electronic image**

television picture produced by the technical processing of film, video, text and graphics in accordance with ITU-Report 624-4/90

3.10**detect**

notice that one or more optical stimuli exist

3.11**recognize**

determine what is seen through congruence being established between the object of vision and its remembered meaning

3.12**space of recognition**

space delimited by all the eye points from which all the characters displayed on a surface can be recognized with certainty

NOTE 1 The extent of the space of recognition is dependent on the viewing distance, the viewing angle and the size of the characters being looked at.

NOTE 2 A data monitor is an example of the type of surface referred to in this definition.

3.13**fixation****look**

directing the eyes at a point

NOTE 1 A normal-sighted eye assumed, the adjustment takes place in such a way that an image of the fixed point is formed in the middle of the fovea.

NOTE 2 Fixation is the prerequisite for the recognition of objects of vision.

3.14

surface normal

perpendicular onto the surface of the display (here, the screen)

3.15

control desk

operating console or work table with work equipment, for example keys, controls or measuring equipment, for controlling and processing of picture and/or sound

3.16

monitor wall

several picture monitors arranged next to each other vertically and/or horizontally

3.17

monocular vision

sight with one eye

3.18

near point

point to which the eye is adjusted at the highest dioptric power of its optical system

3.19

viewing distance

distance between the eye and the object of vision

NOTE Unless indicated otherwise, the viewing distance is based on the centre of the screen.

3.20

line of sight

straight line between the centrally-imaged object point and its image point

NOTE This line goes approximately through the two nodal points of the eye.

3.21

field of vision

field of fixation and visual field

3.22

object of vision

object in external space, the image of which on the retina leads to a perception

NOTE Objects of vision are electronic images on picture monitors and characters on data monitors.

3.23

visual angle

angle whose vertex is at the eye and whose angle sides encompass the object of vision

See Figure 2.

NOTE Unless indicated otherwise, the visual angle is based on the height of the object of vision.

3.24

peak luminance

luminance adjusted on a monitor that corresponds to the white level of the picture signal

ISO 17121:2000(E)

3.25

sound monitors

device (loudspeaker) for reproducing sound signals

3.26

extended field of fixation

space delimited by sum total of all object points that can be fixed with the body at rest, only moving the head and eyes

4 Requirements

4.1 Arrangements of picture monitors and data monitors at work stations

4.1.1 Viewing distances

4.1.1.1 General

When specifying viewing distances, determine the nature of the task in hand; for example, distinguish between assessing television images on picture monitors and reading text on data monitors.

The specifications assume viewers to have normal sight, in particular for colour television. Defective vision shall be corrected by aids to vision such as spectacles.

4.1.1.2 Viewing distances for picture monitors

This International Standard is based on television images in accordance with ITU¹⁾ (previously CCIR)-Report 624-4/90.

The viewing distance for picture monitors is specified as a multiple of the visible height of the picture h_B (millimetres) (see ITU Recommendation 500, volume XI, 1974).

The viewing distance as shown in Table 1 may vary depending on the nature of the task.

Table 1 — Viewing distances

Viewing distance ^a	Task requirements
from $4 h_B$ to $6 \cdot h_B$	suitable for quality assessment and for reliably correcting details of pictures
from $6 h_B$ to $9 \cdot h_B$	suitable for assessing and checking whole pictures
from $9 h_B$ to $14 \cdot h_B$	suitable for rough assessments
from $14 h_B$ to $20 \cdot h_B$	unsuitable for assessment; however, the picture content is still clearly recognizable for checking purposes
^a For observing HDTV (high definition television) images, the distances given may be halved.	

1) International Telecommunication Union.

4.1.1.3 Viewing distances for data monitors

The viewing distance for data monitors shall be selected so that individual characters and symbols on the screen are recognized from the position of the eye point. This is assured when the height of the character without ascenders or descenders, for example capital letters, appears at a viewing distance of 500 mm from a visual angle of at least 20 angular minutes (see Figures 1 and 2).

Viewing distances of less than 200 mm shall be avoided because this is less than the position of the near point.

For a viewing distance of 500 mm, the character height shall be at least 2,9 mm.

For viewing distances of more than 500 mm, a visual angle of 20 angular minutes is indicated if the height of the character corresponds to the actual viewing distance, divided by 170.

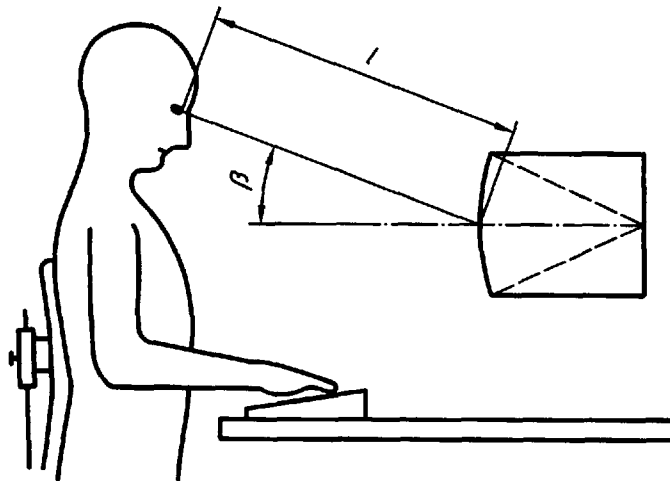

Figure 1 — Viewing distance l , and viewing angle β , displayed in the centre of the screen

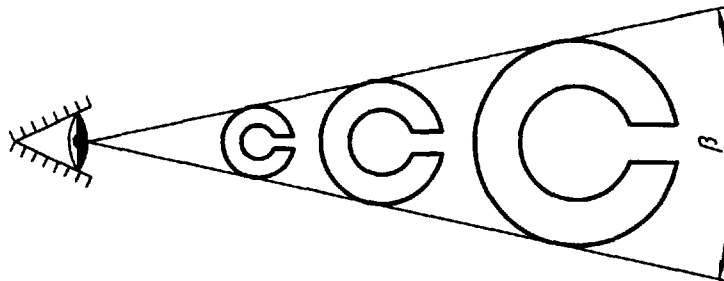

Figure 2 — Viewing angle β

4.1.2 Range of vision

4.1.2.1 General

The characteristics of the range of vision (lines of sight, fields of vision) and the sitting posture, based largely on the work station, are the key factors for the arrangement of picture monitors and data monitors.

The figures indicated (dimensions and angles) represent general ergonomic basic principles for the anthropometric design of work stations.

ISO 17121:2000(E)

4.1.2.2 Lines of sight

The course of the lines of sight forms the reference for the object of vision (for example television images, characters on data monitors, keys on the control desk) and, in conjunction with the fields of vision, is important for the arrangement of the work equipment.

In order to achieve optimum, that is large, visual angles, the lines of sight of the eye should correspond to the surface normal.

When the **lines of sight** are **horizontal**, the head is held up and the eyes are looking straight ahead; the line of sight is thus identical to the horizontal [see Figure 3a)].

With a **head-related line of sight**, the head is held in a relaxed position (the head axis inclined forward with respect to the trunk axis by 10° to 15°) and the eyes are looking straight ahead; the lines of sight are inclined by 10° to 15° with respect to the horizontal [see Figure 3b)].

With a **normal line of sight**, the eyes and head are in a relaxed position; the line of sight is inclined downwards by 25° to 35° with respect to the horizontal [see Figure 3c)].

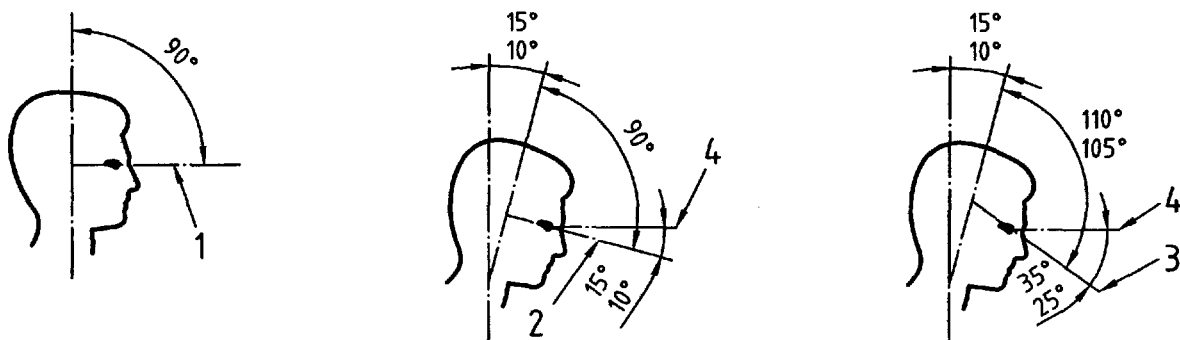

a) Horizontal line of sight

b) Head-related line of sight

c) Normal line of sight

Key

- 1 Horizontal line of sight
- 2 Head-related line of sight
- 3 Normal line of sight
- 4 Horizontal (0°)

Figure 3 — Angle of inclination of the lines of sight

4.1.2.3 Fields of vision

A distinction is made between monocular and binocular fields.

In the following cases, binocular fields are assumed:

- the fields of vision are distinguished according to optimum extent and maximum extent, whereby it is preferable to have the display in the optimum field;
- the fields have different vertical and horizontal extents.

All the visual stimuli that can be simultaneously detected, with the eyes and the head at rest, lie in the **visual field**.

In the visual field outside a field less than 1° around the fixation point, none of the objects looked at are recognized; all that is perceived are differences in luminance and colour.

The dimensions of the useful visual field depend on the characteristics of the visual stimulus (size, luminance, colour and temporal characteristics, for example blinking) and on the average luminance in the visual field.

Fatigue, psychic distraction and stress can reduce the visual field (see Figure 4).

The **visual field of fixation** is attained by enveloping all fixable points within the field of fixation by the visual field. It is thus the sum of all visual fields with the head at rest and moving (fixing) eyes (see Figure 5).

The **extended visual field** encompasses the area of all visual fields that come into being through movement of the head and eyes.

NOTE For definition of field of vision, see 3.21.

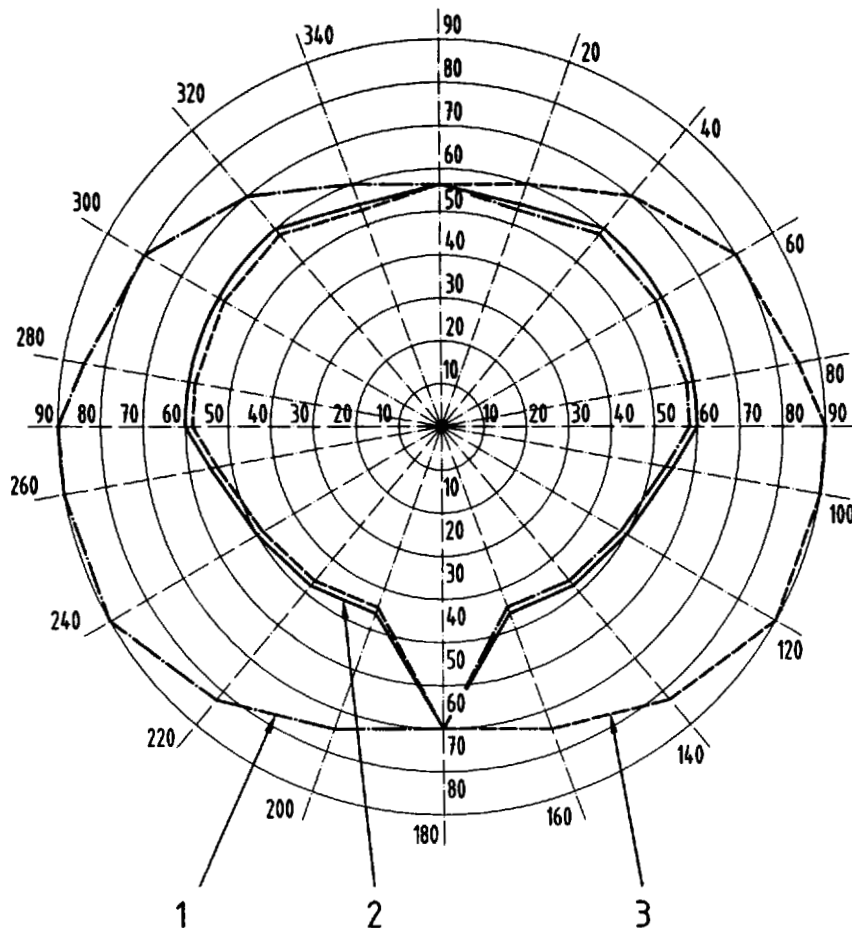

Key

- 1 Left eye
- 2 Binocular
- 3 Right eye

Figure 4 — Visual field for light stimuli

ISO 17121:2000(E)

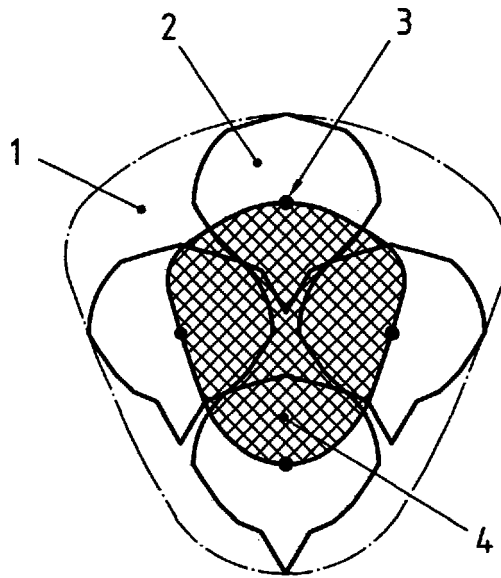
**Key**

- 1 Visual field of vision
- 2 Visual field
- 3 Objects at the limit of the field of fixation: centrepoint of the visual field
- 4 Field of fixation

Figure 5 — Visual field of fixation**4.1.3 Arrangement of picture monitors**

Set up the picture monitors taking into consideration the viewing distances in accordance with 4.1.1 and the fields of vision in accordance with 4.1.2.3. Arrange them so that there is no straining of the neck muscles while viewing, no strained body posture and no strain to the eyes.

The visual fields indicated in Figure 6 are based on the normal line of sight. If the visual task necessitates the head being held up, for example with a monitor wall, then the normal line of sight around the eye point shall be inclined upwards by 10° to 15°.

Arrange picture monitors that are viewed simultaneously in the optimum useful **visual field A**, in accordance with Figure 6. Arrange picture monitors for quality assessment of television images and for correcting image details in the angles given under **visual field A**.

Set up picture monitors that are frequently viewed from the operating board in the optimum useful **visual field of fixation B**, in accordance with Figure 6.

Picture monitors that only serve informative purposes and are only observed from time to time may be arranged in the **extended visual field C**, in accordance with Figure 6.

If they are arranged 15° above the horizontal line of sight, use office swivel armchairs with high backs that can be tilted far back. It is not permissible to direct the gaze more than 40° above the line of sight.

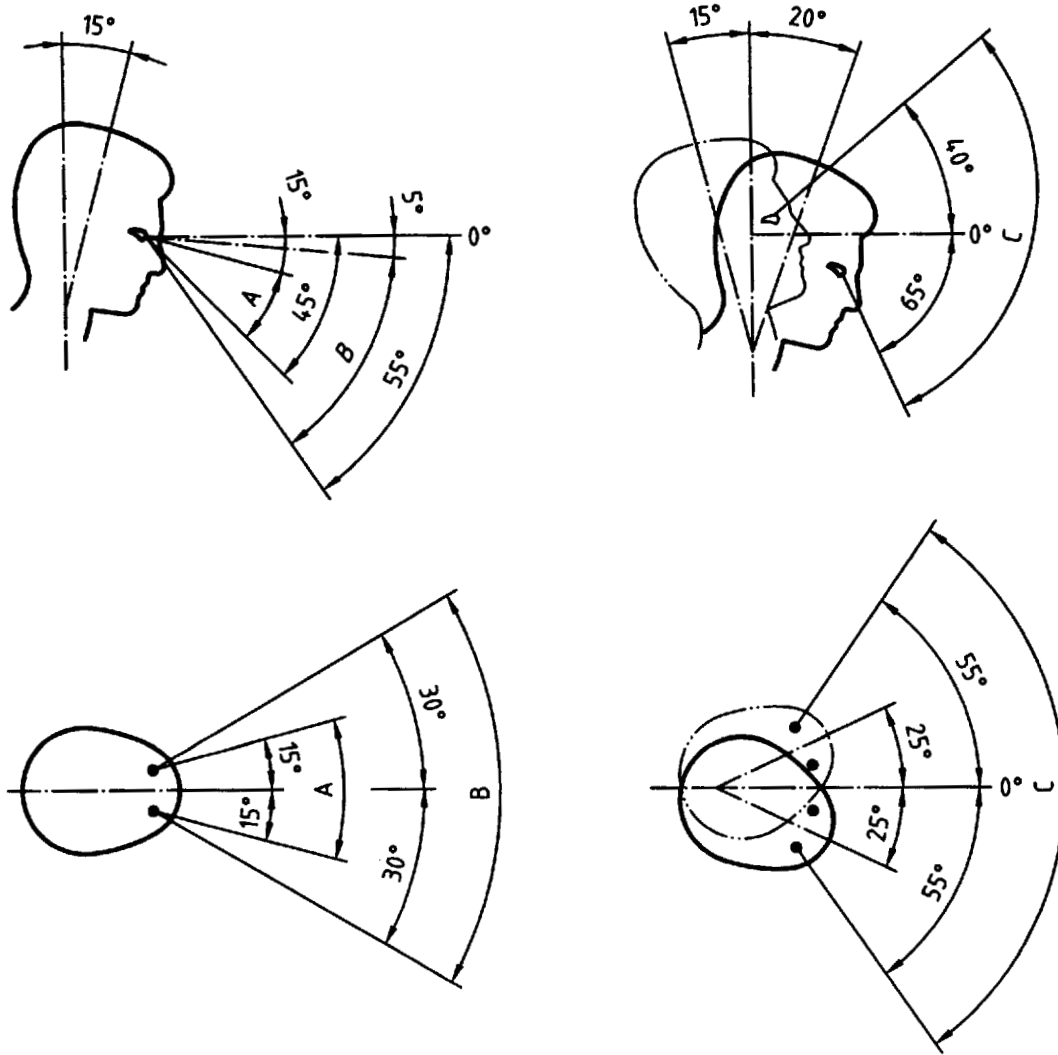

Key

- A Optimum useful visual field
- B Optimum useful visual field of fixation
- C Optimum useful extended visual field

Figure 6 — Optimum useful fields of vision

For optimum viewing, direct the line of sight vertically onto the centre of the screen. When the gaze is slanted, parallax errors and distortion result.

For a very critical image assessment, the viewer should look at the screen at an angle of $(0 \pm 5)^\circ$ horizontally as well as vertically to the surface normals.

When viewing several screens, limiting deviations are permissible.

The following limiting deviations for horizontal viewing angles for quality assessment shall not be exceeded:

Quality assessment:	high	moderate	low
Limiting deviations:	$\pm 15^\circ$	$\pm 30^\circ$	$\pm 50^\circ$

If the limiting deviations cannot be adhered to, the screens shall be turned into the line of sight.

ISO 17121:2000(E)

In the vertical direction, the viewing angle shall not deviate more than $\pm 15^\circ$ from the surface normals; in order to avoid exceeding these limits, tilt the picture monitor accordingly.

4.1.4 Arrangement of data monitors

For data monitors in film and video studios and sound production facilities, recognition of all the characters reproduced on the screen in the space of recognition shall be targeted.

The space of recognition extends from the centre vertical to the display surface (see Figure 7). It is delimited by an envelope surface upon which are all the eye points from which the most distant character on the display surface shall be reliably recognized.

This is ensured by maintaining the minimum visual angle. On the side towards the screen, a surface that stretches parallel to the display surface at a distance from the near point delimits the space of recognition. Its extent is dependent on the height of the characters and the form of the screen surface.

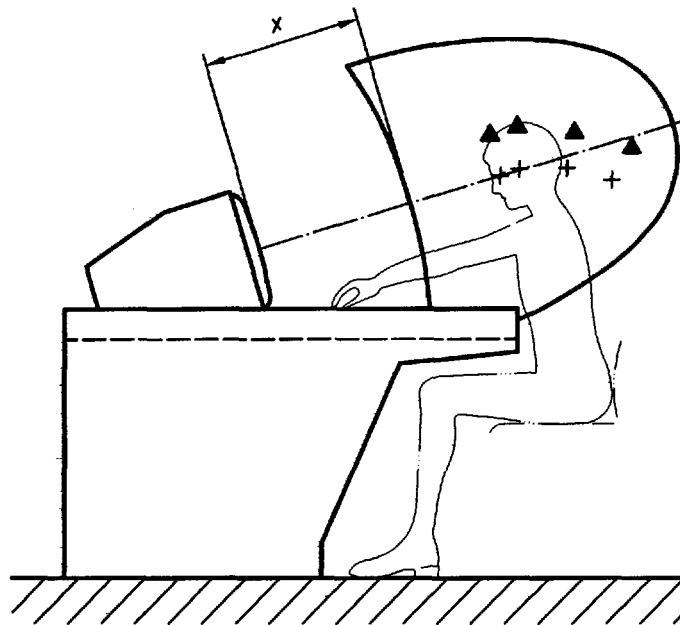

x = Near point 50 cm

+ 5th percentile

▲ 95th percentile

Figure 7 — Vertical section through space of recognition of a screen with the eye points of the 5th and 95th percentiles of those employed, with sitting posture

4.2 Spatial arrangement and design

4.2.1 Viewing geometry

4.2.1.1 General

In designing the layout of monitor walls and control desks, the lowest level of a monitor arrangement at the back of a control desk is dependent on the viewing geometry and it is determined by the eye reference point, the viewing distance and the height of the top edge of the control desk.

4.2.1.2 Eye reference point

The location of the eye reference point is dependent on the sitting posture and body size of the person sitting at the control desk. Assuming the upright sitting posture and using the body template for women in the fifth percentile, a height of about 1180 mm above the floor will result .

With the head in a relaxed position (head axis angled about 15° forward in relation to the torso axis), the eye point lies on a vertical reference line that approximately touches the front edge of the control desk (see Figure 8).

If a sitting posture leaning back is adopted, the eye point shifts approximately to a circular arc behind the vertical reference line.

The centre of the circle is the hip joint in an upright sitting posture.

When viewing images that are arranged 15° above the horizontal line of sight, a sitting posture leaning back should be adopted.

With the aid of a body template, and with the head in a relaxed position, adopting a hip joint angle equal to 105°, an eye reference point results that lies behind the vertical reference line, at almost the same height above the floor, dependent on body size, at 120 mm to 200 mm.

4.2.1.3 Lower level of picture monitor

With the aid of the eye reference point, the specified moderate viewing distance, the height of the upper edge of the control desk and its horizontal distance to the vertical reference line, the height of the lower level of the picture monitor, if necessary taking in a monitor caption, shall be determined by the sight limiting line in accordance with Figure 8. The minimum depth of the maintenance space shall be taken into consideration.

The height of the lower level of the picture monitor can be geometrically determined in accordance with Figure 8 or calculated with equation (4).

Before calculating, determine the viewing distance d desired by the user as a multiple of the image height h_B , in accordance with 4.1.1.2.

$$d = n \cdot h_B \tag{1}$$

For monitor walls, the centre viewing distance d_m is the horizontal distance of the eye reference point to the vertical of the front of the monitor. It is specified:

$$d = d_m \tag{2}$$

$$\tan \alpha = (h_{AP} - h_{OK})/t_{OK} \tag{3}$$

$$h_U = h_{AP} - d_m \cdot \tan \alpha \tag{4}$$

where, in equations (1) to (4) and in Figure 8,

- n is the chosen multiple of the picture height;
- h_U is the height of the lower level of the picture monitor above the floor;
- h_{OK} is the height of the upper edge of the control desk above the floor;
- h_{AP} is the height of the eye reference point above the floor;
- h_B is the picture height of the picture monitor;
- t_{OK} is the horizontal distance between the upper edge of the control desk and the eye reference point;

ISO 17121:2000(E)

- t_{MW} is the horizontal distance between the upper edge of the control desk and the monitor wall;
- t_W is the horizontal distance between the control desk and the monitor wall (maintenance space);
- d is the viewing distance between the eye reference point and the centre of the picture monitor;
- d_m is the moderate viewing distance;
- γ_{MW} is the inclination of the upper monitor level to the vertical (max. 15°);
- γ_{KA} is the inclination of the control desk set-up to the vertical;
- α is the inclination of the sight-limiting line to the horizontal.

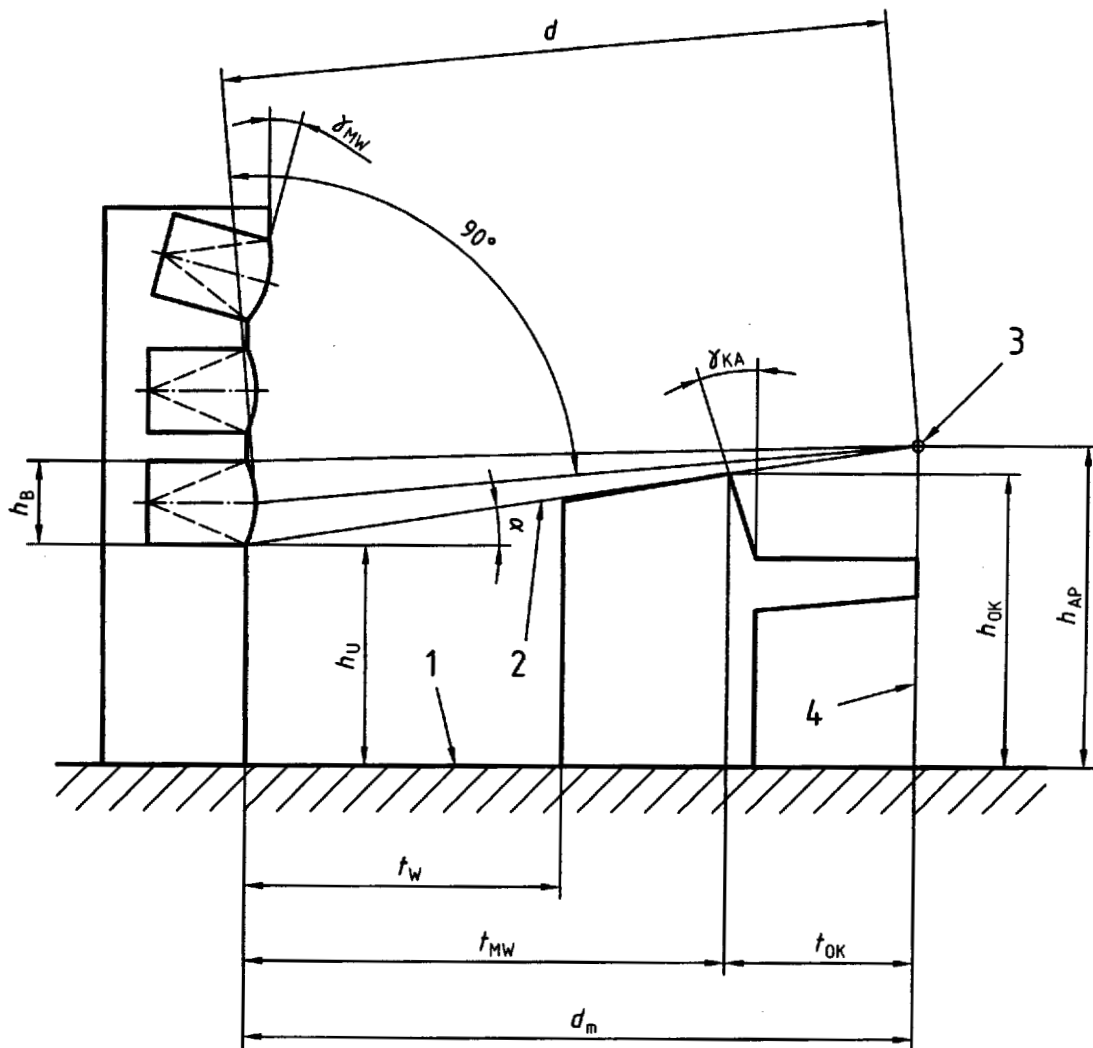

Key

- 1 Floor level
- 2 Sight-limiting line
- 3 Eye point
- 4 Vertical reference line

Figure 8 — Arrangement of monitor wall and control desk

4.2.1.4 Design of monitor walls

Monitor walls shall be designed and set up so that all viewing distances and viewing angles for the principal users lie within the limiting deviations specified in 4.1.3.

4.3 Viewing conditions

4.3.1 General

The viewing of television images in production studios requires viewing conditions appropriate for different tasks. For some tasks, viewing images has only an orienting function and is therefore principally an image viewing situation which is not fatiguing, even over extended periods of time. Nevertheless, the uniformity and comparability of the television picture image shall be given priority at quality assessment work stations, where qualitative image assessment is carried out (for example image control, acceptance inspection) and/or where, as a result of negative assessment, changes have to be made (for example frame transmission control, colour correction, design of the take or shot).

4.3.2 Luminance of the television screen

The peak luminance of the television screens shall not exceed 150 cd/m^2 in order to ensure high resolution and to avoid bothersome flickering, particularly with larger monitor walls (sensitivity to flickering is greater with peripheral sight). This value is based on the picture monitors commonly used at present with cathode ray tubes at 50-Hz frequency. (A value of 120 cd/m^2 is commonly used at present with cathode ray tubes at 60-Hz frequency.)

NOTE Higher frequencies suitable for image production and quality assessment are not attainable at present.

For quality assessment work stations, the peak luminance of the television screen shall be adjusted to $(80 \pm 5) \text{ cd/m}^2$.

4.3.3 Lighting of the viewing room

The lighting in the viewing room shall be adjusted to the television picture image.

The maximum lighting results from the requirement that, for an image contrast appropriate to a studio, the visible vertical illumination on the screen of the switched-off monitor shall not exceed 0,5 % of the peak luminance of the image.

At quality assessment work stations with the specified peak luminance of 80 cd/m^2 , the vertical illumination shall thus be smaller than 0,4 lux.

In order to fulfil this condition with adequate room lighting, the monitor screens should have dark backgrounds (diffuse reflection factor $\beta_{45^\circ, 0^\circ} < 20 \%$).

The colour of the light in the viewing room should be, as far as possible, in compliance with the CIE standard illuminant D65 for achromatic television (colour coordinates: $x = 0,3127$, $y = 0,3290$, correlated colour temperature: 6500 K). At quality assessment work stations, the limiting deviations of the colour (displayed in $u-v$ -colour coordinate diagram²⁾ lie within a circle around D65 with $r = 0,003$; expressed as correlated colour temperature, this corresponds approximately to limiting deviations of $\pm 500 \text{ K}$.

At quality assessment work stations in particular, the illuminant chromaticity shall not change if the light becomes dimmer.

2) In accordance with CIE UCS 1960 colour diagram: television reference white (EBU Specifications Tech. 3213) $u = 0,1978$, $v = 0,3122$. CIE UCS 1960 is no longer used; it has been replaced by CIE 1976 UCS diagram and is described in CIE 15.2.

ISO 17121:2000(E)**4.3.4 Script lighting and console lighting**

In general, the intensity of script and console lighting should not exceed 200 lx or be less than 100 lx.

At quality assessment work stations, script lighting shall not exceed 100 lx and console lighting shall not exceed 40 lx.

The conformity of the illuminance chromaticity to the CIE standard illuminant D65 specified for achromatic television shall be noted.

4.3.5 Colour of room

At quality assessment work stations, the viewing room in the viewer's field of fixation shall be neutral matt (achromatic) white to light grey. In the rest of the room, colours are permissible if they do not influence the colour neutrality in the viewer's field of fixation.

NOTE A slight deviation from achromatic of the colour of the room in the field of fixation can be compensated by lighting in a contrasting colour.

4.3.6 Reflections

Avoid furniture, fixtures or fittings with reflecting surfaces in the viewer's field of fixation as far as possible. This shall be achieved by selecting non-reflective, matt surfaces as well as inclining surfaces and appropriate arrangement of the lighting. At quality assessment work stations, the luminance from reflecting surfaces, measured from the eye position of the viewer, shall not exceed 10 % of the peak luminance of the television picture, that is no more than 8 cd/m².

Reflections on the screen shall be avoided.

4.3.7 Screen environment

The immediate environment of the screen (screen form) shall not appear as a dark frame but, rather, as a light, neutral grey (diffuse reflection factor $\beta_{45^\circ, 0^\circ}$ approximately 30 % to 50 %).

If the screen form renders the front glass of the cathode ray tube lighter or reflects in the front glass, the darker colour is preferred.

In order to avoid glare, the rest of the environment shall not be too light or too dark.

At quality assessment work stations with particularly strict requirements (for example correction of colours, acceptance inspection), in order to adapt the eyes, the screen to be viewed should be surrounded by a field at approximately 10 % of the peak luminance of the television screen in order to correspond to the specified peak luminance of 80 cd/m² for a surrounding field with $(8 \pm 2,5)$ cd/m². The area of the surrounding field should be at least eight times the area of the television picture image.

The colour of the surrounding field should be in conformity with the CIE standard illuminant D65 specified for achromatic television.

If the surrounding field serves as a reference in critical work, the limiting deviations of the colour, shown in the $u-v$ colour-coordinate diagram, shall lie within a circle around D65 with $r = 0,002$; expressed as most similar colour temperature, this corresponds approximately to limiting deviations of ± 300 K.

4.3.8 Vibration levels

Rooms shall be free from vibrations from heating/cooling/electrical/mechanical operating systems and heavy transportation systems, that is trucks, trains, aircraft.

4.4 Picture monitors

In relation to the work station, the picture monitors within the scope of this International Standard should be in conformity with the EBU-Specifications Techn. 3263.

For quality assessment work stations, further guidance is given in the EBU Recommendations R23.

4.5 Acoustic conditions

4.5.1 General

In order to assess and process sound events, the control conditions in a room suitable for this purpose shall fulfil certain acoustic criteria. The control conditions are determined principally by the disturbing background noise in existence, the acoustic influence of the room on the signal to be processed and the characteristics of the sound monitor.

4.5.2 Recommended maximum permitted sound pressure level of continuous background noise

A distinction shall be made between the sound pressure level permanently in existence in a room and the operating sound level caused by the production.

Background noises are all those noises caused by the technical equipment in the building and in the studio when they are switched on. Background noise caused by air conditioners, together with device-related noise, are typical continuous background noises.

When considering the use of a room, the highest permissible sound level of continuous background noise shall be specified by the user. The highest permissible continuous background noise level for the third octave centre frequency from 50 Hz to 10 kHz as sound pressure level $L_{p, F_{eq}, T=30s}$ is indicated in the form of a table or limit curve (LC). Indicating single figure values is not sufficient. Continuous background noise shall not contain any tonal or periodic components. There is significant deviation between the limit curves depending on the use of the room. The highest limit curve assigned to a room group shall not be exceeded. The limit curves are derived from the internationally known "Noise Rating" (NR) curves (see Figure 9).

Radio station production studios:

Radio play		GK0
Classical music	chamber music	GK0
Classical music	symphony	GK5
Light music		GK15

Rooms in which predominantly speech is recorded: GK5 to GK10

Rooms in which predominantly sound quality is assessed and/or sound production takes place: GK5 to GK15

Television production studios and television and radio production rooms: GK10 to GK20

Production rooms with an office-like character: GK20 to GK25

Technical rooms: NR30 to NR35

where

- GK0 corresponds to 500 Hz NR0 inclusively; above 500 Hz, the value is constant 0 dB
- GK5 corresponds to 630 Hz NR5 inclusively; above 630 Hz, the value is constant 3,5 dB
- GK10 corresponds to 630 Hz NR10 inclusively; above 630 Hz, the value is constant 7,5 dB

ISO 17121:2000(E)

- GK15 corresponds to 1 kHz NR15 inclusively; above 1 kHz, the value is constant 10 dB
- GK20 corresponds to 4 kHz NR20 inclusively; above 4 kHz, the value is constant 10 dB
- GK25 corresponds to NR25

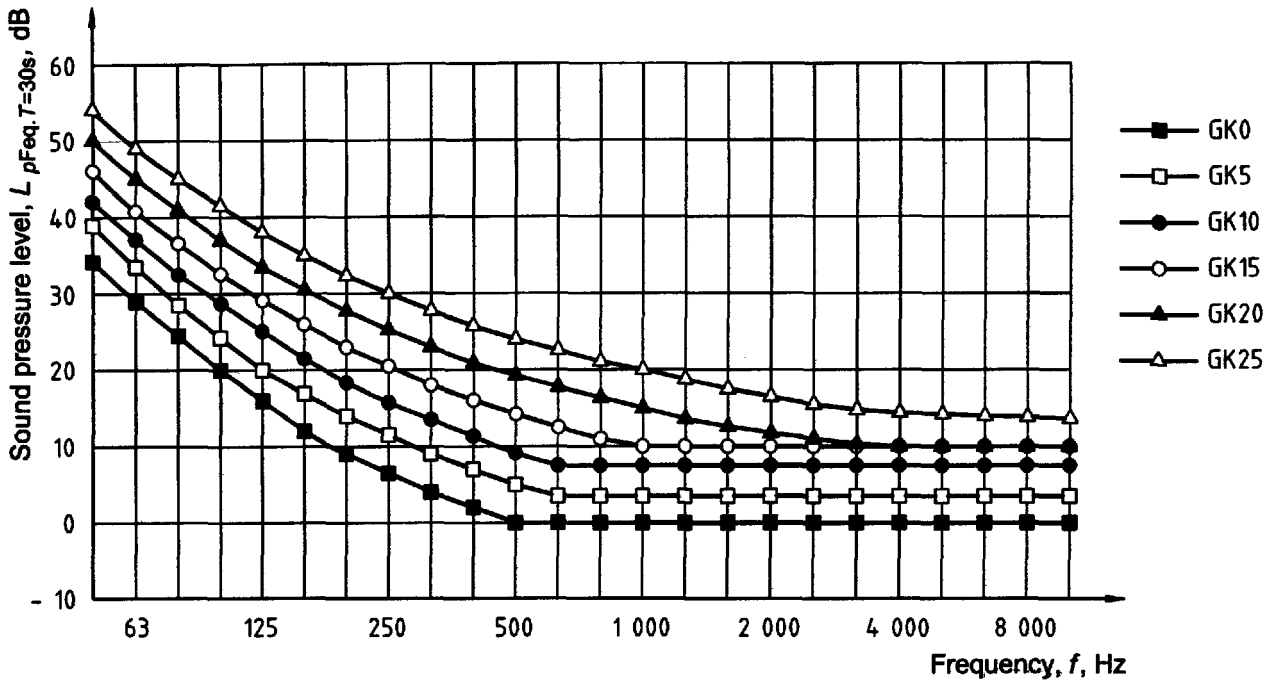

Figure 9 — Limit curves for the maximum permitted continuous background noise level (third octave sound pressure level)

4.5.3 Required airborne sound isolation between rooms

The required sound isolation with regard to airborne sound between a studio and the adjoining rooms is determined by the difference between the operating sound level of the noisiest of the adjoining rooms and the highest permissible continuous background noise level for the studio.

The operating sound level is the percentile level L_1 of the level arising during production (see Figure 10).

4.5.4 Architectural acoustics with regard to buildings

The most important architectural acoustic measure is an appropriate ground-plan. Acoustically high-grade studios shall be situated as far away as is feasible from possible sources of disturbance.

Studio complexes should be separated by corridors or rooms.

With regard to partitioning elements, the structure-borne sound (in buildings), impact-borne sound and/or mechanical vibration always present in a building is radiated in the form of airborne sound, even if there is the required sound isolation regarding airborne sound between a studio and the adjoining rooms, in accordance with 4.5.3.

In order to achieve adequate decoupling of structure-borne sound, impact-borne sound and/or mechanical vibration, all studios should be constructed in accordance with the "room within a room" principle.

When planning and installing domestic technical equipment, care shall be taken to limit the discharge of structure-borne sound, impact-borne sound and/or mechanical vibration into the building while the plant is in operation.

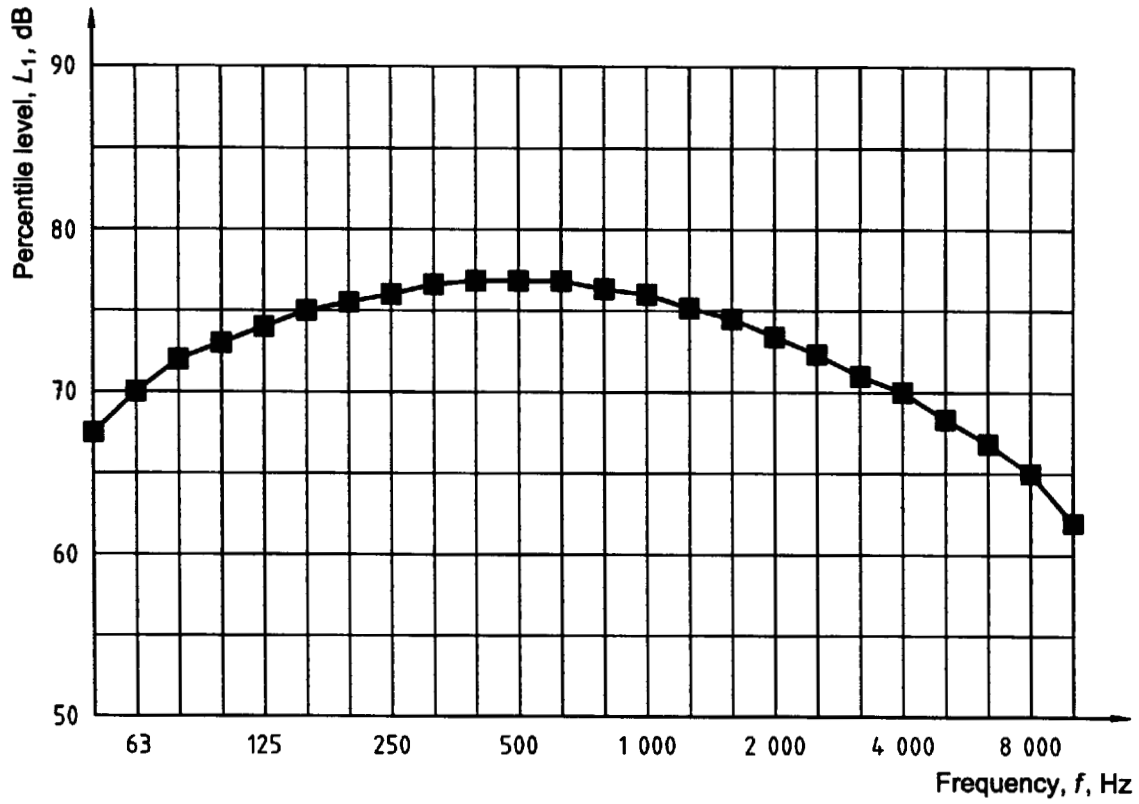

Figure 10 — Operating sound level in studio complexes not used for music production

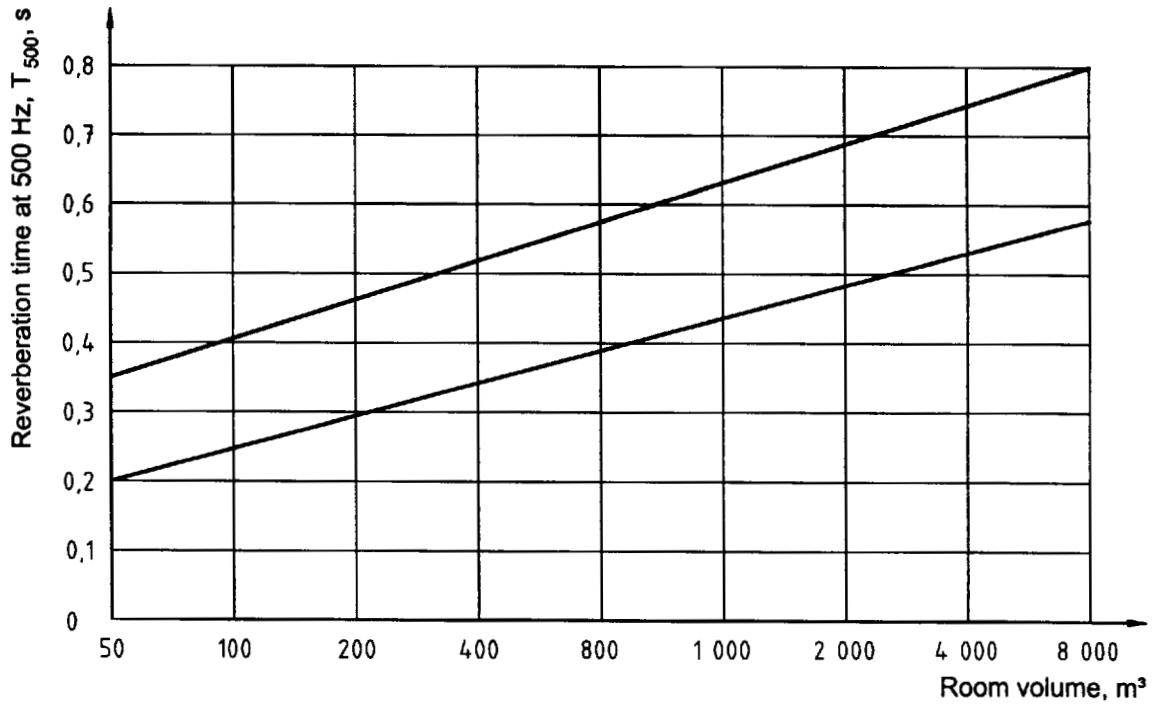

Figure 11 — Reverberation time as a function of room volume

ISO 17121:2000(E)

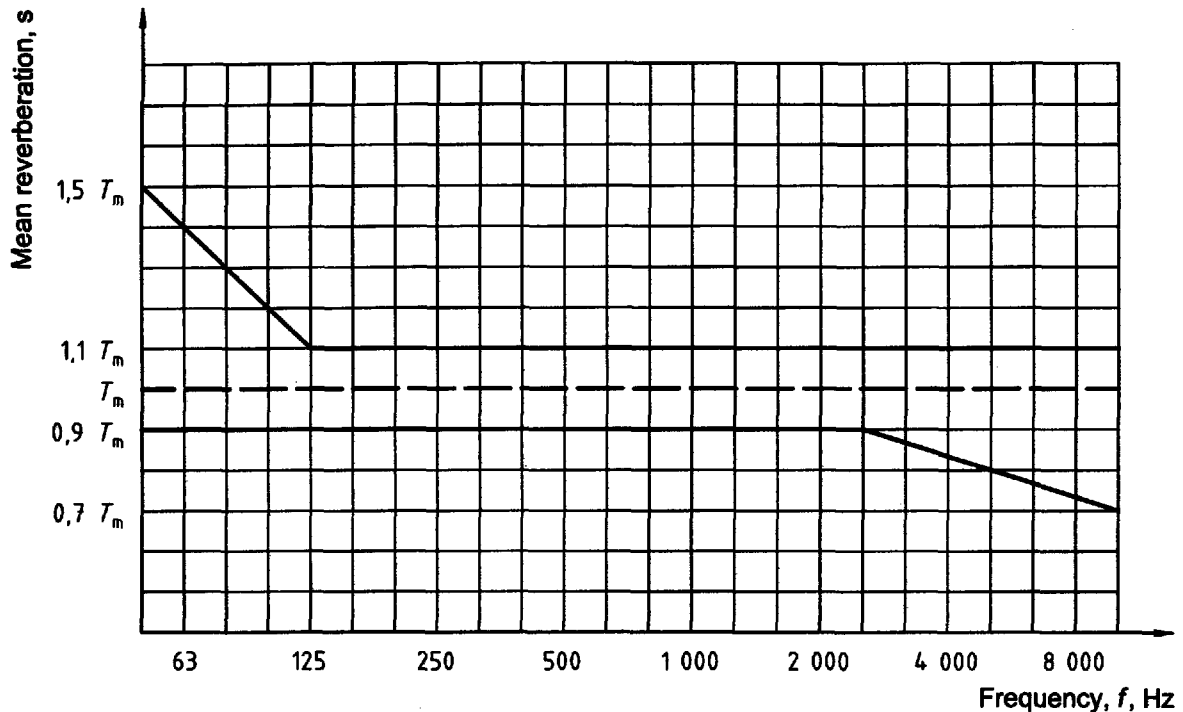

Figure 12 — Tolerance field for reverberation time

4.5.5 Room acoustics

4.5.5.1 General criteria

Net volumes smaller than 40 m³ should be avoided.

The rooms should be symmetric, based on the control axis and/or speaker microphone axis. Cube-shaped rooms, concave surfaces, niches and pillars, etc. should be avoided. In addition, length, width and height should not be in integral proportion to each other.

4.5.5.2 Reverberation time

The reverberation time is dependent on the technical production requirements and the volume of the room.

Standard values are given in Figure 11, in which the reverberation time T at 500 Hz is shown as a function of volume, with upper and lower limits.

When selecting the reverberation time, it shall also be noted that the shorter the reverberation time, the greater the effect of unavoidable reflecting surfaces. In such cases, longer reverberation times are preferable.

The tolerance field for the reverberation time in accordance with Figure 12 applies to studios with strict acoustic requirements.

In addition, the difference between the measured reverberation times T in successive third octave bands shall not exceed the limiting deviation $\pm 0,1 T_m$, at least in the frequency range between 200 Hz and 10 kHz, where T_m is the arithmetic mean value of the measured reverberation time T in the third octave bands 200 Hz to 2,5 kHz.

4.5.6 Sound monitors

Sound monitors should be free-standing and set up symmetrically in front of the space-partioning surfaces. The sound monitors should be moveable so as they can be put in the best position in relation to the transmission factor between sound monitor and control position (see Figures 13 and 14).

If installation in a stand, frame, rack or wall is necessary, care should be taken that the front of the sound monitor is flush with the front of the frame or wall. The sound monitor shall not cause the stand, frame or wall to vibrate audibly.

The principal beam axis of the sound monitor should be at ear level (1,2 m to 1,3 m) so that the whole front is visible from the control point.

The distance between the sound monitor and the walls and ceilings, as well as the distance between the control position and the back room partition surface, should be more than 1 m.

Stereo basis $b = 3 \text{ m to } 4,5 \text{ m}$

Hearing distance $l = (0,9 \pm 0,3) b \text{ in m}$

Basis angle $\delta = 60^\circ \pm 15^\circ$

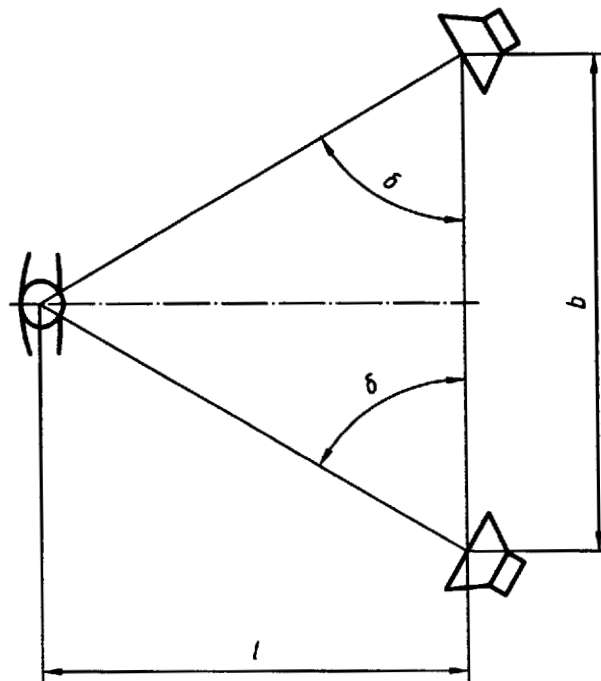

Figure 13 — Sound monitors, horizontal arrangement

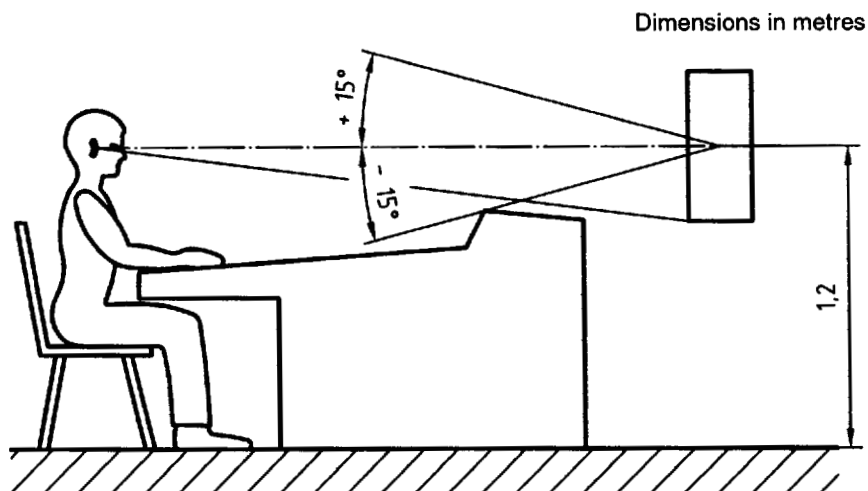

Figure 14 — Sound monitors, vertical arrangement

ISO 17121:2000(E)

4.6 Acceptance

Before equipment is put into operation, it shall be accepted by an authorized inspector.

This acceptance is limited to inspecting the

- actuating facilities
- energy supply
- parameters of lighting
- acoustic parameters, continuous background noise level and reverberation time.

The acceptance is carried out through inspection and measurement.

The results shall be listed in an inspection report which shall contain at minimum the following data:

- a) place and time of inspection and testing;
- b) name of authorized inspector;
- c) place where the documentation on the equipment and the manufacturer has been deposited;
- d) optional equipment;
- e) measuring results and comments;
- f) particularities.

5 Marking

Equipment shall be marked by the manufacturer in accordance with national legal regulations. Any required warning notices shall be affixed to the apparatus.

ISO 17121:2000(E)

ICS 97.200.10

Price based on 20 pages

© ISO 2000 – All rights reserved