**Fine ceramics (advanced ceramics,
advanced technical ceramics) — Test
method for interfacial bond strength
of ceramic materials at elevated
temperatures**

*Céramiques techniques — Méthode d'essai pour la résistance de
l'interface des matériaux céramiques à températures élevées*





COPYRIGHT PROTECTED DOCUMENT

© ISO 2013

All rights reserved. Unless otherwise specified, no part of this publication may be reproduced or utilized otherwise in any form or by any means, electronic or mechanical, including photocopying, or posting on the internet or an intranet, without prior written permission. Permission can be requested from either ISO at the address below or ISO's member body in the country of the requester.

ISO copyright office
Case postale 56 • CH-1211 Geneva 20
Tel. + 41 22 749 01 11
Fax + 41 22 749 09 47
E-mail copyright@iso.org
Web www.iso.org

Published in Switzerland

Contents

	Page
Foreword	iv
1 Scope	1
2 Normative references	1
3 Terms and definitions	1
4 Symbols and abbreviated terms	2
5 Principle	3
6 Apparatus	4
6.1 Test machine	4
6.2 Heating machine	4
6.3 Temperature measuring and indicating instruments	5
6.4 Data acquisition	5
6.5 Dimension-measuring device	5
6.6 Test fixture	6
7 Test pieces	7
7.1 Test piece size	7
7.2 Test piece preparation	8
8 Test procedure	8
8.1 Test mode and rate	8
8.2 Preparation of test pieces	9
8.3 Measurement of the cross-bonded area	9
8.4 Measurement of the tensile bond strength	9
8.5 Measurement of the shear bond strength	10
9 Calculation of results	11
9.1 Interfacial tensile bond strength	11
9.2 Interfacial shear bond strength	11
10 Test report	12
Bibliography	13

Foreword

ISO (the International Organization for Standardization) is a worldwide federation of national standards bodies (ISO member bodies). The work of preparing International Standards is normally carried out through ISO technical committees. Each member body interested in a subject for which a technical committee has been established has the right to be represented on that committee. International organizations, governmental and non-governmental, in liaison with ISO, also take part in the work. ISO collaborates closely with the International Electrotechnical Commission (IEC) on all matters of electrotechnical standardization.

The procedures used to develop this document and those intended for its further maintenance are described in the ISO/IEC Directives, Part 1. In particular the different approval criteria needed for the different types of ISO documents should be noted. This document was drafted in accordance with the editorial rules of the ISO/IEC Directives, Part 2. www.iso.org/directives

Attention is drawn to the possibility that some of the elements of this document may be the subject of patent rights. ISO shall not be held responsible for identifying any or all such patent rights. Details of any patent rights identified during the development of the document will be in the Introduction and/or on the ISO list of patent declarations received. www.iso.org/patents

Any trade name used in this document is information given for the convenience of users and does not constitute an endorsement.

ISO 17095 was prepared by Technical Committee ISO/TC 206, *Fine ceramics*.

Fine ceramics (advanced ceramics, advanced technical ceramics) — Test method for interfacial bond strength of ceramic materials at elevated temperatures

1 Scope

This International Standard specifies the method of test for determining the interfacial tensile and shear bond strength of ceramic-ceramic, ceramic-metal, and ceramic-glass joining at elevated temperature by the compression tests on the cross-bonded test pieces. Methods for test piece preparation, test modes and rates (load rate or displacement rate), data collection, and reporting procedures are addressed.

This International Standard applies primarily to the ceramic materials, including monolithic fine ceramics and whisker-, fibre- or particulate-reinforced ceramic composites. This test method can be used for materials research, quality control, and characterization and design data-generation purposes.

2 Normative references

The following documents, in whole or in part, are normatively referenced in this document and are indispensable to its application. For dated references, only the edition cited applies. For undated references, the latest edition of the referenced document (including any amendments) applies.

ISO 3611, *Geometrical product specifications (GPS) — Dimensional measuring equipment: Micrometers for external measurements — Design and metrological characteristics*

ISO 7500-1, *Metallic materials — Verification of static uniaxial testing machines — Part 1: Tension/compression testing machines — Verification and calibration of the force-measuring system*

IEC 60584-1, *Thermocouples — Part 1: Reference tables*

3 Terms and definitions

For the purposes of this document, the following terms and definitions apply.

3.1

advanced ceramic

advanced technical ceramic

fine ceramic

highly-engineered, high-performance predominately non-metallic, inorganic, ceramic material having specific functional attributes

3.2

cross-bonded sample

testing sample having the form of a symmetrical cross, which is prepared by joining two rectangle bars of the same shape and size

Note 1 to entry: See [Figure 1](#).

Note 2 to entry: The two bars joined to form the cross-bonded sample may be of the same or different materials.

Note 3 to entry: The approach used for joining may be any chemical or physical bonding.

Note 4 to entry: The two bars should be joined perpendicularly and symmetrically within $\pm 1^\circ$ ($\alpha = 90^\circ \pm 1^\circ$).

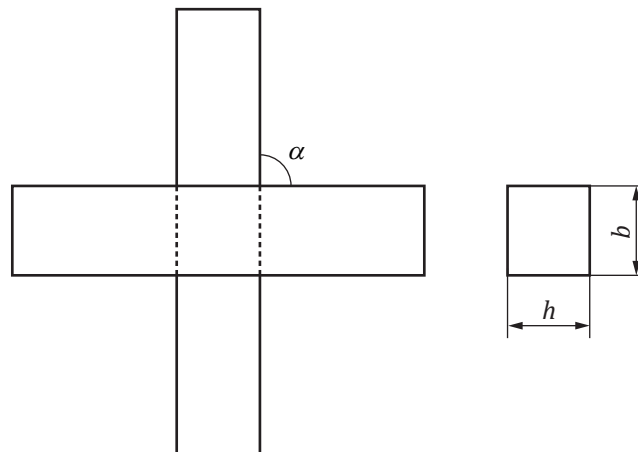

Figure 1 — Schematic diagram of cross-bonded samples

3.3 tensile failure load

maximum tensile load applied to the interface during a tensile bond strength test

3.4 tensile bond strength

maximum mean tensile stress applied to the interface during a bond strength test

Note 1 to entry: Tensile bond strength is calculated from the tensile failure load and the bonded area.

3.5 shear failure load

maximum shear load applied to the interface during a shear test of the cross-bonded sample

3.6 shear bond strength

maximum mean shear stress applied to the interface during a shear bond strength test

Note 1 to entry: Shear bond strength is calculated using the shear failure load and the shear-loaded area.

4 Symbols and abbreviated terms

For the purposes of this document, the symbols given in [Table 1](#) apply.

Table 1 — Symbols

Symbol	Designation	Unit	Reference
l	Test piece length	mm	Table 2
h	Test piece thickness	mm	Figure 1, Table 2
b	Test piece width	mm	Figure 1, Table 2
α	Vertical angle of cross-bonded sample	o	Figure 1
D	Diameter of the ball in pressure head	mm	Figure 3
σ_t	Tensile bond strength	MPa	Formula (1)
τ	Shear bond strength	MPa	Formula (4)
P_c	Critical load to debonding	N	Formulae (1), (4)
A_1	Tensile loaded area	mm ²	Formula (1)
A_2	Shear loaded area	mm ²	Formula (4)

Table 1 (continued)

Symbol	Designation	Unit	Reference
n	Number of valid tests	1	Formulae (2), (3), (5), (6)
$\bar{\sigma}_t$	Mean tensile bond strength	MPa	Formula (2)
$\bar{\tau}$	Mean shear bond strength	MPa	Formula (5)
s	Standard deviation	MPa	Formulae (3), (6)

5 Principle

A cross-bonded sample is loaded in compression which yields tensile or shear stress in the interface until the occurrence of the debonding in the interface at the test temperatures. Two different forms of mounting the cross-bonded sample in a fixture are designed to measure the interfacial tensile and shear bond strength, respectively. In the case of the former, a uniaxial tensile stress is generated when the test sample is subjected to compressive load, as shown in [Figure 2 a](#)). For the latter, a cross-bonded sample is loaded in compression to induce failure by shear at the interface, as shown in [Figure 2 b](#)). The test is usually performed at a constant crosshead displacement rate at high temperatures. The load at fracture and the bonded area are used to compute the tensile and shear bond strength.

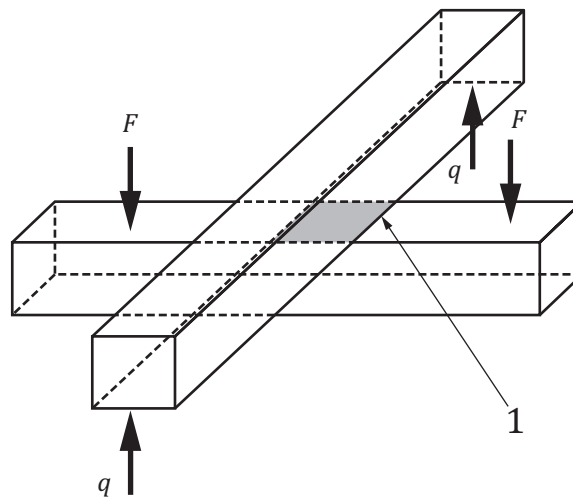

a) Schematic diagram of loading, supporting and bonded area for cross-bonded sample in the tensile bond strength test

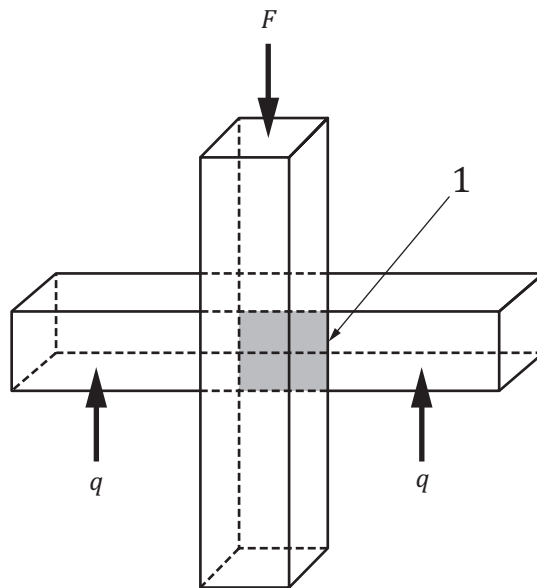

b) Schematic diagram of loading, supporting and bonded area for cross-bonded sample in the shear bond strength test

Key

- 1 bonded area
- F applied load
- q uniform resultant stress on the supporting surfaces

Figure 2 — Schematic diagram of measuring the tensile and shear bond strength using the cross-bonded test piece subjected to compressive load

6 Apparatus

6.1 Test machine

A suitable test machine capable of applying a uniform crosshead speed shall be used. The test machine shall be in accordance with ISO 7500-1, class 1, to an accuracy of 1 % of indicated load during compression or tension tests.

6.2 Heating machine

6.2.1 General

The furnace shall be capable of heating the test fixture and test piece as well as maintaining a uniform and constant temperature during the bonding strength test, by which an air, inert gas or vacuum environment should be available for test requirement. If an inert gas and vacuum chamber is used, and it is necessary to transmit the load through a seal, bellows or a fitting, it shall be verified that load losses or errors are less than 1 % of the expected fracture loads.

6.2.2 Test piece temperature stability

The furnace shall be controlled by a device for maintaining a constant temperature within ± 2 °C or better within the working space of the furnace, during the time that the test piece is loaded until it is fractured.

6.2.3 Test temperature uniformity

The furnace shall be capable of maintaining the test piece at uniform temperature. It shall previously be determined that the temperature of the test piece shall not vary by more than 10 °C after a 15-min hold time at the required test temperature.

6.2.4 Furnace heating rate

The furnace control device shall also be capable of controlling the heating rates of the furnace and preventing temperature overshoots.

6.2.5 Furnace stability

The time for the system to reach thermal equilibrium at the test temperature shall be determined for the test temperature to be used.

6.3 Temperature measuring and indicating instruments

6.3.1 General

The thermocouple temperature measuring equipment shall have a resolution at least 1 °C and an accuracy of 5 °C or better. Optical pyrometers, if used, shall have a resolution of at least 5 °C and an accuracy of 10 °C or better.

Note 1 Resolution is not intended to be confused with accuracy. Beware of instruments that have a resolution (readout) of 1 °C, but have an accuracy of only 10 °C; for example an instrument with a 1 % accuracy would only be accurate to ± 12 °C at 1 200 °C.

Note 2 Thermocouple temperature measuring instruments typically approximate the temperature-electromotive force (EMF) tables, but with a few degrees of error.

6.3.2 Thermocouples

Thermocouples in accordance with IEC 60584-1 shall be used. The thermocouple shall exhibit low thermal inertia (the diameter of the wires shall be not greater than 0,5 mm). The thermocouples shall have a sufficient length within the furnace (with respect to heat conduction along the wires). The measuring thermocouple tip shall be as close as possible to or contacting the test piece.

6.3.3 Verification of the thermocouple temperature measuring system

Thermocouples shall be checked periodically since calibration can drift with usage or contamination.

6.4 Data acquisition

Obtain at least an autographic record of the applied load versus crosshead displacement or testing time.

Use either analogue chart recorders or digital data acquisition systems. Recording devices shall be accurate to within 1 % of the selected range of the test equipment including readout unit and have a minimum data acquisition rate of 10 Hz with a response of 50 Hz deemed more than sufficient.

6.5 Dimension-measuring device

Micrometers and other devices used for measuring linear dimensions shall be accurate to at least 0,01 mm and shall be in accordance with ISO 3611. The micrometer shall not have a ball tip or sharp tip since these might damage the test piece. Alternative dimension measuring instruments may be used, provided they have a resolution of 0,01 mm or finer.

6.6 Test fixture

6.6.1 General

There are various types of fixtures for the compression of bond ceramic materials. The illustration (sketch) of the test fixtures is shown in [Figure 3](#). To avoid unsymmetrical stress in the sample, the top of the pressure head is machined into arc shape at two perpendicular directions, and should be in the middle line of the pressure head, as shown in [Figure 3 a](#)). Alternatively, a small ball is inlaid in the centre of the upper surface of the pressure head and the centre of the ball should be in the middle line of the pressure head, as shown in [Figure 3 b](#)). Thus, a point contact at the top centre of the pressure head can be realized in compressive process. The bearing shall be suitable and moveable span (the width of the groove) so that the cross-bonded sample can be inserted into the fixture freely and smooth contact, as shown in [Figure 3 c](#)).

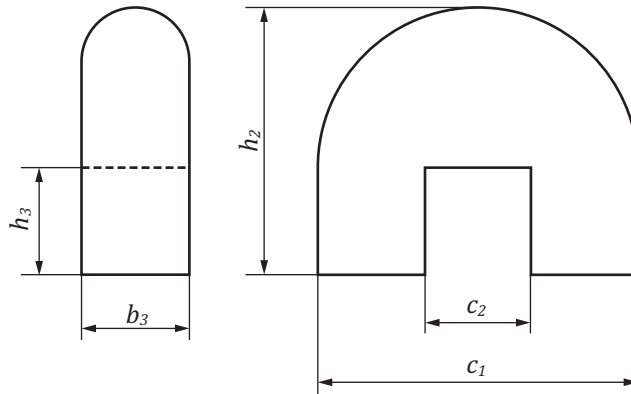

a) Pressure head used to apply load during tensile bonding strength tests

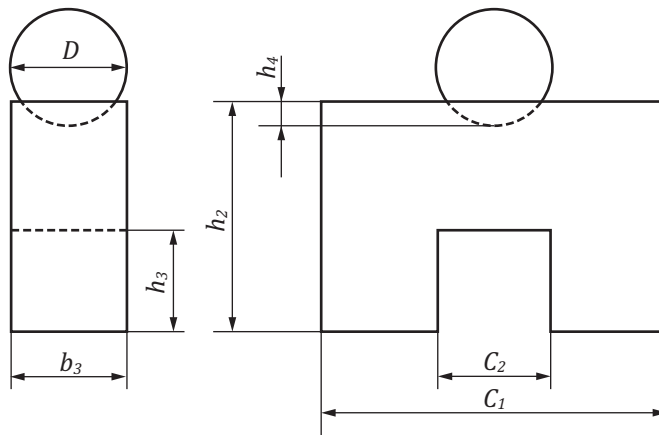

b) Alternative pressure head used to apply load during tensile bonding strength tests

Copyright International Organization for Standardization
 Provided by IHS under license with ISO
 No reproduction or networking permitted without license from IHS

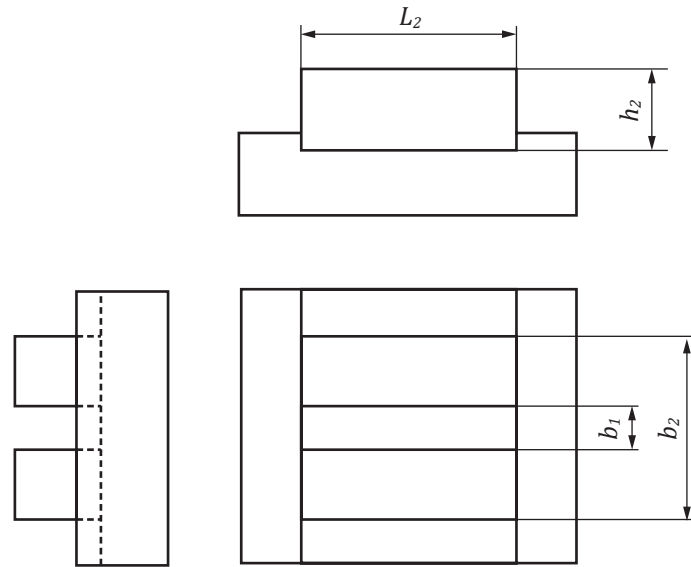

c) Bearing device for both tensile and shear bond strength tests

Figure 3 — Schematic illustration of the test fixtures

The pressure head is designed for applying the tensile load in the interface during the tensile bonding strength tests, which is unnecessary for measuring the shear bond strength. The mass of the pressure head should be added into the final load for calculating the strength.

To avoid the unsymmetrical tensile stress, it is recommended that the width of the pressure head be equal to that of test sample, e.g. $b = b_3$.

The parallelism tolerance on opposite longitudinal faces of the lower part of the fixture (bearing) shall not exceed 0,01 mm, and both the upper and lower surface should be smooth planes.

While the cross-bonded sample is put into the test fixture, as shown in [Figure 5](#) and [Figure 6](#), the inside bar would be smooth contact with two inner surfaces of the bearing, without friction when it moves.

The thickness of pressure head should be a little lower than the width of the groove, and the height is larger than the thickness of the bar, e.g. $b_3 < b_1$, $h_3 > h$.

6.6.2 Fixture material

The fixture material shall be as inert as possible for the test conditions used. The fixture shall be oxidation resistant if the testing is conducted in air. The fixture shall have negligible chemical reaction with and shall not contaminate at the test piece. The fixture shall remain elastic over the load and temperature ranges used. The bearing may be made of a ceramic with an elastic modulus of between 200 GPa and 500 GPa and a flexural strength greater than 250 MPa at elevated temperature. Silicon carbides are suitable as the fixture materials. Hot-pressed or sintered silicon carbides with low additive content are elastic up to temperature in excess of 1 500 °C. Siliconized silicon carbides and high purity alumina are less expensive, but can exhibit creep deformation at temperatures over 1 200 °C.

7 Test pieces

7.1 Test piece size

A rectangular test bar with a square section shall be prepared before bonding, as shown in [Figure 4](#). The vertical angle tolerance of adjacent faces should be within 1°. [Table 2](#) shows the recommended dimensions of the bars with the section size of $4 \times 4 \text{ mm}^2$, and the length should be larger than 12 mm. The parallelism tolerance on opposite longitudinal face is 0,015 mm. All of the bar samples shall not be chamfered.

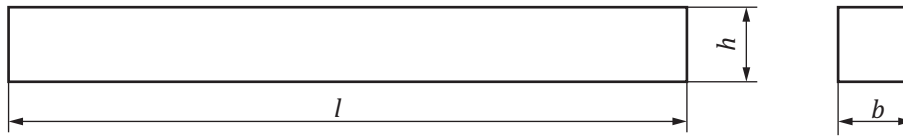

Figure 4 — Schematic illustrations of the rectangular test pieces

Table 2 — Recommended dimensions for cross-bonded sample and fixture

Dimensions in millimetres

Dimension	Description	Value	Tolerance
<i>l</i>	Length of the bar	>12	±0,5
<i>b</i>	Width of the bar	4	±0,1
<i>h</i>	Thickness of the bar	4	±0,1

NOTE Preferably, two rectangular bars with the same dimensions are joined for preparing the cross-sectional samples. The phase compositions of the two rectangular samples can be the same or different.

7.2 Test piece preparation

7.2.1 General

This International Standard allows several options for test piece preparation. Before the preparation, all surfaces of the bar are polished up to at least 1200# SiC paper, and then cleaned. Each pair of bars that need to bond (sometimes of the same material) is joined to form a symmetrical cross, as shown in Figure 1. The approach used for joining, depending on the aims of measurement, can be chemical or physical bonding.

NOTE The bonded surface is not polished compulsorily if the effect of the roughness of a true surface is considered.

7.2.2 Test piece storage

The test pieces shall be handled with care to avoid the introduction of damage after test piece preparation. Test pieces shall be stored separately and not allowed to impact or scratch each other.

7.2.3 Number of test pieces

A minimum of 6 test pieces shall be required for the purpose of estimating the mean interfacial tensile bond strength or interfacial shear bond strength.

A minimum of 30 test pieces shall be used if a statistical strength analysis (e.g. a Weibull analysis) is carried out. The use of 30 test pieces helps obtain good confidence limits for the bond strength distribution parameters including a Weibull modulus.

8 Test procedure

8.1 Test mode and rate

Use a universal mechanical test machine or other appropriate fixture with a crosshead speed of 0,5 mm/min for both tensile and shear bond strength tests.

The test rate should be sufficiently rapid so as to complete the test in the range of 10 s to 30 s, thereby obtaining the maximum possible tensile strength at fracture of the interface of the cross-bonded sample.

8.2 Preparation of test pieces

Bond two rectangular bars into a cross-bonded sample by chemical or physical ways.

Check the cross-bonded sample before the test; the two bars should be perpendicular to each other, and without any redundant at the rims of the bonded area.

For the cross-bonded sample in shear tests, the upper section of the vertical bar might be declined plane in which the peak is at the side of bond surface for avoiding possible bending stress.

8.3 Measurement of the cross-bonded area

Before the bond strength test, the cross-bonded area should be measured for calculations. Measure the length and width of the bonded area with accuracy of 0,02 mm or better.

8.4 Measurement of the tensile bond strength

To measure the tensile bond strength, place each test piece in the fixture using an arc-shaped pressure head or ball-shaped pressure head, as shown in [Figure 5](#). The cross-bonded sample should be inserted in the test fixture without any friction. The width of the pressure head shall be the same as that of the bar, and the pressure head should be parallel to the lower bar. The test pieces shall be heated to the set test temperature. Care shall be taken to ensure that the thermal expansion of the furnace does not cause the test piece preload to exceed 5 % of the expected average breaking force; it is preferable that the preload be zero. When the test temperature is reached, the test piece shall be held at this temperature, allowing sufficient time for the specimen to reach temperature equilibrium. The time allowed for this shall be stated in the test report. The temperature measured by the thermocouple or other measuring device shall not vary during the time of testing by more than ± 2 °C. Apply the test force at the specified rate and record the peak load at fracture. Measure the peak load with an accuracy of ± 1 % or better.

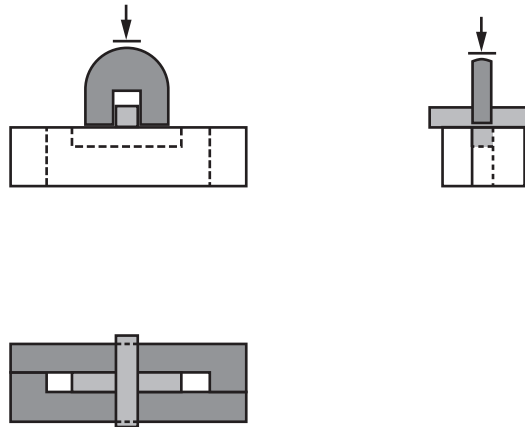

a) Arc-shaped pressure head

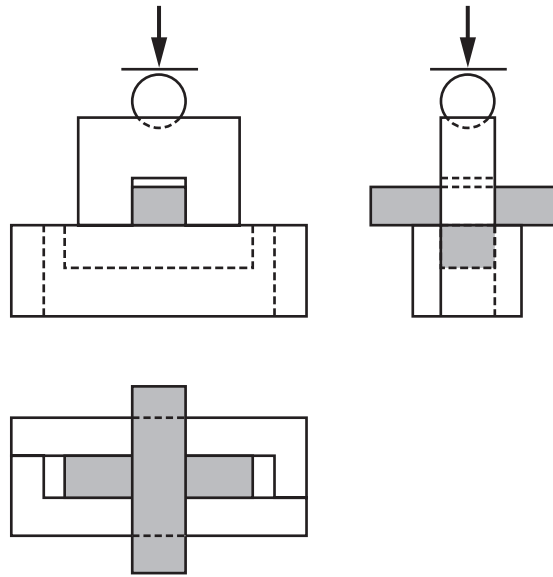

b) Ball-shaped pressure head

Figure 5 — Schematic diagram of cross-bonded sample and fixture for measuring tensile bond strength using arc-shaped pressure head or ball-shaped pressure head

8.5 Measurement of the shear bond strength

To measure the shear bond strength, place each test piece in the fixture, as shown in [Figure 6](#). The upper surface of the fixture shall be close to the interface to avoid the axial centre of load not agreeing with the interface of bonded sample and to keep uniform contact between the pressure head and the sample. The test pieces shall be heated to the set test temperature. Care shall be taken to ensure that the thermal expansion of the furnace does not cause the test piece preload to exceed 5 % of the expected average breaking force; it is preferable that the preload be zero. When the test temperature is reached, the test piece shall be held at this temperature, allowing sufficient time for the specimen to reach temperature equilibrium. The time allowed for this shall be stated in the test report. The temperature measured by the thermocouple or other measuring device shall not vary during the time of testing by more than ± 2 °C. Apply the test force at the specified rate and record the peak load at fracture. Measure the peak load with an accuracy of ± 1 % or better.

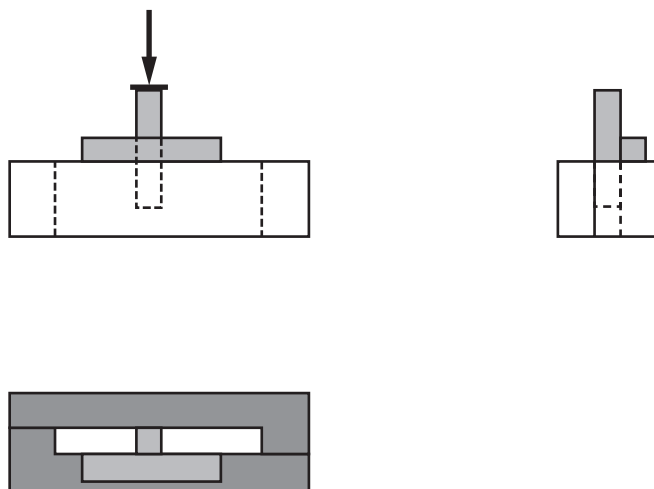

Figure 6 — Schematic diagram of cross-bonded sample and fixture for measuring shear bond strength

9 Calculation of results

9.1 Interfacial tensile bond strength

9.1.1 Standard formula for interfacial tensile bond strength

The standard formula for the interfacial tensile bond strength is:

$$\sigma_t = \frac{P_c}{A_1} \quad (1)$$

where

σ_t is the interfacial tensile bond strength, in megapascals (MPa);

P_c is the maximum load to debond, in newtons (N);

A_1 is the bonded area in tension test, in square millimetres (mm²).

9.1.2 Mean strength and standard deviation for interfacial tensile bond strength

The mean interfacial tensile bond strength, $\bar{\sigma}_t$, and the standard deviation, s , are given by Formulae (2) and (3):

$$\bar{\sigma}_t = \frac{\sum_{i=1}^n \sigma_{t,i}}{n} \quad (2)$$

$$s = \left[\frac{\sum_{i=1}^n (\sigma_{t,i} - \bar{\sigma}_t)^2}{n-1} \right]^{1/2} \quad (3)$$

where

$\sigma_{t,i}$ is the tensile bond strength of the i th test piece;

n is the total number of test pieces.

9.2 Interfacial shear bond strength

9.2.1 Standard formula for interfacial shear bond strength

The standard formula for the interfacial shear bond strength is:

$$\tau = \frac{P_c}{A_2} \quad (4)$$

where

τ is the interfacial shear bond strength, in megapascals (MPa);

P_c is the maximum load to debond, in newtons (N);

A_2 is the bonded area in shear test, in square millimetres (mm²).

9.2.2 Mean strength and standard deviation for interfacial shear bond strength

The mean interfacial shear bond strength, $\bar{\tau}$, and the standard deviation, s , are given by Formulae (5) and (6):

$$\bar{\tau} = \frac{\sum_{i=1}^n \tau_i}{n} \quad (5)$$

$$s = \left[\frac{\sum_{i=1}^n (\tau_i - \bar{\tau})^2}{n-1} \right]^{1/2} \quad (6)$$

where

- τ_i is the shear bond strength of the i th test piece;
- n is the total number of test piece.

10 Test report

The test report shall contain at least the following information:

- a) a reference to this International Standard, i.e. ISO 17095;
- b) the date of the test, unique identification of report and of each page, customer name and address and signatory;
- c) the name and address of the test laboratory;
- d) the test specimen drawing or reference;
- e) the description and test material (material type, manufacturing code, batch number);
- f) a description of the test specimen fabrication process. If a material process is used, report surface roughness/finish on cut or ground surface;
- g) the test temperature; the type of heating element, temperature measuring device;
- h) the furnace environment: air, vacuum or inert atmosphere;
- i) the approximate rate of heating and hold time at the test temperature prior to the test piece test;
- j) the displacement rate, deformation rate or force rate;
- k) the number of tests carried out and the number of valid results obtained;
- l) the valid results, mean value and standard deviations of the interfacial tensile or shear bond strength.

Bibliography

- [1] ISO 14704, *Fine ceramics (advanced ceramics, advanced technical ceramics) — Test method for flexural strength of monolithic ceramics at room temperature*
- [2] BAO Y.W., ZHANG H.B., ZHOU Y.C. A simple method for measuring tensile and shear bond strength for ceramic-ceramic and metal-ceramic joining. *Materials Research Innovations*. 2002, **6** (5-6) pp. 277–280

.....