

---

---

**Wood-based panels — Determination  
of surface soundness**

*Panneaux à base de bois — Détermination de l'arrachement de la  
surface*



Reference number  
ISO 16981:2003(E)

© ISO 2003

**PDF disclaimer**

This PDF file may contain embedded typefaces. In accordance with Adobe's licensing policy, this file may be printed or viewed but shall not be edited unless the typefaces which are embedded are licensed to and installed on the computer performing the editing. In downloading this file, parties accept therein the responsibility of not infringing Adobe's licensing policy. The ISO Central Secretariat accepts no liability in this area.

Adobe is a trademark of Adobe Systems Incorporated.

Details of the software products used to create this PDF file can be found in the General Info relative to the file; the PDF-creation parameters were optimized for printing. Every care has been taken to ensure that the file is suitable for use by ISO member bodies. In the unlikely event that a problem relating to it is found, please inform the Central Secretariat at the address given below.

© ISO 2003

All rights reserved. Unless otherwise specified, no part of this publication may be reproduced or utilized in any form or by any means, electronic or mechanical, including photocopying and microfilm, without permission in writing from either ISO at the address below or ISO's member body in the country of the requester.

ISO copyright office  
Case postale 56 • CH-1211 Geneva 20  
Tel. + 41 22 749 01 11  
Fax + 41 22 749 09 47  
E-mail [copyright@iso.org](mailto:copyright@iso.org)  
Web [www.iso.org](http://www.iso.org)

Published in Switzerland

## Foreword

ISO (the International Organization for Standardization) is a worldwide federation of national standards bodies (ISO member bodies). The work of preparing International Standards is normally carried out through ISO technical committees. Each member body interested in a subject for which a technical committee has been established has the right to be represented on that committee. International organizations, governmental and non-governmental, in liaison with ISO, also take part in the work. ISO collaborates closely with the International Electrotechnical Commission (IEC) on all matters of electrotechnical standardization.

International Standards are drafted in accordance with the rules given in the ISO/IEC Directives, Part 2.

The main task of technical committees is to prepare International Standards. Draft International Standards adopted by the technical committees are circulated to the member bodies for voting. Publication as an International Standard requires approval by at least 75 % of the member bodies casting a vote.

Attention is drawn to the possibility that some of the elements of this document may be the subject of patent rights. ISO shall not be held responsible for identifying any or all such patent rights.

ISO 16981 was prepared by Technical Committee ISO/TC 89, *Wood-based panels*.

ISO 16981 is based on European Standard EN 311.



# Wood-based panels — Determination of surface soundness

## 1 Scope

This International Standard specifies a method for assessing the surface soundness of coated wood-based panels and uncoated particleboards, wet and dry-process fibreboards and cement-bonded particleboards.

NOTE The grid-patterned face (screen side) of hardboards cannot be tested according to this International Standard.

## 2 Normative references

The following referenced documents are indispensable for the application of this document. For dated references, only the edition cited applies. For undated references, the latest edition of the referenced document (including any amendments) applies.

ISO 16999, *Wood-based panels — Sampling and cutting of test pieces*

## 3 Terms and definitions

For the purposes of this document, the following terms and definitions apply.

### 3.1

#### **surface soundness**

strength or quality of bonding between the particles or fibres at the surface of a panel and the material below (uncoated panels) or between the coating material and the underlying panel (coated panels)

## 4 Principle

Square test pieces are cut from the boards to be tested. A shallow circular groove is cut into the surface of the test piece and a steel pad bonded to the area within the groove. The tensile load required to pull this pad from the surface is measured.

## 5 Apparatus

5.1 Milling tool, to produce a circular groove (see Figure 1), within the tolerance specified in 6.2.

Dimensions in millimetres

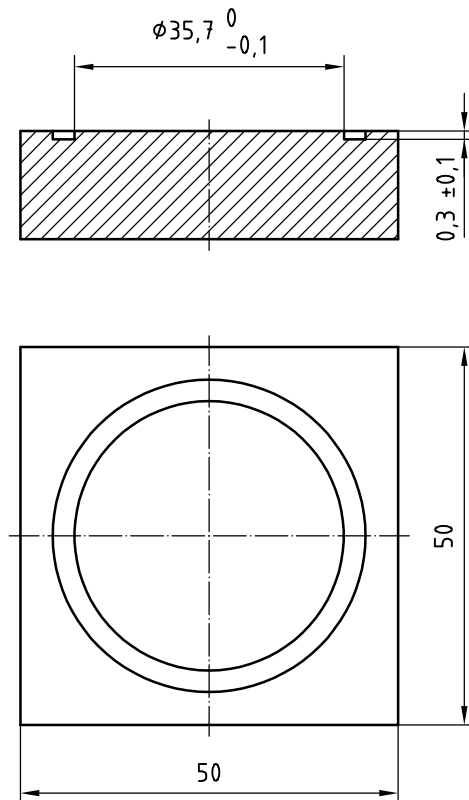

Figure 1 — Circular groove of test piece

5.2 Steel mushroom-shaped pad, as illustrated in Figure 2.

Dimensions in millimetres

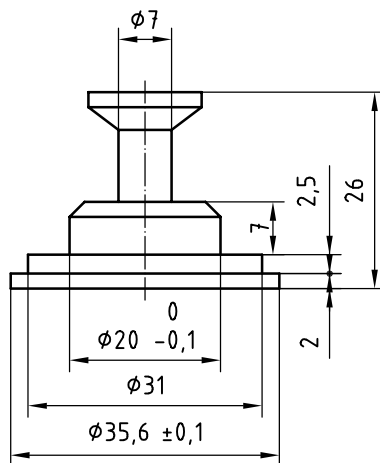
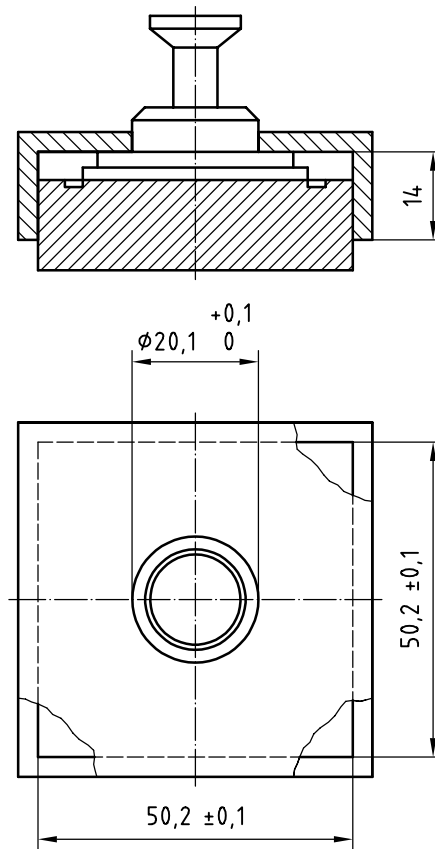

Figure 2 — Steel mushroom-shaped pad

**5.3 Centring frame**, with sufficient stiffness, as specified in Figure 3.

Dimensions in millimetres



**Figure 3 — Centring frame**

**5.4 Tensile-testing machine**, with a sufficient loading capacity, an accuracy of 1 % of the load, and an adjustable velocity of the loading head.

5.5 Gimbal, as illustrated in Figure 4.

Dimensions in millimetres

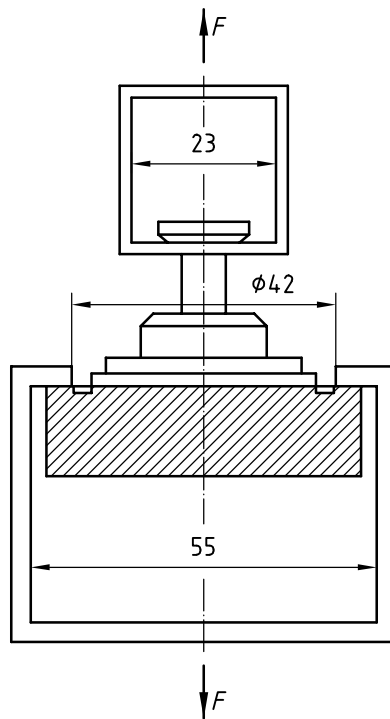

Figure 4 — Gimbal-mounted tensile-testing device

6 Test pieces

6.1 Sampling and cutting

Carry out the sampling and cutting in accordance with ISO 16999.

The test pieces, each 50 mm × 50 mm, shall be taken from each panel to be tested.

6.2 Preparing the groove in the test piece

6.2.1 Uncoated panels

A circular groove, of rectangular cross-section, shall be cut into the surface of the test pieces (see Figure 1) by means of a milling tool (5.1).

For half of the test pieces, this groove shall be on the upper face of the panel and, for the other half, it shall be on the lower face.

The groove shall have an inside diameter of  $35,7 \begin{smallmatrix} 0 \\ -0,1 \end{smallmatrix}$  mm (enclosing an area of 1 000 mm<sup>2</sup>) and a depth of  $(0,3 \pm 0,1)$  mm.



### 6.2.2 Coated panels

A circular groove shall be cut through the coating material so that it just breaks through into the underlying panel. The groove shall not penetrate more than 0,3 mm into this panel. The groove shall have an inside diameter of  $35,7_{-0,1}^0$  mm. If the panel is coated on both sides then, on half of the test pieces, the groove shall be on the upper face of the panel and, on the other half, it shall be on the lower face.

### 6.3 Conditioning

All test pieces shall be conditioned to constant mass in a atmosphere with a relative humidity of  $(65 \pm 5)$  % and a temperature of  $(20 \pm 2)$  °C prior to the bonding of the steel mushroom-shaped pad (5.2) to the surface. Constant mass is considered as having been reached when the results of two successive weighing operations, carried out at an interval of 24 h, do not differ by more than 0,1 % of the mass of the test piece.

## 7 Procedure

### 7.1 Bonding the steel pad to the surface

NOTE 1 The type of adhesive used, the quantity used, and the manner of application can all affect the measured strengths.

In general, use a hot-melt adhesive with a melting point under 150 °C at a maximum application of 0,3 g, spread evenly across the face of the heated steel pad. The centring frame is used to position the pad exactly on the test piece. Whilst in the centring frame, the hot pad shall be pressed onto the surface of the test piece and held with a light pressure until the adhesive has cooled and hardened.

If there can exist a weakening effect to the surface soundness from the heating procedure with hot melts (e.g. in the case of dry-process fibreboards (MDF) or some kinds of coated boards), a coldsetting epoxy adhesive shall be taken instead of the hot melt.

NOTE 2 When testing coated panels, in order to obtain an efficient bond between the steel pad and the surfacing material, it can be necessary to prepare the surface by sanding or solvent cleaning.

NOTE 3 If adhesive flows into the groove, a sharp knife can be used to score through the adhesive around the inner circumference of the groove.

If the panels to be tested are thinner than 15 mm, the test pieces shall be strengthened by bonding a 50 mm × 50 mm steel plate of at least 10 mm thickness to their underside.

If the panels to be tested are thinner than 10 mm, the test pieces may also be strengthened by inserting a steel plate, 50 mm square with a centrally located 40 mm hole, as illustrated in Figure 5, between the gimbal and the test piece (see Figure 6).

Dimensions in millimetres

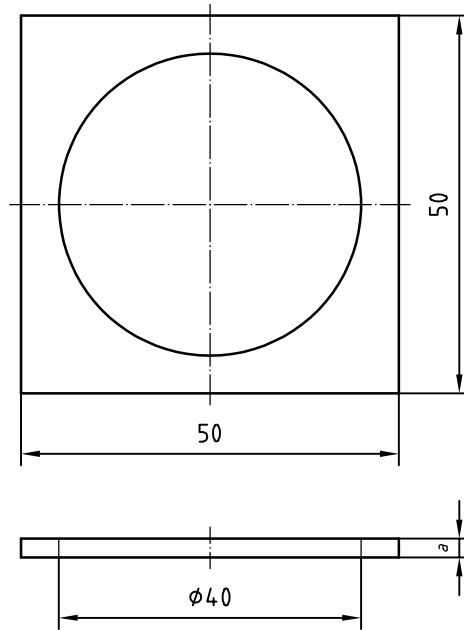

**Key**

$a = 2 \text{ mm to } 3 \text{ mm}$

**Figure 5 — Steel plate for use with test pieces of thickness less than or equal to 10 mm**

Dimensions in millimetres

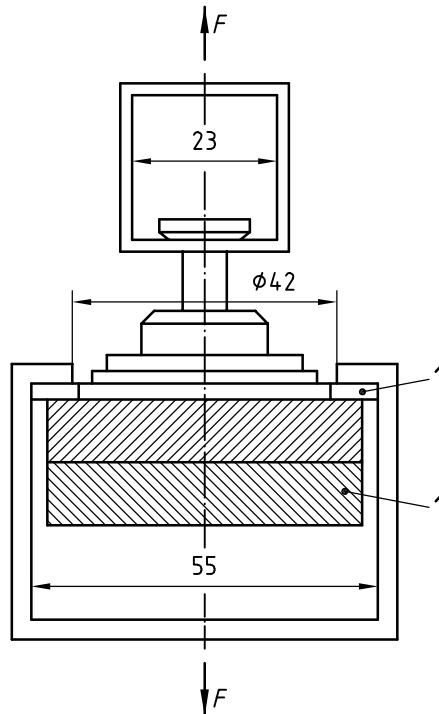

**Key**

1 steel plate

**Figure 6 — Gimbal-mounted tensile-testing device showing steel plate for use with boards of thickness less than or equal to 10 mm**

## 7.2 Determination of force at fracture

After the adhesive has cooled and hardened, the test piece shall be placed in the gimbal (5.5) (see Figures 4 and 6).

The load shall be applied at a constant rate of cross-head movement throughout the test. The rate of loading shall be adjusted so that the maximum load is reached within  $(60 \pm 30)$  s.

Record the force at fracture  $F$ , in newtons, to the nearest 1 N.

For coated panels, also record the location of the failure (within coating, within glueline, between surface material and underlying board, within underlying board). If mixed, the percentage of the different fracture mode should be given, rounded to 10 %.

If test pieces fail within the glueline of the pad, their results shall be rejected.

## 8 Expression of results

The surface soundness  $SS$  for each test piece, in megapascals (MPa), shall be calculated from the equation:

$$SS = F/A$$

where

$F$  is the maximum force, in newtons (N);

$A$  is the surface area given in 6.2.1 (1 000 mm<sup>2</sup>).

Express the result to the nearest 0,01 MPa (N/mm<sup>2</sup>).

## 9 Test report

The test report shall contain the following information:

- a) name and address of test laboratory;
- b) sampling report according to ISO 16999;
- c) date of the test report;
- d) reference to this International Standard;
- e) type and thickness of the panel;
- f) relevant product specification;
- g) surface treatment, if relevant;
- h) specific apparatus used, in case of different possibilities allowed in this International Standard;
- i) test results expressed as stated in Clause 8, calculated and reported separately, the set with the lower mean giving the value of the boards unless its faces are clearly marked;
- j) fracture mode in case of coated panels;
- k) all deviations from this International Standard.

---

---

**ICS 79.060.01**

Price based on 7 pages