**Glass in building — Forced-entry security
glazing —**

Part 4:

**Test and classification by pendulum
impact under thermally and fire stressed
conditions**

Verre dans la construction — Vitrages de sécurité contre infractions —

*Partie 4: Essai et classification par impact pendulaire sous des
conditions de contrainte thermique et de feu*



Reference number
ISO 16936-4:2005(E)

© ISO 2005

PDF disclaimer

This PDF file may contain embedded typefaces. In accordance with Adobe's licensing policy, this file may be printed or viewed but shall not be edited unless the typefaces which are embedded are licensed to and installed on the computer performing the editing. In downloading this file, parties accept therein the responsibility of not infringing Adobe's licensing policy. The ISO Central Secretariat accepts no liability in this area.

Adobe is a trademark of Adobe Systems Incorporated.

Details of the software products used to create this PDF file can be found in the General Info relative to the file; the PDF-creation parameters were optimized for printing. Every care has been taken to ensure that the file is suitable for use by ISO member bodies. In the unlikely event that a problem relating to it is found, please inform the Central Secretariat at the address given below.

© ISO 2005

All rights reserved. Unless otherwise specified, no part of this publication may be reproduced or utilized in any form or by any means, electronic or mechanical, including photocopying and microfilm, without permission in writing from either ISO at the address below or ISO's member body in the country of the requester.

ISO copyright office
Case postale 56 • CH-1211 Geneva 20
Tel. + 41 22 749 01 11
Fax + 41 22 749 09 47
E-mail copyright@iso.org
Web www.iso.org

Published in Switzerland

Contents

Page

Foreword	iv
Introduction	v
1 Scope	1
2 Terms and definitions	1
3 Significance and use	2
4 Sample selection, size, and specimen preparation	2
5 Test methods	3
6 Testing requirements and classification	6
7 Test report	7
Annex A (informative) Test apparatus	8
Bibliography	10

Foreword

ISO (the International Organization for Standardization) is a worldwide federation of national standards bodies (ISO member bodies). The work of preparing International Standards is normally carried out through ISO technical committees. Each member body interested in a subject for which a technical committee has been established has the right to be represented on that committee. International organizations, governmental and non-governmental, in liaison with ISO, also take part in the work. ISO collaborates closely with the International Electrotechnical Commission (IEC) on all matters of electrotechnical standardization.

International Standards are drafted in accordance with the rules given in the ISO/IEC Directives, Part 2.

The main task of technical committees is to prepare International Standards. Draft International Standards adopted by the technical committees are circulated to the member bodies for voting. Publication as an International Standard requires approval by at least 75 % of the member bodies casting a vote.

Attention is drawn to the possibility that some of the elements of this document may be the subject of patent rights. ISO shall not be held responsible for identifying any or all such patent rights.

ISO 16936-4 was prepared by Technical Committee ISO/TC 160, *Glass in building*, Subcommittee SC 2, *Use considerations*.

ISO 16936 consists of the following parts, under the general title *Glass in building — Forced-entry security glazing*:

- *Part 1: Test and classification by repetitive ball drop*
- *Part 2: Test and classification by repetitive impact of a hammer and axe at room temperature*
- *Part 3: Test and classification by manual attack*
- *Part 4: Test and classification by pendulum impact under thermally and fire stressed conditions*

Introduction

ISO 16936 assesses security-glazing products that are more familiarly known as “anti-vandal”, “anti-bandit”, and detention glazing products. Because there is no single test that will cover such a wide range of resistance to attack, four separate test methods are provided to assess the forced entry resistant properties of security glazing. It is not intended that any particular test method be associated with the terms “anti-vandal” or “anti-bandit”, since these terms can be only loosely defined and there is considerable overlap in their definition.

The test methods specified in this part of ISO 16936 do not reproduce the conditions of real human attack, but are intended to provide a means of classifying glazing based on comparative resistance to certain forms of mechanical attack.

.....

Glass in building — Forced-entry security glazing —

Part 4: Test and classification by pendulum impact under thermally and fire stressed conditions

1 Scope

This part of ISO 16936 specifies requirements and mechanical test methods for security glazing designed to resist actions of manual attack by delaying access of objects and/or persons to a protected space for a short period of time. It also classifies security-glazing products into categories of resistance against manual attack under thermally and fire stressed conditions.

NOTE Classifications have not been assigned to specific applications and glazing classification must be specified on an individual basis for every application.

2 Terms and definitions

For the purposes of this document, the following terms and definitions apply.

2.1

action of force

deliberate action on the part of a person made with the intention of creating a hole in the security-glazing product by the use of manually held implements or by the use of thrown objects

2.2

attack face

face of a test piece marked by the manufacturer and/or supplier that is designed to face the attack

2.3

category of resistance

classification of the capability of a security-glazing product to resist actions of force

2.4

performance characteristic

response of the glazing sample in any one of the tests according to this part of ISO 16936

2.5

protected space

space protected against access by the completed installation

2.6

sample

specified number of test pieces which together are representative of the security-glazing product intended to comply with a particular category of resistance specified in ISO 16936

2.7

security-glazing composition

specific construction of a glazing product

NOTE A product is deemed to be of the same or superior security-glazing composition if individual plies are exchanged with others of a different colour, but without significant effect on the resistance to actions of force, and/or additional glazing products are installed on either face of the security-glazing product, laminated to it or with an air space, and/or additional equipment such as alarm wires, heating wires, printing, or surface coatings (on part or all of the surface) are incorporated into the security-glazing product, provided that this does not significantly affect the resistance to actions of force.

2.8

security-glazing product

product based on glass with or without plastics with a single or multiple ply construction, where the individual plies are of uniform thickness over the whole area of the product.

NOTE A security-glazing product is usually transparent or translucent, and provides a specific resistance to the actions of force.

2.9

test piece

specified piece of security-glazing product submitted to a specified test procedure

3 Significance and use

IMPORTANT — Security-glazing products should be installed in a frame which can give appropriate resistance to impact and which also provides a suitable support for the security-glazing product. Cut-outs and holes in security-glazing products should be avoided where possible, as these can affect the resistance of the product.

The test methods given in this part of ISO 16936 aid in assigning a level of physical security to glazing used in window and door assemblies based upon objective tests which can be consistently duplicated.

These test methods evaluate the resistance of security glazing to attacks using blunt and sharp impact devices and fire. The test methods evaluate the performance of glazing in hot and cold environments, but do not provide a measure of the resistance or performance of glazing subjected to attack by ballistics, chemical agents, explosives or other extreme methods of attack. Where such elements are a factor, consult the manufacturer.

4 Sample selection, size, and specimen preparation

4.1 The sample submitted for testing shall consist of three test pieces one for each test.

NOTE To ensure against invalid test results because of errors during the test, it is advisable to submit at least one extra test piece.

4.2 Each test piece shall be $(1\ 100 \pm 5)$ mm long \times (900 ± 5) mm wide. The edges shall be free from visible chips, cracks and flaws. Glass samples should be lightly arressed for ease of handling.

4.3 Figure A.1 shows an acceptable test fixture sketch and the location of the strike points specified in Tables 1 and 2.

4.4 For non-symmetrical materials, the attack face of the product shall be identified by the manufacturer and attacked during the test process.

5 Test methods

5.1 Low-temperature impact test

5.1.1 General

This test is designed to evaluate the capability of security glazing to resist repeated impact forces from both a blunt and a sharp impactor under cold temperature conditions. This test is intended to closely simulate a sustained battering ram style or pounding type attack and provide an evaluation of the capability of the glazing to prevent, delay, or frustrate penetration and access to unauthorized areas under cold temperature conditions. An impact test of this design performed on security glazing evaluates the impact strength of the glazing and its components as well as the quality of fabrication techniques.

5.1.2 Test apparatus

5.1.2.1 Large blunt impactor, consisting of a hinged or pivoted system with a mass of 36,3 kg capable of delivering impacts of 270 J to a glazing specimen mounted in a frame assembly, with a striking surface made from C1010-C1020 carbon steel and having a striking surface of $100 \pm 2 \text{ mm}^2$ with rounded edges similar to a 4,5 kg sledgehammer head. See Figure A.4.

5.1.2.2 Sharp impactor, consisting of a hinged or pivoted system with a mass of 36,3 kg capable of delivering impacts of 135 J to a glazing specimen mounted in a frame assembly, with a striking surface made from C1010-C1020 carbon steel and the sharpness of the impacting point similar to the end of a new fireman's axe at the beginning of a test sequence. See Figure A.3.

5.1.2.3 Test frame, see Figure A.1. Test frames of alternative designs may be used provided the same test parameters are evaluated.

5.1.3 Test procedure

5.1.3.1 Conditioning

Condition the panel at $-25 \text{ °C} \pm 3 \text{ °C}$ for a period of not less than 4 h. The protected surface temperature shall be maintained $-25 \text{ °C} \pm 3 \text{ °C}$ during the test until an opening is created.

5.1.3.2 Installation

Install the panel into the test fixture with a minimum $30 \pm 5 \text{ mm}$ edge engagement. Appropriate gasket material shall be used to keep glazing material from contacting the frame. Refer to the manufacturer's recommendations.

5.1.3.3 Test protocol

Using the test apparatus in accordance with 5.1.2, begin a series of strikes against the centre of the panel for the number of required impacts, first with the blunt impactor followed by the sharp impactor on the pendulum. The strikes shall be uniformly made with $9 \text{ s} \pm 1 \text{ s}$ intervals. Changing of blunt and sharp impactor during the test shall not exceed 90 s. During the test, reposition the pendulum as necessary to produce the maximum possible duress on the panel, leading to panel failure. Record the number of strikes required to produce the first penetration of the panel, and the number of strikes required to produce an opening large enough to pass a $130 \text{ mm} \times 200 \text{ mm}$ rigid rectangular box with no more than 45 N force.

NOTE The required pendulum drop height can be computed from the impact energy required.

5.1.3.4 Test termination

Terminate the test after the required number of impacts, or when an opening in the test panel large enough to pass the 130 mm × 200 mm rigid rectangular object with no more than 45 N force is produced, whichever occurs first. Record the size of the opening to the nearest 6 mm at test termination.

5.2 High-temperature impact test

5.2.1 General

This test is designed to evaluate the capability of security glazing to resist repeated impact forces from both a blunt and sharp impactor under warm temperature conditions. This test is intended to closely simulate a sustained battering ram style or pounding type attack and provide an evaluation of the capability of the glazing to prevent, delay, or frustrate penetration and access to unauthorised areas under warm temperature conditions. An impact test of this design performed on security glazing evaluates the impact strength of the glazing and its components as well as the quality of fabrication techniques

5.2.2 Test apparatus

5.2.2.1 Large blunt impactor, consisting of a hinged or pivoted system with a mass of 36,3 kg capable of delivering impacts of 270 J to a glazing specimen mounted in a frame assembly. The striking surface of the impactor shall be made from C1010-C1020 carbon steel and have a striking surface of $100 \pm 2 \text{ mm}^2$ with rounded edges similar to a 4,5 kg sledgehammer head. See Figure A.4.

5.2.2.2 Sharp impactor, consisting of a hinged or pivoted system with a mass of 36,3 kg capable of delivering impacts of 135 J to a glazing specimen mounted in a frame assembly. The striking surface of the impactor shall be made from C1010-C1020 carbon steel and the sharpness of the impacting point shall be similar to the end of a new fireman's axe at the beginning of a test sequence. See Figure A.3.

5.2.2.3 Test frame, see Figure A.1. Test frames of alternative designs may be used provided the same test parameters are evaluated

5.2.3 Test procedure

5.2.3.1 Conditioning

Condition the panel at $50 \text{ °C} \pm 3 \text{ °C}$ for a period of not less than 4 h. The protected surface temperature shall be maintained $50 \text{ °C} \pm 3 \text{ °C}$ during the test until an opening is created.

5.2.3.2 Installation

Install the panel into the test fixture with a minimum $30 \pm 5 \text{ mm}$ edge engagement. Appropriate gasket material shall be used to keep glazing material from contacting the frame. Refer to the manufacturer's recommendations.

5.2.3.3 Test protocol

Using the test apparatus in accordance with 5.2.2, begin a series of strikes against the centre of the panel for the number of required impacts, first with the blunt impactor followed by the sharp impactor on the pendulum. The strikes shall be uniformly made with $9 \text{ s} \pm 1 \text{ s}$ intervals. Changing of blunt and sharp impactor during the test shall not exceed 90 s. During the test, reposition the pendulum as necessary to produce the maximum possible duress on the panel, leading to panel failure. Record the number of strikes required to produce the first penetration of the panel, and the number of strikes required to produce an opening large enough to pass a 130 mm × 200 mm rigid rectangular box with no more than 45 N force.

NOTE The required pendulum drop height can be computed from the impact energy required.

5.2.3.4 Test termination

Terminate the test after the required impacts, or when an opening in the test panel large enough to pass the 130 mm × 200 mm rigid rectangular object with no more than 45 N force is produced, whichever occurs first. Record the size of the opening to the nearest 6 mm at test termination.

5.3 Torch and small blunt impactor test

5.3.1 General

This test is designed to evaluate the capability of security glazing to withstand a sustained flame attack in conjunction with repeated impact forces from a blunt impactor. This test is intended to simulate a sustained flame attack used in conjunction with an impact object that is similar in nature to a ball peen hammer that will break away glass so that the flame will contact plastic core or interlayer material and continue to damage plastic as it burns. A flame/impact test of this design performed on security glazing evaluates the flame resistance and impact strength of the glazing and its components, as well as the quality of fabrication techniques.

5.3.2 Test apparatus

5.3.2.1 Small blunt impactor, consisting of a hinged or pivoted system with a mass of 10 kg capable of delivering impacts of 84 J to a glazing specimen mounted in a frame assembly, with a striking surface made from C1010-C1020 carbon steel and having a round impact surface of 16 mm radius. See Figure A.2.

5.3.2.2 Propane torch producing a blue flame of 980 °C to 1 100 °C and set so as to strike the panel at the proposed impact location at an angle of 60 ° from the panel face and at a 50 mm stand-off distance.

5.3.2.3 Test frame, see Figure A.1. Test frames of alternative designs may be used provided the same test parameters are evaluated.

5.3.3 Test procedure

5.3.3.1 Conditioning

Condition the panel for 4 h minimum at 23 °C ± 3 °C.

5.3.3.2 Installation

Install the panel into the test fixture with a minimum 30 ± 5 mm edge engagement. Appropriate gasket material shall be used to keep glazing material from contacting the frame. Refer to the manufacturer's recommendations.

5.3.3.3 Test protocol

Using the test apparatus in accordance with 5.3.2, start the propane torch and begin measuring the elapsed time. Start the series of strikes at the centre of the panel after 9 s ± 1 s. Continue impacting at 9 s ± 1 s intervals until the required number of impacts is reached. During the test, reposition the pendulum and torch as necessary to produce the maximum possible duress on the panel, leading to failure. Record the number of strikes required to produce the first penetration of the panel, and the number of strikes along with the duration of the flame exposure required to produce an opening large enough to pass a 130 mm × 200 mm rigid rectangular box with no more than 45 N force. If the impactor becomes stuck in the panel, it shall be removed within 60 s. If the impactor cannot be removed in 60 s, the test shall be considered invalid. After removal of the impactor from the panel within 60 s, any impacts missed shall be made up at an accelerated rate not to exceed 1 every 4,5 s.

NOTE The required pendulum drop height can be computed from the impact energy required.

5.3.3.4 Test termination

Terminate the test after the required impacts, or when an opening in the test panel large enough to pass the 130 mm × 200 mm rigid rectangular with no more than 45 N force is produced, whichever occurs first. After extinguishing the flame, the softened material should be prevented from sagging into the opening. Record the size of the opening to the nearest 13 mm at test termination.

6 Testing requirements and classification

The product tested shall be classified based upon its ability to meet or exceed all testing requirements for all three tests, as defined in 5.1, 5.2, and 5.3 and presented in Tables 1 and 2 for a particular category of resistance.

When testing for a specific category of resistance, if a product fails to reach that level, but meets or exceeds a lower level, it shall be rated at that lower level.

The test protocol described in Table 1 is to be carried out on both hot and cold conditioned samples.

Table 1 — Testing and classification

Category of resistance	Total time ^a min	Sequence and number of impacts			Code designation
		1	2	3	
		Blunt impactor	Sharp impactor	Blunt Impactor	
P1D	4	10	20	10	ISO ... P1D
P2D	10	25	50	25	ISO ... P2D
P3D	20	50	100	50	ISO ... P3D
P4D	40	100	200	100	ISO ... P4D
P5D	60	150	300	150	ISO ... P5D

^a The element of time is hypothetical and is offered solely as a design suggestion. The element of time is based on the assumption that sustained manpower can deliver 400 blows of 270 J each in 40 min. Since 400 blows is the number of impacts a security-glazing sample meeting category of resistance P4D must absorb and still be operational, in accordance with 5.1.2 or 5.2.2, it is assumed failure of the security-glazing sample meeting Category of Resistance P4D will occur after 40 min.

Table 2 — Torch and small blunt impactor test criteria

Category of resistance	Blunt impacts ^a	Code designation
P1D	20	ISO ... P1D
P2D	50	ISO ... P2D
P3D	75	ISO ... P3D
P4D	100	ISO ... P4D
P5D	150	ISO ... P5D

^a To be performed on a sample conditioned for 4 h min. at 23 °C ± 3 °C (heated in the centre by propane torch).

7 Test report

The following items shall be included in the test report:

- name and address of the testing laboratory;
- date the laboratory completed testing;
- name and address of glazing manufacturer;
- description of identifying markings on all components of test assembly;
- diagrams, details, and photographs of testing equipment;
- specification and makeup of glazing assemblies including thickness, weight, composition and product model number(s) and test orientation of non-symmetrical test samples;
- all test data;
- classification rating of the product.

Optionally, the following photographic records may be provided if available:

- a videotape recording of the entire test from inception of the physical test to product failure or termination of the test;
- colour photographs of the salient stages of the test, such as initial penetration, product failure, and the condition of the sample at the conclusion of the test.

Annex A
(informative)

Test apparatus

Figures A.1 to A.4 show the test fixtures necessary for carrying out the test methods according to 5.1, 5.2, and 5.3. Test fixtures of alternative design may be used provided the same test parameters are evaluated.

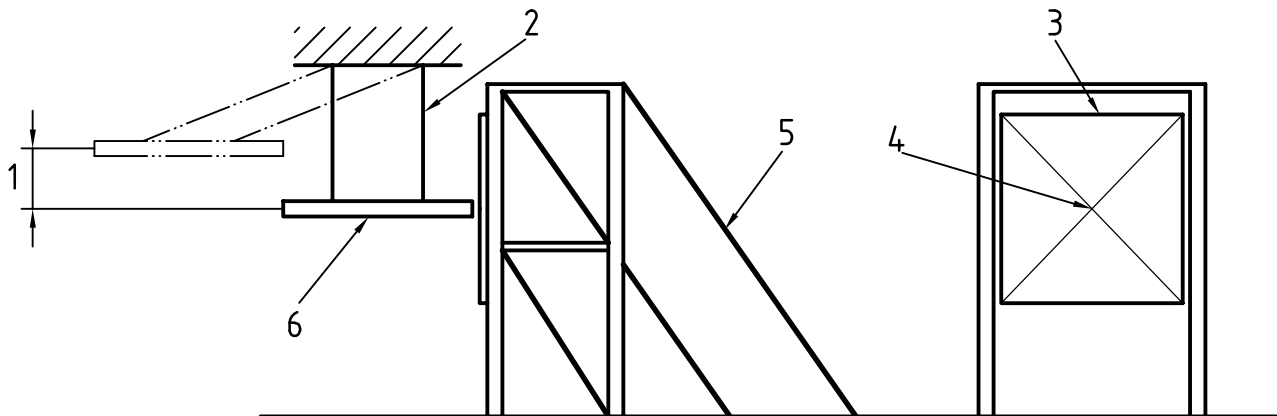

Key

- 1 variable drop height
- 2 parallel cables
- 3 900 × 1 100 mm test piece
- 4 strike point
- 5 angle bracing
- 6 impact ram (see Figures A.2 to A.4)

Figure A.1 — Test assembly

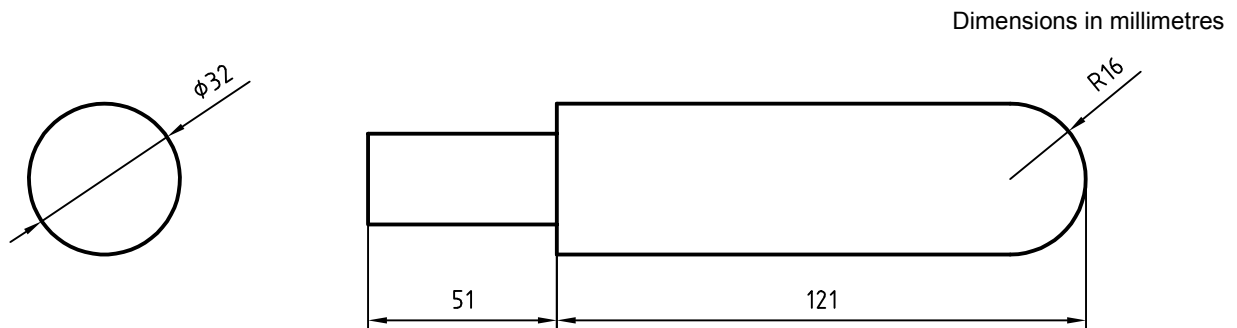

Figure A.2 — Small blunt impactor

Dimensions in millimetres

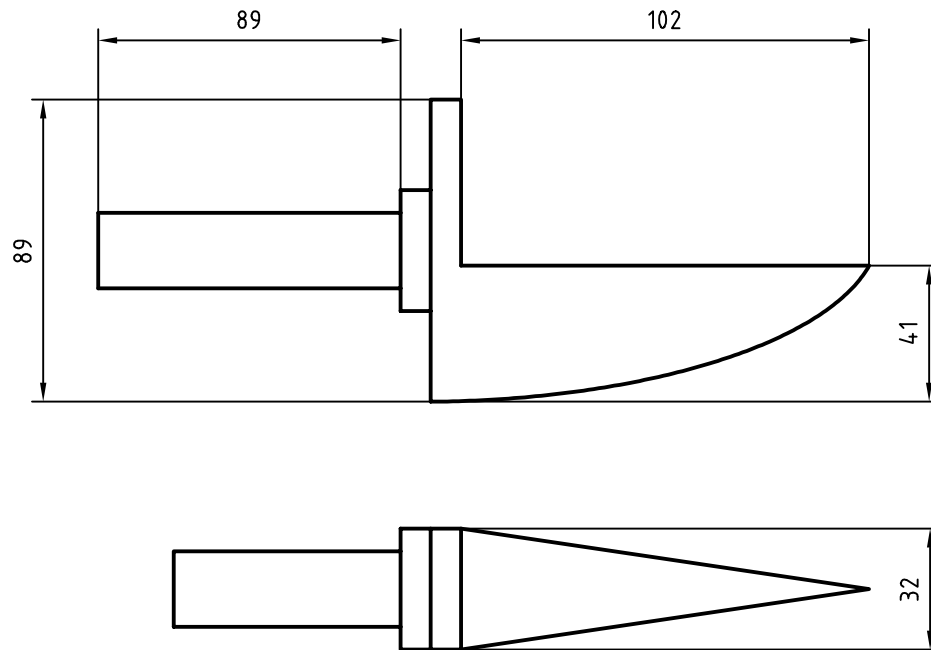
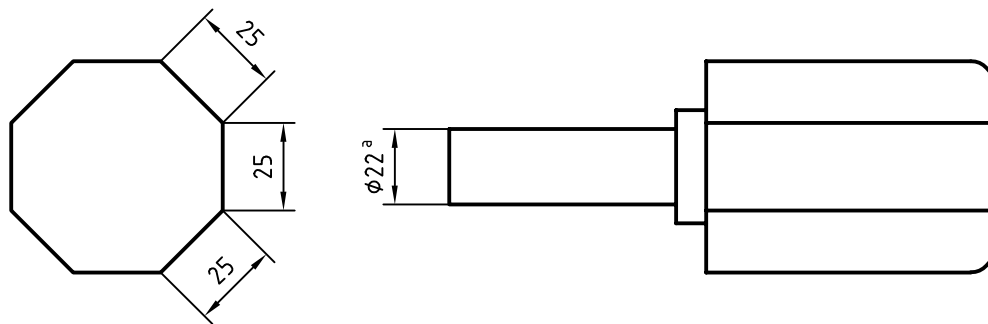

Figure A.3 — Sharp impactor

Dimensions in millimetres



^a Bolt (typical).

Figure A.4 — Large blunt impactor

Bibliography

- [1] ASTM 1915, *Standard Test Methods for Glazing for Detention Facilities*

00000000000000000000000000000000

ICS 81.040.20

Price based on 10 pages