**Respiratory protective devices —
Methods of test and test equipment —**

Part 2:

Determination of breathing resistance

*Appareils de protection respiratoire — Méthodes d'essai et équipement
d'essai —*

Partie 2: Détermination de la résistance respiratoire



Reference number
ISO 16900-2:2009(E)

PDF disclaimer

This PDF file may contain embedded typefaces. In accordance with Adobe's licensing policy, this file may be printed or viewed but shall not be edited unless the typefaces which are embedded are licensed to and installed on the computer performing the editing. In downloading this file, parties accept therein the responsibility of not infringing Adobe's licensing policy. The ISO Central Secretariat accepts no liability in this area.

Adobe is a trademark of Adobe Systems Incorporated.

Details of the software products used to create this PDF file can be found in the General Info relative to the file; the PDF-creation parameters were optimized for printing. Every care has been taken to ensure that the file is suitable for use by ISO member bodies. In the unlikely event that a problem relating to it is found, please inform the Central Secretariat at the address given below.



COPYRIGHT PROTECTED DOCUMENT

© ISO 2009

All rights reserved. Unless otherwise specified, no part of this publication may be reproduced or utilized in any form or by any means, electronic or mechanical, including photocopying and microfilm, without permission in writing from either ISO at the address below or ISO's member body in the country of the requester.

ISO copyright office
Case postale 56 • CH-1211 Geneva 20
Tel. + 41 22 749 01 11
Fax + 41 22 749 09 47
E-mail copyright@iso.org
Web www.iso.org

Published in Switzerland

Contents

Page

Foreword	iv
Introduction	v
1 Scope	1
2 Normative references	1
3 Terms and definitions	1
4 Prerequisites	2
5 General test requirements	2
6 Method 1: Static breathing resistance	2
6.1 Principle	2
6.2 Equipment	2
6.3 Procedure	3
7 Method 2: Dynamic breathing resistance	7
7.1 Principle	7
7.2 Equipment	7
7.3 Procedure	8
8 Test report	8
9 Uncertainty of measurement	8
Annex A (normative) Application of uncertainty of measurement	9
Annex B (normative) Fitting procedure for hoods which seal around the neck and which may or may not incorporate a head harness	11

Foreword

ISO (the International Organization for Standardization) is a worldwide federation of national standards bodies (ISO member bodies). The work of preparing International Standards is normally carried out through ISO technical committees. Each member body interested in a subject for which a technical committee has been established has the right to be represented on that committee. International organizations, governmental and non-governmental, in liaison with ISO, also take part in the work. ISO collaborates closely with the International Electrotechnical Commission (IEC) on all matters of electrotechnical standardization.

International Standards are drafted in accordance with the rules given in the ISO/IEC Directives, Part 2.

The main task of technical committees is to prepare International Standards. Draft International Standards adopted by the technical committees are circulated to the member bodies for voting. Publication as an International Standard requires approval by at least 75 % of the member bodies casting a vote.

Attention is drawn to the possibility that some of the elements of this document may be the subject of patent rights. ISO shall not be held responsible for identifying any or all such patent rights.

ISO 16900-2 was prepared by Technical Committee ISO/TC 94, *Personal safety — Protective clothing and equipment*, Subcommittee SC 15, *Respiratory protective devices*.

ISO 16900 consists of the following parts, under the general title *Respiratory protective devices — Methods of test and test equipment*:

- *Part 1: Determination of inward leakage*
- *Part 2: Determination of breathing resistance*
- *Part 3: Determination of particle filter penetration*
- *Part 4: Determination of gas filter capacity*

Introduction

This part of ISO 16900 is intended as a supplement to the relevant performance standards for respiratory protective devices. Test methods are specified for complete devices or parts of devices. If deviations from the test method given in this part of ISO 16900 are necessary, these deviations will be specified in the relevant performance standard.

© 2010 International Organization for Standardization

Respiratory protective devices — Methods of test and test equipment —

Part 2: Determination of breathing resistance

1 Scope

This part of ISO 16900 specifies the method(s) of test for breathing resistance for:

- complete respiratory protective devices ¹⁾;
- filters for respiratory protective devices;
- respiratory interfaces.

2 Normative references

The following referenced documents are indispensable for the application of this document. For dated references, only the edition cited applies. For undated references, the latest edition of the referenced document (including any amendments) applies.

ISO 16972, *Respiratory protective devices — Terms, definitions, graphical symbols and units of measurement*

ISO/TS 21748:2004, *Guidance for the use of repeatability, reproducibility and trueness estimates in measurement uncertainty estimation*

3 Terms and definitions

For the purposes of this document, the terms and definitions given in ISO 16972 apply together with the following.

3.1

static breathing resistance

differential pressure caused by an RPD when the breathing gas is passed through the device at a constant flow

3.2

dynamic breathing resistance

differential pressure caused by an RPD when the breathing gas is delivered by a breathing machine adjusted to a specified breathing minute volume and waveform

1) Respiratory protective device = RPD.

4 Prerequisites

In order to implement this part of ISO 16900, at least the following parameters need to be specified in the performance standard:

- the number of specimens;
- the selection and type(s) of support such as dummy head/dummy torso;
- any prior conditioning or testing;
- flow rate (static test method);
- breathing minute volume and waveform (dynamic test method);
- test method;
- any deviations from the method(s).

5 General test requirements

Unless otherwise specified, the values stated in this part of ISO 16900 are expressed as nominal values. Except for temperature limits, values which are not stated as maxima or minima shall be subject to a tolerance of $\pm 5\%$. Unless otherwise specified, the ambient temperature for testing shall be between 16 °C and 32 °C and 50 % \pm 30 % RH. Any temperature limits specified shall be subject to an accuracy of $\pm 1^\circ\text{C}$.

6 Method 1: Static breathing resistance

6.1 Principle

The device is mounted on a support as described in the performance standard, and air is drawn through the device at a constant flow.

NOTE The convention of reporting breathing resistance is that if, during the inhalation resistance test, the pressure inside the facepiece relative to atmosphere is negative, no sign is used in front of the result. If the relative pressure inside the facepiece is positive, the result is prefixed with a '+’.

6.2 Equipment

6.2.1 Pressure gauge, calibrated in the appropriate range relevant to the performance standard.

6.2.2 Flowmeter(s), calibrated in the appropriate volumetric flow rate range and corrected for the ambient temperature and ambient atmospheric pressure during use.

6.2.3 Ambient temperature and ambient atmospheric pressure measuring equipment.

6.2.4 Regulated blower/compressed air source and/or a variable suction device.

6.2.5 Support for the device, (e.g. filter holder, dummy head or dummy torso) as described in the performance standard.

NOTE It is important that the holder of the filter or facepiece does not reduce the effective working area of the filter or facepiece.

6.3 Procedure

6.3.1 Procedure for filters for respiratory protective devices

The method draws air through the filter holding system (see Figure 1) and the pressure drop, between ambient and a pressure port fitted at a suitable point between the support system and the connection to the suction device, is measured.

Ensure that the filter has been pre-conditioned according to the performance standard and that an equipment connector, or the holder intended by the manufacturer, is available.

Mount the filter in a leaktight manner as indicated in Figure 1. Draw the appropriate airflow, as specified in the performance standard, through the filter support system. Measure and record the pressure drop, Δp_F , across the support system.

Remove the filter. Draw the same airflow through the filter holding system. Measure and record the pressure drop, Δp_H , of the set-up.

Report the breathing resistance of the filter at the flow rate as: $\Delta p_F - \Delta p_H$.

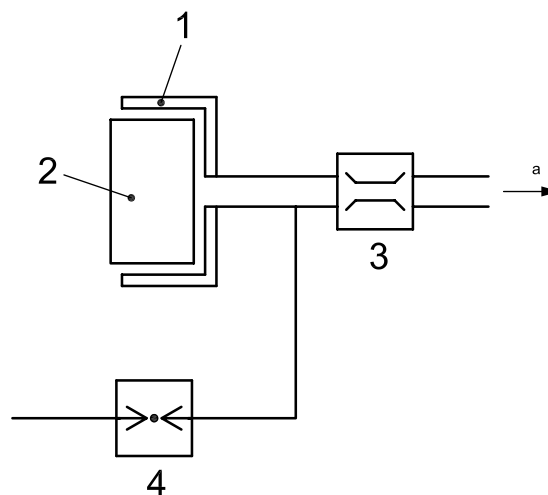

Key

- 1 filter support
- 2 filter
- 3 flow meter
- 4 pressure gauge
- a Regulated suction.

Figure 1 — Examples of arrangement for measurement of breathing resistance of filters

6.3.2 Procedure for complete respiratory protective devices and respiratory interfaces

6.3.2.1 General

Ensure that the device has been pre-conditioned according to the performance standard.

Determine the pressure offset of the support system at the relevant flow rate. The measured resistance of the complete system shall be corrected for the offset.

Fit the respiratory interface of the device on the dummy head (see Figure 2) or dummy torso as defined by the performance standard (see Figure 3), ensuring leak tightness, but without deformation. This may involve the use of a sealant.

For hoods fitting around the neck, the fitting procedure given in Annex B (see Figure B.1) shall be used.

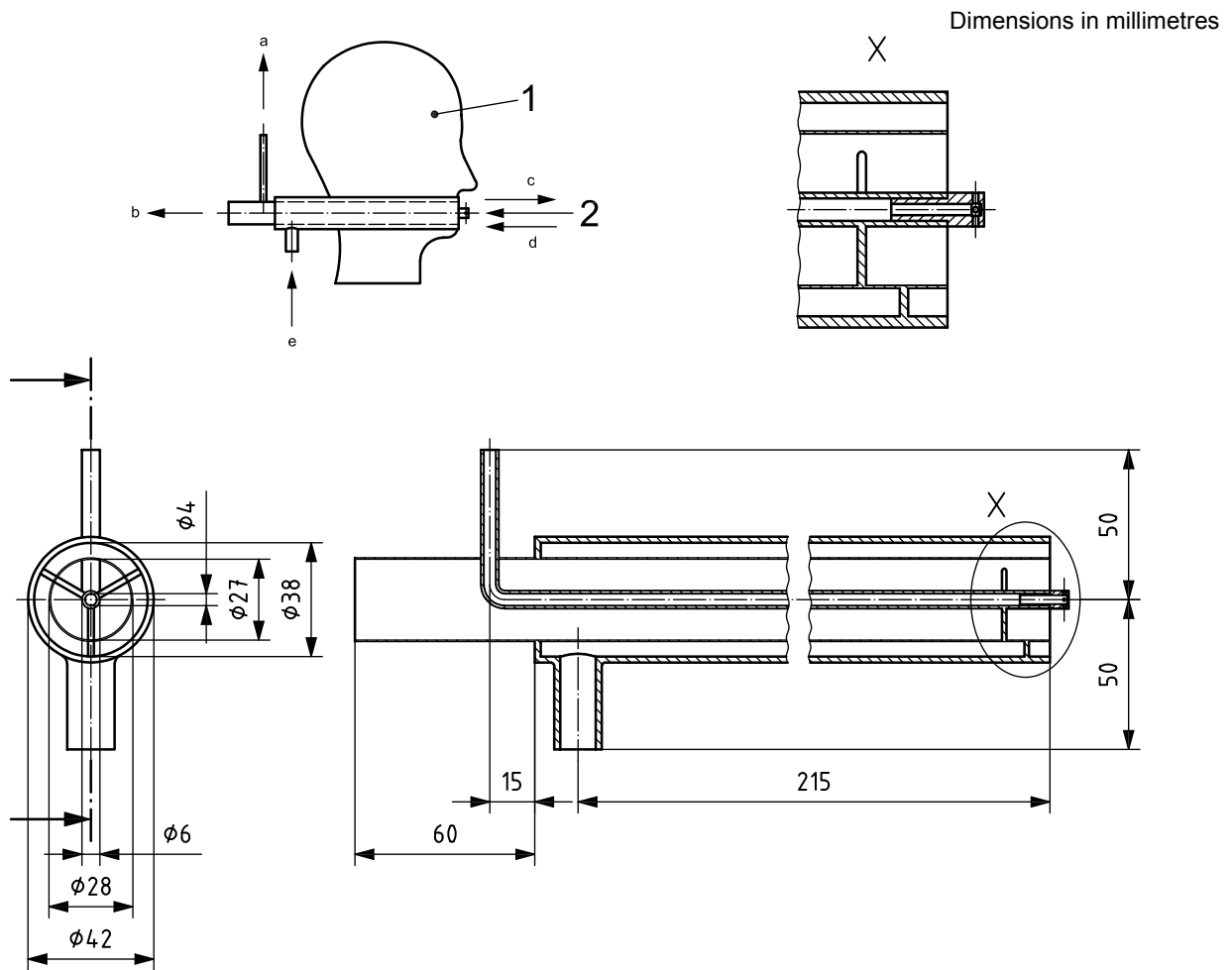

Key

- 1 dummy head
- 2 pressure port with button probe (see Figure 4)
- a To pressure gauge.
- b To breathing machine/suction device, inhalation.
- c Exhaled air.
- d Inhaled air.
- e From breathing machine/blower, exhalation.

Figure 2 — Required dimension and a typical arrangement of tubes in dummy head for measurement of breathing resistance

Dimensions in millimetres

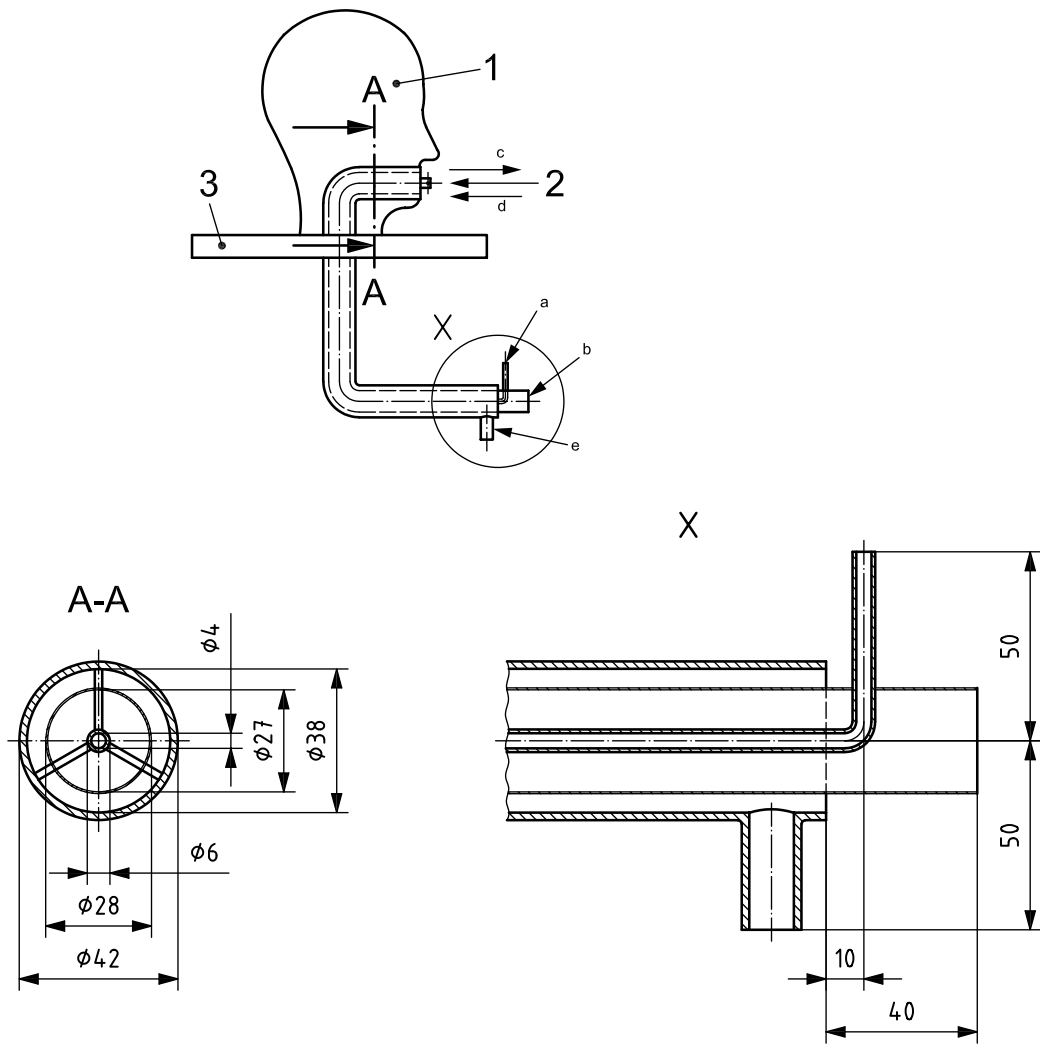

Key

- 1 dummy torso
- 2 pressure port with button probe (see Figure 4)
- 3 adjustable flow collar (see Figure B.1)
- a To pressure gauge.
- b To breathing machine/suction device, inhalation.
- c Exhaled air.
- d Inhaled air.
- e From breathing machine/blower, exhalation.

Figure 3 — Required dimension and a typical arrangement of tubes in dummy torso for measurement of breathing resistance for hoods sealing around the neck

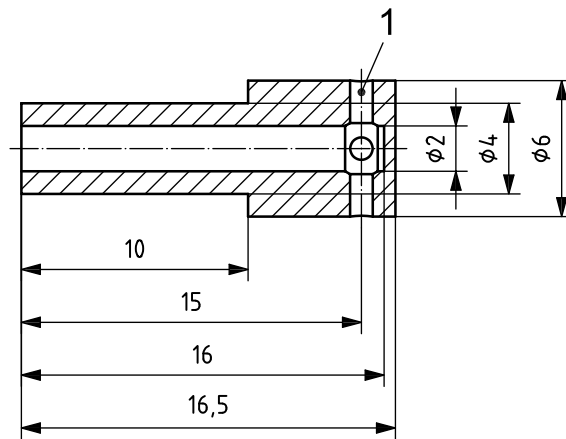
**Key**

1 two holes \varnothing 1 mm at 90° orientation

Figure 4 — Details of button probe as shown in Figures 2 and 3

6.3.2.2 Inhalation resistance

For measurements of inhalation resistance, connect the inhalation tube to a suitable suction device and the pressure gauge connections to the pressure port and ambient air. Close off the tube for exhalation air, as shown in Figures 2 and 3.

Switch on and adjust the suction device to give the appropriate flow, operate the device as described in the performance standard and record the peak pressure.

With the support upright and facing directly ahead, record the reading corrected for the offset, as the inhalation resistance. If an inhalation valve is fitted, measure the inhalation resistance with the support in each of the following four additional orientations:

- a) facing vertically, upwards;
- b) facing vertically, downwards;
- c) lying on the left side;
- d) lying on the right side.

6.3.2.3 Exhalation resistance

For measurements of exhalation resistance, connect the exhalation tube to a suitable blower and the pressure gauge connections to the pressure port and ambient air. Close off the tube for inhalation air as shown in Figures 2 and 3.

Switch on and adjust the blowing device to give the appropriate flow, operate the device as described in the performance standard and record the pressure.

With the support upright and facing directly ahead, record the reading corrected for the offset, as the exhalation resistance. If an exhalation valve is fitted measure the exhalation resistance with the support in each of the following four additional orientations:

- a) facing vertically, upwards;
- b) facing vertically, downwards;
- c) lying on the left side;
- d) lying on the right side.

7 Method 2: Dynamic breathing resistance

7.1 Principle

The device is mounted on a support as described in the performance standard and connected to a breathing machine adjusted to a specified breathing minute volume and waveform.

NOTE The convention of reporting breathing resistance is that if, during the inhalation resistance test, the pressure inside the facepiece relative to atmosphere is negative, no sign is used in front of the result. If the relative pressure inside the facepiece is positive, the result is prefixed with a '+’.

7.2 Equipment

7.2.1 Breathing machine, set to minute volume and waveform characteristics specified in the performance standard.

7.2.2 Support, as described in the performance standard, e.g. dummy head with insert or torso with insert (see Figures 2, 3 and 4).

7.2.3 Pressure gauge and recording device, calibrated in the appropriate range to the performance standard.

The response time of this pressure gauge, including the recording device, shall be less than 30 ms for a response of 10 % to 90 % of the full scale deflection of the range used.

7.3 Procedure

7.3.1 General

Ensure that the device has been pre-conditioned in accordance with the performance standard. Adjust the breathing machine to give the breathing minute volume and waveform specified in the performance standard. Connect one port of the pressure gauge to the pressure port of the support for the device and the other port to ambient air. Connect the pressure gauge to the recording device.

Fit the device on the support, ensuring leak tightness, but without deformation (this may involve the use of a sealant). For hoods sealing around the neck, the fitting procedure given in Annex B (see Figure B.1) shall be used. Note the "zero" reading of the pressure gauge background fixture only. Switch on the breathing machine and operate the device as defined in the performance standard and record the peak pressure.

7.3.2 Inhalation and exhalation resistance

Record the peak pressure on inhalation and exhalation. Record the reading corrected for the 'zero' reading, as the inhalation and exhalation resistance at each one of the orientations defined below.

For non-valved devices, measure the inhalation and exhalation resistance with the support upright and facing directly ahead.

For valved devices, measure the inhalation and exhalation resistance with the support in each of the five defined orientations:

- a) upright and facing directly ahead;
- b) facing vertically, upwards;
- c) facing vertically, downwards;
- d) lying on the left side;
- e) lying on the right side.

8 Test report

The test report shall include information regarding those parameters specified in Clause 4, together with the measured breathing resistances.

9 Uncertainty of measurement

An estimate of the uncertainty of measurement associated with this method of test shall be established, as described in ISO/TS 21748:2004. The value of this estimate shall not exceed $\pm 10\%$.

NOTE The use of transfer standards might assist in establishing common uncertainties of measurement between laboratories.

Annex A (normative)

Application of uncertainty of measurement

A.1 Determination of compliance

In order to determine compliance or otherwise of the measurement made in accordance with this test method, when compared to the specification limits given in the performance standard, the following protocol shall be applied.

If the test result plus/minus the uncertainty of measurement, U , falls completely inside or outside the specification zone for the particular test given in the performance standard, then the result shall be deemed to be a straightforward pass or fail (see Figures A.1 and A.2).

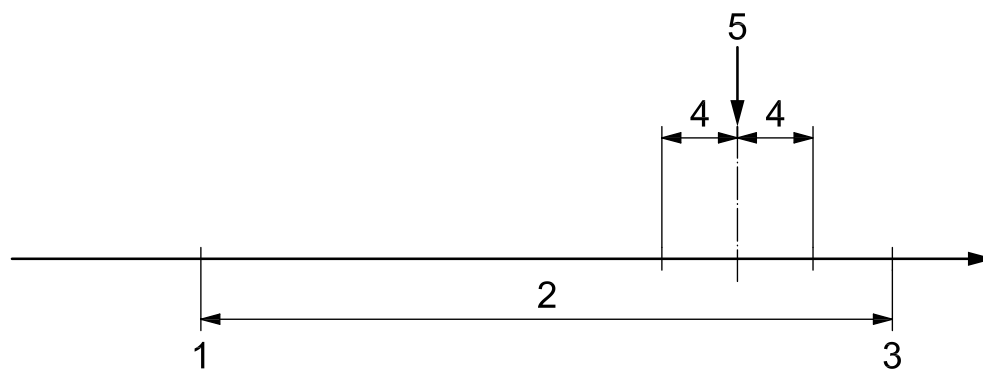

Key

- 1 lower specification limit (LSL)
- 2 specification zone
- 3 upper specification limit (USL)
- 4 uncertainty of measurement (U)
- 5 measured value

Figure A.1 — Result pass

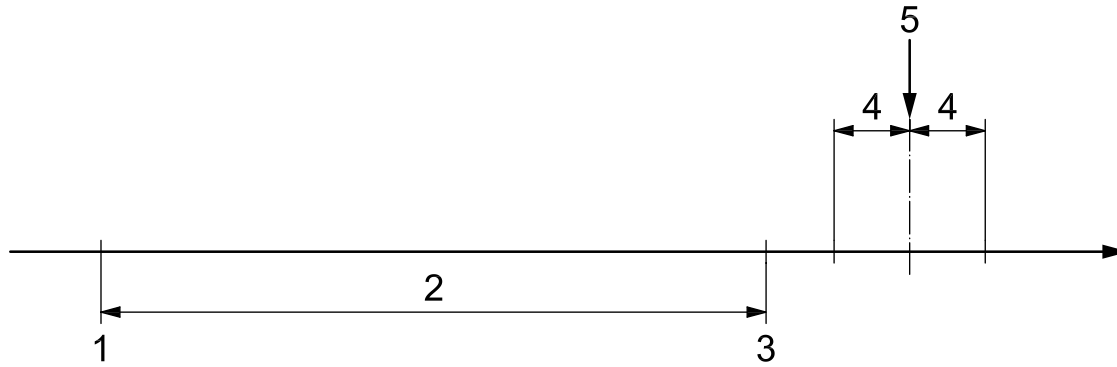

Key

- 1 lower specification limit (LSL)
- 2 specification zone
- 3 upper specification limit (USL)
- 4 uncertainty of measurement (U)
- 5 measured value

Figure A.2 — Result fail

If the test result plus/minus the uncertainty of measurement, U , overlaps a specification limit value (upper or lower) for the particular test given in the protective device standard, then the assessment of pass or fail shall be determined on the basis of safety for the wearer of the device; that is, the result shall be deemed to be a fail (see Figure A.3).

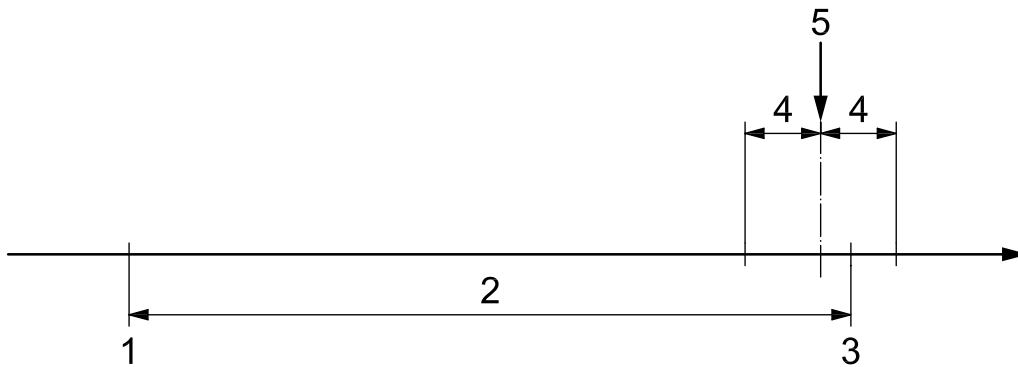

Key

- 1 lower specification limit (LSL)
- 2 specification zone
- 3 upper specification limit (USL)
- 4 uncertainty of measurement (U)
- 5 measured value

Figure A.3 — Result fail

Annex B (normative)

Fitting procedure for hoods which seal around the neck and which may or may not incorporate a head harness

B.1 Introduction

This fitting procedure was developed because, under test conditions, hoods of the type described can move in the direction of all three major axes under the influence of the cyclic pressure set up by the action of the breathing machine, thus making difficult, the provision of steady test conditions and reproducible results. In addition, the amount of exhalate that escapes via gaps at the seal around the neck can vary according to how the device is fitted on the test apparatus.

B.2 Principle

The device is fitted to a dummy head which, if necessary, is mounted on a suitable torso. The dummy head is fitted with the collar arrangement shown in Figure B.1. The neck seal of the hood is sealed to the outer circumference of the collar. The collar is sealed to the neck of the dummy and contains ports that allow air to pass out of the hood in a controlled and evenly distributed manner. By adjusting a sliding ring, more or less air is allowed out of the hood thereby controlling the pressure inside the hood to a value which approximates to that which occurs in practice on wearers. An elastic line is used to control the position of the hood on the head and the test result is determined with the hood in various positions on the dummy head.

A typical arrangement is shown in Figure B.2. If the hood is provided with a head harness then the normal fitted position shall be used. The arrangement is connected to the breathing machine and the test result is determined when stable conditions have been achieved.

B.3 Apparatus

B.3.1 Dummy head/torso, fitted with concentric tubes. The tubes are directed down the neck section to exit from the torso at a convenient point (see Figure B.2). The end of the concentric tubes is level with the top "lip" of the dummy head and the pressure probe is level with the end of the concentric tubes.

B.3.2 Vertical stand with an elastic string, for hoods which do not incorporate a head harness. One end of the string is fixed to the stand and the other to the top of the hood under test. The purpose of the elastic string is to allow movement of the hood to take place upwards and downwards and at the same time to keep the hood reasonably laterally symmetrical on the head. A light elastic string approximately 1 m in length has been found to be suitable. The stand should be of sufficient height such that when the hood is at its highest point under the action of the breathing machine, the string will clear the top of the hood and not restrain upward movement, as shown in Figure B.2.

B.3.3 Adjustable collar, a typical arrangement of which is shown in Figure B.1. The inner circumference of the upper (thicker) ring is sealed, in a leaktight manner, to the neck of the dummy head/torso. The outer circumference allows the neck seal arrangement of the hood to be fitted to it and to be suitably tightened. Thus, air allowed to pass from the hood must flow through the holes provided in both upper and lower collars and is controlled by turning the lower collar relative to the fixed upper collar.

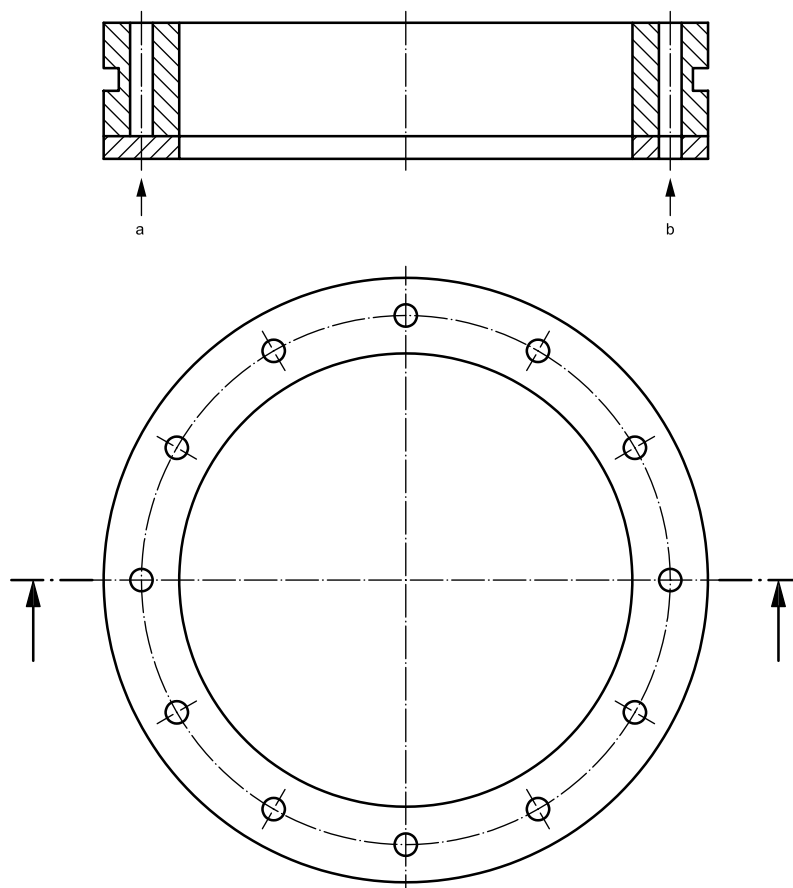

Half sections showing lower ring adjusted to give the following positions.

- a Closed.
- b Open.

Figure B.1 — Adjustable flow collar

Dimensions in millimetres

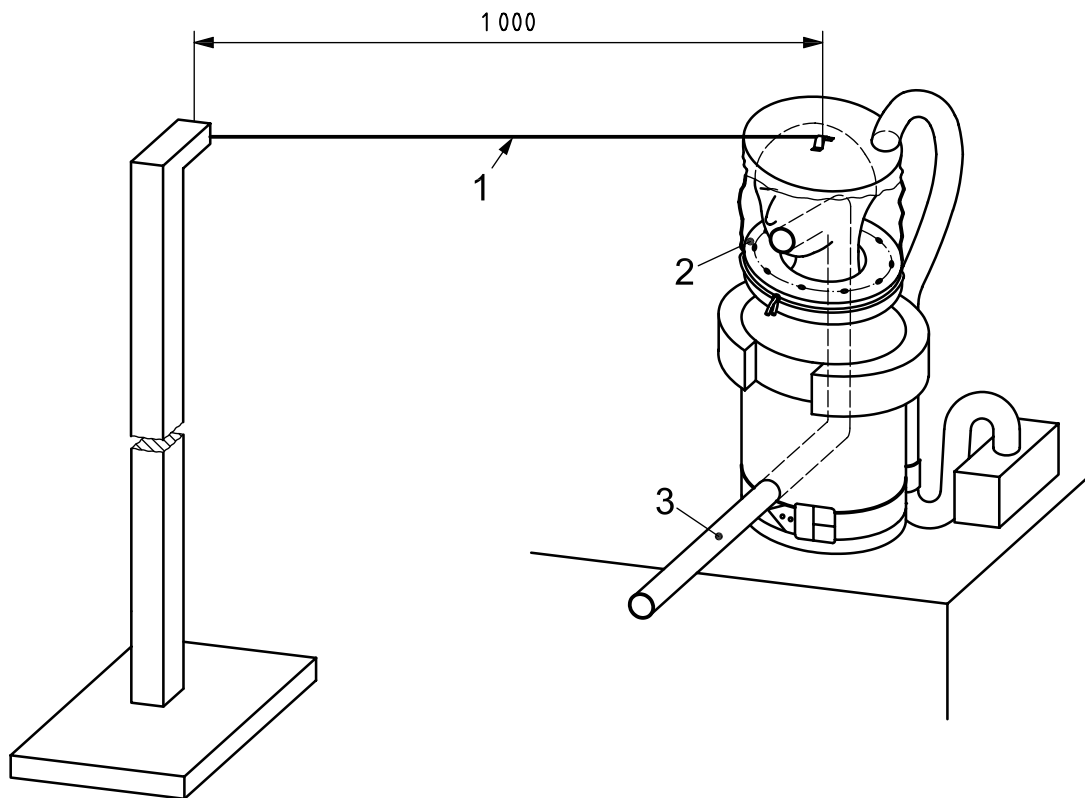
**Key**

- 1 elastic string (allows unrestricted movement of hood)
- 2 adjustable flow collar (see Figure B.1)
- 3 concentric tubes connected to breathing machine

Figure B.2 — Typical details of fitting arrangement using collar, elastic string and dummy torso

B.4 Procedure

Before performing tests involving human subjects account shall be taken of any national regulations concerning the medical history, examination or supervision of the test subjects.

A test subject dons and operates the device according to the manufacturer's instructions for use and at the maximum specified flow rate. The test subject holds their breath and the pressure within the hood is noted. The test is repeated using two further test subjects and the average value of the pressure over the minimum of three wearings is calculated and recorded.

Using the complete equipment under test, the hood is fitted over the dummy head and the drawstring of the neck seal (if fitted) is tightened around the collar or, if an elasticated neck band is fitted, it is located around the collar.

Attach the elastic string from the stand to the top of the hood noting the conditions mentioned in B.3.2.

Open the outlet port on the collar, and operate the device at the maximum flow rate. Close the outlet from the mouth of the dummy head. Gradually close the outlet from the collar until the internal pressure is equal to the average pressure noted in the above tests using subjects. Do not disturb the setting of the collar.

ISO 16900-2:2009(E)

Re-adjust the airflow to the hood to the flow rate specified by the performance standard and unseal the outlet from the mouth of the dummy head.

Connect the inlet of the concentric tubes to the breathing machine circuit and switch on the breathing machine. Adjust the height of the stand so that the top of the hood is not fouled by the elastic string at the limit of its vertical movement.

Measure and record the breathing resistance with the hood in the following three positions:

- a) just touching the nose;
- b) just touching the back of the head;
- c) central.

The position of the hood is adjusted by means of the elastic string. Throughout the duration of the test the hood shall remain as laterally symmetrical as possible about the head, and vertical movement should not be restricted.

.....

ICS 13.340.30

Price based on 14 pages