

---

---

**Air filters for general ventilation —  
Part 2:  
Measurement of fractional efficiency  
and air flow resistance**

*Filtres à air de ventilation générale —*

*Partie 2: Mesurage de l'efficacité spectrale et de la résistance à  
l'écoulement de l'air*





**COPYRIGHT PROTECTED DOCUMENT**

© ISO 2016, Published in Switzerland

All rights reserved. Unless otherwise specified, no part of this publication may be reproduced or utilized otherwise in any form or by any means, electronic or mechanical, including photocopying, or posting on the internet or an intranet, without prior written permission. Permission can be requested from either ISO at the address below or ISO's member body in the country of the requester.

ISO copyright office  
Ch. de Blandonnet 8 • CP 401  
CH-1214 Vernier, Geneva, Switzerland  
Tel. +41 22 749 01 11  
Fax +41 22 749 09 47  
copyright@iso.org  
www.iso.org

# Contents

	Page
<b>Foreword</b> .....	<b>vi</b>
<b>Introduction</b> .....	<b>vii</b>
<b>1 Scope</b> .....	<b>1</b>
<b>2 Normative references</b> .....	<b>1</b>
<b>3 Terms and definitions</b> .....	<b>2</b>
<b>4 Symbols and abbreviated terms</b> .....	<b>4</b>
4.1 Symbols.....	4
4.2 Abbreviated terms.....	6
<b>5 General test requirements</b> .....	<b>6</b>
5.1 Test device requirements.....	6
5.2 Test device installation.....	6
5.3 Test rig requirements.....	6
<b>6 Test materials</b> .....	<b>7</b>
6.1 Liquid phase aerosol.....	7
6.1.1 DEHS test aerosol.....	7
6.1.2 DEHS/DES/DOS - formula.....	7
6.1.3 DEHS properties.....	7
6.1.4 Liquid phase aerosol generation.....	7
6.2 Solid phase aerosol.....	8
6.2.1 Potassium chloride (KCl) test aerosol.....	8
6.2.2 KCl - formula.....	8
6.2.3 KCl properties.....	8
6.2.4 Solid phase aerosol generation.....	9
6.3 Reference aerosols.....	10
6.3.1 Reference aerosol for 0,3 µm to 1,0 µm.....	10
6.3.2 Reference aerosol for 1,0 µm to 10,0 µm.....	10
6.3.3 Other reference aerosols.....	10
6.3.4 Matching criteria.....	11
6.4 Aerosol loading.....	11
<b>7 Test equipment</b> .....	<b>11</b>
7.1 Test rig.....	11
7.1.1 Dimensions.....	11
7.1.2 Construction materials.....	12
7.1.3 Test rig shape.....	12
7.1.4 Test rig air supply.....	13
7.1.5 Test rig isolation.....	13
7.1.6 D/S mixing orifice.....	13
7.1.7 Aerosol sampling.....	14
7.1.8 Test rig air flow rate measurement.....	16
7.1.9 Resistance to air flow measurement.....	16
7.1.10 Non 610 mm × 610 mm (24,0 inch × 24,0 inch) test devices.....	17
7.1.11 Dust injection testing.....	18
7.2 Aerosol particle counter.....	18
7.2.1 General.....	18
7.2.2 OPC sampled size range.....	18
7.2.3 OPC particle size ranges.....	18
7.2.4 Sizing resolution.....	19
7.2.5 Calibration.....	19
7.2.6 Air flow rate.....	19
7.2.7 Zero counting.....	19
7.2.8 Dual OPC(s).....	19
7.3 Temperature, relative humidity.....	20

<b>8</b>	<b>Qualification of test rig and apparatus</b> .....	<b>20</b>
8.1	Schedule of qualification testing requirements.....	20
8.1.1	General.....	20
8.1.2	Qualification testing.....	20
8.1.3	Qualification documentation.....	20
8.2	Qualification testing.....	21
8.2.1	Test rig — Pressure system testing.....	21
8.2.2	OPC — Air flow rate stability test.....	22
8.2.3	OPC — Zero test.....	22
8.2.4	OPC — Sizing accuracy.....	23
8.2.5	OPC — Overload test.....	23
8.2.6	Aerosol generator — Response time.....	24
8.2.7	Aerosol generator — Neutralizer.....	24
8.2.8	Test rig — Air leakage test.....	25
8.2.9	Test rig — Air velocity uniformity.....	26
8.2.10	Test rig — Aerosol uniformity.....	27
8.2.11	Test rig — Downstream mixing.....	28
8.2.12	Test rig — Empty test device section pressure.....	29
8.2.13	Test rig — 100 % efficiency test and purge time.....	30
8.2.14	Test rig — Correlation ratio.....	30
8.3	Maintenance.....	30
8.3.1	General.....	30
8.3.2	Test rig — Background counts.....	31
8.3.3	Test rig — Reference filter test.....	32
8.3.4	Test rig — Pressure reference test.....	33
8.3.5	Test rig — Final filter resistance.....	33
<b>9</b>	<b>Test methods</b> .....	<b>33</b>
9.1	Air flow rate.....	33
9.2	Measurement of resistance to air flow.....	33
9.3	Measurement of fractional efficiency.....	33
9.3.1	Aerosol sampling protocol.....	33
9.3.2	Background sampling.....	33
9.3.3	Testing sequence for a single OPC.....	34
9.3.4	Testing sequence for dual OPC testing.....	36
<b>10</b>	<b>Data reduction and calculations</b> .....	<b>38</b>
10.1	Correlation ratio.....	38
10.1.1	Correlation ratio general.....	38
10.1.2	Correlation ratio data reduction.....	38
10.2	Penetration and fractional efficiency.....	40
10.2.1	Penetration and fractional efficiency general.....	40
10.2.2	Penetration data reduction.....	40
10.3	Data quality requirements.....	43
10.3.1	Correlation background counts.....	43
10.3.2	Efficiency background counts.....	43
10.3.3	Correlation ratio.....	43
10.3.4	Penetration.....	44
10.4	Fractional efficiency calculation.....	44
<b>11</b>	<b>Reporting results</b> .....	<b>45</b>
11.1	General.....	45
11.2	Required reporting elements.....	45
11.2.1	Report general.....	45
11.2.2	Report values.....	45
11.2.3	Report summary.....	45
11.2.4	Report details.....	47
	<b>Annex A (informative) Example</b> .....	<b>50</b>
	<b>Annex B (informative) Resistance to air flow calculation</b> .....	<b>57</b>

**Bibliography** ..... 59

## Foreword

ISO (the International Organization for Standardization) is a worldwide federation of national standards bodies (ISO member bodies). The work of preparing International Standards is normally carried out through ISO technical committees. Each member body interested in a subject for which a technical committee has been established has the right to be represented on that committee. International organizations, governmental and non-governmental, in liaison with ISO, also take part in the work. ISO collaborates closely with the International Electrotechnical Commission (IEC) on all matters of electrotechnical standardization.

The procedures used to develop this document and those intended for its further maintenance are described in the ISO/IEC Directives, Part 1. In particular the different approval criteria needed for the different types of ISO documents should be noted. This document was drafted in accordance with the editorial rules of the ISO/IEC Directives, Part 2 (see [www.iso.org/directives](http://www.iso.org/directives)).

Attention is drawn to the possibility that some of the elements of this document may be the subject of patent rights. ISO shall not be held responsible for identifying any or all such patent rights. Details of any patent rights identified during the development of the document will be in the Introduction and/or on the ISO list of patent declarations received (see [www.iso.org/patents](http://www.iso.org/patents)).

Any trade name used in this document is information given for the convenience of users and does not constitute an endorsement.

For an explanation on the meaning of ISO specific terms and expressions related to conformity assessment, as well as information about ISO's adherence to the World Trade Organization (WTO) principles in the Technical Barriers to Trade (TBT) see the following URL: [www.iso.org/iso/foreword.html](http://www.iso.org/iso/foreword.html).

The committee responsible for this document is ISO/TC 142, *Cleaning equipment for air and other gases*.

This first edition of ISO 16890-2, together with ISO 16890-1, ISO 16890-3 and ISO 16890-4, cancels and replaces ISO/TS 21220:2009, which has been technically revised.

ISO 16890 consists of the following parts, under the general title *Air filters for general ventilation*:

- *Part 1: Technical specifications, requirements and classification system based upon particulate matter efficiency (ePM)*
- *Part 2: Measurement of fractional efficiency and air flow resistance*
- *Part 3: Determination of the gravimetric efficiency and the air flow resistance versus the mass of test dust captured*
- *Part 4: Conditioning method to determine the minimum fractional test efficiency*

## Introduction

The effects of particulate matter (PM) on human health have been extensively studied in the past decades. The results are that fine dust can be a serious health hazard, contributing to or even causing respiratory and cardiovascular diseases. Different classes of particulate matter can be defined according to the particle size range. The most important ones are PM<sub>10</sub>, PM<sub>2,5</sub> and PM<sub>1</sub>. The U.S. Environmental Protection Agency (EPA), the World Health Organization (WHO) and the European Union define PM<sub>10</sub> as particulate matter which passes through a size-selective inlet with a 50 % efficiency cut-off at 10 µm aerodynamic diameter. PM<sub>2,5</sub> and PM<sub>1</sub> are similarly defined. However, this definition is not precise if there is no further characterization of the sampling method and the sampling inlet with a clearly defined separation curve. In Europe, the reference method for the sampling and measurement of PM<sub>10</sub> is described in EN 12341. The measurement principle is based on the collection on a filter of the PM<sub>10</sub> fraction of ambient particulate matter and the gravimetric mass determination (see EU Council Directive 1999/30/EC of 22 April 1999).

As the precise definition of PM<sub>10</sub>, PM<sub>2,5</sub> and PM<sub>1</sub> is quite complex and not simple to measure, public authorities, like the U.S. EPA or the German Federal Environmental Agency (Umweltbundesamt), increasingly use in their publications the more simple denotation of PM<sub>10</sub> as being the particle size fraction less or equal to 10 µm. Since this deviation to the above mentioned complex “official” definition does not have a significant impact on a filter element’s particle removal efficiency, the ISO 16890 series refers to this simplified definition of PM<sub>10</sub>, PM<sub>2,5</sub> and PM<sub>1</sub>.

Particulate matter in the context of the ISO 16890 series describes a size fraction of the natural aerosol (liquid and solid particles) suspended in ambient air. The symbol  $ePM_x$  describes the efficiency of an air cleaning device to particles with an optical diameter between 0,3 µm and  $x$  µm. The following particle size ranges are used in the ISO 16890 series for the listed efficiency values.

**Table 1 — Optical particle diameter size ranges for the definition of the efficiencies,  $ePM_x$**

Efficiency	Size range, µm
$ePM_{10}$	$0,3 \leq x \leq 10$
$ePM_{2,5}$	$0,3 \leq x \leq 2,5$
$ePM_1$	$0,3 \leq x \leq 1$

Air filters for general ventilation are widely used in heating, ventilation and air-conditioning applications of buildings. In this application, air filters significantly influence the indoor air quality and, hence, the health of people, by reducing the concentration of particulate matter. To enable design engineers and maintenance personnel to choose the correct filter types, there is an interest from international trade and manufacturing for a well-defined, common method of testing and classifying air filters according to their particle efficiencies, especially with respect to the removal of particulate matter. Current regional standards are applying totally different testing and classification methods which do not allow any comparison with each other, and thus hinder global trade with common products. Additionally, the current industry standards have known limitations by generating results which often are far away from filter performance in service, i.e. overstating the particle removal efficiency of many products. With this new ISO 16890 series, a completely new approach for a classification system is adopted, which gives better and more meaningful results compared to the existing standards.

The ISO 16890 series describes the equipment, materials, technical specifications, requirements, qualifications and procedures to produce the laboratory performance data and efficiency classification based upon the measured fractional efficiency converted into a particulate matter efficiency ( $ePM$ ) reporting system.

Air filter elements according to the ISO 16890 series are evaluated in the laboratory by their ability to remove aerosol particulate expressed as the efficiency values  $ePM_1$ ,  $ePM_{2,5}$  and  $ePM_{10}$ . The air filter elements can then be classified according to the procedures defined in ISO 16890-1. The particulate removal efficiency of the filter element is measured as a function of the particle size in the range of 0,3 µm to 10 µm of the unloaded and unconditioned filter element as per the procedures defined in this part of ISO 16890. After the initial particulate removal efficiency testing, the air filter element is

## ISO 16890-2:2016(E)

conditioned according to the procedures defined in ISO 16890-4 and the particulate removal efficiency is repeated on the conditioned filter element. This is done to provide information about the intensity of any electrostatic removal mechanism which may or may not be present with the filter element for test. The average efficiency of the filter is determined by calculating the mean between the initial efficiency and the conditioned efficiency for each size range. The average efficiency is used to calculate the  $ePM_x$  efficiencies by weighting these values to the standardized and normalized particle size distribution of the related ambient aerosol fraction. When comparing filters tested in accordance with the ISO 16890 series, the fractional efficiency values shall always be compared among the same  $ePM_x$  class (ex.  $ePM_1$  of filter A with  $ePM_1$  of filter B). The test dust capacity and the initial arrestance of a filter element are determined as per the test procedures defined in ISO 16890-3.



# Air filters for general ventilation —

## Part 2: Measurement of fractional efficiency and air flow resistance

### 1 Scope

This part of ISO 16890 specifies the aerosol production, the test equipment and the test methods used for measuring fractional efficiency and air flow resistance of air filters for general ventilation.

It is intended for use in conjunction with ISO 16890-1, ISO 16890-3 and ISO 16890-4.

The test method described in this part of ISO 16890 is applicable for air flow rates between 0,25 m<sup>3</sup>/s (900 m<sup>3</sup>/h, 530 ft<sup>3</sup>/min) and 1,5 m<sup>3</sup>/s (5 400 m<sup>3</sup>/h, 3 178 ft<sup>3</sup>/min), referring to a test rig with a nominal face area of 610 mm × 610 mm (24,0 inch × 24,0 inch).

ISO 16890 (all parts) refers to particulate air filter elements for general ventilation having an *ePM*<sub>1</sub> efficiency less than or equal to 99 % and an *ePM*<sub>10</sub> efficiency greater than 20 % when tested as per the procedures defined within ISO 16890 (all parts).

**NOTE** The lower limit for this test procedure is set at a minimum *ePM*<sub>10</sub> efficiency of 20 % since it will be very difficult for a test filter element below this level to meet the statistical validity requirements of this procedure.

Air filter elements outside of this aerosol fraction are evaluated by other applicable test methods, (see ISO 29463 (all parts)).

Filter elements used in portable room-air cleaners are excluded from the scope.

The performance results obtained in accordance with ISO 16890 (all parts) cannot by themselves be quantitatively applied to predict performance in service with regard to efficiency and lifetime.

### 2 Normative references

The following documents, in whole or in part, are normatively referenced in this document and are indispensable for its application. For dated references, only the edition cited applies. For undated references, the latest edition of the referenced document (including any amendments) applies.

ISO 16890-1, *Air filters for general ventilation — Part 1: Technical specifications, requirements and efficiency classification system based upon Particulate Matter (PM)*

ISO 16890-3, *Air filters for general ventilation — Part 3: Determination of the gravimetric efficiency and the air flow resistance versus the mass of test dust captured*

ISO 16890-4, *Air filters for general ventilation — Part 4: Conditioning method to determine the minimum fractional test efficiency*

ISO 5167-1, *Measurement of fluid flow by means of pressure differential devices inserted in circular cross-section conduits running full — Part 1: General principles and requirements*

ISO 21501-1, *Determination of particle size distribution — Single particle light interaction methods — Part 1: Light scattering aerosol spectrometer*

ISO 21501-4, *Determination of particle size distribution — Single particle light-interaction methods — Part 4: Light scattering airborne particle counter for clean spaces*

## ISO 16890-2:2016(E)

ISO 29463, *High-efficiency filters and filter media for removing particles in air*

ISO 29464:2011, *Cleaning equipment for air and other gases — Terminology*

### 3 Terms and definitions

For the purposes of this document, the terms and definitions given in ISO 29464 and the following apply.

#### 3.1 Air flow and resistance

##### 3.1.1

##### **air flow rate**

volume of air passing through the filter per unit time

[SOURCE: ISO 29464:2011, 3.2.38]

##### 3.1.2

##### **nominal air flow rate**

*air flow rate* (3.1.1) specified by the manufacturer

##### 3.1.3

##### **resistance to airflow**

difference in pressure between two points in an airflow system at specified conditions, especially when measured across the *filter element* (3.2.2)

#### 3.2 Test device

##### 3.2.1

##### **test device**

*filter element* (3.2.2) to be tested

##### 3.2.2

##### **filter element**

structure made of the filtering material, its supports and its interfaces with the filter housing

##### 3.2.3

##### **upstream**

U/S

region in a process system traversed by a flowing fluid before it enters that part of the *test device* (3.2.1)

##### 3.2.4

##### **downstream**

D/S

area or region into which fluid flows on leaving the *test device* (3.2.1)

#### 3.3 Aerosol

##### 3.3.1

##### **liquid phase aerosol**

liquid particles suspended in a gas

##### 3.3.2

##### **solid phase aerosol**

solid particles suspended in a gas

##### 3.3.3

##### **reference aerosol**

defined approved aerosol for test measurement within a specific size range

**3.3.4****neutralization**

action of bringing the aerosol to a Boltzmann charge equilibrium distribution with bipolar ions

**3.4 Particle counter****3.4.1****particle counter**

device for detecting and counting numbers of discrete airborne particles present in a sample of air

[SOURCE: ISO 29464:2011, 3.1.27]

**3.4.2****optical particle counter****OPC**

*particle counter* ([3.4.1](#)) which functions by illuminating airborne particles in a sample flow of air, converting the scattered light impulses to electrical impulse data capable of analysis to provide data on particle population and size distribution

[SOURCE: ISO 29464:2011, 3.29]

**3.4.3****sampling air flow**

volumetric flow rate through the instrument

**3.4.4****particle size**

*ps*

geometric diameter (equivalent spherical, optical or aerodynamic, depending on context) of the particles of an aerosol

[SOURCE: ISO 29464:2011, 3.1.126]

**3.4.5****particle size distribution**

presentation, in the form of tables, numbers or graphs, of the experimental results obtained using a method or an apparatus capable of measuring the equivalent diameter of particles in a sample or capable of giving the proportion of particles for which the equivalent diameter lies between defined limits

[SOURCE: ISO 29464:2011, 3.1.128]

**3.4.6****isokinetic sampling**

technique for air sampling such that the probe inlet air velocity is the same as the velocity of the air surrounding the sampling point

[SOURCE: ISO 29464:2011, 3.1.144]

**3.5 Efficiency****3.5.1****efficiency**

fraction or percentage of a challenge contaminant that is removed by a *test device* ([3.2.1](#))

**3.5.2****fractional efficiency**

ability of an air cleaning device to remove particles of a specific size or size range

Note 1 to entry: The efficiency plotted as a function of particle size gives the particle size efficiency spectrum.

[SOURCE: ISO 29464:2011, 3.1.61]

## ISO 16890-2:2016(E)

### 3.5.3

#### penetration

$P$

ratio of particle count detected downstream versus the particle count upstream

[SOURCE: ISO 29464:2011, 3.1.130]

### 3.5.4

#### correlation ratio

$R$

calculation of any potential bias between the upstream and downstream sampling systems

## 3.6 Other terms

### 3.6.1

#### HEPA filter

filters with performance complying with requirements of filter class ISO 35 to ISO 45 as per ISO 29463-1

[SOURCE: ISO 29464:2011, 3.1.88]

### 3.6.2

#### reference filter

primary device possessing accurately known parameters used as a standard for calibrating secondary devices

[SOURCE: ISO 29464:2011, 3.39]

## 4 Symbols and abbreviated terms

### 4.1 Symbols

DEHS	(DiEthylHexylSebacate)
KCl	potassium chloride solid phase aerosol
$Ra$	current radioactivity of the source
$Ra_0$	radioactivity of the source at date of manufacturer
$t$	time (years)
$t_{0,5}$	half-life time (years)
$CV$	coefficient of variation
$\delta$	standard deviation of the data points
<i>mean</i>	mean value of the data points
$U_{c,i,ps}$	upstream correlation count for sample $i$ , and particle size, $ps$
$D_{c,i,ps}$	downstream correlation count for sample $i$ , and particle size, $ps$
$U_{B,b,ps}, U_{B,f,ps}$	upstream beginning or final background average count at a specific particle size, $ps$
$D_{B,b,ps}, D_{B,f,ps}$	downstream beginning or final background average count at a specific particle size, $ps$
$D_{B,ps}$	downstream background average count for efficiency sample, $i$ , and for particle size, $ps$

$D_{B,c,ps}$	downstream background average count for correlation sample, $i$ , and for particle size, $ps$
$B_{b,i,ps}, B_{f,i,ps}$	measured beginning or final upstream background count for sample, $i$ , and particle size, $ps$
$d_{b,ps}, d_{f,ps}$	measured beginning or final downstream background count for particle size, $ps$
$U_{B,ps}, U_{B,c,ps}$	upstream background average count for efficiency or correlation at a specific particle size, $ps$
$N_{i,ps}$	measured upstream efficiency count for sample, $i$ , and particle size, $ps$
$U_{i,ps}$	upstream efficiency average for sample, $i$ , and for particle size, $ps$
$U_{tot,ps}$	sum of the upstream particle counts for particle size, $ps$
$D_{i,ps}$	downstream efficiency average for sample, $i$ , and for particle size, $ps$
$R_{i,ps}$	correlation ratio for sample, $i$ , and for particle size, $ps$
$\bar{R}_{ps}$	correlation ratio at a specific particle size, $ps$
$n$	number of samples
$e_{c,ps}$	95 % uncertainty of the correlation value at a specific particle size, $ps$
$st$	student's $t$ distribution variable
$v$	number of degrees of freedom for student's $t$ distribution variable
$\bar{R}_{lcl,ps}$	lower confidence limit of the correlation ratio at a specific particle size, $ps$
$\bar{R}_{ucl,ps}$	upper confidence limit of the correlation ratio at a specific particle size, $ps$
$\delta_{c,ps}$	standard deviation of the correlation value at a specific particle size, $ps$
$U_{c,tot,ps}$	sum of the upstream particles sampled during correlation at a specific particle size, $ps$
$U_{c,i,ps}$	correlation particles sampled for sample, $i$ , and for particle size, $ps$
$P$	penetration or the fraction of particulate that penetrates the test device
$\bar{P}_{o,ps}$	observed penetration at a specific particle size, $ps$
$\bar{P}_{ps}$	final penetration at a specific particle size, $ps$
$\bar{P}_{lcl,ps}$	lower confidence limit of the penetration at a specific particle size, $ps$
$\bar{P}_{ucl,ps}$	upper confidence limit of the penetration at a specific particle size, $ps$
$e_{ps}$	95 % uncertainty of the penetration value at a specific particle size, $ps$
$\delta_{ps}$	standard deviation of the penetration value at a specific particle size, $ps$
$e_i$	static or dynamic uncertainty
$U_{tot,ps}$	sum of the upstream particles sampled during penetration at a specific particle size, $ps$
$E_{ps}$	fractional efficiency at a specific particle size, $ps$

## **4.2 Abbreviated terms**

ASHRAE	American Society of Heating Refrigeration and Air Conditioning Engineers
CEN	European Committee for Standardization
CL	concentration limit
NIST	National Institute of Standards and Technology
PSL	polystyrene latex spheres
RH	relative humidity, %
TR	test rig

## **5 General test requirements**

### **5.1 Test device requirements**

The test device shall be designed so that when correctly mounted in the ventilation test rig, no air/dust leaks occur around the exterior test device frame and the test rig sealing surfaces. The test device shall be designed or marked so as to prevent incorrect mounting.

The complete test device (filter and frame) shall be made of material suitable to withstand normal usage and exposure to the range of temperature, humidity and corrosive environments likely to be encountered in service.

The complete test device shall be designed so that it will withstand mechanical constraints that are likely to be encountered during normal use. Dust or fibre released from the test device media by air flow through the test device shall not constitute a hazard or nuisance for the people (or devices) exposed to filtered air.

### **5.2 Test device installation**

The test device shall be mounted in accordance with the manufacturer's recommendations and after environmental equilibrium with the test air weighed to the nearest gram. Devices requiring external accessories shall be operated during the test with accessories having characteristics equivalent to those used in actual practice. The test device, including any normal mounting frame, shall be sealed into the test rig in a manner that prevents leakage. The tightness shall be checked by visual inspection and no visible leaks are acceptable. If for any reason dimensions do not allow testing of a test device under standard test conditions, assembly of two or more devices of the same type or model is permitted, provided no leaks occur in the resulting assembly. The operating conditions of such accessory equipment shall be recorded.

### **5.3 Test rig requirements**

Critical dimensions and arrangements of the test apparatus are shown in the figures of this part of ISO 16890 and are intended as guides to help construct a test rig to meet the performance requirements of this part of ISO 16890. All dimensions shown are mandatory unless otherwise indicated. Tolerances are shown in the figures herein. Units are in mm (inch) unless otherwise indicated. The design of equipment not specified (including, but not limited to, blowers, valves and external piping) is discretionary, but the equipment shall have adequate capacity to meet the performance requirements of this part of ISO 16890.

## 6 Test materials

### 6.1 Liquid phase aerosol

#### 6.1.1 DEHS test aerosol

Liquid phase aerosol of DEHS (DiEthylHexylSebacate) produced by a Laskin nozzle arrangement is widely used in the testing of high efficiency filters. DEHS is the same as DES Di (2-ethylhexyl) Sebacate or Bis (2-ethylhexyl) Sebacate since the aerodynamic, geometric and light scattering sizes are close to each other when measured with optical particle counters (OPC). The DEHS aerosol shall be used untreated and introduced directly into the test rig.

#### 6.1.2 DEHS/DES/DOS - formula

$C_{26}H_{50}O_4$  or  $CH_3(CH_2)_3CH(C_2H_5)CH_2OOC(CH_2)_8COOCH_2CH(C_2H_5)(CH_2)_3CH_3$

#### 6.1.3 DEHS properties

Molecular weight	426,69 g/mol
Density	912 kg/m <sup>3</sup> (57 lb/ft <sup>3</sup> )
Melting point	225 K
Boiling point	505 K to 522 K
Flash point	>473 K
Vapour pressure	<1 Pa at 293 K
Refractive index	1,452 at 600 nm wavelength
Dynamic viscosity	0,022 Pa·s (0,015 lb/ft·s) to 0,024 Pa·s (0,016 lb/ft·s)
CAS number	122-62-3

#### 6.1.4 Liquid phase aerosol generation

The test aerosol shall consist of untreated and undiluted DEHS, or other liquid phase aerosols in accordance with [6.3](#) aerosol reference.

[Figure 1](#) gives an example of a system for generating the aerosol. It consists of a small container with DEHS liquid and a Laskin nozzle. The aerosol is generated by feeding compressed particle-free air through the Laskin nozzle. The atomized droplets are then directly introduced into the test rig. The pressure and air flow to the nozzle are varied according to the test flow and the required aerosol concentration.

NOTE For a test air flow rate of 0,944 m<sup>3</sup>/s (2 000 ft<sup>3</sup>/min), the pressure is about 17 kPa (2,5 lb/in<sup>2</sup>), corresponding to an air flow of about 0,39 dm<sup>3</sup>/s [1,4 m<sup>3</sup>/h, (0,82 ft<sup>3</sup>/min)] through the nozzle.

Any other generator capable of producing droplets in sufficient concentrations in the particle size range of 0,3 µm to 1,0 µm can be used.

Before testing, regulate the upstream concentration to reach steady-state and to have a concentration below the coincidence level of the OPC.

Dimensions in millimetres

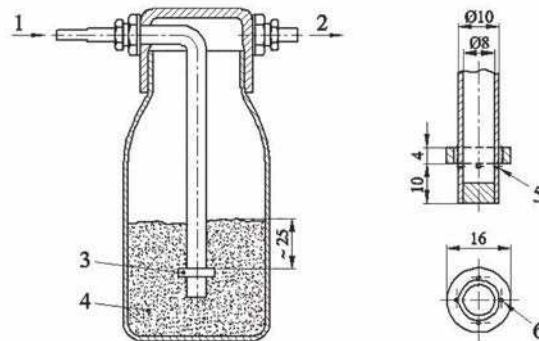

**Key**

- 1 particle-free air (pressure about 17 kPa) (2,5 lb/in<sup>2</sup>)
- 2 aerosol to test rig
- 3 laskin nozzle
- 4 liquid test aerosol
- 5 four  $\varnothing$  1,0 mm holes 90° apart top edge of holes and just touching the bottom of the collar
- 6 four  $\varnothing$  2,0 mm holes next to tube in line with the  $\varnothing$  1,0 mm holes (key 5)

**Figure 1 — Liquid phase aerosol generator**

**6.2 Solid phase aerosol**

**6.2.1 Potassium chloride (KCl) test aerosol**

The KCl test aerosol shall be polydisperse solid-phase (dry) potassium chloride (KCl) particles generated from an aqueous solution. For example, a KCl solution can be prepared by combining 120 g of reagent grade KCl with 1 l of reagent grade distilled water. The solution is fed to the atomizing nozzle at around 1,2 ml/min (0,04 oz/min) by a metering pump. Varying the operating air pressure of the generator and the solution flow rate allows control of the challenge aerosol concentration.

NOTE 1 Reagent grade water as defined by ASTM D1193.

NOTE 2 The 120 g KCl to 1 l of water shown here is an example. The actual ratio used may vary depending on the equipment used.

**6.2.2 KCl - formula**

KCl

**6.2.3 KCl properties**

Molecular weight	74,55 g/mol
Density	1 984 kg/m <sup>3</sup> (123,86 lb/ft <sup>3</sup> )
Melting point	1 049 K
Boiling Point	1 686 K



Solubility	347 kg/m <sup>3</sup> at 293 K
Refractive index	1,490 at 600 nm wavelength
CAS number	7447-40-7

#### 6.2.4 Solid phase aerosol generation

The solid phase test aerosol generator shall be as illustrated in [Figure 2](#). The aerosol generator shall provide a stable test aerosol of sufficient concentration over the 0,30 µm to 10 µm particle size range to meet the minimum aerosol requirements of this part of ISO 16890 without overloading the OPC.

The nozzle is positioned at the top of a 305 mm (12,0 inch) diameter, 1 300 mm (51,0 inch) high transparent acrylic spray tower. The tall tower serves two purposes: it allows the KCl droplets to dry by providing an approximately 40 s mean residence time and it allows larger-sized particles to fall out of the aerosol.

The aerosol shall be brought to a Boltzmann electrostatic charge distribution by an alpha or beta radiation generator with an activity of at least 185 MBq (5 mCi) or a corona discharge ionizer. The corona discharge ionizer shall have a minimum corona current of 3 µA and shall be balanced to provide equal amounts of positive and negative ions.

NOTE 1 A Boltzmann charge distribution is the average charge found in ambient air. Electrostatic charging is an unavoidable consequence of most aerosol generation methods of a solid phase aerosol.

NOTE 2 The activity level of a radioactive source decreases with time. The source strength of 185 MBq (5 mCi) is the minimum source strength at the end of the life. Thus, if the source strength is 370 MBq (10 mCi) when new, the source strength will be 185 MBq (5 mCi) after one half-life of decay.

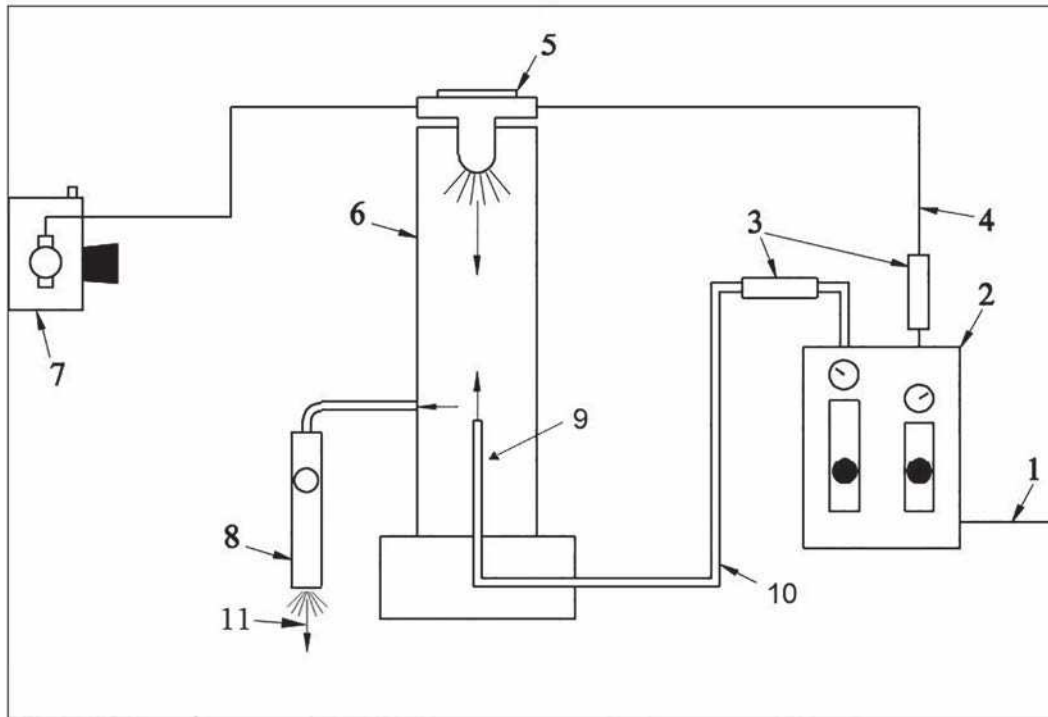

**Key**

- 1 clean, dry compressed air source
- 2 air control panel (rotameters with needle valve and outlet pressure gauge)
- 3 minimum HEPA efficiency filters
- 4 atomizing air 0,5 dm<sup>3</sup>/s (1 ft<sup>3</sup>/min) nominal (adjusted speed)
- 5 air atomizing nozzle
- 6 spray tower 305 mm (12,0 inch) diam. 1 300 mm (51,0 inch) tall
- 7 metering pump speed 20 cm/s, KCl solution water
- 8 radioactive neutralizer located at aerosol outlet, if used
- 9 corona discharge neutralizer located in drying air supply line, if used
- 10 drying air 1,9 dm<sup>3</sup>/s (0,040 ft<sup>3</sup>/min)
- 11 outlet tube 38 mm (1,5 inch) internal diameter (can be located on the bottom of the spray tower)

**Figure 2 — Schematic diagram of the solid phase aerosol particle generator system**

**6.3 Reference aerosols**

**6.3.1 Reference aerosol for 0,3 µm to 1,0 µm**

For measuring the filtration performance from 0,3 µm to 1,0 µm, the liquid phase aerosol listed in [6.1](#) shall be the reference material for this test method.

**6.3.2 Reference aerosol for 1,0 µm to 10,0 µm**

For measuring the filtration performance from 1,0 µm to 10,0 µm, the solid phase aerosol listed in [6.2](#) shall be the reference material for this test method.

**6.3.3 Other reference aerosols**

Only aerosols listed in [6.1](#) and [6.2](#) may be used to test devices as per this part of ISO 16890. In order to use an aerosol outside of the reference range for that aerosol, acceptable matching to the results of the

reference aerosol for the particle size range being measured shall be achieved according to [6.3.4](#). Liquid phase aerosol can only be used to measure filtration performance in the particle size range from 1,0 µm to 10,0 µm if the test device media velocity is below 20 cm/s (39,4 ft/min).

#### **6.3.4 Matching criteria**

To show an acceptable aerosol matching, a reference test filter, as defined in [8.3.2](#), shall be run using the reference aerosol and repeated using the trial aerosol. If the filtration efficiency results are within two percentage points in each measured channel, the trial aerosol can be used in that particle size range. A written report showing evidence of this matching shall be maintained at the testing facility. This test shall be repeated as part of any test rig qualification testing and maintenance testing from [8.3.3](#).

### **6.4 Aerosol loading**

Any aerosol used to test the filtration performance according to this part of ISO 16890 shall be introduced in the filter element long enough to allow the test to be performed, but not so long as to change the filtration performance characteristics of the tested device.

## **7 Test equipment**

### **7.1 Test rig**

#### **7.1.1 Dimensions**

##### **7.1.1.1 Cross dimensional area**

The test rig (see [Figure 3](#)) consists of several square segments with 610 mm × 610 mm (24 inch × 24 inch) nominal inner dimensions except for the test device section. The test device is located in section C and may have nominal inner dimensions between 610 mm (24,0 inch) and 622 mm (24,5 inch).

##### **7.1.1.2 Length and location dimensions**

The minimum or required dimensions for test rig (TR) section lengths and equipment locations are shown in [Figure 3](#).

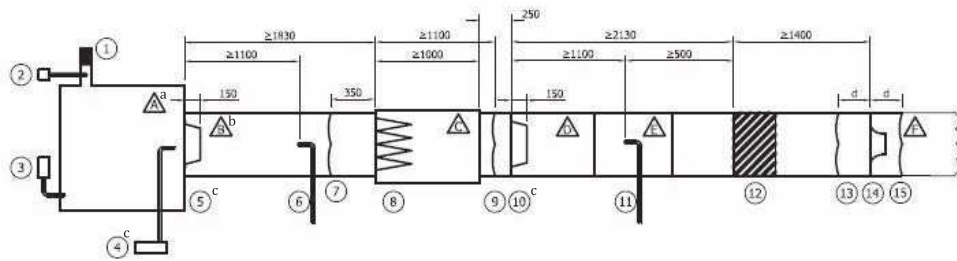

**Key**

- |   |                                      |    |  |
|---|--------------------------------------|----|--|
| A | TR section — U/S inlet plenum        | 9  | D/S test device pressure tap   |
| B | TR section — U/S Sampling            | 10 | D/S mixing orifice (efficiency testing)<br>If dust loading, D/S final filter   |
| C | TR section — Test device             | 11 | D/S aerosol sampling head  |
| D | TR section — D/S Mixing/Final Filter | 12 | D/S HEPA filtration (if used)  |
| E | TR section — D/S Sampling            | 13 | example of upper air flow nozzle pressure tap (if used)  |
| F | TR section — Air flow measurement    | 14 | example of air flow measurement device location  |
| 1 | U/S HEPA filtration                  | 15 | example of lower air flow nozzle pressure tap (if used)  |
| 2 | liquid aerosol injection             | a  | U/S denotes upstream of the test device.   |
| 3 | solid aerosol injection              | b  | D/S denotes downstream of the test device.   |
| 4 | dust injection nozzle                | c  | Devices used only with dust load testing.  |
| 5 | U/S mixing orifice                   | d  | Air flow nozzle pressure taps shall be located according to the device manufacturer’s installation specification requirements. |
| 6 | U/S aerosol sampling head            |    |  |
| 7 | U/S test device pressure tap         |    |  |
| 8 | test device                          |    |  |

**Figure 3 — Schematic diagram of the test rig**

**7.1.2 Construction materials**

The test rig material shall be electrically conductive, electrically grounded, shall have a smooth interior finish, and be sufficiently rigid to maintain its shape at the operating pressure. Smaller parts of the test rig could be made in glass or plastic to see the test device and equipment. Provision of windows to allow monitoring of test progress is acceptable.

**7.1.3 Test rig shape**

The entry plenum and the relative location of high efficiency filters and aerosol injections are discretionary and a bend in the test rig is optional, thereby allowing both a straight test rig and a U-shaped test rig configuration. Except for the bend itself, all dimensions and components are the same for the straight and U-shaped configurations. A downstream mixing baffle shall be included in the test rig after the bend. The length of the test rig and individual sections are discretionary, but the test rig shall meet all of the apparatus qualification tests described in [Clause 8](#).

## 7.1.4 Test rig air supply

### 7.1.4.1 Fan location

The test rig can be operated either in a negative or positive pressure air flow arrangement.

NOTE In the case of positive pressure operation (i.e. the fan upstream of the U/S HEPA), the test aerosol and loading dust could leak into the room, while at negative pressure (i.e. the fan downstream of the D/S HEPA) particles could leak into the test rig.

### 7.1.4.2 Environment

Room air or recirculated air shall be used as the test air source. The temperature of the air at the test device shall be  $(23 \pm 5) ^\circ\text{C}$  [ $(73 \pm 9) ^\circ\text{F}$ ] with a relative humidity of  $(45 \pm 10) \%$ . Exhaust flow can be discharged outdoors, indoors, or recirculated.

NOTE The relative humidity can affect results when counting particles of solid phase aerosol, as shown in ASHRAE 1287-RP. The narrow relative humidity range is a result of that work.

### 7.1.4.3 Test rig HEPA filtration

High efficiency HEPA filters shall be placed in the test rig airstream upstream of the test rig section A. The purpose of this upstream filtration is to provide very low background particulate levels during a test.

HEPA filtration of the exhaust flow is recommended, but not required. An exhaust HEPA filter allows for the removal of any test aerosol that may be present in the exhaust air. If the exhaust HEPA is used, it shall be a minimum of 500 mm (20 inch) from the downstream sampling head.

## 7.1.5 Test rig isolation

The test rig shall be isolated from vibration caused by the blower or other sources of vibration.

## 7.1.6 D/S mixing orifice

For all fractional efficiency measurements, the D/S mixing orifice shall be installed as shown in [Figure 3](#), downstream of the test device and upstream of the D/S sample head. The mixing orifice is made up of an orifice plate (1) and a perforated plate as the mixing baffle (2), as shown in [Figure 4](#).

The mixing baffle shall be  $152 \text{ mm} \pm 2 \text{ mm}$  ( $5,9 \text{ inch} \pm 0,8 \text{ inch}$ ) in diameter and have equally sized and spaced holes with lines in a staggered pattern to provide a 40 % open area and mounted so the centre line is in line with the centre of the hole in the mixing orifice. The pattern of the holes shall be as close as possible to 3,175 mm (0,125 inch) diameter holes on 4,76 mm (0,187 5 inch) centres.

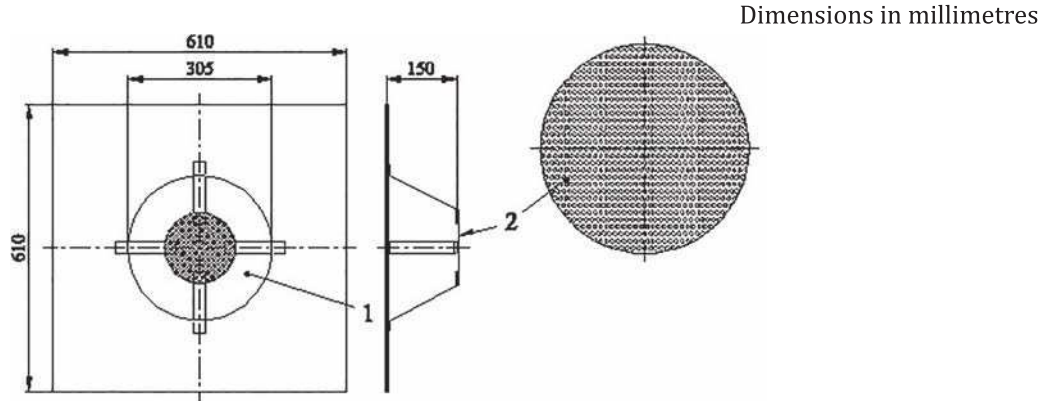

**Key**

- 1 orifice plate
- 2 perforated plate, equally space holes, 40 % open area, staggered lines

**Figure 4 — Mixing orifice**

**7.1.7 Aerosol sampling**

**7.1.7.1 Sample lines**

The upstream and downstream sample lines (both primary and secondary, if used) shall be made of rigid electrically conductive and electrically grounded metallic tubing having a smooth inside surface, and shall be rigidly secured to prevent movement during testing. The upstream and downstream sample lines shall be nominally identical in geometry (bends and straight lengths). The portion of the sampling lines inside the test rig shall block less than 10 % of the test rig cross-sectional area. The use of a short length [50 mm (2,0 inch) maximum] of straight, flexible, electrically dissipative tubing to make the final connection to the OPC is acceptable.

NOTE 1 Particle losses in the test rig, aerosol transport lines and OPC need to be minimized because a smaller number of counted particles will mean larger statistical errors and less accurate results. The influence of particle losses on the result is minimized if the upstream and downstream sampling losses are made as near equal as possible.

NOTE 2 The use of a short flexible connection often relieves stress that would be placed on the instrument's inlet.

**7.1.7.2 Sample probes**

Tapered sharp-edged sampling probes are placed in the centre of the upstream and downstream measuring sections. The sampling heads shall be centrally located on the line with the inlet tip facing the inlet of the test rig parallel to the air flow. The sampling probe tip diameter shall be sized to provide isokinetic sampling within 10 % in the test rig for a test air flow rate of 0,944 m<sup>3</sup>/s (2 000 ft<sup>3</sup>/min). Changing sampling probe tip diameters to maintain isokinetic sampling in the test rig at other test air flow rates is recommended. The probe diameter shall be a minimum of 6 mm (0,25 inch).

NOTE This refers to the average air velocity in the test rig and not to the local velocity dependent on the velocity pattern.

**7.1.7.3 Sampling air flow**

If the OPC has an air flow pump and the air flow can be maintained by the pump sufficient to provide isokinetic sampling while meeting the requirements of [7.1.7.2](#), then the OPC pump can provide the

sample air flow rate. The upstream and downstream sample air flow rate shall each be <2 % of the test rig air flow rate.

#### 7.1.7.4 Secondary sampling

The use of a primary and secondary sampling system is allowed to optimize particle transport from the inlet probe to the OPC with the following conditions.

- a) Air flow rate through the primary sampling system shall be measured to within 5 % with volumetric devices.
- b) Isokinetic sampling to within 10 % shall be maintained on both primary and secondary probes.
- c) The upstream and downstream secondary sampling systems shall be of equal length and equivalent geometry.
- d) The upstream and downstream primary sample air flow rates shall each be <2 % of the system air flow rate.

NOTE The primary lines (one from the upstream location, one from the downstream location) draw the samples from the test rig and transport them to the vicinity of the OPC(s). The primary system uses an auxiliary pump and flow metering system to operate at a higher air flow rate than would be provided by the OPC(s) alone. The higher air flow rate combined with larger diameter sampling lines improves particle transport. The OPC(s) then draws a lower flow rate sample from the primary line. The sample lines from the OPC(s) to the primary sample lines are termed the secondary sample lines.

- e) The auxiliary pump and associated flow control and flow measurement devices of the primary sampling lines shall be downstream of secondary probes.

#### 7.1.7.5 Aerosol diluters

If an aerosol concentration in the test rig exceeds the limits of the particle counting system, no test can be run as per this part of ISO 16890. An aerosol dilution system (diluter) may not be used to lower this concentration due to the uneven particle dilution of larger particulate by the dilution system.

#### 7.1.7.6 Valve requirements

Three one-way valves (see [Figure 5](#)) make it possible to sample the aerosol upstream or downstream of the test device under test, or to have a “blank” suction through a HEPA filter. If used, the valves shall be of a straight-through design to minimize impaction or other losses in the valve. Due to possible particle losses from the sampling system, the first measurement after a valve is switched should be ignored.

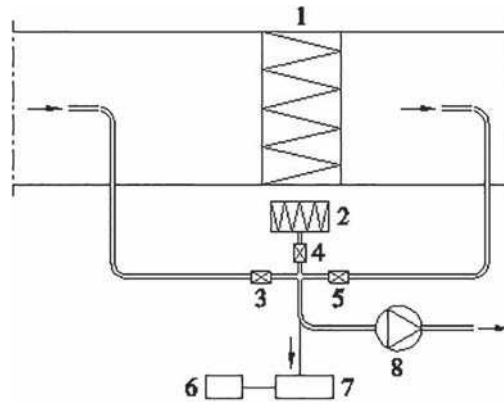

- Key**
- 1 test device
  - 2 HEPA filter (clean air)
  - 3 valve, upstream
  - 4 valve, clean air
  - 5 valve, downstream
  - 6 computer
  - 7 OPC
  - 8 pump

**Figure 5 — Schematic diagram of the aerosol sampling system**

**7.1.8 Test rig air flow rate measurement**

Flow measurement shall be made by standardized flow measuring devices in accordance with ISO 5167-1. The uncertainty of measurement shall not exceed 5 % of the measured value.

**7.1.9 Resistance to air flow measurement**

Measurements of resistance to air flow shall be taken between measuring points located in the test rig wall as shown in [Figure 3](#). Each measuring point shall comprise four interconnected static pressure taps (see [Figure 6](#)) equally distributed around the periphery of the test rig cross section. [Figure 6](#) is shown as an example of a static pressure tap. The static pressure tap hole shall be 2 mm ± 0,5 mm (0,08 inch ± 0,02 inch). The complete system should pass the qualification testing in [8.2](#).

The pressure measuring equipment used shall be capable of measuring pressure differences with an accuracy of ±2 Pa (0,01 inch H<sub>2</sub>O) in the range of 0 Pa to 70 Pa (0,28 inch H<sub>2</sub>O). Above 70 Pa (0,28 inch H<sub>2</sub>O), the accuracy shall be ±3 % of the measured value.



Dimensions in millimetres

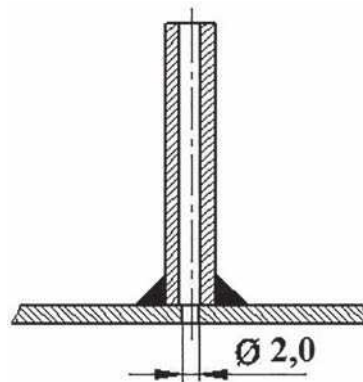
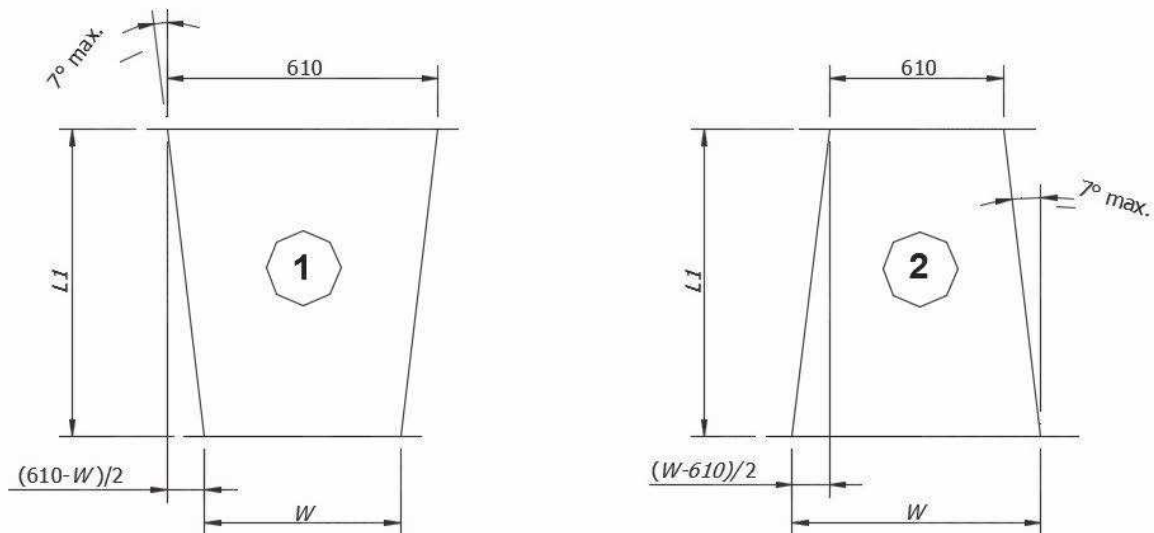

Figure 6 — Static pressure tap

### 7.1.10 Non 610 mm × 610 mm (24,0 inch × 24,0 inch) test devices

The test apparatus shown in [Figure 3](#) is designed for a test device with nominal face dimensions of 610 mm × 610 mm (24,0 inch × 24,0 inch). Transitions in accordance with [Figure 7](#) shall be used for test devices with face areas from 60 % to 150 % of the normal test rig cross section area of 0,37 m<sup>2</sup> (4 ft<sup>2</sup>). It is permitted to test a bank of several devices if the face area of an individual duplicating the structure of standard units if the size requirement cannot otherwise be met.

Dimensions in millimetres



#### Key

- 1 test device dimensions smaller than test rig (asymmetrical dimensions are allowed)
- 2 test device dimensions larger than test rig (asymmetrical dimensions are allowed)

Figure 7 — Transitions for test devices

### 7.1.11 Dust injection testing

#### 7.1.11.1 General

The dust injection device, U/S mixing orifice, and D/S final filter shown in [Figure 3](#) are for use if the test device is dust loaded as per ISO 16890-3 or any other dust loading procedure. Equipment locations and basic requirements are shown below. Additional specifications and requirements are detailed in ISO 16890-3. These devices are not used for measuring particle removal efficiency in this part of ISO 16890.

**NOTE** Even though this equipment is not used to measure the particle removal efficiency, the equipment is used to measure the filter element performance as per the ISO 16890-3 test method. Listing of the equipment and requirements are provided in ISO 16890-2 to help the user when assembling a test rig for both ISO 16890-2 and ISO 16890-3.

#### 7.1.11.2 Dust feeder

The dust feeder is located as shown in [Figure 3](#) as the dust injection nozzle. Specific setup, qualification and maintenance procedures for this equipment are listed in ISO 16890-3.

#### 7.1.11.3 U/S mixing orifice

For all dust load measurements, the U/S mixing orifice shall be installed as shown in [Figure 3](#), upstream of the test device and upstream of the U/S sample head. The dimensions and design shall be the same as shown for the D/S mixing orifice in [7.1.6](#) and shown in [Figure 4](#). If an inlet plenum is installed in the test rig, the orifice plate component in [Figure 4](#) can be eliminated. The perforated plate mixing baffle shall be installed and located as dimensioned in [Figure 4](#).

**NOTE** With an inlet plenum, the air is adequately mixed and use of only the perforated plate allows the dust to mix with a more uniform air flow distribution providing an even dust distribution on the face of the test device.

#### 7.1.11.4 Final filter

The final filter captures any loading dust that passes through the tested test device during the dust loading procedure. It is installed in place of the D/S mixing orifice when loading dust. The D/S mixing orifice shall be replaced when dust loading is completed and prior to any particle removal efficiency testing.

## 7.2 Aerosol particle counter

### 7.2.1 General

The aerosol particle counter shall be based on optical particle sizing and counting (i.e. light scattering). These instruments are commonly known as optical particle counter spectrometers (OPC) and also as optical aerosol spectrometers.

### 7.2.2 OPC sampled size range

The OPC(s) shall count and size individual aerosol particles in the 0,3  $\mu\text{m}$  to 3,0  $\mu\text{m}$  range for a minimum test data set or 0,3  $\mu\text{m}$  to 10,0  $\mu\text{m}$  range for a full data set. The counting efficiency of the OPC shall be  $\geq 50\%$  for 0,3  $\mu\text{m}$  particles.

### 7.2.3 OPC particle size ranges

The OPC shall have a minimum of eight logarithmically spaced particle size channels for the minimum test data set or 12 logarithmically spaced particle size channels for the full data set. There shall be a minimum of three particle size channels in each of the following size ranges: 0,3  $\mu\text{m}$  to 1,0  $\mu\text{m}$ , 1,0  $\mu\text{m}$

to 3,0 µm, and 3,0 µm to 10,0 µm. Particle size channel boundaries shall be located at 0,3 µm, 1,0 µm, 3,0 µm and 10,0 µm. The recommended particle size channels boundaries are shown in [Table 2](#).

**Table 2 — Recommended OPC(s) particle size range boundaries**

Size range	Lower limit µm	Upper limit µm	Geometric mean particle size limit µm
1	0,30 <sup>a</sup>	0,40	0,35
2	0,40	0,55	0,47
3	0,55	0,70	0,62
4	0,70	1,00 <sup>a</sup>	0,84
5	1,00 <sup>a</sup>	1,30	1,14
6	1,30	1,60	1,44
7	1,60	2,20	1,88
8	2,20	3,00 <sup>a</sup>	2,57
9	3,00 <sup>a</sup>	4,00	3,46
10	4,00	5,50	4,69
11	5,50	7,00	6,20
12	7,00	10,0 <sup>a</sup>	8,37

<sup>a</sup> Required channel boundaries.

#### 7.2.4 Sizing resolution

The sizing resolution of the OPC shall be  $\leq 8$  % (standard deviation/mean) and shall be measured in accordance with ISO 21501-1. The resolution shall be measured at a particle size in the 0,5 µm to 0,7 µm size range.

#### 7.2.5 Calibration

The OPC shall be calibrated in accordance with ISO 21501-4. The calibration shall be performed with monodisperse NIST-traceable PSL and the calibration shall include at least one particle diameter in each of the ranges of 0,3 µm to 0,4 µm, the upper most channel of the range to be tested (either 2,20 µm to 3,00 µm for the minimum data range or 7,00 µm to 10,00 µm for the full data set range), and at least four other sizes in between. The particle size calibration of the OPC shall be performed at least annually.

#### 7.2.6 Air flow rate

The inlet volume air flow rate shall not change more than 2 % with a 1 000 Pa (4,0 inch H<sub>2</sub>O) change in the pressure of the sampled air.

#### 7.2.7 Zero counting

The total measured particle count rate shall be less than 10 particles per minute when the OPC is sampling air with a high efficiency HEPA filter on the sample intake.

#### 7.2.8 Dual OPC(s)

Dual OPC(s) (one on the upstream sample and one on the downstream sample), if used, shall be identical models such that they are closely matched in design and sampling flow rate.

### 7.3 Temperature, relative humidity

The temperature measurement device shall be accurate to within  $\pm 1$  °C (1,8 °F). The relative humidity measurement device shall be accurate to within  $\pm 2$  %. The temperature and relative humidity measurement devices shall be calibrated yearly.

## 8 Qualification of test rig and apparatus

### 8.1 Schedule of qualification testing requirements

#### 8.1.1 General

Apparatus qualification tests shall verify quantitatively that the test rig and sampling procedures are capable of providing reliable fractional efficiency measurements and resistance to air flow measurements. Maintenance testing shall keep the system in good operating order. Additional cleaning and maintenance operations subject to any normal laboratory operation shall also be needed beyond what is listed in [Clause 8](#).

#### 8.1.2 Qualification testing

Full system qualification testing shall take place every two years or sooner if any change is made to the system that may alter performance, such as changing a major component of the system. It is suggested that the qualification test be performed in the order listed in [Table 3](#).

A change to the system requiring requalification would include, but is not limited to, changing the blower, reconfiguring the test rig dimensions, changing the locations of the OPC, generators, etc. Also, this order of testing should allow the user to minimize potential retesting due to modifications that may be required to pass sections of the qualification testing. For example, not knowing the aerosol generator response time could cause issues trying to pass the aerosol uniformity test.

#### 8.1.3 Qualification documentation

The test rig owner/operator shall always have a qualification testing report available documenting the results of the latest qualification testing.

**Table 3 — Qualification testing requirements**

Qualification testing	Subclause of this part of ISO 16890	Requirement
Test rig — Pressure system testing	<a href="#">8.2.1</a>	No change in Pa
OPC — Air flow rate stability test	<a href="#">8.2.2</a>	<5 % of the set sample air flow rate <2 % between U/S and D/S
OPC — Zero test	<a href="#">8.2.3</a>	<10 counts per minute from 0,30 µm to 10,0 µm
OPC — Sizing accuracy	<a href="#">8.2.4</a>	Relative to the max in the appropriate channel
OPC — Overload test	<a href="#">8.2.5</a>	No predetermined level
Aerosol reference matching <sup>a</sup>	<a href="#">6.3</a>	<2 % points in each channel
Aerosol generator — Response time	<a href="#">8.2.6</a>	No predetermined level
Aerosol generator — Neutralizer	<a href="#">8.2.7.1</a>	Radioactivity shall be detected
Aerosol neutralizer life time	<a href="#">8.2.7.2</a>	Replace if any decrease detected
<sup>a</sup> This test is required if an aerosol other than the reference one is used for a particle size range.		

Table 3 (continued)

Qualification testing	Subclause of this part of ISO 16890	Requirement
Aerosol neutralizer — Radioactive service life verification	<a href="#">8.2.7.3</a>	Document source strength when new Remaining life >185 Mbq (5 mCi)
Aerosol neutralizer — Radioactivity is present	<a href="#">8.2.7.4</a>	
Aerosol neutralizer — Corona discharge current	<a href="#">8.2.7.6</a>	≥3 µA
Aerosol neutralizer — Corona discharge balanced output	<a href="#">8.2.7.7</a>	As close as possible a reading of zero
Test rig — Air leakage test	<a href="#">8.2.8</a>	<1 %
Test rig — Air velocity uniformity	<a href="#">8.2.9</a>	CV < 10 %
Test rig — Aerosol uniformity	<a href="#">8.2.10</a>	CV < 15 %
Test rig — Downstream mixing	<a href="#">8.2.11</a>	CV < 10 %
Test rig — Empty test device section pressure	<a href="#">8.2.12</a>	<5 Pa (0,02 inch H <sub>2</sub> O)
Test rig — 100 % efficiency test	<a href="#">8.2.13</a>	>99 % for all particle sizes
Test rig — Correlation ratio	<a href="#">8.2.14</a>	0,30 µm to 1,0 µm: 0,90 to 1,10 1,0 µm to 3,0 µm: 0,80 to 1,20 3,0 µm to 10,0 µm: 0,70 to 1,30

<sup>a</sup> This test is required if an aerosol other than the reference one is used for a particle size range.

## 8.2 Qualification testing

### 8.2.1 Test rig — Pressure system testing

#### 8.2.1.1 Pressure system test protocol

The test shall be made by calibrated pressure measuring devices or by the system described in [Figure 8](#). Carefully seal the pressure sample points in the test rig to be able to withstand a negative pressure of 5 000 Pa (20,0 inch H<sub>2</sub>O). Disconnect the pressure sensor(s) and apply the negative pressure to each individual sample line until all sample pressure lines have been tested.

For each pressure sensor connected to the system, apply the maximum pressure allowed by the manufacturer to the sensor. This test shall be carried out sequentially on all pressure lines attached to the test rig.

**NOTE** The pressure system test is to verify the lines, connectors and equipment used to measure pressure in the test rig do not significantly affect the accuracy of the measurements of air flow rate or resistance to air flow.

#### 8.2.1.2 Pressure system test results

For each sample line or sensor port, after 30 s of testing there shall be no change in the pressure from the applied pressure value.

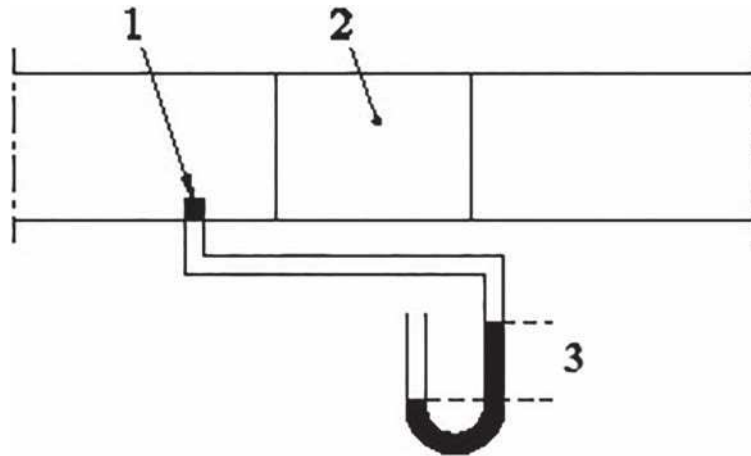

**Key**

- 1 sealed pressure inlet
- 2 test device section
- 3  $\Delta p = 5\,000\text{ Pa}$  (20,0 inch H<sub>2</sub>O)

**Figure 8 — Pressure system test**

**8.2.2 OPC — Air flow rate stability test**

**8.2.2.1 Air flow rate stability test protocol**

Install a very high resistance to air flow filtration device or a perforated plate which generates a minimum of 1 000 Pa (4,0 inch H<sub>2</sub>O) resistance to air flow between the upstream particle sampling location and the downstream particle sampling location at an air flow rate of 0,944 m<sup>3</sup>/s (2 000 ft<sup>3</sup>/min).

Measure the sampled air flow rate from the test rig at both the upstream and downstream sampling locations.

If using a secondary sampling system, both the air flow from the test rig and the air flow to the OPC shall be individually verified. Measure the sampled air flow rate through the OPC by either measuring the exhaust or the inlet air flow at both the upstream and downstream sampling locations.

**8.2.2.2 Air flow rate stability test results**

The air flow rate from the test rig at the upstream and downstream sampling locations shall be within 5 % of the set sample air flow rate. The difference between the sample air flow rate from the test rig for the upstream and downstream sample lines shall not exceed 2 %.

The air flow rate of the OPC using upstream and downstream sampling points shall be within 5 % of the instrument’s specified air flow rate. The difference between the sample air flow rate into the OPC from the upstream and downstream sample lines shall not exceed 2 %.

NOTE Differences in sample air flow through the OPC(s) can significantly alter measurement capabilities during a test. This potential issue is enhanced as the resistance to air flow in the test rig is increased.

**8.2.3 OPC — Zero test**

**8.2.3.1 Zero test protocol**

For each OPC on the system, install a minimum HEPA level efficiency filter directly to the instrument’s inlet and run a 1 min count.

### 8.2.3.2 Zero test results

The zero count of the OPC(s) shall be verified to be <10 total counts per minute in the 0,30 µm to 10,0 µm size range.

NOTE The ability of the OPC to zero count is a quick indication if maintenance is needed on the OPC.

## 8.2.4 OPC — Sizing accuracy

### 8.2.4.1 Sizing accuracy test protocol

The sizing accuracy of the OPC(s) shall be checked by sampling an aerosol containing monodisperse polystyrene spheres (PSL) of known particle size.

NOTE OPC(s) measure the particle count and the equivalent optical particle size. The indicated particle size is strongly dependent on the calibration of the OPC. Checks with PSL particles at the low and the high end of the OPC's particle size range are especially meaningful.

### 8.2.4.2 Sizing accuracy test results

A relative maximum particle count shall appear in the OPC sizing channel that encompasses the PSL particle diameter. This result is not intended to be an OPC calibration, but simply a sizing accuracy check of the OPC.

## 8.2.5 OPC — Overload test

### 8.2.5.1 General

OPCs may underestimate particle concentrations if their concentration limit is exceeded. Therefore, it is necessary to know the concentration limit of the OPC being used. The maximum aerosol concentration used in the tests shall then be kept sufficiently below the concentration limit, so that the counting error resulting from coincidence does not exceed 5 %.

NOTE The measured fractional efficiency in the 0,30 µm to 0,40 µm particle size range often decreases as the concentration begins to overload the OPC.

### 8.2.5.2 Overload test protocol

A series of initial fractional efficiency tests shall be performed over a range of challenge aerosol concentration to determine a total concentration level for the fractional efficiency test that does not overload the OPC(s). If the upstream concentration in the test rig cannot be reduced, a dilution system may be used to reduce the aerosol concentrations below the OPC's concentration limit. It is then necessary to take upstream and downstream samples via the dilution system in order to eliminate errors arising from uncertainty in the dilution factor's value. The lowest total concentration level shall be less than 1 % of the instrument's stated total concentration limit. The tests shall be performed following the procedures of [9.3](#) on a media-type air cleaner using a range of upstream aerosol concentrations. The tests shall be performed at 0,944 m<sup>3</sup>/s (2 000 ft<sup>3</sup>/min). The filters selected for this test shall have an initial fractional efficiency in the range of 30 % to 70 % as measured by the 0,30 µm to 0,40 µm particle size range and >90 % for the 7,0 µm to 10 µm particle size range. The aerosol for these tests shall be generated using the same system and procedures of [9.3](#).

### 8.2.5.3 Overload test results

The tests shall be performed over a sufficient range of total aerosol challenge concentrations to demonstrate that the OPC(s) is not overloaded at the intended test concentration. The measured filtration efficiencies should be equal over the concentration range where overloading is not significant.

## 8.2.6 Aerosol generator — Response time

### 8.2.6.1 Aerosol generator response time — Measurement protocol

Measure the time interval for the aerosol concentration to go from background level to steady-state test level. The test shall be performed at an air flow rate of 0,944 m<sup>3</sup>/s (2 000 ft<sup>3</sup>/min) with the OPC sampling from the upstream probe. Similarly, measure the time interval for the aerosol to return to background level after turning off the generator.

NOTE The aerosol generator response time determines the amount of time delay needed to reach a steady-state condition for testing. This is to ensure that sufficient time is allowed for the aerosol concentration to stabilize prior to beginning the upstream/downstream sampling sequence during the filter testing.

Use the aerosol generator defined in 6.1.4 and the OPC defined in 7.2 to find the aerosol generator response times for liquid phase aerosol. Repeat this test using the solid phase aerosol generator in 6.2.4.

### 8.2.6.2 Aerosol generator response time results

These time intervals shall be used as the minimum waiting time between (a) activating the aerosol generator and beginning the OPC sampling sequence and (b) deactivating the aerosol generator and beginning the OPC sampling sequence for determination of background aerosol concentrations.

## 8.2.7 Aerosol generator — Neutralizer

### 8.2.7.1 Aerosol neutralizer test protocol

Test the activity of the alpha or beta radiation source with an appropriate radiation detection device. If a corona discharge ionizer is used, it should have a minimum corona current of 3 μA and shall be balanced to provide equal amounts of positive and negative ions.

NOTE When testing filters with a solid phase aerosol electrostatic charge on, the aerosol can affect the test results. Thus, neutralizing the solid phase aerosol is a necessary procedure.

### 8.2.7.2 Aerosol neutralizer life time

The measurement shall be repeated annually and compared to prior measurements to determine if a substantial decrease in activity has occurred. Replace neutralizers showing a lack of activity in accordance with the manufacturer's recommendations.

### 8.2.7.3 Aerosol neutralizer — Radioactive service life verification

Verify, based on the original radioactivity of the source, the source's radioactive half-life, and the time passed from date of manufacture, that the current radioactivity of the source is above 185 MBq (5 mCi).

$$Ra = Ra_0 \cdot 2^{-\frac{t}{t_{0,5}}} > 185 \text{ MBq (5 mCi)} \quad (1)$$

where

*Ra* current radioactivity of the source, MBq (mCi);

*Ra*<sub>0</sub> original radioactivity of the source (at date of manufacture), MBq (mCi);

*t* elapsed time since date of manufacture (years);

*t*<sub>0,5</sub> half-life of the source (years).



**8.2.7.4 Aerosol neutralizer — Radioactivity is present**

A radiation detector shall be used to confirm that radioactivity is detected within the neutralizer.

**8.2.7.5 Aerosol neutralizer — Radioactive clean**

Radioactive aerosol neutralizers shall be cleaned at a minimum of every two weeks. Rinse with water if KCl aerosol is used. Use appropriate solvent if oil aerosol is used.

**8.2.7.6 Aerosol neutralizer — Corona discharge current**

The aerosol neutralizer current for corona discharge devices shall be measured as part of qualification and as part of each test. The minimum corona current shall be 3  $\mu$ A.

**8.2.7.7 Aerosol neutralizer — Corona discharge balanced output**

The neutralizer output shall be checked for balance at a minimum of every two weeks. Remove neutralizer from the spray tower, but leave it attached to the drying air source. Support neutralizer 300 mm from any object except for a small support arm that is on the side or rear of the neutralizer. Start drying air flow 1,9 dm<sup>3</sup>/s (4 ft<sup>3</sup>/min). Hold static voltmeter 305 mm (12,0 inch) in front of the neutralizer in the centre of the air stream exiting the neutralizer. If the positive and negative outputs are user-adjustable, adjust the positive and negative output to obtain as close as possible a reading of zero. If the positive or negative outputs were adjusted, repeat the measurement of corona discharge current and confirm that the minimum corona current specified is still achieved.

**8.2.7.8 Aerosol neutralizer — Corona discharge clean corona source**

The corona discharge points shall be inspected at a minimum of every two weeks and cleaned if needed.

**CAUTION — Disconnect ion source from power supply and refer to the manufacturer's safety requirements prior to cleaning the corona neutralize.**

**8.2.8 Test rig — Air leakage test****8.2.8.1 General**

The test rig can be operated either under negative or positive pressure depending on the fan location. In the case of positive pressure operation (i.e. the fan upstream of the test device in the test rig), the test aerosol could leak into the laboratory, while at negative pressure particles could leak into the test system. Either method has the potential to affect the test results unless the overall test rig leakage rate is very low.

**8.2.8.2 Air leakage test protocol**

The test rig shall be sealed at the beginning of the 610 mm × 610 mm (24,0 inch × 24,0 inch) section and immediately upstream of the exhaust filter bank by attaching a gasketed solid plate to the test rig opening or other appropriate means. It is acceptable to apply the seals to a larger length of the test rig, but not less than prescribed. If a larger test rig length is included, the system shall still meet the same leakage requirements. To establish the pressure for the leak test, the pressure at the aerosol injection location shall be measured with the test rig operating at air flow rates of 0,236 m<sup>3</sup>/s, 0,944 m<sup>3</sup>/s and 1,416 m<sup>3</sup>/s (500 ft<sup>3</sup>/min, 2 000 ft<sup>3</sup>/min, and 3 000 ft<sup>3</sup>/min) without a test device installed. To determine the test pressures, add 250 Pa (1,0 inch H<sub>2</sub>O) to the measured pressures to account for the added resistance of an air cleaner.

**8.2.8.3 Air leakage test results**

Carefully measure the amount of air entering into the test rig until the lowest test pressure is achieved. The air flow rate required to maintain the pressure at a constant value shall be measured and recorded

as the leak rate, and the test shall then be repeated for the other two test pressures. The measured leak rates shall not exceed 1,0 % of the corresponding test air flow rate. The highest pressure anticipated by this part of ISO 16890 is 3 200 Pa (13 inch H<sub>2</sub>O). The user should exercise caution and should not pressurize the test rig beyond its design limit for personal safety.

## 8.2.9 Test rig — Air velocity uniformity

### 8.2.9.1 Air velocity parameters

The uniformity of the challenge air velocity across the test rig cross section shall be determined by a nine-point traverse ([Figure 9](#)) in the 610 mm × 610 mm (24,0 inch × 24,0 inch) test rig immediately upstream of the test device section without any test device installed in the test device section. The uniformity test shall be performed at air flow rates of 0,236 m<sup>3</sup>/s, 0,944 m<sup>3</sup>/s and 1,416 m<sup>3</sup>/s (500 ft<sup>3</sup>/min, 2 000 ft<sup>3</sup>/min, and 3 000 ft<sup>3</sup>/min). The velocity measurements shall be made with an instrument having a minimum accuracy of 10 % with a minimum resolution of 0,05 m/s (10 ft/min).

NOTE If the air velocity is not uniform in the test rig, the results of resistance to air flow and fractional efficiency testing can have higher variability than expected.

### 8.2.9.2 Air velocity protocol

A one-minute average velocity shall be recorded at each grid point ([Figure 9](#)). The average shall be based on at least 10 readings taken at equal intervals during the one-minute period. The traverse shall then be repeated two more times to provide triplicate one-minute averages at each point for the given air flow rate. The average of the triplicate readings at each point shall be computed.

### 8.2.9.3 Air velocity results

The *CV* (where *CV* is the coefficient of variation, computed as the standard deviation/mean) of the nine corresponding averaged grid point air velocity values shall be less than 10 % at each air flow rate.

The coefficient of variation *CV* shall be calculated as follows:

$$CV = \frac{\delta}{mean} \quad (2)$$

where

$\delta$  is the standard deviation of the nine averaged measuring points;

*mean* is the mean value of the nine measuring points.

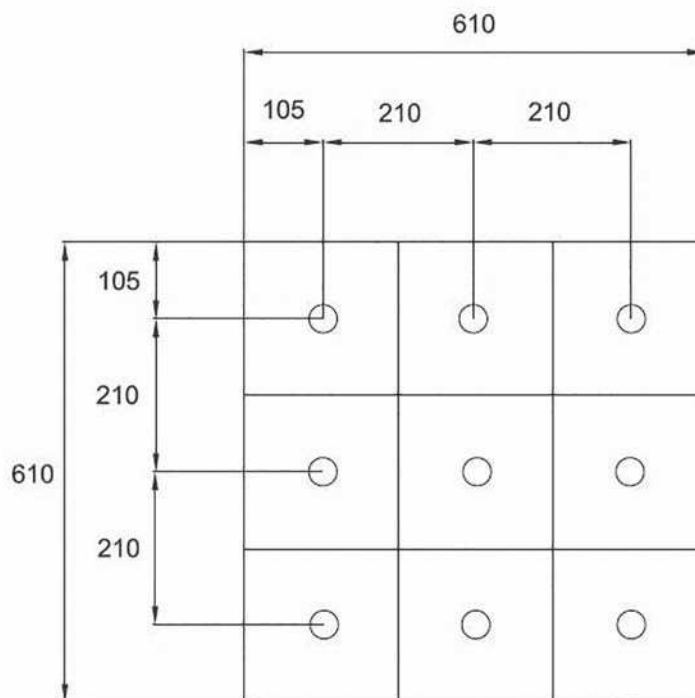

Figure 9 — Air velocity and aerosol uniformity sampling points

### 8.2.10 Test rig — Aerosol uniformity

#### 8.2.10.1 Aerosol uniformity parameters

The uniformity of the challenge aerosol concentration across the test rig cross section shall be determined by a nine-point traverse in the 610 mm × 610 mm (24,0 inch × 24,0 inch) test rig immediately upstream of the test device location using the grid points as shown in [Figure 9](#).

The traverse measurements shall be performed at air flow rates of 0,236 m<sup>3</sup>/s, 0,944 m<sup>3</sup>/s and 1,416 m<sup>3</sup>/s (500 ft<sup>3</sup>/min, 2 000 ft<sup>3</sup>/min, and 3 000 ft<sup>3</sup>/min). The traverse shall be made by repositioning a single probe to maintain the same sample line configuration for each of the nine grid points. The inlet nozzle of the sample probe shall be a tapered sharp edged sample probe and meet the requirements of [7.1.7.2](#) for isokinetic sampling at 0,944 m<sup>3</sup>/s (2 000 ft<sup>3</sup>/min). This same inlet nozzle diameter shall be used at all air flow rates.

NOTE If the aerosol distribution is not uniform in the test rig, the results of fractional efficiency testing can have higher than expected variability.

#### 8.2.10.2 Aerosol uniformity protocol

A minimum of a one-minute sample shall be taken at each grid point with the aerosol generator operating. After sampling all nine points, the traverse shall be repeated four more times to provide a total of five samples from each point. The five values for each point shall then be averaged for each of the 12 OPC size channels. The measurements shall be made with an OPC meeting the specifications shown in [7.2](#). The number of particles counted in a specified size range in a single measurement shall be >100 in order to reduce the statistical error. If both solid and liquid aerosols are used in testing, both aerosol systems shall meet this qualification requirement.

### 8.2.10.3 Aerosol uniformity results

The *CV* of the corresponding nine grid point particle concentrations shall be less than 15 % for each air flow rate in each of the 12 OPC size channels.

The coefficient of variation *CV* shall be calculated for each particle size range at each flow as follows:

$$CV_{ps} = \frac{\delta_{ps}}{mean_{ps}} \quad (3)$$

where

$\delta_{ps}$  is the standard deviation (of the nine measuring points) for particle size range, *ps*;

$mean_{ps}$  is the mean value of the nine measuring points for particle size range, *ps*.

### 8.2.11 Test rig — Downstream mixing

#### 8.2.11.1 Downstream mixing parameters

The point of aerosol injection immediately downstream of the test device section shall be traversed using the grid points as shown in [Figure 10](#). The downstream sampling probe shall remain stationary in its normal centre of test rig sampling location. A HEPA filter with face dimensions of 610 mm × 610 mm (24,0 inch × 24,0 inch) shall be installed to obtain smooth air flow at the outlet of the test device section.

The downstream mixing measurements shall be performed at air flow rates of 0,236 m<sup>3</sup>/s, 0,944 m<sup>3</sup>/s and 1,416 m<sup>3</sup>/s (500 ft<sup>3</sup>/min, 2 000 ft<sup>3</sup>/min, and 3 000 ft<sup>3</sup>/min). An aerosol nebulizer shall nebulize a KCl/water solution (prepared using a ratio of 300 g of KCl to 1 000 ml water) into an aerosol of primarily sub micrometre sizes. A rigid extension tube with a length sufficient to reach each of the injection points shall be affixed to the nebulizer outlet. A 90° bend shall be placed at the outlet of the tube to allow injection of the aerosol in the direction of the air flow. The injection probe shall point downstream. The aerosol shall be injected immediately downstream within 250 mm (10,0 inch) of the HEPA filter at preselected points located around the perimeter of the test rig and at the centre of the test rig as indicated in [Figure 10](#). The flow rate through the nebulizer and the diameter of the injection tube outlet shall be adjusted to provide an injection air velocity within ±50 % of the mean test rig velocity. The downstream aerosol concentration shall be measured as total aerosol concentration >0,30 µm.

NOTE 1 A downstream mixing test is performed to ensure that aerosol that penetrates the air cleaner (media or frame) is detectable by the downstream sampler.

NOTE 2 The nebulizer can be of any kind that produces a stable submicrometer aerosol and is not required to be the same aerosol generator used to generate the 0,30 µm to 10,0 µm challenge aerosol for the efficiency test. A small hand-held nebulizer facilitates the traversing process.

NOTE 3 The combination of (a) evaluating the downstream concentration as the total concentration >0,30 µm and (b) the use of a portable nebulizer greatly simplify and speed up the process of the test while maintaining the utility to detect inadequate downstream mixing.

#### 8.2.11.2 Downstream mixing protocol

A one-minute sample from the downstream probe shall be acquired with the nebulizer operating and the injection tube positioned at the first injection grid point. The injection point shall then be moved to the next grid point location. A new one-minute sample shall be obtained after waiting at least 30 s. The procedure shall be repeated until all nine grid points have been sampled two more times to provide triplicate measurements at each grid point for the given air flow rate. The average of the triplicate readings at each point shall be computed.

### 8.2.11.3 Downstream mixing results

The  $CV$  of the corresponding nine grid point particle concentrations shall be less than 10 % for each air flow rate in each of the 12 OPC particle size ranges. If the required degree of downstream aerosol mixing is not achieved, verify that the downstream mixing orifice and baffle are properly designed and centred. Confirm that the aerosol nebulizer provides a stable output by injecting the aerosol at the centre of the test rig location while repeatedly sampling downstream. Improve the stability of the aerosol nebulizer if needed and repeat the downstream mixing test.

The coefficient of variation  $CV$  shall be calculated for each particle size range at each flow as follows:

$$CV_{ps} = \frac{\delta_{ps}}{mean_{ps}} \quad (4)$$

where

$\delta_{ps}$  is the standard deviation (of the nine measuring points) for particle size range,  $ps$ ;

$mean_{ps}$  is the mean value of the nine measuring points for particle size range,  $ps$ .

Dimensions in millimetres

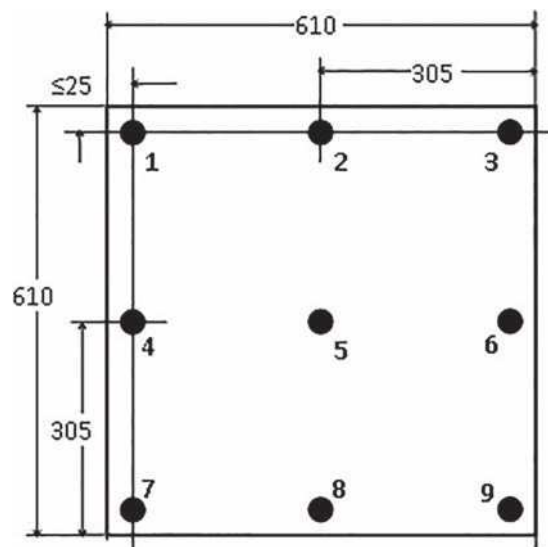

Figure 10 — Downstream mixing aerosol injection grid

### 8.2.12 Test rig — Empty test device section pressure

#### 8.2.12.1 Empty test device section protocol

Set the test rig air flow rate to 0,944 m<sup>3</sup>/s (2 000 ft<sup>3</sup>/min) with no test device in the test device section. Record the resistance to air flow of the empty test device section.

#### 8.2.12.2 Empty test device section pressure results

The measured resistance to air flow across the empty test device section shall be less than 5 Pa (0,02 inch H<sub>2</sub>O). System maintenance shall be performed until the resistance to air flow is below this level.

NOTE Since there is a linear distance between the upstream and downstream pressure sampling points, there can be a small tare pressure or system effect due to this distance and the movement of the air. The system tare does not include any filter mounting hardware which may be used to hold the filter in a normal installation, [5.2](#).

### 8.2.13 Test rig — 100 % efficiency test and purge time

#### 8.2.13.1 100 % efficiency protocol

An initial fractional efficiency test shall be performed using a filter element with an efficiency of at least HEPA according to ISO 29463-1 as the test device. The test procedures for determination of fractional efficiency given in [9.3](#) shall be followed and the test shall be performed at an air flow rate of 0,944 m<sup>3</sup>/s (2 000 ft<sup>3</sup>/min).

One parameter affecting the efficiency during the 100 % efficiency test is the purge time. The purge time is too short if, after switching from the upstream to the downstream line, residual particles from the upstream sample are counted during the downstream sampling and yield an efficiency of <99 %. In this case, the purge time shall be increased and the 100 % efficiency test repeated.

**NOTE** The purpose of this test is to ensure that the test rig and sampling system are capable of providing a 100 % efficiency measurement. In addition, this test assesses the adequacy of the aerosol generator response time from [8.2.6](#). If the response time is insufficient, residual particles from the relatively high concentration upstream sample appear in the downstream sample.

#### 8.2.13.2 100 % efficiency results

The fractional efficiency shall be greater than 99 % for all particle sizes. Determine an acceptable purge time to meet this test requirement and double the time needed as a safety factor. Use this safety factor value as the test purge time.

### 8.2.14 Test rig — Correlation ratio

#### 8.2.14.1 General

The correlation ratio test shall be performed without a test device in place to check the adequacy of the overall test rig, sampling, measurement and aerosol generator.

**NOTE** In a perfect system, the correlation ratios are 1,0 at all particle sizes. Deviations from 1,0 can occur due to particle losses in the test rig, differences in the degree of aerosol uniformity (i.e. mixing) at the upstream and downstream probes, and differences in particle transport efficiency in the upstream and downstream sample lines.

#### 8.2.14.2 Correlation ratio protocol

The test shall be performed as a normal fractional efficiency test but with no test device installed. The test air flow rate shall be 0,944 m<sup>3</sup>/s (2 000 ft<sup>3</sup>/min). The test procedures for determination of the correlation ratio in [9.3](#) shall be followed.

#### 8.2.14.3 Correlation ratio results

The correlation ratio for each particle size shall meet the data quality requirements from [10.3.3](#).

**NOTE** If the correlation ratio falls outside of the required specification at the smaller particle sizes (<1,0 µm), suspect incomplete mixing at the upstream probe location; the aerosol injection tube may need to be realigned or additional mixing provided in the discretionary ductwork upstream of the upstream mixing orifice. If the small particles are within required limits but the larger particles are not, suspect unequal sample line losses. For dual OPC systems, also suspect that one of the OPCs may be out of calibration or have air flow issues.

## 8.3 Maintenance

### 8.3.1 General

Apparatus maintenance testing gives the user a way to check the system on a regular basis and keep it in good operating order. Additional cleaning and maintenance operations subject to any normal

laboratory operation shall also be needed beyond what is listed in 8.3. The maintenance schedule is shown in Table 4. Items are shown based on the proper time to perform each maintenance item with references to the appropriate subclause of this part of ISO 16890. Several items listed here are also part of the qualification test requirements, but are listed here as they shall be performed and documented more often than the qualification requirement.

**Table 4 — Maintenance schedule**

Maintenance items	Subclause of this part of ISO 16890	Each test	Two weeks	Monthly	Six months	Yearly
Test rig — Correlation ratio	<a href="#">8.2.14</a>	X				
Test rig — Empty test device section pressure	<a href="#">8.2.12</a>	X				
Test rig — Background counts	<a href="#">8.3.2</a>	X				
OPC — Zero test	<a href="#">8.2.3</a>	X				
OPC — Sizing accuracy	<a href="#">8.2.4</a>	X				
Test rig — Reference filter test	<a href="#">8.3.3</a>		X			
Test rig — Pressure reference test	<a href="#">8.3.4</a>		X			
Test rig — 100 % efficiency test	<a href="#">8.2.13</a>			X		
Test rig — Final filter resistance <sup>a</sup>	<a href="#">8.3.5</a>			X		
Test rig — Pressure system testing	<a href="#">8.2.1</a>				X	
Aerosol generator — Response time	<a href="#">8.2.6</a>				X	
OPC — Calibration	<a href="#">7.2.5</a>					X
Pressure sensors — Calibration	<a href="#">7.1.9</a>					X
Temperature, RH — Calibration	<a href="#">7.3</a>					X
Air flow rate measurement — Calibration	<a href="#">7.1.8</a>					X
Aerosol generator — Response time	<a href="#">8.2.6</a>				X	
Aerosol neutralizer — Remaining radioactivity	<a href="#">8.2.7.3</a>					X
Aerosol neutralizer — Confirmation of radioactivity	<a href="#">8.2.7.4</a>		X			
Aerosol neutralizer — Radioactive clean	<a href="#">8.2.7.5</a>		X			
Aerosol neutralizer — Corona discharge current	<a href="#">8.2.7.6</a>	X				
Aerosol neutralizer — Corona discharge output	<a href="#">8.2.7.7</a>		X			
Aerosol neutralizer — Corona discharge inspect and clean if needed	<a href="#">8.2.7.8</a>		X			
NOTE Regular cleaning of all equipment is needed to maintain the performance of the test rig.						
<sup>a</sup> For this part of ISO 16890, the final filter is not used.						

### 8.3.2 Test rig — Background counts

Test rig background counts are part of the normal fractional efficiency testing process defined in 9.3.1. Regular monitoring of these results enable the test rig owner/operator to find potential issues with the system before they become a problem.

NOTE Increases in the background counts could be a sign of an intake HEPA filter problem, an OPC problem, or even a test rig leakage problem.

### 8.3.3 Test rig — Reference filter test

#### 8.3.3.1 Reference filters

For each test rig, a minimum of three identical reference filters shall be maintained by the testing facility solely for initial fractional efficiency testing on a biweekly basis. The reference filter shall be of structurally stable design. The fractional efficiency of the reference filters shall pass through 50 % efficiency in the particle diameter range of 0,7 µm to 3,0 µm and be <35 % at 0,30 µm to 0,40 µm and >70 % in the 7,0 µm to 10,0 µm range. The three reference filters shall be labelled as “primary,” “secondary” and “reserve.” These reference filters shall remain protected when not in use and stored in a safe place from potential damage.

Testing a known reference filter for fractional efficiency enables the test rig owner/operator to find potential issues with the system before they become a problem. Detecting shifts in the efficiency curves becomes difficult if the efficiency is either very high or very low for all particle sizes. Changes in the filtration efficiency of electret media reference filters may be due to reduced effectiveness of the neutralizer and its condition should then be checked.

#### 8.3.3.2 Reference protocol

The “primary” reference filter shall be tested at an air flow rate of 0,944 m<sup>3</sup>/s (2 000 ft<sup>3</sup>/min) for fractional efficiency as defined in [9.3](#) every two weeks. If the fractional efficiency values shift by >5 percentage points for any of the particle sizing channels, the “secondary” reference filter shall be tested. If both the primary and secondary reference filters show shifts >5 percentage points for any of the particle sizing channels, system maintenance shall be performed as needed (e.g. clean sample lines, recalibrate the OPC, etc.) to restore the reference filter fractional efficiency test to a <5 percentage point shift. The “reserve” reference filter shall be used if either the primary or secondary reference filter becomes unusable (e.g. damaged).

NOTE Percentage points is not to be confused with percent. As an example, the difference between efficiency values of 30 % and 35 % is 5 percentage points, not 5 %.

#### 8.3.3.3 Reference values

The reference filters shall be tested as defined in [9.3](#) for fractional efficiency and resistance to air flow. These initial values shall be the reference values for that reference filter.

#### 8.3.3.4 Reference resistance to air flow

The measured resistance to air flow across the reference filter shall be within 10 % of the reference value for that reference filter. If the resistance to air flow deviates by more than 10 %, system maintenance shall be performed to restore the resistance to air flow to within 5 % of the reference value.

NOTE Examples of system maintenance steps that can be performed to restore the resistance to air flow include (but are not limited to) checking for leaks in the ducting and around the flow nozzle, and checking the manometer for proper zero and level.

#### 8.3.3.5 OPC recalibration

Immediately after recalibration of the OPC(s), retest each of the reference filters (or a new set of reference filters) to establish new fractional efficiency and resistance to air flow reference values.

#### 8.3.3.6 Reference filter replacement

When either the primary or secondary reference filter shows a shift >5 percentage points for any of the particle size ranges and the secondary or reserve reference filter does not show the shift, the primary



and/or secondary reference filter shall be replaced with an identical filter or filters, if available, or a new set of identical reference filters shall be obtained.

NOTE A reference filter's efficiency may change with the collection of test aerosol after repeated use.

#### 8.3.4 Test rig — Pressure reference test

Testing the resistance to air flow as defined in 9.2 of a perforated plate (or other reference) having known resistance to air flow values at a minimum of four air flow rate data points between 0,472 m<sup>3</sup>/s (1 000 ft<sup>3</sup>/min) and 1,416 m<sup>3</sup>/s (3 000 ft<sup>3</sup>/min) shall be used as a resistance to air flow reference. The reference filter defined in 8.3.3 can be used for this test. It is recommended to use a test device with stable resistance to air flow over repeated use as the pressure reference device.

#### 8.3.5 Test rig — Final filter resistance

For this part of ISO 16890, the final filter is not used, but it may be used if this test rig is used to perform dust loading procedures in accordance with ISO 16890-3 or other standards. The final filter should be checked on a monthly basis at a typical air flow rate of 0,944 m<sup>3</sup>/s (2 000 ft<sup>3</sup>/min) and the resistance to air flow should not exceed 500 Pa (2,0 inch H<sub>2</sub>O). If the resistance to air flow exceeds this level, the final filter should be replaced.

## 9 Test methods

### 9.1 Air flow rate

The test device shall be tested at its nominal air volume flow rate for which the device has been specified by the manufacturer.

If the manufacturer does not specify a nominal air volume flow rate, the test device shall be tested at 0,944 m<sup>3</sup>/s (2 000 ft<sup>3</sup>/min). The air flow velocity associated with this volumetric flow is 2,54 m/s (500 ft/min). Unless otherwise specified, the test shall be performed at 0,944 m<sup>3</sup>/s (2 000 ft<sup>3</sup>/min).

For test devices that are not nominal 610 mm × 610 mm (24,0 inch × 24,0 inch) in face area, the nominal face area shall be multiplied by 2,54 m/s (500 ft/min) to get the test air flow rate.

### 9.2 Measurement of resistance to air flow

Install the test device in the test rig and record the value for the initial resistance to air flow when the test rig air flow has stabilized to each of 50 %, 75 %, 100 % and 125 % of the test air flow rate. These values will establish a curve of resistance to air flow as a function of the air flow rate. The resistance to air flow readings shall be corrected to an air density of 1,20 kg/m<sup>3</sup> (0,075 lb/ft<sup>3</sup>) (see Annex B).

### 9.3 Measurement of fractional efficiency

#### 9.3.1 Aerosol sampling protocol

All particle counting samples shall be a minimum of 30 s sample time and all particle count samples for any test shall be at the same sample time. The number of counts can be increased from the minimum values shown in 9.3.3 or 9.3.4, and the sample time for a test can be increased from the minimum value, as long as the sample time for each count remains the same throughout the test.

NOTE Increasing the number of counts and using longer sample times may improve statistical variability.

#### 9.3.2 Background sampling

Begin the initial background sampling after the test device is properly installed, the air flow has stabilized to the test air flow rate, and the aerosol generator is off. The final background sampling is

run at the test device air flow rate, after the fractional efficiency testing, and with the aerosol generator off. Each particle count for the background sampling shall have a minimum sample time of 30 s and all background particle counts shall have the same sample time as the fractional efficiency counts. The average background count shall be less than 5 % of the average measured upstream count during the filter element test.

NOTE Cleaning the inside surface of the test duct both upstream and downstream of the test device section and sampling lines may help if the average background count is more than 1 % of the average measured upstream count.

### 9.3.3 Testing sequence for a single OPC

#### 9.3.3.1 Single OPC sequence description

- a) Install the test device, unless this is a correlation test, then no test device is installed.
- b) Start the air flow and let stabilize.
- c) Measure the beginning background counts.
  - 1) Purge the upstream/downstream lines according to the purge time value determined from [8.2.13.2](#).
  - 2) Sample the upstream ( $B_{b,1}$ ) background particles.
  - 3) Purge the upstream/downstream lines.
  - 4) Sample the downstream ( $d_b$ ) background particles.
  - 5) Purge the upstream/downstream lines.
  - 6) Sample the upstream ( $B_{b,2}$ ) background particles.
- d) Start the aerosol generator and let stabilize as per the time determined in [8.2.6](#).
- e) Measure efficiency counts. Repeat [9.3.3.1 e\)](#) until 5 upstream and 5 downstream counts have been sampled.
  - 1) Purge the upstream/downstream lines.
  - 2) Sample the upstream ( $N_x$ ) particles.
  - 3) Purge the upstream/downstream lines.
  - 4) Sample the downstream ( $D_x$ ) particles.
- f) Measure the final upstream efficiency count.
  - 1) Purge the upstream/downstream lines.
  - 2) Sample the final upstream ( $N_6$ ) particles.
- g) Stop the aerosol generator and let stabilize as per the time determined in [8.2.6](#).
- h) Measure the final background counts.
  - 1) Purge the upstream/downstream lines.
  - 2) Sample the upstream ( $B_{f,1}$ ) background particles.
  - 3) Purge the upstream/downstream lines.
  - 4) Sample the downstream ( $d_f$ ) background particles.

- 5) Purge the upstream/downstream lines.
- 6) Sample the upstream ( $B_{f,2}$ ) background particles.
- i) Check the data quality requirements as defined in 10.3.
  - 1) If the data quality requirements are good, stop the air flow and remove the test device.
  - 2) If the data quality requirements are not acceptable, repeat items c) to h) as a complete set and use all data collected in the data quality calculations.

**Table 5 — Single OPC counting cycle for a size range,  $ps$**

Background, beginning				Gen On	1	2	3	4	5	6	7	8	9	10	11	Gen Off	Background, final							
U/S	Purge	$B_{b,1,ps}$	Purge		$B_{b,2,ps}$	Purge	$N_{1,ps}$	Purge	$N_{2,ps}$	Purge	$N_{3,ps}$	Purge	$N_{4,ps}$	Purge	$N_{5,ps}$		Purge	$N_{6,ps}$	Purge	$B_{f,1,ps}$	Purge	$B_{f,2,ps}$		
D/S	Purge		Purge	$d_{b,ps}$	Purge		$D_{1,ps}$	Purge		$D_{2,ps}$	Purge		$D_{3,ps}$	Purge		$D_{4,ps}$	Purge		$D_{5,ps}$	Purge		$d_{f,ps}$	Purge	

**9.3.3.2 Single OPC initial data reduction**

For a single OPC system, the upstream counts from two samples shall be averaged to obtain an estimate of the upstream counts that would have occurred at the same time as the downstream counts were taken.

For the upstream beginning and final background counts:

$$U_{B,b,ps} = \frac{B_{b,i,ps} + B_{b,(i+1),ps}}{2} \tag{5}$$

$$U_{B,f,ps} = \frac{B_{f,i,ps} + B_{f,(i+1),ps}}{2} \tag{6}$$

where

- $U_{B,b,ps}$  is the beginning upstream background average count for particle size,  $ps$ ;
- $U_{B,f,ps}$  is the final upstream background average count for particle size,  $ps$ ;
- $B_{b,i,ps}$  is the measured beginning upstream background count for particle size,  $ps$ ;
- $B_{f,i,ps}$  is the measured final upstream background count for particle size,  $ps$ .

The upstream background counts before and after the efficiency or correlation samples shall simply be averaged.

$$U_{B,c,ps} \text{ or } U_{B,ps} = \frac{U_{B,b,ps} + U_{B,f,ps}}{2} \tag{7}$$

where

- $U_{B,ps}$  is the upstream background average count for efficiency sample,  $i$ , and for particle size,  $ps$ ;
- $U_{B,c,ps}$  is the upstream background average count for correlation sample,  $i$ , and for particle size,  $ps$ ;
- $U_{B,b,ps}$  is the beginning upstream background average count for sample,  $i$ , and for particle size,  $ps$ ;
- $U_{B,f,ps}$  is the final upstream background average count for sample,  $i$ , and for particle size,  $ps$ .

The downstream background counts before and after the efficiency or correlation samples shall simply be averaged.

$$D_{B,c,ps} \text{ or } D_{B,ps} = \frac{d_{b,ps} + d_{f,ps}}{2} \quad (8)$$

where

- $D_{B,ps}$  is the downstream background average count for efficiency sample,  $i$ , and for particle size,  $ps$ ;
- $D_{B,c,ps}$  is the downstream background average count for correlation sample,  $i$ , and for particle size,  $ps$ ;
- $d_{b,ps}$  is the beginning downstream background average count for particle size,  $ps$ ;
- $d_{f,ps}$  is the final downstream background average count for particle size,  $ps$ .

For the upstream efficiency counts:

$$U_{i,ps} = \frac{N_{i,ps} + N_{(i+1),ps}}{2} \quad (9)$$

where

- $U_{i,ps}$  is the upstream efficiency average for sample,  $i$ , and for particle size,  $ps$ ;
- $N_{i,ps}$  is the measured upstream efficiency count for sample,  $i$ , and for particle size,  $ps$ .

### 9.3.4 Testing sequence for dual OPC testing

#### 9.3.4.1 Dual OPC sequence description

- a) Install the test device, unless this is a correlation test, then no test device is installed.
- b) Start the air flow and let stabilize.
- c) Measure the beginning background counts.
  - 1) Purge the upstream/downstream lines as per the purge time value determined from [8.2.13.2](#).
  - 2) Sample the upstream ( $U_{B,b,1}$ ) and downstream ( $d_{b,1}$ ) background particles.
- d) Start the aerosol generator and let stabilize as per the time determined in [8.2.6](#)
- e) Measure efficiency counts. Repeat [9.3.4.1 e\)](#) until 5 upstream and 5 downstream counts have been sampled.
  - 1) Purge the upstream/downstream lines.
  - 2) Sample the upstream ( $U_i$ ) and the downstream ( $D_i$ ) particles.
- f) Stop the aerosol generator and let stabilize as per the time determined in [8.2.6](#).
- g) Measure the final background counts.
  - 1) Purge the upstream/downstream lines.

- 2) Sample the upstream ( $U_{B,f,1}$ ) and the downstream ( $d_{f,1}$ ) background particles.
- h) Check the data quality requirements as defined in 10.3.
  - 1) If the data quality requirements are good, stop the air flow and remove the test device.
  - 2) If the data quality requirements are not acceptable, repeat items c) to g) as a complete set and use all data collected in the data quality calculations.

**Table 6 — Dual OPC counting cycle for a size range  $ps$**

		Background, beginning		Gen On						Gen Off	Background, final	
U/S	Purge	$U_{B,b,ps}$			1	2	3	4	5		$U_{B,f,ps}$	
D/S	Purge	$d_{b,ps}$		$D_{1,ps}$	$D_{2,ps}$	$D_{3,ps}$	$D_{4,ps}$	$D_{5,ps}$	$d_{f,ps}$			

**9.3.4.2 Dual OPC background calculations**

The upstream background counts before and after the efficiency or correlation samples shall simply be averaged.

$$U_{B,c,ps} \text{ or } U_{B,ps} = \frac{U_{B,b,ps} + U_{B,f,ps}}{2} \tag{10}$$

where

- $U_{B,ps}$  is the upstream background average efficiency count for particle size,  $ps$ ;
- $U_{B,c,ps}$  is the upstream background average correlation count for particle size,  $ps$ ;
- $U_{B,b,ps}$  is the beginning upstream background average count for particle size,  $ps$ ;
- $U_{B,f,ps}$  is the final upstream background average count for particle size,  $ps$ .

The downstream background counts before and after the efficiency or correlation samples shall simply be averaged.

$$D_{B,c,ps} \text{ or } D_{B,ps} = \frac{d_{b,ps} + d_{f,ps}}{2} \tag{11}$$

where

- $D_{B,ps}$  is the downstream background average efficiency count for particle size,  $ps$ ;
- $D_{B,c,ps}$  is the downstream background average correlation count for particle size,  $ps$ ;
- $d_{b,ps}$  is the beginning downstream background average count for particle size,  $ps$ ;
- $d_{f,ps}$  is the final downstream background average count for particle size,  $ps$ .

## 10 Data reduction and calculations

### 10.1 Correlation ratio

#### 10.1.1 Correlation ratio general

The correlation ratio,  $R$ , shall be used to correct for any bias between the upstream and downstream sampling systems. The correlation ratio shall be established from the ratio of downstream to upstream particle counts with the aerosol generator on, but without any test device installed in the test rig. The correlation ratio shall be determined for each test device and at the air flow rate of the test device. To measure the correlation ratio, follow the sampling requirements of [9.3.1](#) without installing a test device.

The general formula for correlation ratio is:

$$R = \frac{\text{downstream}}{\text{upstream}} \quad (12)$$

where

*downstream* is the particle count at the downstream sample probe;

*upstream* is the particle count at the upstream sample probe.

#### 10.1.2 Correlation ratio data reduction

The correlation ratio shall be calculated for each upstream and downstream sample in each particle size range using the upstream and downstream values.

$$R_{i,ps} = \frac{D_{c,i,ps}}{U_{c,i,ps}} \quad (13)$$

where

$R_{i,ps}$  is the correlation ratio for sample,  $i$ , and for particle size,  $ps$ ;

$D_{c,i,ps}$  is the downstream correlation count for sample,  $i$ , and for particle size  $ps$ ;

$U_{c,i,ps}$  is the upstream correlation count for sample,  $i$ , and for particle size  $ps$ .

These correlation ratios shall be averaged to determine a final correlation ratio value for each particle size.

$$\bar{R}_{ps} = \frac{\sum_{i=1}^n R_{i,ps}}{n} \quad (14)$$

where

$\bar{R}_{ps}$  is the correlation ratio for particle size,  $ps$ ;

$R_{i,ps}$  is the correlation ratio for sample,  $i$ , and for particle size,  $ps$ ;

$n$  number of samples

The standard deviation of the correlation ratio shall be determined by:

$$\delta_{c,ps} = \sqrt{\frac{\sum_{i=1}^n (R_{i,ps} - \bar{R}_{ps})^2}{n-1}} \quad (15)$$

where

- $\delta_{c,ps}$  is the standard deviation of the correlation ratio for particle size  $ps$ ;
- $\bar{R}_{ps}$  is the correlation ratio for particle size  $ps$ ;
- $R_{i,ps}$  is the correlation ratio for sample  $i$  and for particle size  $ps$ ;

The 95 % uncertainty of the correlation value shall be determined by:

$$e_{c,ps} = \delta_{c,ps} \times \frac{st}{\sqrt{n}} \quad (16)$$

where

- $e_{c,ps}$  is the correlation uncertainty for particle size,  $ps$ ;
- $\delta_{c,ps}$  is the standard deviation of the correlation ratio for particle size,  $ps$ ;
- $st$  is the  $t$  distribution variable from [Table 7](#) for a given value of  $n$ ;
- $n$  is the number of samples.

NOTE The values of  $t$  distribution are calculated according to the probabilities of two alpha values and the degrees of freedom. The  $t$  distribution table (two tailed) for a 95 % confidence level is shown.

The 95 % confidence limits of the correlation value shall be determined by:

$$\bar{R}_{lcl,ps} = \bar{R}_{ps} - e_{c,ps} \quad (17)$$

$$\bar{R}_{ucl,ps} = \bar{R}_{ps} + e_{c,ps} \quad (18)$$

where

- $\bar{R}_{lcl,ps}$  is the lower confidence limit of the correlation ratio for particle size,  $ps$ ;
- $\bar{R}_{ucl,ps}$  is the upper confidence limit of the correlation ratio for particle size,  $ps$ ;
- $e_{c,ps}$  is the correlation uncertainty for particle size,  $ps$ .

**Table 7 — Student's  $t$  distribution variable**

Number of samples $n$	Number of degrees of freedom $\nu = n - 1$	$st$
5	4	2,776
10	9	2,262
15	14	2,145

**Table 7 (continued)**

Number of samples <i>n</i>	Number of degrees of freedom <i>v = n - 1</i>	<i>st</i>
20	19	2,093
25	24	2,064
30	29	2,045

The sum of the particles sampled during the correlation counts shall be calculated.

$$U_{c,tot,ps} = \sum_{i=1}^n U_{c,i,ps} \tag{19}$$

where

*U<sub>c,tot,ps</sub>* is the sum of the particles sampled during correlation for particle size, *ps*;

*U<sub>c,i,ps</sub>* is the correlation particles sampled for sample, *i*, and for particle size, *ps*.

## 10.2 Penetration and fractional efficiency

### 10.2.1 Penetration and fractional efficiency general

The fractional efficiency is a measure of the fraction of particles that the test device removes from the air that passes through it and is calculated from the amount of particulate that penetrates the test device during the test. The general formulas for penetration (*P*) and fractional efficiency (*E<sub>ps</sub>*) are shown below.

$$P = \frac{\text{downstream}}{\text{upstream}} \tag{20}$$

$$E_{ps} = (1 - P_{ps}) \times 100 \tag{21}$$

where

*downstream* is the particle count downstream of the test device;

*upstream* is the particle count upstream of the test device;

*E<sub>ps</sub>* is the particle fractional efficiency at particle size, *ps*, %;

*P<sub>ps</sub>* is the particle penetration at particle size, *ps*.

### 10.2.2 Penetration data reduction

The observed penetration shall be calculated for each upstream and downstream sample in each particle size range using the upstream and downstream values.

$$P_{i,o,ps} = \frac{D_{i,ps}}{U_{i,ps}} \tag{22}$$



where

$P_{i,o,ps}$  is the observed penetration for sample  $i$  and for particle size,  $ps$ ;

$D_{i,ps}$  is the downstream particle count for sample,  $i$ , and for particle size,  $ps$ ;

$U_{i,ps}$  is the upstream particle count for sample,  $i$ , and for particle size,  $ps$ .

These penetrations shall be averaged to determine the observed penetration value for each particle size.

$$\bar{P}_{o,ps} = \frac{\sum_{i=1}^n P_{i,o,ps}}{n} \quad (23)$$

where

$\bar{P}_{o,ps}$  is the observed penetration for particle size,  $ps$ ;

$P_{i,o,ps}$  is the observed penetration for sample,  $i$ , and for particle size,  $ps$ .

The standard deviation of the observed penetrations shall be determined by:

$$\delta_{o,ps} = \sqrt{\frac{\sum_{i=1}^n (P_{i,o,ps} - \bar{P}_{o,ps})^2}{n-1}} \quad (24)$$

where

$\delta_{o,ps}$  is the standard deviation of the observed penetration for particle size,  $ps$ ;

$\bar{P}_{o,ps}$  is the observed penetration for particle size,  $ps$ ;

$P_{i,o,ps}$  is the observed penetration for sample,  $i$ , and for particle size,  $ps$ .

The observed penetrations shall be corrected by the correlation ratio to give the final penetration values for each particle size.

$$\bar{P}_{ps} = \frac{\bar{P}_{o,ps}}{R_{ps}} \quad (25)$$

where

$\bar{P}_{ps}$  is the final penetration for particle size,  $ps$ ;

$\bar{P}_{o,ps}$  is the observed penetration for particle size,  $ps$ ;

$\bar{R}_{ps}$  is the final correlation ratio for particle size,  $ps$ .

The standard deviation of the correlation ratio shall be combined with the standard deviation of the observed penetration to determine the total error.

$$\delta_{ps} = \bar{P}_{ps} \cdot \sqrt{\left(\frac{\delta_{c,ps}}{\bar{R}_{ps}}\right)^2 + \left(\frac{\delta_{o,ps}}{\bar{P}_{o,ps}}\right)^2} \quad (26)$$

where

- $\delta_{ps}$  is the standard deviation of the observed penetration for particle size,  $ps$ ;
- $\bar{P}_{ps}$  is the final penetration for particle size,  $ps$ ;
- $\delta_{c,ps}$  is the standard deviation of the correlation ratio for particle size,  $ps$ ;
- $\bar{R}_{ps}$  is the final correlation ratio for particle size,  $ps$ ;
- $\delta_{o,ps}$  is the standard deviation of the observed penetration for particle size,  $ps$ ;
- $\bar{P}_{o,ps}$  is the observed penetration for particle size,  $ps$ .

The 95 % uncertainty of the penetration value shall be determined by:

$$e_{ps} = \delta_{ps} \times \frac{st}{\sqrt{n}} \quad (27)$$

where

- $e_{ps}$  is the penetration uncertainty for particle size,  $ps$ ;
- $\delta_{ps}$  is the standard deviation of the penetration for particle size,  $ps$ ;
- $st$  is the  $t$  distribution variable from [Table 7](#) for a give value of  $n$ ;
- $n$  is the number of samples.

The 95 % confidence limits of the penetration shall be determined by:

$$\bar{P}_{lcl,ps} = \bar{P}_{ps} - e_{ps} \quad (28)$$

$$\bar{P}_{ucl,ps} = \bar{P}_{ps} + e_{ps} \quad (29)$$

where

- $e_{ps}$  is the penetration uncertainty for particle size,  $ps$ ;
- $\bar{P}_{lcl,ps}$  is the lower confidence limit of the penetration for particle size,  $ps$ ;
- $\bar{P}_{ucl,ps}$  is the upper confidence limit of the penetration for particle size,  $ps$ .

The sum of the upstream particle counts for particle size,  $ps$ , shall be calculated.

$$U_{tot,ps} = \sum_{i=1}^n U_{i,ps} \quad (30)$$

where

- $U_{tot,ps}$  is the sum of the upstream particle counts for particle size,  $ps$ ;
- $U_{i,ps}$  is the efficiency particles sampled for sample,  $i$ , and for particle size,  $ps$ .

### 10.3 Data quality requirements

#### 10.3.1 Correlation background counts

The correlation background count values for each particle size shall be less than 5 % of the average upstream particle measured during the correlation testing.

$$D_{B,c,ps} \text{ or } U_{B,c,ps} < \frac{\sum_{i=1}^n U_{c,i,ps}}{n} \times 0,05 \quad (31)$$

where

$U_{B,c,ps}$  is the upstream background average correlation count for particle size,  $ps$ ;

$D_{B,c,ps}$  is the downstream background average correlation count for particle size,  $ps$ ;

$U_{c,i,ps}$  is the upstream average correlation count for particle size,  $ps$ .

#### 10.3.2 Efficiency background counts

The efficiency background count values for each particle size shall be less than 5 % of the average upstream particle measured during the correlation testing.

$$D_{B,ps} \text{ or } U_{B,ps} < \frac{\sum_{i=1}^n U_{i,ps}}{n} \times 0,05 \quad (32)$$

where

$U_{B,ps}$  is the upstream background average efficiency count for particle size,  $ps$ ;

$D_{B,ps}$  is the downstream background average efficiency count for particle size,  $ps$ ;

$U_{i,ps}$  is the upstream average efficiency count for particle size,  $ps$ .

#### 10.3.3 Correlation ratio

The correlation ratios and uncertainty shall fall within the limits shown in [Table 3](#) and repeated below in [Table 8](#). The minimum number of counts from [Formula \(19\)](#) for each particle size shall be greater than or equal to 500. If a sufficient number of counts is not obtained, the sample time or aerosol concentration shall be increased. The aerosol concentration shall not exceed the concentration limit of the OPC(s). The correlation uncertainty ( $e_{c,ps}$ ) is calculated from [Formula \(16\)](#).

**Table 8 — Correlation ratio limits**

Size range	Particle size range, $\mu\text{m}$	Total count minimum	Correlation ratio value limits	$e_{c,ps}$
1	0,30 – 0,40	$U_{c,tot,1} \geq 500$	0,90 to 1,10	$e_{c,1} \leq 0,05$
2	0,40 – 0,55	$U_{c,tot,2} \geq 500$	0,90 to 1,10	$e_{c,2} \leq 0,05$
3	0,55 – 0,70	$U_{c,tot,3} \geq 500$	0,90 to 1,10	$e_{c,3} \leq 0,05$
4	0,70 – 1,00	$U_{c,tot,4} \geq 500$	0,90 to 1,10	$e_{c,4} \leq 0,05$
5	1,00 – 1,30	$U_{c,tot,5} \geq 500$	0,80 to 1,20	$e_{c,5} \leq 0,05$
6	1,30 – 1,60	$U_{c,tot,6} \geq 500$	0,80 to 1,20	$e_{c,6} \leq 0,05$
7	1,60 – 2,20	$U_{c,tot,7} \geq 500$	0,80 to 1,20	$e_{c,7} \leq 0,05$
8	2,20 – 3,00	$U_{c,tot,8} \geq 500$	0,80 to 1,20	$e_{c,8} \leq 0,05$

**Table 8 (continued)**

Size range	Particle size range, $\mu\text{m}$	Total count minimum	Correlation ratio value limits	$e_{c,ps}$
9	3,00 – 4,00	$U_{c,tot,9} \geq 500$	0,70 to 1,30	$e_{c,9} \leq 0,10$
10	4,00 – 5,50	$U_{c,tot,10} \geq 500$	0,70 to 1,30	$e_{c,10} \leq 0,10$
11	5,50 – 7,00	$U_{c,tot,11} \geq 500$	0,70 to 1,30	$e_{c,11} \leq 0,15$
12	7,00 – 10,0	$U_{c,tot,12} \geq 500$	0,70 to 1,30	$e_{c,12} \leq 0,15$

**10.3.4 Penetration**

The penetration uncertainty shall fall within the limits shown in [Table 9](#).

The minimum number of counts from [Formula \(30\)](#) for each particle size shall be greater than or equal to 500. If a sufficient number of counts is not obtained, the sample time or aerosol concentration shall be increased. The aerosol concentration shall not exceed the concentration limit of the OPC(s).

The penetration uncertainty ( $e_{ps}$ ) is calculated from [Formula \(27\)](#) and shall be less than or equal to the greater of the static limit or the dynamic limit shown for that particle size in [Table 9](#).

If the penetration uncertainty cannot meet this data requirement, the penetration upper confidence limit ( $P_{ucl,ps}$ ) shall be used for that particle size penetration.

**Table 9 — Penetration limits**

Size range	Particle size range, $\mu\text{m}$	Total count minimum	Static uncertainty	Dynamic uncertainty
1	0,30 – 0,40	$U_{tot,1} \geq 500$	$e_1 \leq 0,05$	$e_1 \leq (0,07 \cdot \bar{P}_1)$
2	0,40 – 0,55	$U_{tot,2} \geq 500$	$e_2 \leq 0,05$	$e_2 \leq (0,07 \cdot \bar{P}_2)$
3	0,55 – 0,70	$U_{tot,3} \geq 500$	$e_3 \leq 0,05$	$e_3 \leq (0,07 \cdot \bar{P}_3)$
4	0,70 – 1,00	$U_{tot,4} \geq 500$	$e_4 \leq 0,05$	$e_4 \leq (0,07 \cdot \bar{P}_4)$
5	1,00 – 1,30	$U_{tot,5} \geq 500$	$e_5 \leq 0,05$	$e_5 \leq (0,07 \cdot \bar{P}_5)$
6	1,30 – 1,60	$U_{tot,6} \geq 500$	$e_6 \leq 0,05$	$e_6 \leq (0,07 \cdot \bar{P}_6)$
7	1,60 – 2,20	$U_{tot,7} \geq 500$	$e_7 \leq 0,05$	$e_7 \leq (0,07 \cdot \bar{P}_7)$
8	2,20 – 3,00	$U_{tot,8} \geq 500$	$e_8 \leq 0,05$	$e_8 \leq (0,07 \cdot \bar{P}_8)$
9	3,00 – 4,00	$U_{tot,9} \geq 500$	$e_9 \leq 0,05$	$e_9 \leq (0,15 \cdot \bar{P}_9)$
10	4,00 – 5,50	$U_{tot,10} \geq 500$	$e_{10} \leq 0,05$	$e_{10} \leq (0,15 \cdot \bar{P}_{10})$
11	5,50 – 7,00	$U_{tot,11} \geq 500$	$e_{11} \leq 0,05$	$e_{11} \leq (0,20 \cdot \bar{P}_{11})$
12	7,00 – 10,0	$U_{tot,12} \geq 500$	$e_{12} \leq 0,05$	$e_{12} \leq (0,20 \cdot \bar{P}_{12})$

**10.4 Fractional efficiency calculation**

The fractional efficiency is determined by one of the following formulae.

For all particle sizes that meet all of the data quality requirements, the fractional efficiency for the particle size(s) is determined by:

$$E_{ps} = (1 - \bar{P}_{ps}) \times 100 \quad (33)$$

where

$E_{ps}$  is the fractional efficiency particle size,  $ps$ , %;

$\bar{P}_{ps}$  is the penetration for particle size,  $ps$ .

For any particle sizes that cannot meet all of the data quality requirements, the fractional efficiency for the particle size(s) that cannot meet the data quality requirement is determined by:

$$E_{ps} = (1 - \bar{P}_{ucl,ps}) \times 100 \quad (34)$$

where

$E_{ps}$  is the fractional efficiency particle size,  $ps$ , %;

$\bar{P}_{ucl,ps}$  is the upper confidence limit of the penetration for particle size,  $ps$ .

## 11 Reporting results

### 11.1 General

Test results shall be reported using the test report format shown in this part of ISO 16890. [Figure 11](#) and [Figure 12](#) comprise the complete test report, and are examples of acceptable forms. Use of this exact format is not required, but the report shall include all of the items shown in [11.2](#).

### 11.2 Required reporting elements

#### 11.2.1 Report general

Every test report shall include the information listed in [11.2](#). Any report not containing all required elements shall be considered invalid.

#### 11.2.2 Report values

All data values for particle removal efficiency shall be reported as whole number values only (no decimal or fractions).

Data values for resistance to airflow shall be reported as whole number values only (no decimal or fractions) when displayed in SI units (Pa) or to 2 decimal places in IP units (in H<sub>2</sub>O).

#### 11.2.3 Report summary

The one-page summary section of the performance report (see [Figure 11](#)) shall include the following information:

- a) laboratory information:
  - 1) laboratory name;
  - 2) laboratory location and contact information;

## ISO 16890-2:2016(E)

- 3) test operator's name(s);
  - 4) particle counting and sizing device(s) information;
    - i) manufacturer's name;
    - ii) model number;
    - iii) coincidence value ( $p/m^3$ ) ( $p/ft^3$ ).
  - 5) method of airflow measurement.
- b) test information:
- 1) an identification of this part of ISO 16890;
  - 2) unique test report identification;
  - 3) date of the test;
  - 4) how the sample was obtained.
- c) test device information:
- 1) manufacturer's name (or name of the marketing organization, if different from the manufacturer);
  - 2) brand and model number as marked on the test device;
  - 3) test device condition (e.g. clean, conditioned as per ISO 16890-4, loaded as per ISO 16890-3, used, etc.);
  - 4) dimensions (height, width, and depth);
  - 5) physical description of construction (e.g. pocket filter, number of pockets; pleated panel, number and depth of pleats);
  - 6) media description including:
    - i) type of media with description and identification (e.g. glass fibre AB12, inorganic fibre 12AB);
    - ii) media colour;
    - iii) effective filter area;
    - iv) type and amount of any additive to the media. If this information is unknown, it shall be shown as "Not Available";
    - v) electrostatic charge. If this information is unknown, it shall be shown as "Not Available".
  - 7) a photo of the actual test device is highly recommended, but not required;
  - 8) any other pertinent descriptive attributes.
- d) test device literature data or operating data as stated by the manufacturer:
- 1) test device initial resistance to airflow at the test airflow rate;
  - 2) rated final resistance to airflow at the test airflow rate;
  - 3) initial particle removal efficiency;

- 4) any other literature data available or furnished operating data.
- e) test conditions:
  - 1) test airflow rate;
  - 2) test air temperature and relative humidity;
  - 3) test aerosol used.
- f) test data:
  - 1) resistance to airflow data at the test airflow rate;
  - 2) fractional efficiency in each measured particle size range;
  - 3) total upstream concentration measured during testing ( $p/m^3$ ) by size range.

#### 11.2.4 Report details

The report details shall include, but are not limited to the following information:

- a) Measured results
  - 1) The resistance to airflow data at each of the required airflow rates shall be reported in table format and as a graph of airflow vs. resistance to airflow.
    - i) The reported resistance to airflow shall be corrected to an air density of  $1,20 \text{ kg/m}^3$ . However, if the test air density is between  $1,16 \text{ kg/m}^3$  ( $0,072 \text{ lb/ft}^3$ ) and  $1,24 \text{ kg/m}^3$  ( $0,077 \text{ lb/ft}^3$ ), no corrections need to be made. The corrections are described in [Annex B](#).
  - 2) The results of the particle removal efficiency measurement shall be reported both in table (summary page) and graphical format.
- b) Concluding statement
  - 1) The results of this test relate only to the test device in the condition stated herein. The performance results cannot by themselves be quantitatively applied to predict filtration performance in all “real life” environments.

ISO 16890-2:20xx - AIR FILTER TEST RESULT SUMMARY					Testing Organization	
					Name	
					Address	
					Phone	
<b>GENERAL</b>						
Test ID:		Date of test:		Operator:		
Particle Counter Information			Airflow measurement:	Test sample obtained:		
Manufacturer:	Model:	Coincidence Value (p/m <sup>3</sup> ):				
<b>DEVICE TESTED</b>						
Model:		Manufacturer:		Filter dimensions (W x H x D) (mm):		
Type of media:		Net effective media area (m <sup>2</sup> ):		Construction: (# pleats, pockets, etc.)		
Filter/media electrostatic charge:		Media colour:		Media adhesive:		
Device Condition: <i>(clean/initial, used, conditioned per ISO 16890-4, dust loaded per ISO 16890-3, etc.) (If dust loaded, include dust type)</i>						
Other descriptive information:						
<b>TEST DATA SUMMARY</b>						
Test air flow rate (m <sup>3</sup> /s):	Test air temperature (°C):	Test air RH (%):	Test aerosol:	Loading dust or Conditioning method:		
<b>RESULTS</b>						
Resistance to airflow (Pa)			Fractional Efficiency (%)			
Measured:	Rated Initial:	Range (µm)	Measured Efficiency	Rated Efficiency	Upstream Concentration (p/m <sup>3</sup> )	
	Rated Final:	0,30 – 0,40				
Test Device Photo		0,40 – 0,55				
		0,55 – 0,70				
		0,70 – 1,00				
		1,00 – 1,30				
		1,30 – 1,60				
		1,60 – 2,20				
		2,20 – 3,00				
		3,00 – 4,00				
		4,00 – 5,50				
		5,50 – 7,00				
		7,00 – 10,0				
<b>Remarks:</b>						
NOTE The results of this test relate only to the test device in the condition stated herein. The performance results cannot by themselves be quantitatively applied to predict filtration performance in all "real life" environments.						

Figure 11 — Test report summary page format



ISO 16890-2:20xx - AIR FILTER TEST RESULT DETAILS			Testing Organization
		Name	
		Address	
		Phone	
Test ID:	Date of test:	Operator:	
TEST DATA DETAILS			
Resistance to air flow			
% of rated airflow	Air flow rate (m <sup>3</sup> /s)	Resistance to air flow (Pa)	
50 %			
75 %			
100 %			
125 %			
			Air flow rate (m <sup>3</sup> /s)
Fractional Efficiency by Particle Size			
<p><b>NOTE</b> The results of this test relate only to the test device in the condition stated herein. The performance results cannot by themselves be quantitatively applied to predict filtration performance in all "real life" environments.</p>			

Figure 12 — Test report details page format

## Annex A (informative)

### Example

In this example test data, dual OPCs were used to test the filter element. Prior to the test device installation, a correlation ratio was determined by following the efficiency procedures with no test device installed. The aerosol sampling followed the procedures for dual OPC testing. Each particle count was a 30 s sample time. The initial (before correlation testing) and final (after correlation testing) backgrounds counts are shown in [Table A.1](#) with the particle counter channel sizes.

**Table A.1 — Initial and final backgrounds counts**

<i>i</i>	$d_i$	$d_{i+1}$	$d_i$	$U_{B,c,b}$	$U_{B,c,f}$	$U_{B,c}$	$D_{B,c,b}$	$D_{B,c,f}$	$D_{B,c}$
	µm	µm	µm						
1	0,3	0,4	0,35	7	3	5	4	2	3
2	0,4	0,55	0,47	5	1	3	3	1	2
3	0,55	0,7	0,62	3	1	2	1	1	1
4	0,7	1,0	0,84	2	0	1	0	0	0
5	1,0	1,3	1,14	0	0	0	0	0	0
6	1,3	1,6	1,44	0	0	0	0	0	0
7	1,6	2,2	1,88	0	0	0	0	0	0
8	2,2	3,0	2,57	0	0	0	0	0	0
9	3,0	4,0	3,46	0	0	0	0	0	0
10	4,0	5,5	4,69	0	0	0	0	0	0
11	5,5	7,0	6,20	0	0	0	0	0	0
12	7,0	10,0	8,37	0	0	0	0	0	0

NOTE All count data shown is the number of particles counted for 30 seconds.

The KCl aerosol generator was turned on and allowed to stabilize for the proper time as per the test rig qualification procedures. The correlation ratio data are shown in [Table A.2](#), [Table A.3](#) and [Table A.4](#).

**Table A.2 — Correlation upstream count data**

<i>i</i>	$d_i$	Upstream correlation data					$U_{c,tot}$
	µm	1	2	3	4	5	
1	0,35	25 666	27 892	28 902	29 872	25 251	137 583
2	0,47	22 787	22 333	22 875	22 654	22 565	113 214
3	0,62	18 789	18 653	18 777	18 043	19 811	94 073
4	0,84	13 001	12 678	12 879	12 098	12 344	63 000
5	1,14	8 766	8 899	8 722	8 344	8 888	43 619
6	1,44	6 654	6 786	6 732	6 587	6 333	33 092
7	1,88	3 567	3 777	3 333	3 422	3 677	17 776
8	2,57	1 123	1 277	1 111	1 098	1 122	5 731
9	3,46	927	999	878	821	900	4 525

NOTE All count data shown is the number of particles counted for 30 seconds.

Table A.2 (continued)

<i>i</i>	<i>d<sub>i</sub></i>	Upstream correlation data					
	µm	1	2	3	4	5	<i>U<sub>c,tot</sub></i>
10	4,69	676	846	721	777	699	3 719
11	6,20	345	371	401	271	333	1 721
12	8,37	221	231	226	241	222	1 141

NOTE All count data shown is the number of particles counted for 30 seconds.

Table A.3 — Correlation downstream count data

<i>i</i>	<i>d<sub>i</sub></i>	Downstream correlation data					
	µm	1	2	3	4	5	Tot
1	0,35	26 571	28 787	28 762	30 902	26 521	141 543
2	0,47	23 000	23 111	23 198	23 098	23 089	115 496
3	0,62	18 989	18 711	17 987	18 021	19 888	93 596
4	0,84	12 987	12 076	12 699	12 009	12 111	61 882
5	1,14	8 512	8 431	8 399	8 340	8 555	42 237
6	1,44	6 167	6 044	5 982	6 161	5 998	30 352
7	1,88	3 233	3 434	3 285	3 167	3 422	16 541
8	2,57	1 222	1 333	1 222	1 188	1 184	6 149
9	3,46	972	1 044	921	867	948	4 752
10	4,69	757	898	787	843	727	4 012
11	6,20	377	404	411	302	366	1 860
12	8,37	234	234	236	251	231	1 186

NOTE All count data shown is the number of particles counted for 30 seconds.

Table A.4 — Correlation calculation data

<i>i</i>	<i>d<sub>i</sub></i>	Correlation ratios							
	µm	<i>R</i> <sub>1</sub>	<i>R</i> <sub>2</sub>	<i>R</i> <sub>3</sub>	<i>R</i> <sub>4</sub>	<i>R</i> <sub>5</sub>	<i>R</i> <sub>avg</sub>	δ <sub>0</sub>	<i>e<sub>c</sub></i>
1	0,35	1,035	1,032	0,995	1,034	1,050	1,029	0,020	0,025
2	0,47	1,009	1,035	1,014	1,020	1,023	1,020	0,010	0,012
3	0,62	1,011	1,003	0,958	0,999	1,004	0,995	0,021	0,026
4	0,84	0,999	0,953	0,986	0,993	0,981	0,982	0,018	0,022
5	1,14	0,971	0,947	0,963	1,000	0,963	0,969	0,019	0,024
6	1,44	0,927	0,891	0,889	0,935	0,947	0,918	0,027	0,033
7	1,88	0,906	0,909	0,986	0,925	0,931	0,931	0,032	0,040
8	2,57	1,088	1,044	1,100	1,082	1,055	1,074	0,023	0,029
9	3,46	1,049	1,045	1,049	1,056	1,053	1,050	0,004	0,005
10	4,69	1,120	1,061	1,092	1,085	1,040	1,080	0,030	0,038
11	6,20	1,093	1,089	1,025	1,114	1,099	1,084	0,034	0,043
12	8,37	1,059	1,013	1,044	1,041	1,041	1,040	0,017	0,021

NOTE All count data shown is the number of particles counted for 30 seconds.

All of the correlation ratios meet the data requirements from [Table 8](#).

The test device was installed into the test rig and the resistance to airflow measured at 50 %, 75 %, 100 % and 125 % of the test air flow rate. The data are shown in the test report in [Figure A.1](#) and

Figure A.2. Next, the dual OPC test sequence was followed for the efficiency counts. The background counts with the aerosol generator turned off are shown in Table A.5.

**Table A.5 — Background counts with the aerosol generator turned off**

<i>i</i>	<i>d<sub>i</sub></i>	<i>U<sub>B,b</sub></i>	<i>U<sub>B,f</sub></i>	<i>U<sub>B</sub></i>	<i>D<sub>B,b</sub></i>	<i>D<sub>B,f</sub></i>	<i>D<sub>B</sub></i>
	μm						
1	0,35	1	3	2	2	2	2
2	0,47	3	1	2	1	1	1
3	0,62	1	1	1	1	1	1
4	0,84	0	0	1	0	0	0
5	1,14	0	0	0	0	0	0
6	1,44	0	0	0	0	0	0
7	1,88	0	0	0	0	0	0
8	2,57	0	0	0	0	0	0
9	3,46	0	0	0	0	0	0
10	4,69	0	0	0	0	0	0
11	6,20	0	0	0	0	0	0
12	8,37	0	0	0	0	0	0

NOTE All count data shown is the number of particles counted for 30 seconds.

The KCl aerosol generator was turned on and allowed to stabilize for the proper time as per the test rig qualification procedures. The efficiency count data are shown in Table A.6, Table A.7, and Table A.8.

**Table A.6 — Upstream count data**

<i>i</i>	<i>d<sub>i</sub></i>	Upstream efficiency data					
	μm	1	2	3	4	5	<i>U<sub>C,tot</sub></i>
1	0,35	28 387	28 071	29 755	28 788	28 501	143 502
2	0,47	22 871	22 244	22 914	22 276	22 668	112 973
3	0,62	18 927	18 476	18 677	18 596	18 402	93 078
4	0,84	13 015	12 480	12 610	11 661	12 520	63 286
5	1,14	8 783	8 857	8 793	8 643	8 703	43 779
6	1,44	6 974	6 802	6 837	6 860	6 899	34 372
7	1,88	3 600	3 724	3 434	3 575	3 675	18 008
8	2,57	1 088	1 084	1 065	1 067	1 116	5 420
9	3,46	834	830	833	840	831	4 168
10	4,69	691	714	709	680	693	3 487
11	6,20	334	347	343	331	328	1 683
12	8,37	220	231	237	228	231	1147

NOTE All count data shown is the number of particles counted for 30 seconds.

**Table A.7 — Downstream count data**

<i>i</i>	<i>d<sub>i</sub></i>	Downstream efficiency data					
	µm	1	2	3	4	5	Tot
1	0,35	10 045	10 022	10 001	10 055	10 067	50 190
2	0,47	6 407	6 401	6 396	6 399	6 398	32 001
3	0,62	4 039	4 056	4 033	4 027	4 087	20 242
4	0,84	1 722	1 701	1 731	1 711	1 729	8 594
5	1,14	651	673	698	675	682	3 379
6	1,44	303	316	311	309	313	1 552
7	1,88	101	100	103	104	99	507
8	2,57	21	20	19	21	22	103
9	3,46	1	2	0	0	2	5
10	4,69	0	0	1	0	0	1
11	6,20	0	0	0	0	0	0
12	8,37	0	0	0	0	0	0

NOTE All count data shown is the number of particles counted for 30 seconds.

**Table A.8 — Penetration calculation**

<i>i</i>	<i>d<sub>i</sub></i>	Correlation ratios							
	µm	<i>P</i> <sub>1</sub>	<i>P</i> <sub>2</sub>	<i>P</i> <sub>3</sub>	<i>P</i> <sub>4</sub>	<i>P</i> <sub>5</sub>	$\bar{P}_0$	$\delta_0$	$\bar{P}$
1	0,35	0,354	0,357	0,336	0,349	0,353	0,350	0,008	0,340
2	0,47	0,280	0,288	0,279	0,287	0,282	0,283	0,004	0,278
3	0,62	0,213	0,220	0,216	0,217	0,222	0,218	0,003	0,219
4	0,84	0,132	0,136	0,137	0,147	0,138	0,138	0,005	0,141
5	1,14	0,074	0,076	0,079	0,078	0,078	0,077	0,002	0,080
6	1,44	0,043	0,046	0,045	0,045	0,045	0,045	0,001	0,049
7	1,88	0,028	0,027	0,030	0,029	0,027	0,028	0,001	0,030
8	2,57	0,019	0,018	0,018	0,020	0,020	0,019	0,001	0,018
9	3,46	0,001	0,002	0,000	0,000	0,002	0,001	0,001	0,001
10	4,69	0,000	0,000	0,001	0,000	0,000	0,000	0,001	0,000
11	6,20	0,000	0,000	0,000	0,000	0,000	0,000	0,000	0,000
12	8,37	0,000	0,000	0,000	0,000	0,000	0,000	0,000	0,000

The uncertainty is determined by combining the standard deviations for the correlation and the penetration data as reported in [Table A.9](#).

**Table A.9 — Uncertainty**

<i>i</i>	<i>d<sub>i</sub></i>	Penetration data reduction			Static uncertainty	Dynamic uncertainty		<i>e</i>
	µm	$\bar{P}$	$\delta$	<i>e</i>	<i>e<sub>ps</sub></i> ≤ 0,05	Limit	Pass/fail	
1	0,35	0,340	0,010	0,013	Pass	0,024	Pass	66
2	0,47	0,278	0,005	0,006	Pass	0,019	Pass	72
3	0,62	0,219	0,006	0,007	Pass	0,015	Pass	78
4	0,84	0,141	0,006	0,007	Pass	0,010	Pass	86
5	1,14	0,080	0,003	0,003	Pass	0,006	Pass	92

**Table A.9** (continued)

<i>i</i>	<i>d<sub>i</sub></i>	Penetration data reduction			Static uncertainty	Dynamic uncertainty		<i>e</i>
	μm	$\bar{p}$	$\delta$	<i>e</i>	$e_{ps} \leq 0,05$	Limit	Pass/fail	
6	1,44	0,049	0,002	0,002	Pass	0,003	Pass	95
7	1,88	0,030	0,002	0,002	Pass	0,002	Pass	97
8	2,57	0,018	0,001	0,001	Pass	0,001	Pass	98
9	3,46	0,001	0,001	0,001	Pass	0,000	Pass	100
10	4,69	0,000	0,001	0,001	Pass	0,000	Pass	100
11	6,20	0,000	0,000	0,000	Pass	0,000	Pass	100
12	8,37	0,000	0,000	0,000	Pass	0,000	Pass	100

With this data set completed, the final test report would be shown as follows:

ISO 16890-2:201x - AIR FILTER TEST RESULT SUMMARY				Testing Organization	
				Name <i>Any Filter Test Lab</i>	
				Address <i>1234 High St, Anywhere</i>	
				Phone <i>(123) 456-7890</i>	
<b>GENERAL</b>					
Test ID: <i>Unique Test Number</i>		Date of test: <i>4 July 201x</i>		Operator: <i>Bill Filtergeek</i>	
Particle Counter Information			Airflow measurement:		Test sample obtained:
Manufacturer: <i>ABC</i>	Model: <i>1234</i>	Coincidence Value (p/m <sup>3</sup> ): <i>71M</i>	<i>XYX 23</i>		<i>Open Market</i>
<b>DEVICE TESTED</b>					
Model: <i>Bagenstein</i>		Manufacturer: <i>Acme Filter</i>		Filter dimensions (W x H x D) (mm): <i>610 x 610 x 610</i>	
Type of media: <i>Material</i>		Net effective media area (m <sup>2</sup> ): <i>5,9</i>		Construction: <i>8 pockets</i>	
Filter/media electrostatic charge: <i>None</i>		Media colour: <i>Yellow</i>		Media adhesive: <i>None</i>	
Device Condition: <i>(clean/initial, used, conditioned per ISO 16890-4, dust loaded per ISO 16890-3, etc.) (If dust loaded, include dust type)</i> <i>Clean/Initial testing</i>					
Other descriptive information:					
<b>TEST DATA SUMMARY</b>					
Test air flow rate (m <sup>3</sup> /s): <i>0,944</i>	Test air temperature (°C): <i>23</i>	Test air RH (%): <i>47</i>	Test aerosol: <i>KCl</i>	Loading dust or Conditioning method: <i>N/A</i>	
<b>RESULTS</b>					
Resistance to airflow (Pa)			Fractional Efficiency		
Measured: <i>122</i>	<i>Initial Filter weight: 476 g</i>		Range (µm)	Measured Efficiency (%)	Upstream Concentration (number of particles per dm <sup>3</sup> )
			0,30 – 0,40	<i>66</i>	<i>57400</i>
Test Device Photo 			0,40 – 0,55	<i>72</i>	<i>45189</i>
			0,55 – 0,70	<i>78</i>	<i>37231</i>
			0,70 – 1,00	<i>86</i>	<i>25314</i>
			1,00 – 1,30	<i>92</i>	<i>17511</i>
			1,30 – 1,60	<i>95</i>	<i>13748</i>
			1,60 – 2,20	<i>97</i>	<i>7203,200</i>
			2,20 – 3,00	<i>98</i>	<i>2168,000</i>
			3,00 – 4,00	<i>100</i>	<i>1667,200</i>
			4,00 – 5,50	<i>100</i>	<i>1394,800</i>
			5,50 – 7,00	<i>100</i>	<i>673,200</i>
7,00 – 10,0	<i>100</i>	<i>458,800</i>			
<b>Remarks:</b>					
NOTE The results of this test relate only to the test device in the condition stated herein. The performance results cannot by themselves be quantitatively applied to predict filtration performance in all "real life" environments.					

Figure A.1 — Example of test report summary page

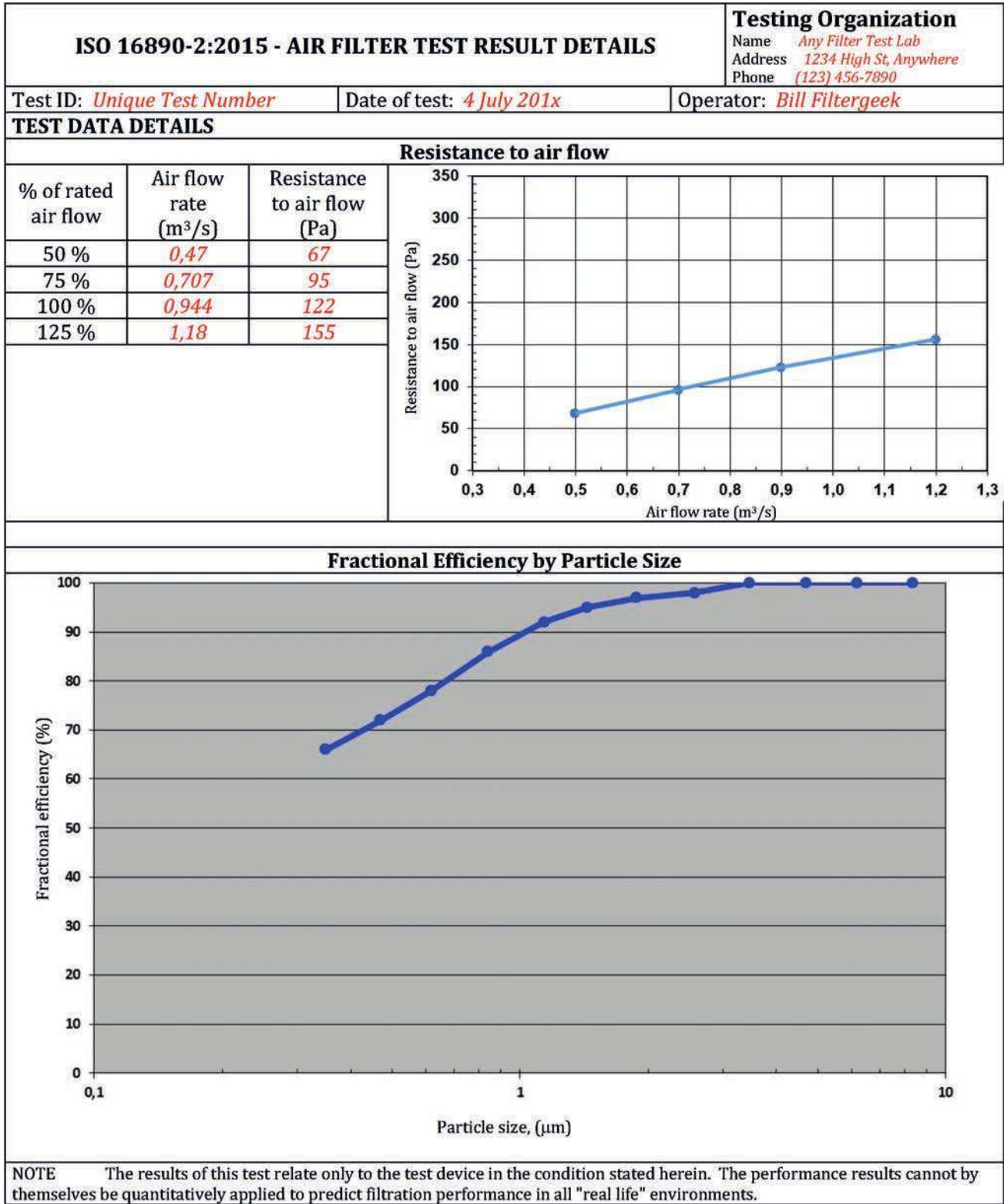

Figure A.2 — Example of test report details page



## Annex B (informative)

### Resistance to air flow calculation

All pressure losses measured during the test should be corrected to a reference air density of 1,20 (1,198 7) kg/m<sup>3</sup> (0,075 lb/ft<sup>3</sup>) which corresponds to standard air conditions: temperature 20 °C (68 °F), barometric pressure 101,325 kPa (14,7 lb/in<sup>2</sup>), relative humidity 50 %. However, as long as the air density is between 1,16 kg/m<sup>3</sup> (0,072 lb/ft<sup>3</sup>) and 1,24 kg/m<sup>3</sup> (0,077 lb/ft<sup>3</sup>), no corrections need to be made. All calculations are expressed in SI units only.

The pressure loss of a test device can be expressed as:

$$\Delta p = c(q_v)^n \quad (\text{B.1})$$

$$c = k \times \mu^{2-n} \times \rho^{n-1} \quad (\text{B.2})$$

where

$\Delta p$  is the pressure loss, Pa;

$k$  is a constant;

$q_v$  is the air flow rate, m<sup>3</sup>/s;

$\mu$  is the dynamic viscosity of air, Pa.s;

$n$  is an exponent;

$\rho$  is the air density, kg/m<sup>3</sup>.

The readings of the air flow measuring system shall be converted to the volumetric air flow rate at the conditions prevailing at the inlet of the test device. With these air flow rate values and the measured pressure losses, the exponent “ $n$ ” from [Formula \(B.1\)](#) could be determined by using at least a square technique.

With a known value of exponent “ $n$ ”, the measured pressure losses can be corrected to standard air conditions using Formula (B.3):

$$\Delta p_{1,20} = \Delta p \left( \frac{\mu_{1,20}}{\mu} \right)^{2-n} \times \left( \frac{\rho_{1,20}}{\rho} \right)^{n-1} \quad (\text{B.3})$$

where the unsubscripted quantities refer to the values at the test conditions and the subscripted quantities to values at the standard air conditions and

$\rho_{1,20}$  1,198 7 kg/m<sup>3</sup>;

$\mu_{1,20}$  18,097 × 10<sup>-6</sup> Pa.s.

The exponent “ $n$ ” is usually determined only for a clean test device. During the dust loading phase exponent “ $n$ ” can change. As it is undesirable to measure pressure loss curves after each dust loading phase, the initial value of exponent “ $n$ ” may be used during the device test. The air density  $\rho$  (kg/m<sup>3</sup>)

of temperature  $t$  (°C), barometric pressure  $p$  (Pa) and relative humidity  $\varphi$  (%) can be obtained by the [Formula \(B.4\)](#):

$$\rho = \frac{p - 0,378 p_w}{287,06(t + 273,15)} \quad (\text{B.4})$$

where  $p_w$  (Pa) is the partial vapour pressure of water in air given by [Formula \(B.5\)](#):

$$p_w = \frac{\varphi}{100} p_{ws} \quad (\text{B.5})$$

and  $p_{ws}$  (Pa) is the saturation vapour pressure of water in air at temperature  $t$  (°C) obtained from [Formula \(B.6\)](#):

$$p_{ws} = \exp \left[ 59,484\,085 - \frac{6\,790,498\,5}{t + 273,15} - 5,028\,02 \times \ln(t + 273,15) \right] \quad (\text{B.6})$$

The dynamic viscosity  $\mu$  (Pa.s) at a temperature  $t$  (°C) can be obtained from [Formula \(B.7\)](#):

$$\mu = \frac{1,455 \cdot 10^{-6} (t + 273,15)^{0,5}}{1 + 110,4 / (t + 273,15)} \quad (\text{B.7})$$

## Bibliography

- [1] ISO 2854, *Statistical interpretation of data — Techniques of estimation and tests relating to means and variances*
- [2] ISO 12103-1, *Road vehicles — Test contaminants for filter evaluation — Part 1: Arizona test dust*
- [3] ISO 14644-3, *Cleanrooms and associated controlled environments — Part 3: Test methods*
- [4] EN 779, *Particulate air filters for general ventilation — Determination of the filtration performance*
- [5] ASHRAE 52.2:2012, *Method of testing general ventilation air-cleaning devices for removal efficiency by particle size*
- [6] *Ginestet, A., Pugno, D., The fractional efficiency of air filters used in general ventilation, Journal of Aerosol Science, Vol 28, Supplement 1, September 1997 Pages S293-S294*
- [7] No JACA 37, *Guideline of Substitute Materials for DOP*
- [8] JIS Z 8901, *Test powders and test particles*
- [9] Hanley, James T. and Lawless, Phil A., *Particle Counter Specifications for use with Filter Performance Test Standard ANSI/ASHRAE/Standard 52.2, ASHRAE 1287-RP, June 15, 2010*
- [10] EU Council Directive 1999/30/EC of 22 April 1999
- [11] ASTM D1193, *Standard Specification for Reagent Water*

