

INTERNATIONAL STANDARD

ISO 16833

First edition
2006-02-15

Road vehicles — Wheels — Measurement of radial and lateral run-out

Véhicules routiers — Roues — Mesurage du faux-rond et du voile



Reference number
ISO 16833:2006(E)

© ISO 2006

PDF disclaimer

This PDF file may contain embedded typefaces. In accordance with Adobe's licensing policy, this file may be printed or viewed but shall not be edited unless the typefaces which are embedded are licensed to and installed on the computer performing the editing. In downloading this file, parties accept therein the responsibility of not infringing Adobe's licensing policy. The ISO Central Secretariat accepts no liability in this area.

Adobe is a trademark of Adobe Systems Incorporated.

Details of the software products used to create this PDF file can be found in the General Info relative to the file; the PDF-creation parameters were optimized for printing. Every care has been taken to ensure that the file is suitable for use by ISO member bodies. In the unlikely event that a problem relating to it is found, please inform the Central Secretariat at the address given below.

© ISO 2006

All rights reserved. Unless otherwise specified, no part of this publication may be reproduced or utilized in any form or by any means, electronic or mechanical, including photocopying and microfilm, without permission in writing from either ISO at the address below or ISO's member body in the country of the requester.

ISO copyright office
Case postale 56 • CH-1211 Geneva 20
Tel. + 41 22 749 01 11
Fax + 41 22 749 09 47
E-mail copyright@iso.org
Web www.iso.org

Published in Switzerland

Foreword

ISO (the International Organization for Standardization) is a worldwide federation of national standards bodies (ISO member bodies). The work of preparing International Standards is normally carried out through ISO technical committees. Each member body interested in a subject for which a technical committee has been established has the right to be represented on that committee. International organizations, governmental and non-governmental, in liaison with ISO, also take part in the work. ISO collaborates closely with the International Electrotechnical Commission (IEC) on all matters of electrotechnical standardization.

International Standards are drafted in accordance with the rules given in the ISO/IEC Directives, Part 2.

The main task of technical committees is to prepare International Standards. Draft International Standards adopted by the technical committees are circulated to the member bodies for voting. Publication as an International Standard requires approval by at least 75 % of the member bodies casting a vote.

Attention is drawn to the possibility that some of the elements of this document may be the subject of patent rights. ISO shall not be held responsible for identifying any or all such patent rights.

ISO 16833 was prepared by Technical Committee ISO/TC 22, *Road vehicles*, Subcommittee SC 19, *Wheels*.

.....

Road vehicles — Wheels — Measurement of radial and lateral run-out

1 Scope

This International Standard defines criteria that characterize geometrical uniformity of wheels and describes principles of measurements of these criteria.

2 Normative references

The following referenced documents are indispensable for the application of this document. For dated references, only the edition cited applies. For undated references, the latest edition of the referenced document (including any amendments) applies.

ISO 3911, *Wheels and rims for pneumatic tyres — Vocabulary, designation and marking*

ISO 4000-2, *Passenger car tyres and rims — Part 2: Rims*

ISO 4209-2, *Truck and bus tyres and rims (metric series) — Part 2: Rims*

ISO 4223-1, *Definitions of some terms used in the tyre industry — Part 1: Pneumatic tyres*

ISO 5751-3, *Motorcycle tyres and rims (metric series) — Part 3: Range of approved rim contours*

ISO 13326, *Test methods for measuring tyre uniformity*

International vocabulary of basic and general terms in metrology (VIM), BIPM/IEC/IFCC/ISO/IUPAC/IUPAP/IUML, 1993

3 Terms and definitions

For the purposes of this document, the definitions given in ISO 4223-1, ISO 4000-2, ISO 4209-2, ISO 5751-3, ISO 3911, ISO 13326, the *International vocabulary of basic and general terms in metrology (VIM)* and the following apply.

3.1

radial run-out

RRO

variation over one revolution of the wheel of the distance X of the seat in question relative to the wheel rotation axis, in millimetres

See Figure 1.

3.2

lateral run-out

LRO

variation over one revolution of the wheel of the distance Y of the rim flange in question relative to a fixed reference plane perpendicular to the wheel rotation axis, in millimetres

See Figure 1.

NOTE The values of the radial and lateral run-out are algebraic (with a + or – Sign).

Dimensions in millimetres

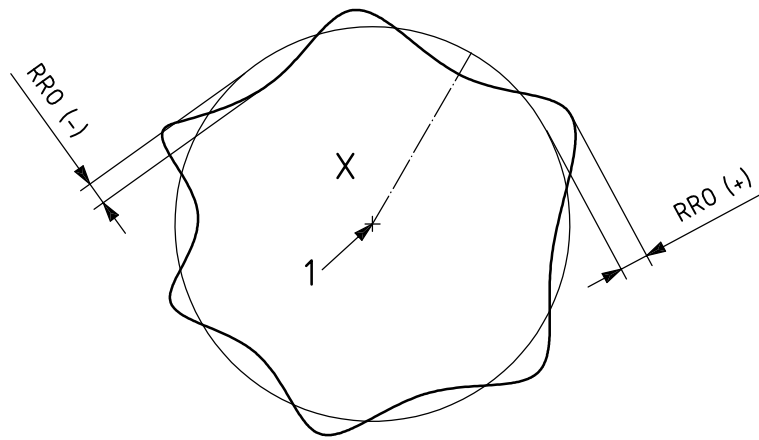

a) Radial run-out

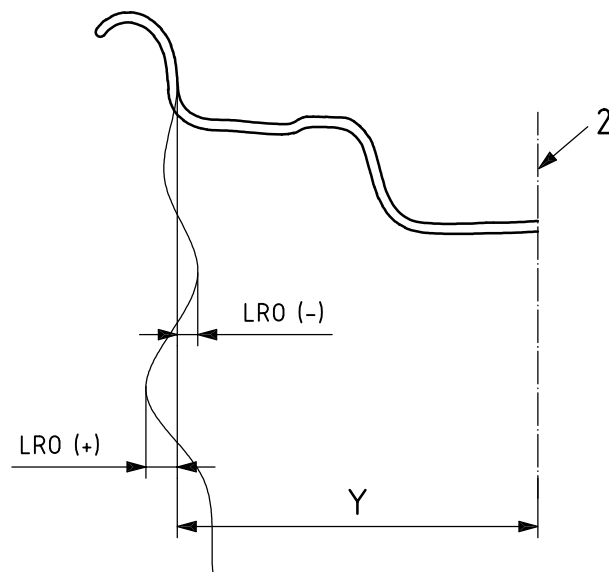

b) Lateral run-out

Key

- 1 wheel rotation axis
- 2 fixed reference plane perpendicular to the wheel rotation axis

RRO radial run-out
LRO lateral run-out

X distance of the seat relative to the wheel rotation axis
Y distance of the rim flange relative to a fixed reference plane perpendicular to the wheel rotation axis

Figure 1 — Radial and lateral run-out

3.3**uniformity**

constant value of any characteristics of the wheel in phase and magnitude both in static and in dynamic conditions around the circumference

NOTE Uniformity is concerned with axisymmetry of mass distribution, geometry and forces generated when the solid is in motion. The lack of uniformity in a wheel, when it is rotating around its axis, causes variation of forces, which may vary with the angular speed and are applied to the said axis.

3.4**peak-to-peak**

difference between the maximum and the minimum values of the measurement signal during one revolution

3.5**first harmonic**

peak-to-peak amplitude of the fundamental frequency component of the Fourier transform representing the variation

NOTE The frequency of first harmonic is equal to the frequency of rotation.

3.6**second (and higher order) harmonic**

peak-to-peak amplitude of the second (or higher order) frequency of the Fourier transform representing the variation

4 Principles of measurement**4.1 Datums**

Datums for each measurement shall be as follows.

4.1.1 Axis of rotation centre hole piloted wheel

For wheels which are centred by the centre hole on the vehicle hub, the axis of rotation is the centre hole axis defined at the wheel plane of the axis of the maximum inscribed cylinder.

4.1.2 Wheel attachment face

The wheel attachment face is the hub bearing surface plane P (see Figure 2) of the wheel plane (bearing plane of the wheel on the vehicle hub).

4.1.3 Axis of rotation of nut seat piloted wheel

For wheels which are centred by the fasteners' nut seats, the axis of rotation is the pitch circle axis defined by the implantation of the fasteners' nut seats (see Figure 2).

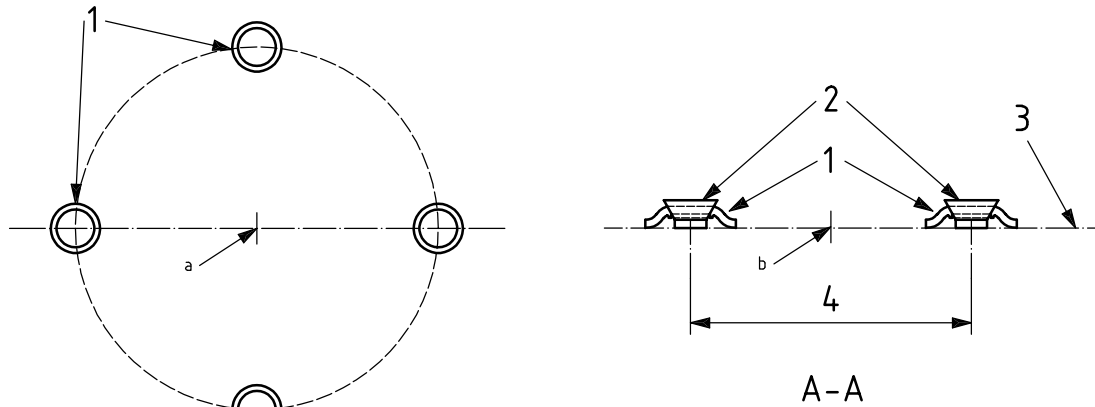

Key

- 1 bolt holes
- 2 fitting system
- 3 plane P
- 4 pitch circle diameter defined by the implantation of the fasteners' nut seats
- a Wheel rotation axis.
- b Rotation axis.

Figure 2 — Wheel attachment face and nut seat piloted wheel rotation axis

4.2 Taking measurements

For each of the rim seats, the measurements are defined by the contact points, over a wheel revolution, of a sphere of radius R while maintaining continuous contact on the seat and against the rim flange of the wheel.

Except where indicated otherwise on the drawing, the radius R of the sphere shall be $8 \pm 0,2$ mm.

- Contact points on the seat = measurement X.
- Contact points on the rim flange = measurement Y.

4.3 Measuring

In practice, the radial run-out or lateral run-out signal, over the wheel revolution, is made up of the measurement of a large number of points on each seat (128 points min.).

See principle of measurement diagram (Figure 3).

As the values are algebraic, the diagram sets out for each seat the directions giving the signification +/-.

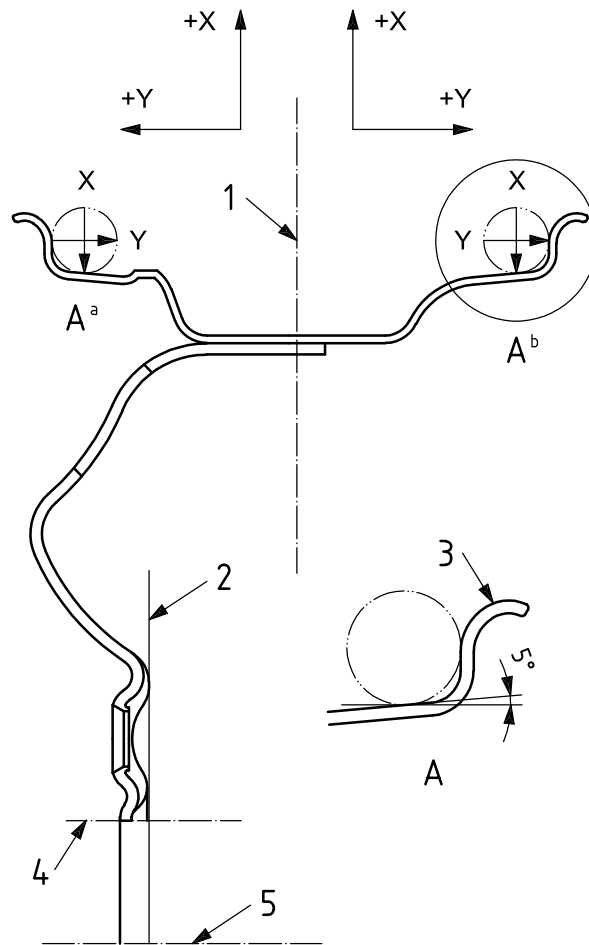

Key

- 1 rim axis
- 2 attachment face
- 3 flange wall
- 4 centre hole
- 5 wheel rotation axis
- X radial run-out
- Y lateral run-out
- a Outer.
- b Inner.

Figure 3 — Diagram of principle of measurement

5 Criteria specifying the radial run-out and the lateral run-out

5.1 Principle of harmonic decomposition

Considering X or Y as a function of the angular position θ of the measuring point, it can be expressed in the form of a Fourier series and values read over 360° developed as follows:

$$— X(\theta) = X_0 + X_1 \cos(\theta + \phi_1) + X_2 \cos(2\theta + \phi_2) + \dots + X_n \cos(n\theta + \phi_n)$$

$$— Y(\theta) = Y_0 + Y_1 \cos(\theta + \phi_1) + Y_2 \cos(2\theta + \phi_2) + \dots + Y_n \cos(n\theta + \phi_n)$$

See Figure 4 (example for X).

The value of each harmonic is given by the following expressions:

- $H_0 = X_0$ or Y_0
- $H_1 = X_1 \times 2$ or $Y_1 \times 2$
- $H_2 = X_2 \times 2$ or $Y_2 \times 2$
- $H_n = X_n \times 2$ or $Y_n \times 2$

See Figure 5.

5.2 Definition of average X and Y

Determine the average X and Y using the following formulas:

- X on Outer seat = X_{OUT} Y on Outer seat = Y_{OUT}
- X on Inner seat = X_{IN} Y on Inner seat = Y_{IN}
- Average $X = X_M$ Average $Y = Y_M$

$$X_M(\theta) = \frac{X_{OUT}(\theta) + X_{IN}(\theta)}{2} \qquad Y_M(\theta) = \frac{Y_{OUT}(\theta) + Y_{IN}(\theta)}{2}$$

See Figure 6 (example for average X).

5.3 Criteria specification of radial run-out and lateral run-out

Determine the following criteria based on the results obtained in 5.1 and 5.2.

5.3.1 Peak-to-peak

Peak-to-peak is the difference between the maximum value and the minimum value of the function $X_{IN}(\theta)$, $X_{OUT}(\theta)$ and $X_M(\theta)$ or $Y_{IN}(\theta)$, $Y_{OUT}(\theta)$ and $Y_M(\theta)$ in question.

5.3.2 Harmonic 1, 2, ... n

Harmonic 1, 2, ... n is the amplitude of the harmonic of rank 1, 2, ... n in the expression $X_{IN}(\theta)$, $X_{OUT}(\theta)$ and $X_M(\theta)$ or $Y_{IN}(\theta)$, $Y_{OUT}(\theta)$ and $Y_M(\theta)$ in question, according to the formulas in 5.1.

5.3.3 Low and high point of harmonic 1

Low point is the location on a wheel at which the minimum value of the first harmonic occurs (see Figure 4, point A).

High point is the location on a wheel at which the maximum value of the first harmonic occurs (see Figure 4, point B).

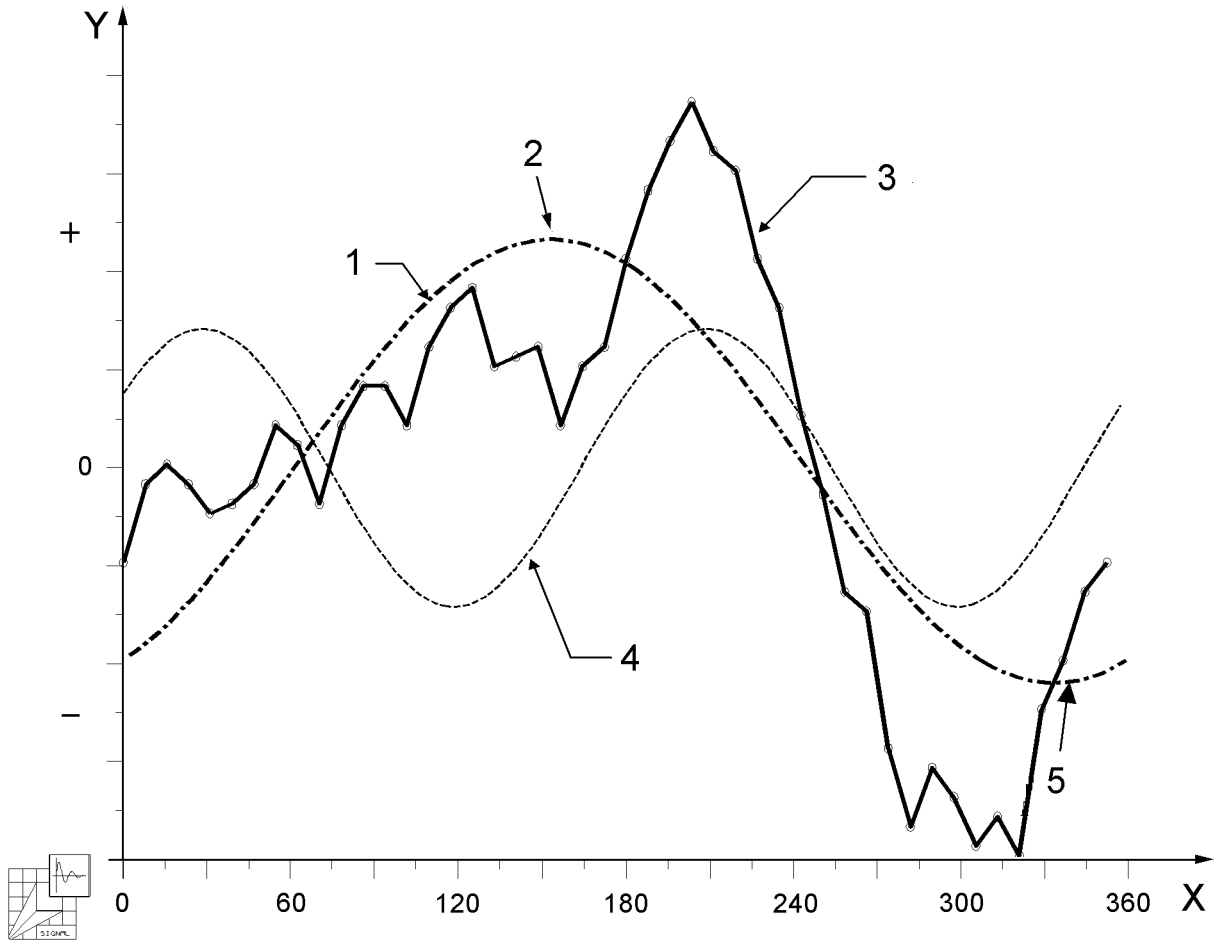

Key

- 1 first harmonic (calculated)
- 2 point B (high point)
- 3 initial signal (measured)
- 4 second harmonic (calculated)
- 5 point A (low point)
- X angle (°)
- Y X (mm)

Figure 4 — Graphic representation of the harmonic decomposition of X

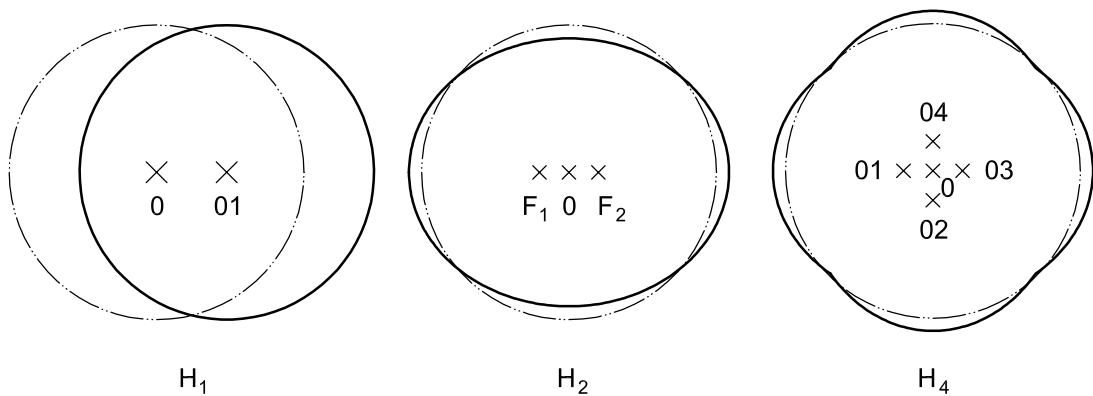
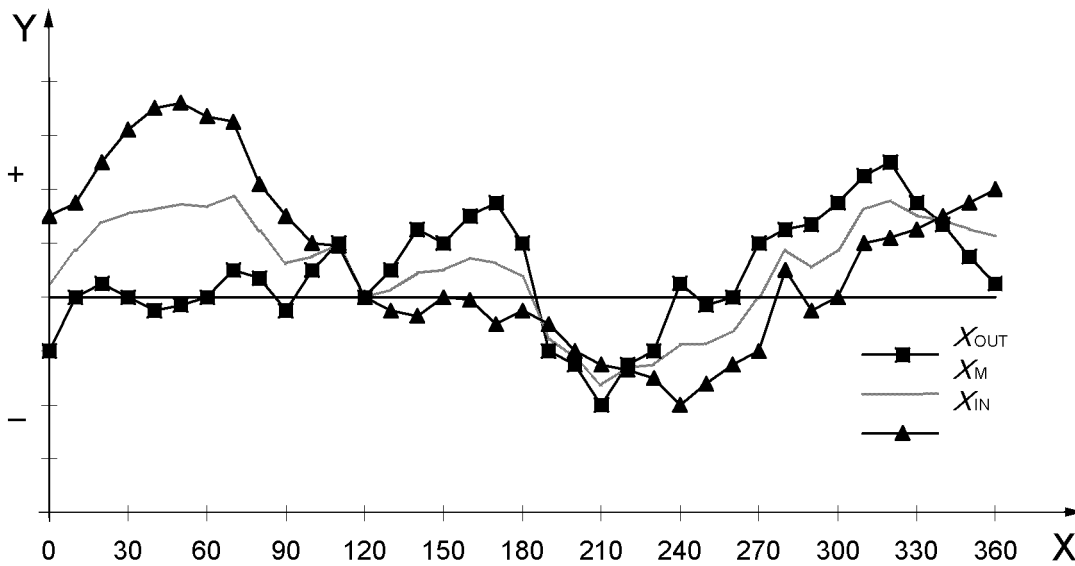

Figure 5 — Geometric representation of the harmonics



X angle (°)
 Y X (mm)

Figure 6 — Graphic representation of the average X_M

.....

ICS 43.040.50

Price based on 8 pages