

INTERNATIONAL STANDARD

ISO 16798

First edition
2004-07-01

Links of Grade 8 for use with slings

Mailles de classe 8 pour utilisation avec élingues



Reference number
ISO 16798:2004(E)

© ISO 2004

PDF disclaimer

This PDF file may contain embedded typefaces. In accordance with Adobe's licensing policy, this file may be printed or viewed but shall not be edited unless the typefaces which are embedded are licensed to and installed on the computer performing the editing. In downloading this file, parties accept therein the responsibility of not infringing Adobe's licensing policy. The ISO Central Secretariat accepts no liability in this area.

Adobe is a trademark of Adobe Systems Incorporated.

Details of the software products used to create this PDF file can be found in the General Info relative to the file; the PDF-creation parameters were optimized for printing. Every care has been taken to ensure that the file is suitable for use by ISO member bodies. In the unlikely event that a problem relating to it is found, please inform the Central Secretariat at the address given below.

© ISO 2004

All rights reserved. Unless otherwise specified, no part of this publication may be reproduced or utilized in any form or by any means, electronic or mechanical, including photocopying and microfilm, without permission in writing from either ISO at the address below or ISO's member body in the country of the requester.

ISO copyright office
Case postale 56 • CH-1211 Geneva 20
Tel. + 41 22 749 01 11
Fax + 41 22 749 09 47
E-mail copyright@iso.org
Web www.iso.org

Published in Switzerland

Contents

| | Page |
|--|-----------|
| 1 Scope | 1 |
| 2 Normative references | 1 |
| 3 Terms and definitions | 2 |
| 4 Safety requirements | 3 |
| 5 Verification of safety requirements | 7 |
| 6 Marking | 12 |
| 7 Manufacturer's certificate | 13 |
| 8 Instructions for use | 13 |
| Bibliography | 14 |

Foreword

ISO (the International Organization for Standardization) is a worldwide federation of national standards bodies (ISO member bodies). The work of preparing International Standards is normally carried out through ISO technical committees. Each member body interested in a subject for which a technical committee has been established has the right to be represented on that committee. International organizations, governmental and non-governmental, in liaison with ISO, also take part in the work. ISO collaborates closely with the International Electrotechnical Commission (IEC) on all matters of electrotechnical standardization.

International Standards are drafted in accordance with the rules given in the ISO/IEC Directives, Part 2.

The main task of technical committees is to prepare International Standards. Draft International Standards adopted by the technical committees are circulated to the member bodies for voting. Publication as an International Standard requires approval by at least 75 % of the member bodies casting a vote.

Attention is drawn to the possibility that some of the elements of this document may be the subject of patent rights. ISO shall not be held responsible for identifying any or all such patent rights.

ISO 16798 was prepared by Technical Committee ISO/TC 111, *Round steel link chains, chain slings, components and accessories*, Subcommittee SC 3, *Components and accessories*.

www.iso.org

Introduction

The links covered by this International Standard are normally supplied to be part of a sling, but could also be used for other applications. In such instances it is important that the link design be checked to ensure its fitness for the intended use.

Links of Grade 8 for use with slings

1 Scope

This International Standard specifies requirements for forged or welded steel master links, intermediate master links, master link assemblies and lower terminal links of Grade 8 up to 132 t WLL (working load limit), mainly for use in

- chain slings in conformance with ISO 4778 and ISO 7593,
- steel wire rope slings in conformance with ISO 7531, and
- textile slings in conformance with EN 1492-1 and EN 1492-2,

intended for lifting objects, materials or goods.

This International Standard is not applicable to hand-forged links.

2 Normative references

The following referenced documents are indispensable for the application of this document. For dated references, only the edition cited applies. For undated references, the latest edition of the referenced document (including any amendments) applies.

ISO 643, *Steels — Micrographic determination of the apparent grain size*

ISO 4778:1981, *Chain slings of welded construction — Grades M (4), S (6) and T (8)*

ISO 7500-1:—¹⁾, *Metallic materials — Verification of static uniaxial testing machines — Part 1: Tension/compression testing machines — Verification and calibration of the force-measuring system*

ISO 7531, *Wire rope slings for general purposes — Characteristics and specifications*

ISO 7593:1986, *Chain slings assembled by methods other than welding — Grade T(8)*

ISO/IEC Guide 62, *General requirements for bodies operating assessment and certification/registration of quality systems*

EN 818-6, *Short link chain for lifting purposes — Safety — Part 6: Chain slings — Specification for information for use and maintenance to be provided by the manufacturer*

EN 1492-1, *Textile slings — Safety — Part 1: Flat woven webbing slings made of man-made fibres, for general purpose use*

EN 1492-2, *Textile slings — Safety — Part 2: Roundslings made of man-made fibres, for general purpose use*

EN 10025, *Hot rolled products of non-alloy structural steels — Technical delivery conditions*

EN 10228-1, *Non-destructive testing of steel forgings — Part 1: Magnetic particle inspection*

EN 10228-2, *Non-destructive testing of steel forgings — Part 2: Penetrant testing*

1) To be published. (Revision of ISO 7500-1:1999)

3 Terms and definitions

For the purposes of this document, the following terms and definitions apply.

- 3.1**
working load limit
WLL
maximum mass a link is authorized to sustain in general lifting service
- 3.2**
manufacturing proof force
MPF
force applied to the link during the manufacturing proof test
- 3.3**
breaking force
BF
maximum force reached during the static tensile test of the link at the end of which the link fails to retain the load
- 3.4**
slings
assembly consisting of chain, wire rope or textile joined to upper and lower terminals, suitable for attaching loads to the hook of a crane or other lifting machine
- 3.5**
master link
link forming the upper terminal of a sling by means of which the sling is attached to the hook of a crane or other lifting machine
- 3.6**
intermediate master link
link used to connect one or two legs of a sling to a master link
- 3.7**
master link assembly
assembly consisting of a master link together with two intermediate master links
- 3.8**
lower terminal
link, hook or other device fitted at the end of a leg of a sling, remote from the master link or upper terminal
- 3.9**
traceability code
series of letters and/or numbers marked on a link that enable its manufacturing history, including the identity of the cast of steel used, to be traced.
- 3.10**
lot
specified number of links from which samples are selected for testing purposes and which have been manufactured from the same cast of steel and subjected to the same heat treatment
- 3.11**
integral joining device
means of connection that does not depend on welding and which is integrated with the link
- 3.12**
total ultimate elongation
total extension at the point of fracture of the link, expressed as a percentage of the internal length of the test sample

3.13**competent person**

designated person, suitably trained, qualified by knowledge and practical experience, and with the necessary instruction to enable the required test and examination to be carried out.

NOTE ISO 10015 gives guidance on training.

4 Safety requirements**4.1 Design**

Links shall be either

- a) parallel-sided links produced by forging — with or without integral joining devices — or by welding, or
- b) pear-shaped links with integral joining devices (i.e. links with unequal radii at either end) produced by forging.

Parts of integral joining devices, such as pins and their securing elements, shall be so designed and manufactured that, after assembly, no unintended displacement can occur.

The effects of wear, corrosion of securing elements or rough usage should be considered.

4.2 Dimensions

The internal dimensions of links covered by this International Standard shall be such as to ensure articulation so that the force imposed is transmitted in the intended direction.

The cross-section of links shall be in accordance with 4.5.

NOTE This requirement permits a varying shape and area of cross-section.

The internal length and internal width of parallel-sided master links shall be in accordance with Table 1.

The internal length of pear shaped master links shall be $53\sqrt{WLL}$ minimum (in millimetres) and the internal width at the widest point $27\sqrt{WLL}$ minimum (in millimetres), where the WLL is expressed in tonnes.

Table 1 — Internal length and width of parallel-sided master links

| WLL | Minimum internal length | Minimum internal width |
|-------------|-------------------------|------------------------|
| ≤ 25 t | $58\sqrt{WLL}$ | $31,5\sqrt{WLL}$ |
| > 25 t | $45\sqrt{WLL}$ | $25\sqrt{WLL}$ |

4.3 Materials and heat treatment**4.3.1 Quality of material****4.3.1.1 General**

Within the limitations given in 4.3.1.2 to 4.3.1.4, the manufacturer shall select the type of steel to be used so that the finished links, when suitably heat-treated, conform to the mechanical properties specified in this International Standard.

4.3.1.2 Type of steel

The steel shall be produced by an electric, or by an oxygen blown, process.

4.3.1.3 Deoxidation

The steel shall be fully killed as defined in EN 10025, stabilized against strain-age embrittlement, and have an austenitic grain size of 5 or finer when tested in accordance with ISO 643.

This shall be accomplished by ensuring that the steel contains sufficient aluminium (minimum 0,025 %) to permit the manufacture of links stabilized against strain age embrittlement during service.

4.3.1.4 Chemical composition

4.3.1.4.1 General

The steel shall contain alloying elements in sufficient quantities so that the finished link, when heat-treated in accordance with 4.3.2, not only conforms to the mechanical properties specified in this International Standard, but also possesses low temperature ductility adequate for working satisfactorily in the temperature range $-40\text{ }^{\circ}\text{C}$ to $400\text{ }^{\circ}\text{C}$.

The steel's sulfur and phosphorus content shall be restricted in accordance with Table 2.

Table 2 — Sulfur and phosphorus content

| Element | Maximum content (% by mass) determined by | |
|------------|---|----------------|
| | cast analysis | check analysis |
| Sulfur | 0,025 | 0,030 |
| Phosphorus | 0,025 | 0,030 |

4.3.1.4.2 Forged links

The steel shall contain at least two of the three alloying elements in accordance with Table 3.

Table 3 — Chemical composition — Alloying elements

| Element | Minimum content (% by mass) determined by cast analysis |
|------------|---|
| Nickel | 0,40 |
| Chromium | 0,40 |
| Molybdenum | 0,15 |

4.3.1.4.3 Welded links

The steel shall contain nickel and at least one of the other two alloying elements in accordance with Table 3.

4.3.2 Heat treatment

Each link shall be hardened from a temperature above the AC3 point and tempered before being subjected to the manufacturing proof force (MPF). The tempering temperature shall be a minimum of $400\text{ }^{\circ}\text{C}$.

The tempering conditions shall be at least as effective as a temperature of $400\text{ }^{\circ}\text{C}$ maintained for a period of 1 h.

A method of verification is that after the links have been reheated to, and maintained for 1 h at, 400 °C and then cooled to room temperature, they should conform in the finished condition to 4.5.2 and 4.5.3.

Surface hardening shall not be used.

4.4 Manufacturing methods and workmanship

4.4.1 Manufacture

4.4.1.1 Forged links

Each forged link shall be hot-forged in one piece. Excess metal from the forging operation shall be removed cleanly, leaving the surface free from sharp edges. After heat treatment, furnace scale shall be removed.

Edges of machined surfaces shall be rounded to ensure attainment of mechanical properties and to eliminate cutting edges.

4.4.1.2 Welded links

Each welded link shall be manufactured from steel of weldable quality.

Welds shall be produced using the resistance butt or flash butt process and shall be positioned in the centre of the leg of the link (see Figure 1).

The steel in the length affected by welding shall not be displaced at any point so as to undercut the contours of the link. The weld shall be smoothly finished all round.

The length affected by welding shall not extend by more than 0,6 of the material diameter to either side of the centre of the weld.

If the link has a flattened section, this shall be on the leg of the link opposite to the weld.

4.4.2 Surface finish

The finished condition of links shall include any surface finish.

NOTE Links are supplied in various surface finishes, e.g. de-scaled, electroplated or painted.

4.5 Mechanical properties

4.5.1 General

The mechanical properties of links shall be as specified in 4.5.2 to 4.5.5.

4.5.2 Manufacturing proof force (MPF)

The MPF shall be calculated by multiplying the appropriate WLL given in Table 4 by a factor of 2,5 and taking account of acceleration due to gravity (g).

Links, including load-bearing pins, if used, shall be able to withstand the MPF. Following removal of the force, the dimensions shall be within the tolerances specified on the link manufacturer's drawings.

4.5.3 Breaking force (BF) and total ultimate elongation

The BF shall be calculated by multiplying the appropriate WLL given in Table 4 by a factor of 4 and taking account of acceleration due to gravity (*g*). On completion of the static tensile test, the forged links shall show evidence of deformation and the welded links shall show a total ultimate elongation of not less than 20 %.

Links, including load-bearing pins if used, shall have a BF at least equal to that specified.

Table 4 — Working load limits

| Master links and lower terminal links Single-leg | Master links | | Intermediate master links |
|---|--------------|---------------------|---------------------------|
| | Two-leg | Three- and four-leg | |
| Working load limit (WLL) | | | |
| t | | | |
| 0,25 | 0,335 | 0,5 | 0,4 |
| 0,5 | 0,71 | 1,06 | 0,8 |
| 0,8 | 1,12 | 1,6 | 1,25 |
| 1,12 | 1,6 | 2,36 | 1,8 |
| 1,5 | 2,12 | 3,15 | 2,5 |
| 2 | 2,8 | 4,25 | 3,15 |
| 2,5 | 3,35 | 5 | 4 |
| 3,15 | 4,25 | 6,7 | 5 |
| 4 | 5,6 | 8 | 6,3 |
| 5,3 | 7,5 | 11,2 | 8,5 |
| 6 | 8 | 12,5 | 9,5 |
| 8 | 11,2 | 17 | 12,5 |
| 10 | 14 | 21,2 | 16 |
| 11,2 | 16 | 23,6 | 18 |
| 12,5 | 17 | 26,5 | 20 |
| 15 | 21,2 | 31,5 | 23,6 |
| 16 | 23,6 | 35,5 | 26,5 |
| 20 | 28 | 40 | 31,5 |
| 21,2 | 30 | 45 | 33,5 |
| 25 | 33,5 | 50 | 40 |
| 31,5 | 45 | 67 | 50 |
| 40 | 56 | 85 | 63 |
| 50 | 71 | 106 | 80 |
| 63 | 90 | 132 | 100 |

NOTE The working load limits for links are generally as given in EN 818-4:1996, Table 3, for multi-leg slings.

4.5.4 Fatigue resistance

Links, including load bearing pins if used, with a WLL of up to 32 t, shall withstand, without breaking, at least 20 000 cycles of application of the force range specified in 5.2.5.

4.5.5 Bend deflection

Test pieces taken from welded links shall withstand a minimum deflection of 0,8 times the link material diameter and shall be free from visible defects after bending.

5 Verification of safety requirements

5.1 Qualification of personnel

All testing and examination shall be carried out by a competent person.

5.2 Type tests and examination

5.2.1 General

In order to prove the design, material, heat treatment and method of manufacture, each size of link in the finished condition shall be type-tested to demonstrate that the links possess the mechanical properties specified in this International Standard.

Any change of design, specification of material, heat treatment, method of manufacture or of any dimension outside normal manufacturing tolerances that could lead to a modification of the mechanical properties defined in 4.5 shall require that the type tests specified in 5.2.3 to 5.2.6 be carried out on the modified links.

Links intended for use in a master link assembly shall be type-tested individually and not as an assembly.

The tests specified in 5.2.3 to 5.2.6 shall be carried out on three samples of each size of link of each design, material, heat treatment and method of manufacture.

Links designed for use with textile slings shall be tested (other than in fatigue) so that the force is applied through the appropriate textile element.

In the tests specified in 5.2.3 to 5.2.5, the force shall be applied to the link axially without shock, using a test fixture of not greater than 70 % of the internal width of the link.

The test machine used in the tests specified in 5.2.3 to 5.2.5 shall conform to ISO 7500-1:1999, Class 1.

5.2.2 Examination for design and dimensions

One sample of each design shall be visually examined for conformity with the requirements of 4.1 and 4.2.

5.2.3 Test for deformation

Three samples shall be tested and each shall sustain the MPF specified for the link in 4.5.2. Following the removal of the force, the dimensions shall be within the tolerances specified on the link manufacturer's drawings. In no case shall any dimension alter by more than 1,0 % of the initial dimension, after the MPF has been applied and removed.

5.2.4 Static tensile test and total ultimate elongation

Three samples shall be tested and each shall conform to the requirements specified in 4.5.3.

This test may be carried out on the same links subjected to the deformation test.

NOTE It is not necessary to test the link up to its actual BF for the specified mechanical properties to be demonstrated. It is sufficient that both the minimum BF and total ultimate elongation specified for welded links are reached.

5.2.5 Fatigue test

Three samples shall be tested and each shall be able to withstand at least 20 000 cycles of the force range without breaking.

The maximum force applied during each cycle shall be equivalent to 1,5 times the WLL given in Table 4. The minimum force in each cycle shall be positive and less than or equal to 3 kN. The frequency of force applications shall be not greater than 25 Hz.

5.2.6 Bend test

Three test piece samples shall be tested and each shall be bent in a shock free manner in the bend test equipment shown in Figure 2, and shall conform to the bend deflection requirements given in 4.5.5.

Test pieces taken from the links to be tested shall contain a central weld and shall have a length of five times the link diameter, as indicated in Figure 1.

The bend test equipment shall be as shown in Figure 2. The included angle of the V-block shall be 90° and the diameter of the mandrel shall be twice the link diameter.

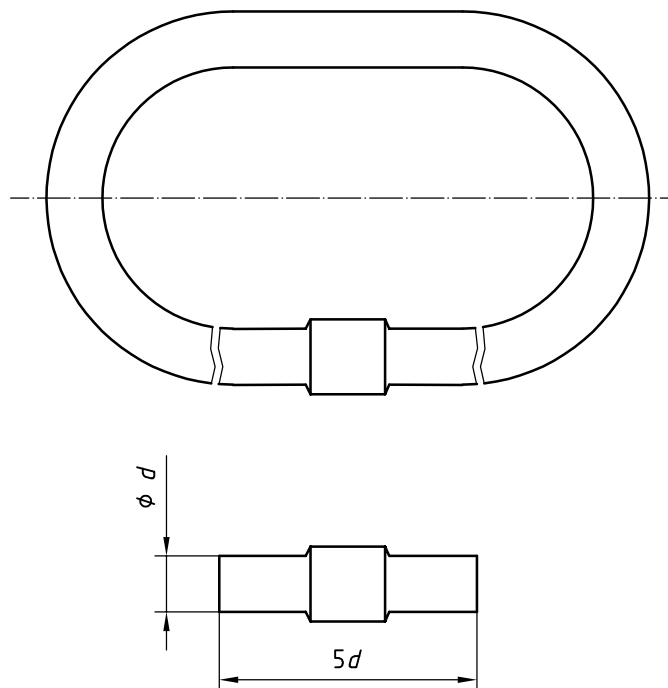

Figure 1 — Test pieces

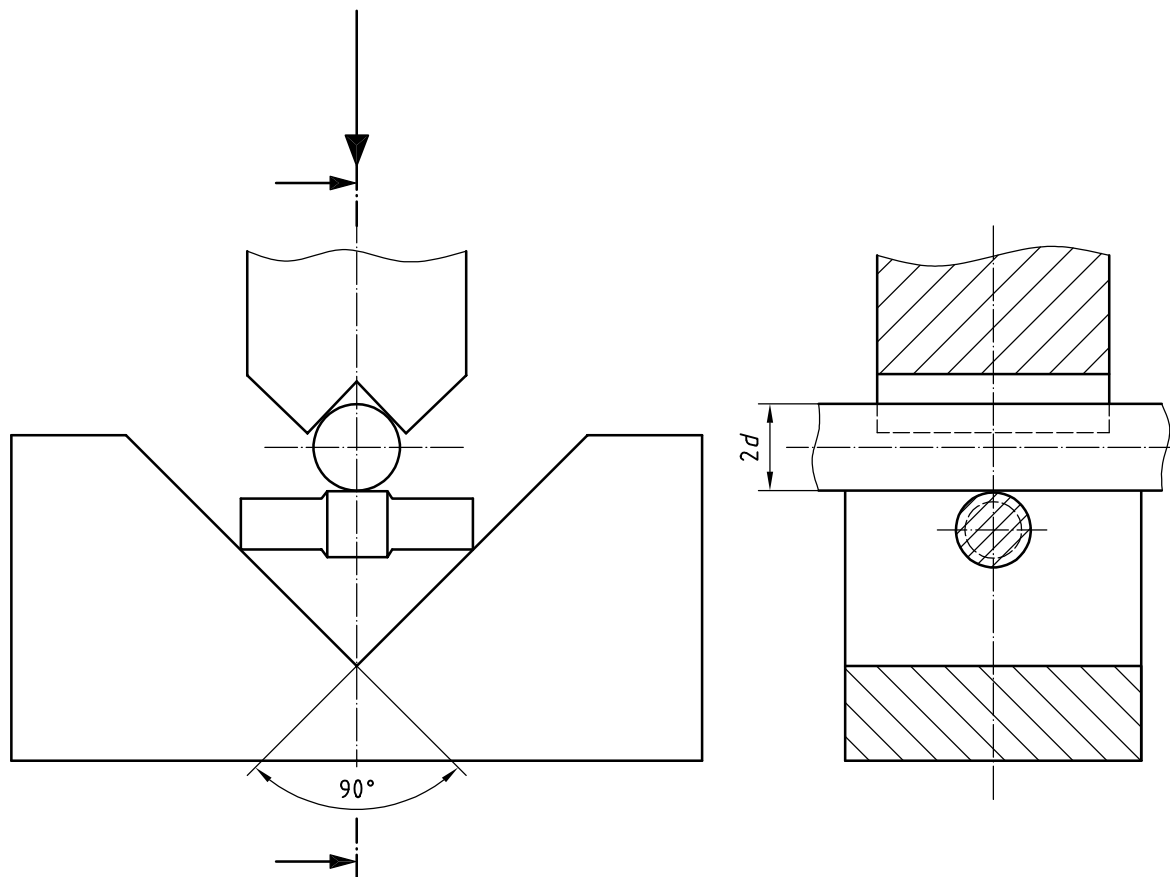

Figure 2 — Bend test equipment

5.2.7 Acceptance criteria for type tests and examination

5.2.7.1 Examination for design and dimensions

The sample shall meet the requirements in accordance with 5.2.2.

5.2.7.2 Test for deformation

If any of the three samples fails the test for deformation, the link of the size submitted for type testing shall be deemed not to conform with this International Standard.

5.2.7.3 Static tensile test and total ultimate elongation, fatigue test and bend test

If all three samples pass the static tensile test, fatigue test and bend test, the link of the size submitted for type testing shall be deemed to conform with this International Standard.

If one sample fails, two further samples shall be tested and both shall pass the test in order for the link of the size submitted for testing to be deemed to conform with this International Standard.

If two or three samples fail the test, the link of the size submitted for type testing shall be deemed as not conforming with this International Standard.

5.3 Manufacturing examination

All finished links shall be visually examined for conformity with the requirements of 4.4.1

5.4 Manufacturing tests

5.4.1 Manufacturing proof test and acceptance criteria

For the manufacturing proof test, the equipment used shall apply a force at least equal to the MPF specified.

After heat treatment and de-scaling, links shall sustain the appropriate MPF specified in 4.5.2. After removal of the force, there shall be no visible defect, and the dimensions shall be within the tolerances specified on the manufacturer's drawings.

Where finishing processes are used that involve risk of link embrittlement, e.g. acid cleaning or electroplating, the MPF shall be reapplied in the finished condition.

5.4.2 Non-destructive test and acceptance criteria (forged links)

The forged surfaces of links, excluding load bearing pins machined from drawn bar, shall, after heat treatment and de-scaling, be subjected to magnetic particle or dye penetrant examination in accordance with EN 10228-1 and EN 10228-2.

Indications greater than 2 mm in length shall not be permitted in areas of the link subjected to tensile stresses, in all foreseeable service conditions.

If grinding is required to remove such indications, then, after grinding, the link shall conform to the dimensions and tolerances specified by the manufacturer. A final examination shall show no indications greater than 2 mm in length.

Care should be taken to ensure that the direction and roughness of grinding do not create starting points for fatigue failure and cause excessive heating that may have a local effect on the heat treatment condition, or cause cracks.

Load-bearing pins machined from drawn bar shall be tested (e.g. by hardness testing or using magnetic sorting techniques) to demonstrate that they have been satisfactorily heat-treated. The pins shall be examined following heat treatment and shall be free from visible defects.

5.5 Manufacturing test regime — Forged links

5.5.1 General

The manufacturing test regime shall depend on whether the manufacturer has a quality system conforming to ISO 9001 and is certified by a certification body accredited according to ISO/IEC Guide 62.

If such a system is in place and operating, the manufacturer's test regime shall comply with 5.5.2. If no such system is in place or operating, the manufacturer's test regime shall comply with 5.5.3.

Alternative testing regimes are specified in 5.5.2. It is permissible for load bearing pins to be tested to a different regime to that of the rest of the link.

The maximum size of the lot shall be in accordance with Table 5.

Table 5 — Number of links in a lot

| Working load limit (WLL) | Maximum number in a lot |
|--------------------------|-------------------------|
| $WLL \leq 2,5$ | 1 000 |
| $2,5 < WLL \leq 10$ | 500 |
| $WLL > 10$ | 200 |

5.5.2 Manufacturing test regime and acceptance criteria when quality system conforming with ISO 9001 is in place and operating

If a quality system conforming to ISO 9001 is in place and operating, the manufacturer shall carry out either a) or b), as follows.

- a) Apply the MPF test to all links in the lot specified in Table 5 in accordance with 5.4.1 plus non-destructive testing of 3 % of the lot of links in accordance with 5.4.2.

If all of the 3 % sample of links pass the non-destructive test, then all the links in the lot which also pass the MPF test may be deemed to conform with this International Standard.

If any of the 3 % sample fail the non-destructive test, then all the links in the lot shall be subjected to both the non-destructive test and the MPF test. All links which pass both tests shall conform with this International Standard.

- b) Apply the non-destructive test to all links in the lot specified in Table 5 in accordance with 5.4.2 plus the MPF testing of 3 % of the lot of links in accordance with 5.4.1.

If all of the 3 % sample of links pass the MPF test, then all links in the lot which also pass the non-destructive test may be deemed to conform with this International Standard.

If any of the 3 % sample fail the MPF test, then all links in the lot shall be subjected to both the non-destructive test and the MPF test. All links which pass both tests shall conform with this International Standard.

5.5.3 Manufacturing test regime and acceptance criteria when quality system conforming to ISO 9001 is not in place or not operating

If a quality system conforming to ISO 9001 is not in place or not operating, the manufacturer shall carry out a manufacturing proof test in accordance with 5.4.1 and a non-destructive test in accordance with 5.4.2 on every link, including load bearing pins. Any link failing the manufacturing proof test or the non-destructive test shall be deemed as not conforming with this International Standard.

All links that pass both the manufacturing proof test and the non-destructive test shall conform with this International Standard. In addition, the manufacturer shall subject one sample per lot to the static tensile test in accordance with 5.2.1 and 5.2.4. If the sample meets the appropriate requirements, then the lot may be deemed to conform with this International Standard.

If the sample fails to meet the requirements, then two further samples shall be taken from the same lot. Both of these samples shall be subjected to the static tensile test. If one or both of these samples fail to meet the appropriate requirements, the entire lot shall be deemed as not conforming with this International Standard.

5.6 Manufacturing test regime — Welded links

5.6.1 General

The manufacturing test regime shall depend on whether the manufacturer has a quality system that conforms with ISO 9001 and is certified by a certification body accredited to ISO/IEC Guide 62.

If such a system is in place and operating, the manufacturer's test regime shall comply with 5.6.2. If no such system is in place or operating, the manufacturer's test regime shall conform to 5.6.3.

The maximum size of the lot shall be in accordance with Table 5.

5.6.2 Manufacturing test regime and acceptance criteria when quality system conforming to ISO 9001 is in place and operating

If a quality system conforming to ISO 9001 is in place and operating, the manufacturer shall apply the manufacturing proof test to all links supplied in accordance with 5.4.1.

Any link failing the manufacturing proof test shall be deemed as not conforming with this International Standard.

5.6.3 Manufacturing test regime and acceptance criteria when quality system conforming to ISO 9001 is not in place or not operating

If a quality system conforming to ISO 9001 is not in place or not operating, the manufacturer shall carry out manufacturing proof test in accordance with 5.4.1 on all links supplied. Any link failing the manufacturing proof test shall be deemed not to conform with this International Standard.

In addition the manufacturer shall subject one sample per lot to the static tensile test in accordance with 5.2.4. If the sample meets the appropriate requirements, then the lot may be deemed to conform with this International Standard.

If the sample fails to meet the requirements then two further samples shall be taken from the same lot. Both of these samples shall be subjected to the static tensile test. If one or both of the samples fail to meet the appropriate requirements, the entire lot shall be deemed as not conforming with this International Standard.

In addition, the manufacturer shall subject one sample per lot to the bend test in accordance with 5.2.6. If the sample meets the appropriate requirements, then the lot may be deemed to conform with this International Standard.

If the sample fails to meet the requirements, then two further samples shall be taken from the same lot. Both of these samples shall be subjected to the bend test.

If one or both of these samples fail to meet the appropriate requirements, the entire lot shall be deemed not to conform with this International Standard.

6 Marking

6.1 Links

Each link, master link or master link assembly shall be legibly and indelibly marked in a place where the marking will not be removed by use and in a manner that will not impair the mechanical properties. The marking shall include at least the following information:

- a) manufacturer's product code;
- b) grade number, i.e. 8;
- c) manufacturer's name, symbol or mark;
- d) traceability code.

Care should be taken to ensure that the marking cannot be mistaken for the WLL of the link.

The manufacturer's product code should provide the WLL and applications for which the link is suitable.

6.2 Load bearing pins

Each removable load bearing pin of 13 mm diameter and above, shall be legibly and indelibly marked with the relevant grade number and the manufacturer's symbol in a manner that will not impair the mechanical properties of the pin.

7 Manufacturer's certificate

After all the testing in accordance with Clause 5 has been carried out with satisfactory results, the manufacturer shall issue a certificate for links of the same nominal dimensions, size, material, heat treatment and method of manufacture as the links tested.

The certificate shall include at least the following information:

- a) name and address of the manufacturer or authorized representative, including the date of issue of the certificate and authentication;
- b) number of this International Standard, i.e. ISO 16798;
- c) manufacturer's product code;
- d) quantity and description of the link or master link assembly;
- e) grade number, i.e. 8;
- f) WLL, in tonnes;
- g) MPF, in kilonewtons;
- h) confirmation that the specified minimum BF was met or exceeded;
- i) identification of the quality system used, for example, ISO 9001, when in place and operating.

The manufacturer shall keep a record for at least 10 years after the last certificate has been issued of the material specification, heat treatment, dimensions, test results, quality system in use and all relevant data concerning the links that have satisfied the type tests, including records of sampling. This record shall also include the manufacturing specifications that shall apply to subsequent production.

8 Instructions for use

Instructions for use shall accompany the links, master links or master link assemblies and shall conform to the relevant clauses of EN 818-6, including a description of the applications (such as WLL and number of legs). Advice shall be given on how to assemble and disassemble forged links with an integral joining device and how to ensure the correct fit of the pin.

Bibliography

- [1] ISO 6507-1:1997, *Metallic materials — Vickers hardness test — Part 1: Test method*
- [2] ISO 9001:2000, *Quality management systems — Requirements*
- [3] ISO 10015:1999, *Quality management — Guidelines for training*
- [4] EN 818-4:1996, *Short link chain for lifting purposes — Safety — Part 6: Chain slings — Grade 8*

.....

ICS 53.020.30

Price based on 14 pages